



**MANUAL ON
SEWERAGE AND SEWAGE
TREATMENT
(SECOND EDITION)**

Prepared by:
THE EXPERT COMMITTEE

Constituted by:
THE GOVERNMENT OF INDIA

**CENTRAL PUBLIC HEALTH
AND ENVIRONMENTAL ENGINEERING ORGANISATION**

**MINISTRY OF URBAN DEVELOPMENT
NEW DELHI
DECEMBER, 1993**

PPHEE 0-8
10,000—1994 (DSK—IV)

Price : (Inland) Rs. 210.00 (Foreign) £ 24.49 or \$ 75 60 Cents.

PRINTED BY THE MANAGER, GOVT. OF INDIA PRESS, NASIK-422 006
AND PUBLISHED BY THE CONTROLLER OF PUBLICATIONS, DELHI-110 054
1995



मंत्री
शहरी विकास
भारत सरकार
MINISTER OF
URBAN DEVELOPMENT
GOVT. OF INDIA
New Delhi, December 1993

FOREWORD

Safe water supply and hygienic sanitation facilities are the two basic essential amenities the community needs on a top priority for healthy living. While provision of safe drinking water takes precedence in the order of provision of basic amenities to community, the importance of hygienic sanitation facilities through low cost on-site sanitation, conventional sewerage and sewage treatment can no longer be allowed to lag behind, as about 80% of water used by the community comes out of houses in the form of waste water which unless properly collected, conveyed, treated and safely disposed of may eventually pollute our precious water resources and cause environmental degradation.

As of now about 45% of urban population has been provided with reasonable hygienic sanitation facilities in our country and as such there is still much to accomplish so as to reach 100% coverage. While it is necessary to adopt conventional sewerage and treatment methods in our metro and mega cities, it is economical to go in for low cost option wherever feasible particularly in small and medium towns. Yet another important area which needs the urgent attention of our Public Health and Environmental Engineers is possibility of re-use and recycling of waste water after necessary treatment for various beneficial uses so as to reduce the ever increasing demand for fresh water.

It is hoped the revised Manual on Sewerage and Sewage Treatment brought out by the Central Public Health and Environmental Engineering Organisation of this Ministry will meet the professional needs of the practising Engineers dealing with sanitation sector in the country for achieving the goal of "sanitation for all" within a reasonable time frame.

P. Kaul
(SHEILA KAUL)

P R E F A C E

The first Manual on Sewerage and Sewage Treatment was published by the erstwhile Ministry of Works & Housing (presently Ministry of Urban Development) on the basis of recommendations of an Expert committee in 1977. The said Manual has been in use widely by field Engineers who are engaged in the field of sewerage and sewage treatment. However, over a period of time there has been an advancement in the technology and as such the need for revising and updating the said manual has been keenly felt for quite some time. The conference on Mid-Decade Review of Water Decade Programme held in October, 1985 recommended the setting up of Expert Committee for undertaking this task. Accordingly the Ministry of Urban Development, Govt. of India constituted an Expert Committee in December, 1985 with the following composition:-

- | | | |
|----|---|----------|
| 1. | Shri. V.Venugopalan
Adviser(PHEE)
Central Public Health &
Environmental Engineering
Organisation,
Ministry of Urban Development
Nirman Bhavan, New Delhi. | Chairman |
| 2. | Shri.K.R. Bulusu,
Acting Director,
National Environmental Engg.
Research Institute,
Nehru Marg, Nagpur-20. | Member |
| 3. | Director
All India Institute of Hygiene
& Public Health or his
representative,
Chittaranjan Avenue, Calcutta. | Member |
| 4. | Chief Engineer (Urban),
Maharashtra Water Supply &
Sewerage Board,
C.I.D.C.O., Bhavan,
South Wing, 2nd Floor,
New Bombay-14. | Member |
| 5. | Chief Engineer (Urban Services)
Tamil Nadu Water Supply &
Drainage Board, TWAD Building,
Chepauk, Madras. | Member |
| 6. | Director (Engg),
Madras Metropolitan Water
Supply & Sewerage Board,
Pumping Station Road,
Chindaripet, Madras. | Member |
| 7. | Chief Engineer,
Local Self Govt. and
Urban Development Deptt.,
Govt. of West Bengal,
No.1, Garstin Place,
Calcutta-1 | Member |

- | | | |
|-----|---|------------------|
| 8. | Dr. R. Pitchai,
Prof. & Director,
Centre for Environmental Studies,
Anna University, Madras. | Member |
| 9. | Shri M.R. Parthasarathy,
Dy. Adviser (PHE)
C.P.H.E.E.O.,
Ministry of Urban Development,
Nirman Bhavan, New Delhi. | Member |
| 10. | Chief Engineer,
Gujarat Water Supply & Sewerage
Board,
Near Mayur Hotel, Sector-16,
Gandhinagar-382016. | Member |
| 11. | Director or his representative
Central Ganga Authority,
Ministry of Environment &
Forests,
New Delhi. | Member |
| 12. | Chairman or his representative
Central Board for Prevention
and Control of Water Pollution,
Nehru Place,
New Delhi. | Member |
| 13. | Dr. H.C. Arora,
Deputy Adviser (Trg.)
C.P.H.E.E.O.,
Ministry of Urban Development,
Nirman Bhavan,
New Delhi. | Member-Secretary |

Since some of the members of the Expert Committee including the then Chairman had retired, it became necessary to reconstitute the said Expert Committee in March, 1990 with the following composition:-

- | | | |
|----|--|---|
| 1. | Adviser (PHEE),
Ministry of Urban Development
C.P.H.E.E.O. New Delhi. | Chairman
(Sri.P.S.Rajvanshy, had taken over the charge of the
Post of Adviser since November, 1990) |
| 2. | Shri. S.S. Patwardhan
Member Secretary,
Maharashtra Water Supply & Sewerage
Board, Bombay. | Member |
| 3. | Shri. S.K. Neogi,
Chief Engineer,
Govt. of West Bengal,
Municipal Engg. Deptt.
Calcutta. | Member |

4.	Shri. J.D. Seth, Chief Engineer, Gujarat Water Supply and Sewerage Board, Gandhinagar, Gujarat.	Member
5.	Shri. L.Panneerselvam, Deputy Director, Ganga Project Directorate, New Delhi.	Member
6.	Dr. K.R.Ranganathan, Member Secretary, Central Pollution Control Board, New Delhi.	Member
7.	Shri. A.K.Awasthi, Deputy Director, Indian Standards Institute, New Delhi.	Member
8.	Dr.S.R. Shukla, Dy. Adviser (PHE), C.P.H.E.E.O., Ministry of Urban Development New Delhi.	Member
9.	Shri. R.Sethuraman, Asstt. Adviser(PHE), Ministry of Urban Development C.P.H.E.E.O.	Member
10.	Shri. V.B. Rama Prasad, Dy. Adviser (PHE) Ministry of Urban Development, C.P.H.E.E.O.	Member Secretary
11.	Dr. S.D. Badrinath Asst. Director, NEERI, Nagpur.	Member
12.	Dr.-D. M. Mohan, Director (Project), HMWSS Board, Hyderabad.	Member
13.	Dr. I.C.Agarwal, Professor of Environmental Engg. Motilal Engineering College, Allahabad.	Member
14.	Dr. R.Guruswamy, Professor, Anna University, Madras.	Member

- | | | |
|-----|---|--------|
| 15. | Shri. S.Deivamani,
Rtd. Engineering Director,
Madras Metro Water Supply &
Sewerage Board, Madras. | Member |
| 16. | Shri. S.Shankarappa,
Chief Engineer,
Municipal Corporation of
Greater Bombay, Bombay. | Member |
| 17. | Shri. M.R.Parthasarathy,
Rtd. Dy.Adviser (PHE),
Ministry of Urban Development
C.P.H.E.E.O., Bangalore. | Member |
| 18. | Shri D'Cruz,
Rtd. Engineer-in-Chief,
Delhi Water Supply & Sewerage
Disposal Undertaking, Delhi. | Member |
| 19. | Shri. S.D.Mundra,
Director,
Geo-Millers & Co. Pvt. Ltd.,
New Delhi. | Member |
| 20. | Shri. S.J. Arceivala,
Managing Director,
M/s. Associate Industrial
Consultants (India) Pvt. Ltd.,
Bombay. | Member |
| 21. | Dr. R.H. Siddiqi,
Professor,
Aligarh Muslim University,
Aligarh. | Member |
| 22. | Shri. S.L.Abhyankar,
Hony. Technical Adviser,
Indian Pump & Pump Mfg. Assocn.,
Bombay. | Member |

The originally constituted Expert committee met 5 times and the reconstituted Committee held 16 meetings in all, to discuss and finalise the draft Manual. Later, in October, 1992 the Ministry had constituted a three members Editorial Committee consisting of the following members for editing and finalising the said draft document:-

1. J.D'Cruz,
Consultant,
WAPCOS.
2. Dr. I.C.Agarwal,
Head of the Dptt. of Civil Engineering,
MNREC, Allahabad.
3. Dr. D.M. Mohan,
Director (Projects)
HMWSS Board, Hyderabad (A.P.).

The said Editorial committee met 3 times to complete the task assigned to it. In all there, are 26 chapters in the Manual covering various important aspects such as Planning, Legal, Financial and Administrative aspects, Design and Construction of Sewers, Sewage Treatment Plants, Sludge Treatment and Disposal, Tertiary Treatment of Sewage for Reuse, Effluent Disposal and its Utilisation, On-Site Sanitation, Corrosion Prevention and its control, Operation and Maintenance of Sewerage System as well as Treatment Plants etc. It is pertinent to mention that several modifications have been suggested in various chapters mentioned above. For instance, since conventional sewerage is very expensive it has to be confined to Class-I cities and capitals of States/UTs. Even in such cities, sewerage has to be confined to core areas only and the fringe areas have to be provided with less expensive on-site sanitation systems. Similarly, taking into account the hydraulics and other relevant factors, the design of sewers has been modified to make it economical. In so far as treatment of sewage is concerned, Anaerobic method such as USAB technology has been introduced since it is less energy intensive and economical in operation and maintenance. Similarly, duckweed ponds have been suggested for treating sewage in an economical way with impressive cash returns. Adequate emphasis has been given to reuse and recycling of sewage effluent after tertiary treatment, keeping in view the ever increasing demand for fresh water for various beneficial uses. Operation and Maintenance of Sewerage Systems and Sewage Treatment Plants is often neglected due to inadequate funds and lack of trained technical manpower. Therefore, these aspects have been given due emphasis and discussed in detail. Later, in November, 1992 the draft Manual was circulated to various State Public Health Engineering Deptts. and Water Supply and Sewerage Boards with a view to have their valuable suggestions on the same before its finalisation and printing. Finally the contents of the Manual were thoroughly discussed in greater detail, topic by topic at a special conference of Chief Engineers incharge of Urban Water Supply and Sanitation Sector held at Thiruvananthapuram (Kerala) on 24th and 25th September, 1993 organised by the Ministry of Urban Development and Kerala Water Authority.

The said Conference was well attended and valuable suggestions that emerged during the discussions have been incorporated to the extent possible to make this Manual useful from the practising Engineer's point of view. There are no two opinions that the said Manual will be a boon to the field Engineers in the country.

The Expert Committee thanks the Ministry of Urban Development, Govt. of India for providing all facilities. The initiative taken and sincere efforts made by Shri.V.Venugopalan, the then Adviser(PHEE) in getting the original Expert Committee constituted is gratefully acknowledged. The Committee expresses its appreciation to Shri.V.B. Rama Prasad, Dy.Adviser (PHE) and Member-Secretary for his untiring efforts in making possible the completion of the manual in its finest form despite his arduous normal duties. Special mention is made of the services of Shri.R.Sethuraman, Dy.Adviser(Trg.) and Shri.M.Sankaranarayanan, Asst. Adviser(PHE) who unstintingly devoted their time in all phases of this work. The valuable contribution of Dr.S.R. Shulka, Dy.Adviser (PHE), Shri.B.B.Uppal, Asst. Adviser (PHE) and Shri.Sukanta Kar, Scientific Officer in CPHEEO are gratefully acknowledged. The committee thanks Dr.D.M. Mohan, Presently Director (Projects), Hyderabad Metropolitan Water Supply and Sewerage Board for getting the final draft computerised. Thanks are also due to the Govt. of Kerala and Kerala Water Authority for hosting the aforesaid conference.

Last but not the least, the committee desires to record their deep appreciation of the services rendered by different Officers and staff members of the PHE and Accounts Section of the Ministry and the Secretariat of CPHEEO.

P.S.RAJVANSHY
ADVISER (PHEE)
C.P.H.E.E.O.



CONTENTS

1	PLANNING	1
1.1	OBJECTIVE	1
1.2	NEED FOR PLANNING	1
1.3	BASIC DESIGN CONSIDERATIONS	1
1.3.1	Engineering Considerations	1
1.3.2	Environmental Considerations	2
1.3.3	Process Considerations	3
1.3.4	Cost Considerations	5
1.4	DESIGN PERIOD	5
1.5	POPULATION FORECAST	5
1.5.1	General Considerations	5
1.5.2	Final Forecast	8
1.6	ESTIMATION OF WASTE WATER FLOW	8
1.6.1	Sources of Waste Water	8
1.6.2	Per Capita Waste water Flow	8
1.7	SEWAGE CHARACTERISTICS	8
1.7.1	Effect of Industrial Waste	9
1.8	SURVEY AND INVESTIGATION	9
1.8.1	Basic Information	9
1.8.1.1	Physical Aspects	9
1.8.1.2	Developmental Aspects	9
1.8.1.3	Fiscal Aspects	10
1.8.1.4	Other Aspects	10
1.8.2	Project Surveys	11
1.8.2.1	Preliminary Project Surveys	11
1.8.2.2	Detailed Project Surveys	11
1.8.2.3	Construction Surveys	11

1.9	PROJECT REPORT	12
1.9.1	General	12
1.9.1.1	Project Reports	12
1.9.2	Identification Report	12
1.9.3	Prefeasibility Report	14
1.9.3.1	Executive Summary	14
1.9.3.2	Introduction	14
1.9.3.3	Project Area and The Need for The Project	15
1.9.3.4	Long Term Plan for Wastewater Disposal	17
1.9.3.5	Proposed Waste Water Project	18
1.9.3.6	Conclusions and Recommendations	20
1.9.4	Feasibility Report	21
1.9.4.1	Contents	22
1.9.4.2	Background	22
1.9.4.3	The Proposed Project	22
1.9.4.4	Institutional and Financial Aspects	25
1.9.4.5	Conclusions and Recommendations	25
2	MANAGEMENT, ADMINISTRATION, LEGAL AND FINANCIAL ASPECTS	27
2.1	MANAGEMENT	27
2.1.1	Government of India (G.O.) Level	27
2.1.2	State Government Level	27
2.1.3	Local Body Level	27
2.2	COMMON ASPECTS OF MANAGEMENT	27
2.2.1	General Administration	28
2.2.1.1	Supervisory Staff	28
2.2.1.2	Operating Staff	29
2.2.2	Personnel Administration	30
2.2.3	Inventory Control	30

2.2.4	Financial Control	31
2.2.4.1	Accounting	31
2.2.4.2	Budgeting	31
2.2.5	Public Relations	31
2.3	OTHER ASPECTS OF MANAGEMENT	32
2.3.1	Inservice Training	32
2.3.2	Long Term Planning	33
2.4	LEGAL ASPECTS	33
2.4.1	Municipal Bylaws	33
2.4.2	Prevention of Pollution	34
2.5	FINANCIAL ASPECTS	34
2.5.1	General	34
2.5.2	Scope	35
2.5.3	Sources for Raising Capital	35
2.5.4	Financial Appraisal	35
2.5.5	Statutory Water and Sanitation Boards	36
3	DESIGN OF SEWERS	37
3.1	INTRODUCTION	37
3.2	ESTIMATION OF SANITARY SEWAGE	37
3.2.1	Design Period	37
3.2.2	Population Forecast	38
3.2.3	Tributary Area	39
3.2.4	Percapita Sewage Flow	39
3.2.5	Flow Assumptions	39
3.2.6	Storm Runoff	40
3.2.7	Ground Water Infiltration	40

3.3	ESTIMATION OF STORM RUNOFF	40
3.3.1	Rational Method	41
3.3.1.1	Runoff - Rainfall Intensity Relationship	41
3.3.1.2	Storm Frequency	41
3.3.1.3	Intensity of Precipitation	41
3.3.1.4	Time of Concentration	43
3.3.1.5	Coefficient of Runoff	43
3.4	HYDRAULICS OF SEWERS	45
3.4.1	Type of Flow	45
3.4.2	Flow - Friction Formulae	46
3.4.2.1	Mannings Formula	46
3.4.2.2	Darcy Weisbach Formula	46
3.4.2.3	Hazen-Williams Formula	48
3.4.2.4	Friction Coefficients	48
3.4.2.5	Modified Hazen-Williams Formula	49
3.4.2.6	Depth of Flow	49
3.4.2.7	Formula for Self Cleansing Velocity	52
3.4.3	Velocities	52
3.4.3.1	Velocity At Minimum Flow	53
3.4.3.2	Erosion and Maximum Velocity	53
3.4.4	Sewer Transitions	53
3.4.4.1	Non Uniform Flow	53
3.4.4.2	Specific Energy	54
3.4.4.3	Hydraulic Jump	54
3.4.4.4	Back Water Curves	55
3.4.4.5	Sewer Transitions	56
3.4.4.6	Bends	56
3.4.4.7	Junction	57
3.4.4.8	Vertical Drops and Other Energy Dissipators	57

3.4.5	Inverted Syphon	57
3.4.5.1	Hydraulic Calculations	61
3.4.5.2	Velocity	61
3.4.5.3	Size and Arrangement of Pipes	61
3.4.5.4	Inlet and Outlet Chambers	61
3.4.5.5	General Requirements	61
3.4.6	Relief Sewers	63
3.4.7	Force Mains	63
3.4.8	Sulphide Generation	63
3.5	DESIGN OF SEWER SYSTEMS	64
3.5.1	Introduction	64
3.5.2	Available Head	64
3.5.3	Layout of Systems	64
3.5.3.1	Plans	65
3.5.4	Design Approach	66
3.5.4.1	Design Steps	66
3.6	SMALL BORE SEWER SYSTEMS	66
3.6.1	System Description	66
3.6.2	Components of System	70
3.6.3	Suitability of the System	70
3.6.4	Design Criteria	70
3.6.5	Appurtenances	70
3.6.6	Disposal of Effluent	71
3.6.7	Limitations	71
3.7	SHALLOW SEWERS	71
3.7.1	System Description	71
3.7.2	Components of the System	71
3.7.3	Applicability	72
3.7.4	Limitations	72

3.8	NON CIRCULAR SEWERS	72
4	SEWER APPURTENANCES	74
4.1	INTRODUCTION	74
4.2	MANHOLES	74
4.2.1	Ordinary Manholes	74
4.2.1.1	Spacing	74
4.2.1.2	Constructional Details	74
4.2.1.3	Covers and Frames	78
4.2.2	Types of Manholes	78
4.2.2.1	Straight - Through Manholes	78
4.2.2.2	Junction Manholes	79
4.2.2.3	Side Entrance Man Holes	79
4.2.2.4	Drop Manholes	79
4.2.2.5	Scraper (service) Type Manhole	81
4.2.2.6	Flushing Manholes	81
4.3	INVERTED SIPHONS	82
4.4	HOUSE SEWER CONNECTIONS	82
4.5	STORM WATER INLETS	83
4.5.1	Curb Inlets	83
4.5.2	Gutter Inlets	83
4.5.3	Combination Inlets	83
4.6	CATCH BASINS	83
4.7	REGULATOR OR OVERFLOW DEVICE	84
4.7.1	Side Flow Weir	84
4.7.2	Leaping Weir	84
4.7.3	Float Actuated Gates and Valves	84
4.8	FLAP GATES AND FLOOD GATES	84
4.9	MEASURING DEVICES	85
4.10	SEWER VENTILATORS	85

5	MATERIALS FOR SEWER CONSTRUCTION	87
5.1	INTRODUCTION	87
5.2	TYPES OF MATERIAL	87
5.2.1	Brick	87
5.2.2	Concrete	87
5.2.2.1	Precast Concrete	88
5.2.2.2	Cast-In-Situ Reinforced Concrete	88
5.2.3	Stoneware or Vitrified Clay	88
5.2.4	Asbestos Cement	88
5.2.5	Iron and Steel	89
5.2.5.1	Cast Iron	89
5.2.5.2	Steel	89
5.2.5.3	Ductile Iron Pipes	89
5.2.6	Plastic Pipes	90
5.2.6.1	General	90
5.2.6.2	PVC Pipes	90
5.2.6.3	High Density Polyethylene (HDPE) Pipes	90
5.2.7	Glass Fibre Reinforced Plastic Pipes	90
5.2.7.1	Fibre Glass Reinforced Plastic Pipes (FRP)	91
5.2.8	Pitch Fibre Pipes	91
5.3	JOINTING IN SEWER PIPES	91
6	STRUCTURAL DESIGN OF BURIED SEWERS	92
6.1	INTRODUCTION	92
6.2	TYPE OF LOADS	92
6.3	LOADS ON CONDUITS DUE TO BACKFILL	93
6.3.1	Types of Installation or Construction Conditions	93
6.3.2	Loads for Different Conditions	95
6.3.2.1	Embankment or Projecting Conduit Condition	95
6.3.2.2	Trench Condition	104
6.3.2.3	Tunnel Condition	107
6.3.2.4	Effect of Submergence	111

VIII

6.4	LOAD ON CONDUIT DUE TO SUPER IMPOSED LOADS	111
6.4.1	Concentrated Load	113
6.4.2	Distributed Load	113
6.4.3	Conduits Under Railway Track	115
6.5	SUPPORTING STRENGTH OF RIGID CONDUIT	115
6.5.1	Laboratory Test Strength	116
6.5.2	Field Supporting Strength	116
6.5.3	Supporting Strength in Trench Conditions	116
6.5.3.1	Classes of Bedding	116
6.5.3.2	Load Factors	118
6.5.4	Supporting Strength in Embankment Conditions	118
6.5.4.1	Classes of Bedding	120
6.5.4.2	Load Factors	120
6.5.5	Conduits Under Simultaneous Internal Pressure and External Loading	122
6.6	RELATIONSHIP BETWEEN THE DIFFERENT ELEMENTS IN STRUCTURAL DESIGN	123
6.7	RECOMMENDATIONS	123
6.8	ILLUSTRATIVE EXAMPLES	124
7	CONSTRUCTION OF SEWERS	126
7.1	CONSTRUCTION METHODS	126
7.1.1	Trench	126
7.1.1.1	Dimensions	126
7.1.1.2	Excavation	126
7.1.1.3	Shoring	126
7.1.1.4	Underground Services	127
7.1.1.5	Dewatering	127
7.1.1.6	Foundation and Bedding	127
7.1.2	Tunnelling	127
7.1.2.1	Shafts	128
7.1.2.2	Methods of Tunnelling	128

7.1.3	Laying of Pipe Sewers	129
7.1.3.1	Stoneware Pipes	129
7.1.3.2	R.C.C. Pipes	129
7.1.3.3	Cast-In-situ Concrete Sections	129
7.1.3.4	Construction of Brick Sewers	130
7.1.3.5	Cast Iron Pipes	130
7.1.4	Jointing of Sewers	130
7.1.4.1	Stoneware Pipes	130
7.1.4.2	Concrete Pipes	130
7.1.4.3	C.I. Pipes	131
7.1.5	Hydraulic Testing of Pipe Sewers	131
7.1.5.1	Water Test	131
7.1.5.2	Air Testing	132
7.1.6	Check for Obstruction	132
7.1.7	Construction of Manholes	132
7.1.8	Sewer Connections	133
7.1.9	Backfilling of the Trenches	133
7.1.10	Removal of Sheet piling	133
8	MAINTENANCE OF SEWERAGE SYSTEMS	134
8.1	INTRODUCTION	134
8.2	TYPES OF MAINTENANCE	134
8.3	NECESSITY OF MAINTENANCE	134
8.4	ORGANISATION FOR MAINTENANCE	134
8.5	PROVISIONS IN DESIGN	135
8.6	HOUSE CONNECTIONS	135
8.7	PLANNING FOR SEWER MAINTENANCE	135

8.8	SEWER CLEANING EQUIPMENT AND PROCEDURES	136
8.8.1	Portable Pump Set	136
8.8.2	Manila Rope and Cloth Ball	136
8.8.3	Sectional Sewer Rods	137
8.8.4	Sewer Cleaning Bucket Machine	137
8.8.5	Dredger (Clam-shell)	137
8.8.6	Roding Machine with Flexible Sewer Rods	137
8.8.7	Scraper	141
8.8.8	Hydraulically Propelled Devices	141
8.8.8.1	Flush Bags	141
8.8.8.2	Sewer Balls	141
8.8.8.3	Sewer Scooters	142
8.8.9	Velocity Cleaners (Jetting Machines)	142
8.8.10	Suction Units (Gully Emptier)	142
8.8.11	Pneumatic Plugs	144
8.9	HAZARDS	144
8.9.1	Gases In Sewerage System	144
8.10	PRECAUTIONS	145
8.10.1	Traffic Control	145
8.10.2	Manhole Safety	145
8.10.3	Infection	146
8.10.4	Precautions of Pumping Stations	146
8.10.5	Precautions Against Electrical Shocks	147
8.11	SAFETY EQUIPMENT	147
8.11.1	Gas Masks	147
8.11.2	Breathing Apparatus	148
8.11.2.1	Air Hose Respirator	148

8.11.3	Portable Lighting Equipment	148
8.11.4	Nonsparking Tools	148
8.11.5	Portable Air Blowers	148
8.11.6	Safety Belt	149
8.11.7	Inhalators	149
8.11.8	Diver's Suit	149
8.12	EMERGENCY MAINTENANCE	149
8.13	INSPECTION	150
8.13.1	Necessity for Inspection	150
8.13.2	Type of Inspection	150
8.13.3	Direct Inspection	150
8.13.4	Indirect Inspection	150
8.13.5	Planning for Sewer Inspection	151
8.14	SEWER REHABILITATION	151
8.14.1	Methods	151
8.14.2	Sewer Renovation	151
8.15	SAFETY PRACTICES	152
8.15.1	Safety Practice Programme	152
8.15.2	Keeping Records of Injury	152
8.15.3	Searching out Hazards	153
8.15.4	Safe Equipment, Working Methods	153
8.15.4.1	Motivation and Training	153
8.15.4.2	Changing Working Habits	153
8.16	RECORDS	153
8.16.1	Maps and Profiles	153
8.16.2	Data	153

9	SEWAGE AND STORM WATER PUMPING STATIONS	154
9.1	GENERAL CONSIDERATIONS	154
9.2	LOCATION	154
9.3	CAPACITY	154
9.4	TYPES OF PUMPING STATIONS	154
9.5	STRUCTURE AND LAYOUT OF THE PUMPHOUSE	155
9.5.1	Provision of Essential Accessories	155
9.5.2	Provisions for Functional Requirements	155
9.5.2.1	Ventilation	155
9.5.2.2	Safety Measures	155
9.5.2.3	Other Facilities	156
9.6	DESIGN CONSIDERATIONS FOR THE DRY AND WET WELLS	156
9.6.1	Dry Well	156
9.6.2	Wet Well	156
9.7	PUMPS	158
9.7.1	Capacity	158
9.7.2	Size of the Pump	158
9.7.3	Pump-Types	158
9.7.4	Centrifugal Pumps	158
9.7.5	Computation of the Total Head of Pumping	161
9.7.5.1	System Head	161
9.7.5.2	Operating Point of a Centrifugal Pump	163
9.7.5.3	Parallel Operation	163
9.7.5.4	Stable Characteristics	163
9.7.5.5	Cavitation	165
9.7.6	Progressive Cavity, Helical Rotor Pumps	165
9.7.7	Installation of Pumps	166
9.7.8	Operation of the Pumps	169
9.7.9	Maintenance of Pumps	169

9.7.9.1	Daily Observations	169
9.7.9.2	Semi-Annual	170
9.7.9.3	Annual Inspection	170
9.7.9.4	Facilities for Maintenance and Repairs	170
9.7.10	Trouble-Shooting	171
9.7.10.1	Check Chart for Centrifugal Pump Troubles	171
9.7.10.2	Check-Chart for Reciprocating Pump Troubles	174
9.7.10.3	Check-Chart for Rotary Pump Troubles	175
9.8	PRIME MOVERS	176
9.8.1	Selection Criteria	176
9.8.2	Constructional Features of Induction Motors	176
9.8.3	Method of Starting	177
9.8.4	Voltage Ratings	177
9.8.5	Types of Enclosure	177
9.8.6	Class of Duty	178
9.8.7	Insulation	178
9.8.8	Margin in Brake Kilowatts (BkW)	178
9.9	ELECTRICAL EQUIPMENT	178
9.9.1	Switch Gear	179
9.9.2	Starters	179
9.9.3	Capacitors	180
9.9.4	Cables	180
9.10	CONTROLS	180
9.11	MAINTENANCE AND REPAIRS OF ELECTRICAL EQUIPMENT	181
9.11.1	Facilities for Maintenance and Repairs	181
9.11.2	Preventive Maintenance	181
9.11.2.1	Daily	182
9.11.2.2	Monthly	182
9.11.2.3	Quarterly	182
9.11.2.4	Semi-Annual	183
9.11.2.5	Annual	183
9.11.2.6	Bi-Annual	184

9.12	TROUBLE SHOOTING FOR ELECTRICAL EQUIPMENTS	184
9.12.1	Motor gets overheated	184
9.12.2	Motor gets overloaded	184
9.12.3	Starter/Breaker Trips	184
9.12.4	Vibration in Motor	185
9.12.5	Cables Get Overheated	185
10	BASIC DESIGN CONSIDERATIONS	186
10.1	DEGREE OF TREATMENT	186
10.2	DESIGN PERIOD	186
10.3	POPULATION SERVED	187
10.4	SEWAGE FLOWS	187
10.4.1	Population Equivalent	187
10.5	SEWAGE CHARACTERISTICS	187
10.5.1	Temperature	187
10.5.2	Hydrogen Ion Concentration	187
10.5.3	Colour and Odour	188
10.5.4	Solids	188
10.5.5	Nitrogen	188
10.5.6	Phosphorus	188
10.5.7	Chlorides	188
10.5.8	Biochemical Oxygen Demand	188
10.5.9	Chemical Oxygen Demand	188
10.5.10	Toxic Metals and Compounds	189
10.6	EFFECT OF INDUSTRIAL WASTES	189
10.7	DUMPING CHUTES FOR NIGHTSOIL	189
10.8	EFFLUENT DISPOSAL AND UTILISATION	190
10.9	UNIT OPERATIONS, PROCESSES AND REACTOR DESIGN PRINCIPLES	190
10.9.1	Unit Operations and Processes	190
10.9.2	Reactors	190
10.9.3	Biological Reactor Design	192
10.9.4	Design of Process Flow Sheets	195
10.10	CHOICE OF PROCESSES	199

11	PRETREATMENT - SCREENING AND GRIT REMOVAL	200
11.1	SCREENING	200
11.1.1	Coarse Screens	200
11.1.2	Medium Screens	201
11.1.3	Fine Screens	201
11.1.4	Comminuting Devices	201
11.1.5	Location of Screens	201
11.1.6	Housing of Screens	201
11.1.7	Hydraulics	201
11.1.8	Velocity	202
11.1.9	Head Loss	202
11.1.10	Quantity of Screenings	203
11.1.11	Disposal of Screenings	203
11.2	GRIT REMOVAL	203
11.2.1	Composition of Grit	203
11.2.2	Types	204
11.2.2.1	Mechanically Cleaned Grit Chambers	204
11.2.2.2	Manually Cleaned Grit Chambers	204
11.2.3	Aerated Grit Chambers	204
11.2.4	Design Data	204
11.2.5	Design of Grit Chambers	205
11.2.5.1	Settling Velocity	205
11.2.5.2	Surface Over Flow Rate	208
11.2.5.3	Detention Period	209
11.2.5.4	Bottom Scour and Flow Through Velocity	209
11.2.5.5	Velocity Control Devices	209
11.2.5.6	Number of Units	213
11.2.5.7	Dimensions of Each Unit	213
11.2.6	Loss of Head	213
11.2.7	Disposal of Grit	213
12	SEDIMENTATION	214
12.1	GENERAL	214
12.2	CHARACTERISTICS OF SETTLEABLE SOLIDS	214

12.3	TYPES OF SETTLING	214
12.3.1	Discrete Settling	214
12.3.2	Flocculent Settling	215
12.3.3	Hindered or Zone Settling	215
12.3.4	Compression	215
12.4	DESIGN CONSIDERATIONS	215
12.4.1	Factors Influencing Design	215
12.4.2	Design Criteria	215
12.4.2.1	Overflow Rate or Surface Loading Rate	215
12.4.2.2	Detention Period	216
12.4.2.3	Solids Loading Rate	216
12.4.2.4	Weir Loading	217
12.4.2.5	Depth	217
12.4.2.6	Sludge Removal	217
12.4.2.7	Inlets and Outlets	218
12.4.2.8	Scum Removal	219
12.4.2.9	Types and Shapes	219
12.5	PERFORMANCE	220
12.6	CHEMICAL-AIDED SEDIMENTATION	220
12.6.1	Chemicals Used	220
12.6.1.1	Iron Salts	221
12.6.1.2	Aluminium Salts	221
12.6.1.3	Lime and Sodium Carbonate	221
12.6.2	Unit Operations	221
12.6.2.1	Mixing	221
12.6.2.2	Flocculation	221
12.6.2.3	Sedimentation	222
13	AEROBIC SUSPENDED GROWTH SYSTEMS	223
13.1	INTRODUCTION	223
13.2	ACTIVATED SLUDGE PROCESS VARIABLES	223
13.2.1	<i>Loading Rate</i>	224
13.2.2	<i>Mixing Regime</i>	226
13.2.3	<i>Flow Scheme</i>	226

13.3	CONVENTIONAL SYSTEM AND MODIFICATIONS	226
13.3.1	<i>Conventional System</i>	227
13.3.2	<i>Completely Mixed</i>	228
13.3.3	<i>Extended Aeration</i>	228
13.4	DESIGN CONSIDERATION	228
13.4.1	Aeration Tank	229
13.4.2	Oxygen Requirements	230
13.4.3	Aeration Facilities	231
13.4.3.1	Diffused Air Aeration	232
13.4.3.2	Surface Aerators	232
13.4.3.3	Mixing Requirements	232
13.4.4	Measuring Devices	233
13.4.5	Secondary Settling	233
13.4.6	Sludge Recycle	233
13.4.7	Excess Sludge Wasting	234
13.4.8	Nitrification	234
13.4.9	Operation	235
13.5	AERATED LAGOONS	236
13.6	DESIGN VARIABLES	237
13.6.1	Mixing Conditions	238
13.6.2	Substrate Removal Rates	241
13.6.3	Power Level	241
13.6.4	Effluent Characteristics	242
13.6.5	Sludge Accumulation	242
13.7	CONCLUSION	242

14	AEROBIC ATTACHED GROWTH SYSTEMS	242 A
14.1	GENERAL CONSIDERATIONS	242 A
14.2	TRICKLING FILTERS	242 A
14.2.1	Process Description	242 A
14.2.2	Types of Filters	243
14.2.3	Process Design	244
14.2.3.1	Rankin's Equation	246
14.2.3.2	National Research Council (Canada) Equation	246
14.2.3.3	Eckenfelder Equation	247
14.2.3.4	Applicability of the Different Equations	248
14.2.4	Constructional Features	249
14.2.4.1	Shape of Filter	249
14.2.4.2	Provision for Filter Flooding	249
14.2.4.3	Filter Walls	249
14.2.4.4	Filter Floor	249
14.2.4.5	Under-Drainage System	249
14.2.4.6	Main Collecting Channel	250
14.2.4.7	Ventilation	250
14.2.4.8	Filter Media	250
14.2.4.9	Plastic Media	251
14.2.4.10	Filter Dosing	251
14.2.4.11	Flow Distribution	251
14.2.5	Multiple Units	252
14.2.6	Plant Hydraulics	253
14.2.7	Pumping Arrangements	253
14.2.8	Operational Problems	253

14.3	ROTATING BIOLOGICAL CONTACTOR	254
14.3.1	Process Description	254
14.3.2	Constructional Features	254
14.3.3	Design and Operational Parameters	255
15	STABILIZATION PONDS	256
15.1	CLASSIFICATION	256
15.1.1	Aerobic	256
15.1.2	Anaerobic	256
15.1.3	Facultative	256
15.2	MECHANISM OF PURIFICATION	256
15.2.1	Aerobic and Anaerobic Reactions	257
15.2.2	Diurnal Variations	257
15.2.3	Odour Control	257
15.2.4	Algae	257
15.3	DESIGN CONSIDERATIONS	258
15.3.1	Areal Organic Loading	258
15.3.2	Detention Time and Hydraulic Flow Regimes	259
15.3.3	Depth	260
15.3.4	Sludge Accumulation	260
15.3.5	Bacterial Reduction	260
15.4	CONSTRUCTION DETAILS	260
15.4.1	Site Selection	260
15.4.2	Pretreatment	261
15.4.3	Construction in Stages	261
15.4.4	Multiple Units	261
15.4.5	Pond Shape	261

15.4.6	Embankment	261
15.4.7	Pond Bottom	262
15.4.8	Pond Inlets	262
15.4.9	Pond Outlets	262
15.4.10	Pond Interconnections	263
15.4.11	Other Aspects	263
15.5	OPERATION AND MAINTENANCE	263
15.6	PERFORMANCE	263
15.7	APPLICATIONS	264
16	ANAEROBIC TREATMENT OF WASTEWATERS	265
16.1	INTRODUCTION	265
16.2	HIGH RATE ANAEROBIC SYSTEMS	265
16.2.1	Anaerobic Contact Process	265
16.2.2	Anaerobic Filter	265
16.2.3	Anaerobic Fixed Films Reactor	266
16.2.4	Fluidized and Expanded Bed Reactor	266
16.2.5	Upflow Anaerobic Sludge Blanket Reactor	266
16.3	DESIGN AND OPERATIONAL CONSIDERATIONS	266
16.3.1	Organic Load and Sludge Retention Time	266
16.3.2	Hydraulic Load	268
16.3.3	Effect of Temperature	268
16.3.4	Excess Sludge Production and Nutrient Requirement	268
16.3.5	Toxicity	268
16.3.6	Recirculation	268
16.3.7	Gas Yield and Utilization	268
16.4	PRETREATMENT	269
16.5	EFFLUENT QUALITY AND POST TREATMENT	269

17	SLUDGE THICKENING, DEWATERING, DIGESTION AND DISPOSAL	270
17.1	INTRODUCTION	270
17.2	SLUDGE THICKENING	270
17.2.1	Gravity Thickening	270
17.2.2	Air Floatation	271
17.2.3	Centrifugation	272
17.3	SLUDGE DEWATERING	272
17.3.1	Sludge Drying Beds	272
17.3.1.1	Design Criteria	272
17.3.2	Mechanical Methods	274
17.3.2.1	Sludge Conditioning	275
17.3.2.2	Equipments	276
17.3.3	Heat Drying	277
17.3.4	Incineration	277
17.4	SLUDGE DIGESTION	277
17.4.1	Anaerobic Digestion	277
17.4.1.1	Microbiology of the Process	277
17.4.1.2	Types	279
17.4.1.3	Digester Capacity	280
17.4.1.4	Sizing of Low Rate Digesters	283
17.4.1.5	Sizing of High Rate Digesters	285
17.4.1.6	Digester Elements	285
17.4.1.7	Performance of Digesters	292
17.4.2	Aerobic Digestion	293
17.4.3	Merits and demerits of anaerobic digestion	293
17.5	SLUDGE DISPOSAL	294
17.5.1	Sludge as Fertilizer	294
17.5.2	Sludge Lagooning	295
17.5.3	Land Fill	295
17.5.4	Disposal in Water or Sea	295

18	SLUDGE PUMPING	296
18.1	GENERAL CONSIDERATIONS	296
18.2	SLUDGE-PUMPING	296
18.3	SLUDGE PUMPS	297
18.3.1	Centrifugal Pumps	298
18.3.2	Air-Lift Pumps	298
18.3.3	Screw Pumps	298
18.3.4	Reciprocating Plunger or Diaphragm Pumps	298
18.4	OPERATIONAL PROBLEMS	299
18.5	REQUIREMENT OF STANDBY UNITS	299
18.6	SLUDGE CONVEYING PIPING	299
18.7	PUMP APPURTENANCES	300
18.7.1	Air Chamber	300
18.7.2	Revolution Counter	300
18.7.3	Gland Seals	300
18.7.4	Valves	300
18.7.5	Gauges	301
18.7.6	Sampling Devices	301
18.7.7	Washouts and Drains	301
18.7.8	Time clocks	301
18.7.9	Measuring Devices	301
18.8	PUMP DRIVE EQUIPMENT	302
19	TERTIARY TREATMENT OF SEWAGE FOR REUSE	303
19.1	GENERAL	303
19.2	BASIC APPROACH	303
19.3	TERTIARY TREATMENT METHODS	304
19.4	DESIGN CRITERIA	305

XXIII

19.5	REUSE FOR INDUSTRIAL PURPOSES	306
19.5.1	As Cooling Water	306
19.5.2	As Boiler Feed Water	310
19.5.3	As Process Water	313
19.6	REUSE FOR AGRICULTURAL PURPOSES	315
19.7	REUSE BY GROUND WATER RECHARGE	315
20	EFFLUENT DISPOSAL AND UTILISATION	318
20.1	GENERAL	318
20.2	DISPOSAL INTO WATER BODIES	318
20.2.1	Disposal into River	318
20.2.2	Disposal into Estuaries	318
20.2.3	Disposal into Ocean	318
20.2.4	Basic Information	319
20.3	RECLAMATION OF TREATED EFFLUENT	319
20.4	PISCICULTURE	320
20.5	ARTIFICIAL RECHARGE OF AQUIFERS	320
20.6	DISPOSAL ON LAND	320
20.6.1	Sewage Farming	320
20.7	WATER QUALITY CONSIDERATIONS FOR IRRIGATION WATERS	320
20.7.1	Osmotic Effects	321
20.7.2	Toxic Effects	322
20.7.3	Impairment of Soil Quality	324
20.7.3.1	Sodium Hazard	324
20.7.3.2	Organic Solids	325
20.7.4	Other Considerations	325
20.8	DESIGN AND MANAGEMENT OF SEWAGE FARMS	326
20.8.1	Management of Water in Sewage Farming	326
20.8.1.1	Hydraulic Loading	327
20.8.1.2	Organic Loading	328
20.8.1.3	Irrigation Interval	328

XXIV

20.8.2	Management of Soil	328
20.8.3	Utilisation of Plant Nutrients	329
20.8.4	Land requirements	329
20.9	ALTERNATIVE ARRANGEMENTS DURING NON-IRRIGATING PERIODS	330
20.10	PROTECTION AGAINST HEALTH HAZARDS	330
20.11	STANDARDS	331
21	ON-SITE SANITATION	333
21.1	BACKGROUND	333
21.2	SEPTIC TANK	333
21.2.1	Design	333
21.2.2	Construction Details	335
21.2.3	Sludge Withdrawal and Disposal	335
21.2.4	Secondary Treatment and Disposal of Effluent	337
21.2.4.1	Soak Pits	337
21.2.4.2	Dispersion Trenches	338
21.2.4.3	Up-Flow Anaerobic Filter	338
21.3	POUR FLUSH WATER SEAL LATRINES	338
21.3.1	Design and Materials	339
21.3.1.1	Squatting Pan, Trap, Footrests and Connecting Drain	339
21.3.1.2	Super Structure	339
21.3.1.3	Leach Pits	341
21.3.2	Construction of Pour Flush Latrine	343
21.3.2.1	Squatting Pan and Trap	343
21.3.2.2	Foot-Rests	349
21.3.2.3	Pit Lining	349
21.3.2.4	Pit Bottom	349
21.3.2.5	Pit Cover	349
21.3.2.6	Leach Pit Connection	349
21.3.3	Pollution Safeguards	349
21.3.3.1	Safe Distance From Drinking Water Sources	350
21.3.3.2	Safe Distance From Water Supply Mains	350
21.3.3.3	Location of Pits	350
21.3.3.4	Sub-Soil Conditions	351

21.4	AN OVERVIEW OF OTHER ALTERNATIVE ON-SITE SANITATION METHODS	351
21.4.1	Bucket/Dry Latrine	351
21.4.2	Trench Latrine (Shallow Type)	352
21.4.3	Bore Hole latrine	352
21.4.4	Dug well Latrine	352
21.4.5	Aqua Privy	352
21.4.6	Ventilated Improved Pit Latrine (VIP Latrine)	352
21.5	NIGHT SOIL DIGESTERS	353
21.5.1	Design Criteria	353
21.6	MINI PACKAGE TREATMENT PLANTS	353
22	CORROSION PREVENTION AND CONTROL	354
22.1	GENERAL	354
22.2	CORROSION OF SEWERS	354
22.2.1	Corrosion due to Biological Reactions	354
22.2.2	Factors Influencing Sulphide Generation	355
22.2.2.1	Temperature	355
22.2.2.2	Strength of Sewage	355
22.2.2.3	Velocity of Flow	355
22.2.2.4	Age of Sewage	356
22.2.2.5	Hydrogen Ion Concentration	356
22.2.2.6	Sulphate Concentration	356
22.2.2.7	Ventilation	356
22.2.3	Sulphide Control Procedures	356
22.2.3.1	Design of sewers	357
22.2.3.2	Control of Sewage Character	357
22.2.3.3	Cleaning of Sewers	358
22.2.3.4	Chlorination	358
22.2.4	Materials of Construction	358
22.2.5	Sewer-Protection	359
22.2.5.1	Liners	359
22.2.5.2	Protective Coatings	359
22.2.5.3	Cathodic Protections	360
22.2.5.4	Protection by Sacrificial Anode	362

XXVI

22.3	CORROSION OF TREATMENT SYSTEMS	363
22.3.1	Neutralisation Tanks	363
22.3.2	Sedimentation Tanks	363
22.3.3	Sludge Digestion	363
22.3.4	Activated Sludge	364
22.3.5	Trickling Filters	364
22.3.6	Sewage and waste water pumps	364
22.3.7	Preventive Maintenance	365
22.3.8	Piping Requirements In Treatment Plants	365
22.3.9	Modification of Materials	366
23	TREATMENT PLANT OPERATION AND MAINTENANCE	367
23.1	INTRODUCTION	367
23.2	TREATMENT UNITS	368
23.2.1	Screens	368
23.2.2	Grit Chamber	369
23.2.3	Sedimentation Tanks	369
23.2.3.1	Sludge	369
23.2.3.2	Bulking and Rising of Sludge	369
23.2.3.3	Skimmings	370
23.2.3.4	Structures and Mechanical Equipments	370
23.2.3.5	Records	370
23.2.4	Aeration Tanks	370
23.2.4.1	Sewage Flow	371
23.2.4.2	Air Supply	371
23.2.4.3	Mixed Liquor Suspended Solids	371
23.2.4.4	Return Sludge	371
23.2.4.5	Foaming	371
23.2.4.6	Microscopic Examination	372
23.2.4.7	Records	372
23.2.5	Trickling Filters	372
23.2.5.1	Distributors	372
23.2.5.2	Ponding	372
23.2.5.3	Underdrains	373

23.2.5.4	Odour	373
23.2.5.5	Filter Flies	373
23.2.5.6	Records	373
23.2.6	Sludge Digestion Tanks	373
23.2.6.1	Digester Operation	373
23.2.6.2	Records	374
23.2.7	Sludge Drying Beds	374
23.2.8	Stabilization Ponds	375
23.2.8.1	Operation and Maintenance of Facultative Pond	375
23.2.8.2	Records	376
23.3	BUILDING AND EQUIPMENT	376
23.3.1	Building and other Structures	376
23.3.2	Equipments	377
23.4	SAFETY IN THE PLANT	377
23.5	TRAINING OF PERSONNEL	378
23.6	RECORDING AND REPORTING	378
23.7	CHECK LIST	379
24	PLANT CONTROL LABORATORY	380
24.1	GENERAL	380
24.2	PLANNING OF LABORATORY FACILITIES	380
24.2.1	Physical Facilities	380
24.2.1.1	Size of The Laboratory	380
24.2.1.2	Location	380
24.2.1.3	Floor space	380
24.2.1.4	Walls	382
24.2.1.5	Lighting	382
24.2.1.6	Power Supply	382
24.2.1.7	Floor	382
24.2.1.8	Work Tables and Benches	382
24.2.1.9	Reagent Cabinets and Cupboards	382
24.2.1.10	Sinks	382
24.2.1.11	Fume Hoods and Chambers	383
24.2.1.12	Gas Supply	383
24.2.1.13	Space for Analytical Balance	383

XXVIII

24.2.1.14	Constant Temperature Room	383
24.2.1.15	Sample Preparation Room	383
24.2.1.16	Media Preparation and Sterilization Rooms	383
24.2.1.17	Space for Records	383
24.2.1.18	Wash and Toilet Facilities	383
24.2.2	Equipment and Chemicals	384
24.2.2.1	Equipment Required	384
24.2.2.2	Storage	384
24.3	SAMPLING OF SEWAGE AND WASTEWATER	384
24.3.1	Methods of Sampling	385
24.3.1.1	Grab Samples	385
24.3.1.2	Composite or Integrated Samples	385
24.3.2	Sample Volumes	385
24.3.3	Selection of Sampling Points	385
24.4	TESTS PERFORMED IN THE LABORATORY	386
24.4.1	Raw Sewage	386
24.4.2	Primary Sedimentation Tanks	386
24.4.3	Trickling Filters	386
24.4.4	Activated Sludge Aeration Tanks	386
24.4.5	Secondary Settling Tanks	387
24.4.6	Septic Tanks and Clarifiers	387
24.4.7	Sludge Digester	387
24.4.8	Stabilization Ponds	387
24.4.9	Digester Gas	387
24.4.10	Residual Chlorine	387
24.4.11	Special Tests	387

24.5	DISPOSAL OF LABORATORY WASTES	388
24.5.1	Solid Waste	388
24.5.2	Liquid Wastes	388
24.5.3	Radioactive Wastes	388
24.6	ANALYSIS OF DATA	388
24.7	COMPUTERISATION OF LABORATORY DATA	388
24.8	PERSONNEL	389
25	FLOW MEASUREMENT	390
25.1	INTRODUCTION	390
25.2	METHODS OF FLOW MEASUREMENTS	390
25.2.1	Direct Discharge Methods	390
25.2.1.1	Notches and Weirs	390
25.2.1.2	Flumes (Free Flowing)	399
25.2.1.3	Venturi Meters	400
25.2.1.4	Drops (Fig.25.9)	403
25.2.1.5	California Pipe (Fig.25.10)	403
25.2.1.6	Flow Nozzles (Fig.25.11)	404
25.2.1.7	Orifice Plate (Fig.25.12)	404
25.2.1.8	Magnetic Flow Meters	404
25.2.1.9	Ultrasonic Flowmeters	407
25.2.1.10	Volumetric Measurement	407
25.2.1.11	Dilution Method	407
25.2.1.12	Constant Rate Injection Method	413
25.2.2	Velocity-Area Methods	414
25.2.2.1	Current Meters	414
25.2.2.2	Float Measurements	414
25.2.2.3	Pitot Tubes	414
25.2.2.4	Chemical and Radioactive Tracers	415
25.2.2.5	Dye Tracers	415
25.2.2.6	Conclusion	415

XXX

26	EMERGING TECHNOLOGIES FOR SEWAGE TREATMENT	416
26.1	PREAMBLE	416
26.2	DUCKWEED POND TECHNOLOGY	416
26.2.1	General	416
26.2.2	Process	416
26.2.3	Process Flowsheet	416
26.2.4	Research and Development Needs	416
26.3	VERMICULTURE TECHNOLOGY	417
26.3.1	General	417
26.3.2	Process Description	417
26.3.3	Research and Development Needs	417
26.4	RAW SEWAGE UTILISATION FOR TREE PLANTATION	417
26.5	ROOT ZONE TECHNOLOGY	418
26.5.1	Process	418
26.5.2	Research and Development Needs	418
26.6	CONCLUSION	418

APPENDICES

Appendix No.

A	ABBERRATIONS AND SYMBOLS	419
B	CONVERSION FACTORS	420
C	LIST OF INDIAN STANDARDS RELATING TO SEWERAGE AND SEWAGE TREATMENT	423
1.1	TYPICAL PERFORMANCE CHARACTERISTICS FOR VARIOUS METHODS OF SEWAGE TREATMENT	440
1.2	ESTIMATION OF FUTURE POPULATION	441
3.1	COMPUTATION OF STORM RUNOFF AND DESIGN OF STORM SEWER	445
3.2	MANNINGS CHART	456
3.3	HAZEN WILLIAM CHART	457
3.4	CALCULATION OF BACK WATER CURVE	458
3.5	DESIGN OF SANITARY SEWER SYSTEM	460
3.6	DESIGN OF GRAVITY SANITARY SEWER NETWORK USING COMPUTER PROGRAMME IN BASIC	463
6.1	THREE EDGE BEARING TESTS FOR PIPE STRENGTH	473
6.2	ILLUSTRATIVE EXAMPLES FOR STRUCTURAL DESIGN OF BURIED CONDUITS	474
8.1	CHARACTERISTICS OF COMMON GASES CAUSING HAZARDS	482
8.2	EQUIPMENT AND SIMPLE TESTS FOR DETECTION OF GASES AND OXYGEN DEFICIENCY	484
11.1	EXAMPLE FOR HYDRAULIC DESIGN OF MECHANICALLY CLEANED BAR RACK AND SCREEN CHAMBER	486
11.2	DESIGN EXAMPLE FOR GRIT CHAMBER WITH PROPORTIONAL FLOW WEIR AS HYDRAULIC CONTROL DEVICE	492
12.1	DESIGN OF SECONDARY SEDIMENTATION TANK	496
13.1	DESIGN OF CONVENTIONAL ACTIVATED SLUDGE PROCESS	500
13.2	DESIGN OF FACULTATIVE AERATED LAGOON	502
14.1	DESIGN OF TRICKLING FILTER	504
14.2	DESIGN EXAMPLE OF ROTATING BIOLOGICAL CONTACTOR	520
15.1	DESIGN EXAMPLE OF FACULTATIVE STABILIZATION POND	521
16.1	DESIGN EXAMPLE FOR UPFLOW ANAEROBIC SLUDGE BLANKET REACTOR	524
16.2	DESIGN EXAMPLE FOR ANAEROBIC FILTER	525
17.1	DESIGN EXAMPLE OF SLUDGE DIGESTERS	526

XXXII

17.2	DESIGN EXAMPLE OF SLUDGE DRYING BEDS	531
21.1	SOIL PERCOLATION TEST	533
21.2	DESIGN EXAMPLE OF LEACH PIT	534
23.1	OPERATION TROUBLES IN SEWAGE TREATMENT PLANT	536
23.2	SCHEDULE OF PREVENTIVE MAINTENANCE	540
23.2.1	Centrifugal Pumps	540
23.2.2	Electrical Motors	540
23.3.3	Power Transformers	541
23.3.4	Switchgears (Air or Oil Circuit Breakers)	541
23.3.5	Sedimentation Tanks with Clarifier and their Drive	542
24.1	MINIMUM LABORATORY EQUIPMENTS NEEDED FOR TESTS	543
24.2	TESTS RECOMMENDED TO BE CARRIED OUT ON UNITS OF SEWAGE TREATMENT PLANTS	544
25.1	DESIGN EXAMPLE FOR VENTURI METER	546
27	BIBLIOGRAPHY	550

CHAPTER 1

PLANNING

1.1 OBJECTIVE

The objective of a public waste water collection and disposal system is to ensure that sewage or excreta and sullage discharged from communities is properly collected, transported, treated to the required degree and finally disposed off without causing any health or environmental problems.

1.2 NEED FOR PLANNING

Waste water disposal systems can be either the on-site type or the kind where water-borne wastes are disposed off-site into a water body or on land. To keep overall costs down, most urban systems today are planned as an optimum mix of the two types depending on various factors

Planning is required at different levels: national, state, regional and community. Though the responsibility of various organizations in charge of planning public waste water disposal systems is different in each case, they still have to function within the priorities fixed by the national and state governments and keep in view overall requirements of the area.

The waste water disposal projects formulated by the various State Sponsoring Authorities at present do not always contain all the essential elements for appraisal. When projects are assessed for their cost benefit ratio and for institutional or funding purposes, they are not amenable for comparative study and appraisal. Also, at times different standards are adopted by the Central and State agencies regarding various design parameters. It is necessary therefore to specify appropriate standards and design criteria and avoid different approaches.

1.3 BASIC DESIGN CONSIDERATIONS

In designing waste water collection, treatment and disposal systems, planning generally begins from the final disposal point going backwards to give an integrated and optimum design to suit the topography and the available hydraulic head, supplemented by pumping if essential. Once the disposal points are tentatively selected, further design is guided by the following basic design considerations:

- Engineering
- Environmental
- Process
- Cost

These considerations are discussed below in detail.

1.3.1 Engineering Considerations

Topographical, engineering and other considerations which figure prominently in project design are noted below:

1. Design period, stage wise population to be served and expected sewage flow and fluctuations

2. Topography of the general area to be served, its slope and terrain. Tentative sites available for treatment plant, pumping stations and disposal works
3. Available hydraulic head in the system upto high flood level in case of disposal to a nearby river or high tide level in case of coastal discharge or the level of the irrigation area to be commanded in case of land disposal
4. Ground water depth and its seasonal fluctuation affecting construction, sewer infiltration, structural design (uplift considerations)
5. Soil bearing capacity and type of strata expected to be met in construction.
6. On site disposal facilities, including the possibilities of segregating the sullage water and sewage and reuse or recycle sullage water within the households

1.3.2 Environmental Considerations

The environmental and socio-economic impacts of a sewage treatment plant may prove adverse during the operation stage. Therefore, the following aspects should be considered during design:

a) *Surface Water Hydrology and Quality*

Hydrological considerations affect the location of outfalls to rivers with regard to protection of nearby water supply intake points either upstream or downstream, especially at low flow conditions in the river. Hydrological considerations also help determine expected dilutions downstream, frequency of floods and drought conditions, flow velocities, travel times to downstream points of interest, navigation etc.

Surface water quality considerations include compliance with treated effluent standards at the discharge point with respect to parameters like BOD, suspended and floating solids, oil and grease, nutrients, coliforms etc. Special consideration may be given to the presence of public bathing ghats downstream. The aquatic ecosystem (including fish) may also need protection in case of rivers through minimum dissolved oxygen downstream, uptake of refractory and persistent substances in the food chain, and protection of other legitimate uses to which the river waters may be put.

b) *Ground Water Quality*

Another environmental consideration is the potential for ground water pollution presented by the treatment units proposed to be built. For example, in certain soils, special precautions may be needed to intercept seepage of sewage from lagoons and ponds. Land irrigation would also present a potential for ground water pollution especially from nitrates.

In case of low cost sanitation methods involving on-site disposal of excreta and sullage waters, ground water pollution may need special attention if the ground water table is high and the soil relatively porous.

c) *Coastal Water Quality*

Shoreline discharges of sewage effluents, though treated, could lead to bacterial and viral pollution and affect bathing water quality of beaches. Discharges have to be made sufficiently offshore to benefit from dilution and natural die-away of organisms before they are washed back to the shoreline by currents. The presence of nutrients could also promote algal growth in coastal waters, especially in bays where natural circulation patterns might keep the nutrients trapped in the water body.

d) *Odour and Mosquito Nuisance*

Odour and mosquito nuisance in the vicinity of sewage treatment plants, particularly in the down-wind direction of prevailing winds, can have adverse impacts on land values, public health and well being and general utility of amenities may be threatened. These factors have to be considered in selecting sites for location of sewage treatment plants and treated sewage irrigation fields.

e) *Public Health*

Public health considerations pervade through all aspects of design and operation of sewage treatment and disposal projects. Some aspects have already been referred to earlier. Public health concepts are built into various bye laws, regulations and codes of practice which must be observed, such as:

- i) effluent discharge standards including permissible microbial and helminthic quality requirements
- ii) standards for control of toxic and accumulative substances in the food chain
- iii) potential for nitrate and microbial pollution of ground waters
- iv) deterioration of drinking water resources including wells
- v) deterioration of bathing water quality
- vi) control measures for health and safety of sewage plant operators and sewage farm workers who are exposed to or handle raw and/or treated sewage.

f) *Landscaping*

Sewage treatment plant structures need not be ugly and unsightly. At no real extra cost, some architectural concepts can be used and the buildings designed to suit the main climates (humid or dry) generally met within India.

Apart from the usual development of a small garden near the plant's office or laboratory, some considerations need to be given to sites for disposal of screenings and grit in an inoffensive manner, general sanitation in the plant area and provision of a green-belt around the treatment plant.

1.3.3 *Process Considerations*

Process considerations involve factors which affect the choice of treatment method, its design criteria and related requirements such as the following:

a) *Waste water Flow and Characteristics*

This constitutes the primary data required for process design. The various parameters to be determined are described in other sections of this manual.

b) Degree of Treatment Required

In case of domestic or municipal sewage, this is considered, for example, in terms of removal of BOD/COD, nutrients (nitrogen and phosphorous), coliforms, helminths etc. Land disposal generally has to meet less stringent discharge standards than disposal to surface waters. Land disposal also has the advantage of giving nutrient removal and is, thus, preferred wherever it is feasible. It is often not enough to aim only at BOD removal and let other items be left to unspecified, incidental removal, whatever may occur. The selection of a treatment process thus, depends on the extent of removal efficiency required for all important parameters and the need to obviate nuisance conditions.

c) Performance Characteristics

The dependability of performance of a process inspite of fluctuations in effluent quality and quantity are very useful attributes in ensuring a stable effluent quality. Similarly, ability to withstand power and operational failures, also form important considerations in choice of process. The more high-rated process, the more sensitive it is in operation. Other processes like digesters, lagoons and ponds may be sensitive to temperature. The choice has to match with the discharge standards to be met in a specific case.

The performance characteristics for some methods of sewage treatment are indicated in Appendix 1.1

d) Other Process Requirements

Various other factors affecting the choice of a process include requirements in terms of:

- land
- power (and its dependability)
- operating (and control) equipment requirement and its indigenous availability
- skilled staff
- nature of maintenance problems
- extent of sludge production and its disposal requirements
- loss of head through plant in relation to available head (to avoid pumping as far as possible)
- ease of stage wise extension of plant with time.

Between land and power requirements, a trade-off is often possible, based on actual costs of the two items. This could well be exploited to get an optimum solution for meeting treatment requirements and giving a dependable performance.

Under Indian conditions, the extent of mechanisation adopted should generally be the minimum possible. The operating equipment and its ancillary control equipment should be easy to operate and maintain (with indigenously available spare parts) as far as possible. From this view point, it is to be noted that, methane gas collection, scrubbing to remove hydrogen sulphide wherever necessary and its conversion to electricity, impose a high level of operation and maintenance skills. The option of gas collection and supply to a nearby industry or area should be favoured during the site selection stage wherever possible.

1.3.4 Cost Considerations

Finally from among the few selected options, the overall costs (capital and operating) have to be determined in order to arrive at the most optimum solution.

Capital costs include all initial costs incurred upto plant start up, such as:

- civil construction, equipment supply and erection costs
- land purchase costs including legal fees, if any
- engineering design and supervision charges
- interest charge on loan during construction period.

Operating costs after start up of plant include direct operating costs and fixed costs, such as:

- amortisation and interest charges on capital borrowings
- direct operation and maintenance costs on
 - staff
 - chemicals
 - fuel and electricity
 - transport
 - maintenance and repairs
 - insurance
 - overheads.

1.4 DESIGN PERIOD

Sewerage projects may be designed normally to meet the requirements over a thirty year period after their completion. The period between design and completion should also be taken into account which should be between three to six years depending on the type and size of the project.

The thirty year period may however be modified in regard to certain components of the project depending on their useful life or the facility for carrying out extensions when required and rate of interest, so that expenditure far ahead of its utilisation is avoided. Necessary land for future expansion/duplication of components should be acquired in the beginning itself. Where expensive tunnels and large aqueducts are involved entailing large capital outlay for duplication, they may be designed for ultimate project requirements.

The project components may be designed to meet the periods mentioned in Table 1.1.

1.5 POPULATION FORECAST

1.5.1 General Considerations

The design population will have to be estimated with due regard to all the factors governing the future growth and development of the project area in the industrial, commercial, educational, social and

administration spheres. Special factors causing sudden immigration or influx of population should also be foreseen to the extent possible.

A judgement based on these factors would help in selecting the most suitable method of deriving the probable trend of the population growth in the area or areas of the project from out of the following mathematical methods, graphically interpreted where necessary.

a) Demographic Method of Population Projection

Population change can occur only in three ways- (i) by births (population gain) (ii) by deaths (population loss) or (iii) migration (population loss or gain depending on whether movement out or movement in occurs in excess). Annexation of an area may be considered as a special form of migration. Population forecasts are frequently obtained by preparing and summing up of separate but related projections of natural increases and of net migration and is expressed as below.

The net effect of births and deaths on population is termed natural increase (natural decrease, if deaths exceed births).

Migration also affects the number of births and deaths in an area and so, projections of net migration are prepared before projections for natural increase.

**TABLE 1.1
DESIGN PERIODS FOR COMPONENTS OF SEWERAGE SYSTEM
AND SEWAGE TREATMENT**

Sl. No.	Component	Recommended Design Period in years	Clarification
1.	Collection System i.e. Sewer Network	30	The system should be designed for the prospective population of 30 years, as its replacement is not possible during its use.
2.	Pumping Stations (Civil Works)	30	Duplicating machinery within the pumping station would be easier/cost of civil works will be economical for full design period.
3.	Pumping Machinery	15	Life of pumping machinery is generally 15 years.
4.	Sewage Treatment Plant	30	The construction may be in a phased manner as initially the flows may not reach the designed levels, and it will be uneconomical to build the full capacity plant initially. (Refer Chapter 10.2).
5.	Effluent disposal and utilisation	30	Provision of design capacities in the initial stages itself is economical.

This method thus takes into account the prevailing and anticipated birth rates and death rates of the region or city for the period under consideration. An estimate is also made of the immigration from and immigration to the community, its growth area wise and the net increase of population is calculated accordingly considering all these factors by arithmetical balancing.

b) *Arithmetical Increase Method*

This method is generally applicable to large and old cities. In this method the average increase of population per decade is calculated from the past records and added to the present population to find out population in the next decade. This method gives a low value and is suitable for well settled and established communities.

c) *Incremental Increase Method*

In this method the increment in arithmetical increase is determined from the past decades and the average of that increment is added to the average increase. This method increases the figures obtained by the arithmetical increase method.

d) *Geometrical Increase Method*

In this method percentage increase is assumed to be the rate of growth and the average of the percentage increase is used to find out future increment in population. This method gives much higher value and is mostly applicable for growing towns and cities having vast scope for expansion.

e) *Decreasing Rate of Growth*

In this method it is assumed that rate of percentage increase decreases and the average decrease in the rate of growth is calculated. Then the percentage increase is modified by deducting the decrease in rate of growth. This method is applicable only in such cases where the rate of growth of population shows a downward trend.

f) *Graphical Method*

In this approach there are two methods. In one, only the city in question is considered and in the second, other similar cities are also taken into account.

i) Graphical method based on single city

In this method the population curve of the city (i.e. the population vs past decades) is smoothly extended for getting future value. This extension has to be done carefully and it requires vast experience and good judgement. The line of best fit may be obtained by the method of least squares

ii) Graphical method based on cities with similar growth pattern

In this method the city in question is compared with other cities which have already undergone the same phases of development which the city in question is likely to undergo and based on this comparison, a graph between population and decades is plotted and extrapolated.

g) *Logistic Method*

The S shaped logistic curve for any city gives complete trend of growth of the city right from beginning to saturation limit of population of the city. This method is applicable for very large cities with sufficient demographic data.

h) *Method of Density*

In this approach the trend in rate of density increase of population for each sector of a city, is found out and population forecast is done for each sector based on the above approach. Addition of sector wise population gives the population of the city.

1.5.2 Final Forecast

While the forecast of the prospective population of a projected area at any given time during the period of design can be derived by any one of the foregoing methods appropriate to each case, the density and distribution of such population within the several areas, zones or districts will again have to be made with a discerning judgement on the relative probabilities of expansion within each zone or district, according to its nature of development and based on existing and contemplated town planning regulations.

Wherever population growth forecast or master plans prepared by town planning or other appropriate authorities are available, the decision regarding the design population should take their figures into account.

Worked out examples for estimation of the future population by some of the methods are given in Appendix 1.2.

1.6 ESTIMATION OF WASTEWATER FLOW

1.6.1 Sources of Waste Water

Sanitary sewage is mostly the spent water of the community draining into the sewer system with some ground water and a fraction of storm water from the area draining into it. Domestic sewage is the wastewater from kitchen, bathroom, lavatory, toilet and laundries. The water supply to the communities already contains mineral organic matters to which human excreta, papers, dirt, other fluid wastes and other substances are added.

Industrial wastewaters vary in composition with industrial operations. Some are relatively clean rinse waters, others are heavily laden with organic or mineral matter, or with corrosive, poisonous, flammable, or explosive substances. Some are so objectionable that they should not be admitted to the public sewerage system. Others contain so little and such unobjectionable waste matters that it is safe to discharge them into storm drains or directly to natural bodies of water. Industrial waste flow should follow the guide lines of the Pollution Board or any other competent authority.

There are two types of sewerage systems viz.

- i) Separate system, where one is designed to cater to the municipal wastewaters and a second to take care of storm water flows and
- ii) Combined system where both municipal wastewater as well as storm water are carried in one network .

For estimation of wastewater flow in the case of a network designed for carrying only municipal wastewaters, allowance is generally made for infiltration of ground water through joints.

1.6.2 Per Capita Wastewater Flow

Rate of wastewater flow depends upon rate of water supply to the community and the rate of ground water infiltration. The details of estimating the quantities of wastewater flow are discussed in 3.1.

1.7 SEWAGE CHARACTERISTICS

Characterisation of wastewater is essential for an effective and economical wastewater management programme. It helps in the choice of treatment methods, deciding the extent of treatment, assessing the beneficial uses of wastewater and utilising the waste purification capacity of natural bodies of water in a planned and controlled manner. While analysis of waste in each particular case

is advisable, data from other similar cities may be utilised during initial stages of planning.

Quality parameters for which sewage is to be tested are discussed in 10.5

1.7.1 Effect of Industrial Waste

Waste from industries can form an important component of sewage flow both in volume and composition. It is therefore necessary to collect detailed data about nature of industries, quantity and character of the waste and their variations which may affect the sewerage system or the sewage treatment process. Quality and character of waste water are to be based on flow measurements and laboratory analysis of the composite samples.

1.8 SURVEY AND INVESTIGATION

Survey and investigation are pre-requisites both for framing of the preliminary report and the preparation of a detailed sewerage project. The engineering and policy decisions taken are dependent on the correctness of the data collected and its proper evaluation.

1.8.1 Basic Information

For an effective investigation, a broad knowledge of the problems likely to be faced during the various phases of implementation of the project is essential. Information on physical, developmental, fiscal and other aspects has to be collected.

1.8.1.1 PHYSICAL ASPECTS

These would necessitate the collection of information relating to:

- a) Topography or elevation difference needed for design of sewers and location of out fall and disposal works
- b) Subsoil conditions, such as types of strata likely to be encountered, depth of ground water table and its fluctuations. In the absence of any records, preliminary data should be collected by putting atleast 3 trial bores or trial pits per hectare
- c) Underground structures like storm drains and appurtenances, city survey stones; utility services like house connections for water supply and sewerage, electric and telephone cables, gas lines and
- d) Location of streets and adjoining areas likely to be merged or annexed.

Possible sources of information are, existing maps and plans showing streets from revenue or town surveys or Survey of India maps. Other sources, are topographical maps of Survey of India if available with existing spot-levels, aerial photographs, photographs of complex surfaces for supplementing the existing instrumental surveys by concerned authorities like Municipalities and Roads Departments.

1.8.1.2 DEVELOPMENTAL ASPECTS

The following should be taken into account:

- a) types of land use, such as commercial, industrial, residential and recreational; extent of areas to be served
- b) density of population, trends of population growth and demographic studies

- c) type and number of industries for determining quantity and nature of wastes and location of their discharge points
- d) existing drainage and sewerage facilities and data relating to them
- e) flow in existing sewers and sewers of similar areas to assess the flow characteristics
- f) historical and socio-economic data
- g) basis of design and information on the maintenance of existing sewers and
- h) effluent disposal sites and their availability.

Possible sources of information are census records, town and metropolitan master plans, regional planning records, land use plan, flow gauging records, stream flow records, meteorological data and Pollution Control Boards.

1.8.1.3 FISCAL ASPECTS

The various factors that will have an important bearing are:

- a) existing policies or commitments of obligation which may affect the financing of the project
- b) outstanding loan amounts and instalments of repayments
- c) availability of Central and State loans, grant-in-aid, loans from other financing bodies such as Life Insurance Corporation, Industrial Development Corporation, HUDCO, International Bank for Reconstruction and Development and other Banks and Institutions
- d) present water rates, sewer-tax and revenue realised from them, size of property plots and land holding, the economic condition of community with respect to their tax-paying capacity and
- e) factors affecting the cost of constructions, operation and maintenance. Some of the information can be obtained from the records relating to Municipal and State Tax Levies, Acts and Rules governing loans, procedures for financing projects and registers and records of the authorities maintaining water supply and sewerage systems.

1.8.1.4 OTHER ASPECTS

The considerations that are likely to influence are:

- a) changes in political boundaries by physical acquisition or merger of adjacent communities or by possible extension of limits
- b) feasibility of multi-regional or multi-municipal systems
- c) prevailing water pollution prevention statutes, other rules and regulations relating to discharge of industrial and domestic wastes
- d) present status of the governmental, semi-governmental or municipal authority sponsoring the project, its capacity, adequacy, effectiveness and the desirability of its modification or necessity of a new organisation to satisfactorily implement and maintain the project and

- e) the inconveniences likely to be caused to the community during execution and the feasibility of minimising them by suitable alignment or location of the components of the system.

Possible sources of information are National Acts, State and Municipal Laws and Byelaws, minutes of the past meetings of the municipal or other governing bodies and discussions with officials, municipal councillors and other local leaders.

1.8.2 Project Surveys

1.8.2.1 PRELIMINARY PROJECT SURVEYS

This is concerned with the broad aspects of the project. Data on aspects such as capacity required, basic arrangement and size, physical features affecting general layout and design, availability of effluent disposal facilities, probable cost and possible methods of financing, shall be collected to prepare an engineering report describing the scope and cost of the project with reasonable accuracy. In framing such estimates, due consideration must be given to the escalation of prices of basic materials and their availability. While extreme precision and detail are not required in this phase, all the basic data obtained must be reliable.

1.8.2.2 DETAILED PROJECT SURVEYS

Surveys for this phase form the basis for the engineering design as well as for the preparation of plans and specifications for incorporation in the detailed project report. In contrast to preliminary survey this survey must be precise and contain contours of all the areas to be served giving all the details that will facilitate the designer to prepare design and construction of plans suiting the field conditions. It should include, inter-alia, network of bench marks and traverse surveys to identify the nature as well as extent of the existing underground structures requiring displacement, negotiation or clearance. Such detailed surveys are necessary to establish rights of way, minimise utility relocation costs, obtain better bids and prevent changing and rerouting of lines.

1.8.2.3 CONSTRUCTION SURVEYS

All control points such as base lines and bench marks for sewer alignment and grade should be established by the engineer along the route of the proposed construction. All these points should be referred adequately to permanent objects.

a) *Preliminary Layouts*

Before starting the work, rights-of-way, work areas, clearing limits and pavement cuts should be laid out clearly to ensure that the work proceeds smoothly. Approach roads, detours, by-passes and protective fencing should also be laid out and constructed prior to undertaking sewer construction work. All layout work must be completed and checked before construction begins.

b) *Setting Line and Grade*

The transfer of line and grade from control points, established by the engineers, to the construction work should be the responsibility of the executing agency till work is completed.

The methods generally used for setting the line and grade of the sewers are discussed in 7.3.1.

The procedure for establishing line and grade where tunnels are to be employed in sewer system are discussed in 7.1.2.

1.9 PROJECT REPORT

1.9.1 General

All projects have to follow distinct stages between the period they are conceived and completed. The various stages are:

Pre-Investment Planning

Identification of a project
Preparation of project report

Appraisal and Sanction

Construction of facilities and carrying out support activities

Operation and Maintenance

Monitoring and feed back

1.9.1.1 PROJECT REPORTS

Project reports deal with all aspects of pre-investment planning and establish the need as well as the feasibility of projects technically, financially, socially, culturally, environmentally, legally and institutionally. For big projects economical feasibility may also have to be examined. Project reports should be prepared in three stages viz. (i) identification report (ii) pre-feasibility report and (iii) feasibility report. Projects for small towns or those forming parts of a programme may not require preparation of feasibility reports. Detailed engineering and preparation of technical specification and tender documents are not necessary for taking investment decisions, since these activities can be carried out during the implementation phase of projects. For small projects, however, it may be convenient to include detailed engineering in the project report, if standard design and drawing can be adopted.

Since project preparation is quite expensive and time consuming, all projects should normally proceed through three stages and at the end of each stage a decision should be taken whether to proceed to the next planning stage and commit the necessary manpower and financial resources for the next stage. Report at the end of each stage should include a time table and cost estimate for undertaking the next stage activity and a realistic schedule for all future stages of project development, taking into consideration time required for review and approval of the report, providing funding for the next stage, mobilising personnel or fixing agency (for the next stage of project preparation) data gathering, physical surveys, site investigations etc.

The basic design of a project is influenced by the authorities/organisations who are involved in approving, implementing, operating and maintaining the project. Therefore the institutional arrangements through which a project will be brought into operation, must be considered at the project preparation stage. Similarly responsibility for project preparation may change at various stages. Arrangements in this respect should be finalised for each stage of project preparation. Some times more than one organisation may have a role to play in the various stages of preparation of a project. It is therefore necessary to identify a single entity to be responsible for overall management and coordination of each stage of project preparation. It is desirable that the implementing authority is identified and those responsible for operation of a project are consulted at the project preparation stage.

1.9.2 Identification Report

Identification report is basically a desk study, to be carried out relying primarily on the existing information. It can be prepared reasonably quickly by those who are familiar with the project area and needs of project components. This report is essentially meant for establishing the need for a project.

indicating likely alternatives which would meet the requirements. It also provides an idea of the magnitude of cost estimates of a project to facilitate bringing the project in the planning and budgetary cycle and makes out a case for obtaining sanction to incur expenditure for carrying out the next stages of project preparation. The report should be brief and include the following information:

- a) identification of the project area and its physical environment
- b) commercial, industrial, educational, cultural and religious importance and activities in and around the project area (also point out special activities or establishments like defence or others of national importance)
- c) existing population, physical distribution and socio-economic analysis
- d) present wastewater disposal arrangements in the project area, pointing out deficiencies, if any, in system of collection and treatment
- e) population projection for the planning period, according to existing and future land use plans or master plans, if any
- f) establish the need for taking up a project in the light of existing and future deficiencies in waste water disposal services, pointing out adverse impacts of non-implementation of the project, on a time scale
- g) bring out, how the project would fit in with the national/regional/sectoral strategies and with the general overall development in the project area
- h) identify a strategic plan for long term development of waste water disposal services in the project area, in the context of existing regional development plans and such other reports, indicating phases of development
- i) state the objectives of the short term project under consideration, in terms of population to be served and the impact of the project after completion, clearly indicating the design period
- j) identify project components, with alternatives if any; both physical facilities and supporting activities
- k) preliminary estimates of costs (component-wise) of construction of physical facilities and supporting activities, cost of operation and maintenance
- l) identify source for financing capital works and operation and maintenance. work out annual burden (debt servicing + operational expenditure)
- m) indicate institutions responsible for project approval, financing, implementation, operation and maintenance (e.g. Central Government, State Government, Zilla Parishad, Local Body, Water Supply Boards)
- n) indicate organisation responsible for preparing the project report (pre-feasibility report, feasibility report), cost estimates for preparing project report and sources of funds to finance preparation of project reports
- o) indicate time table for carrying out all future stages of the project and the earliest date by which the project might be operational
- p) indicate personnel strength required and training needs for implementation of the project. indicate if any particular/peculiar difficulties of policy or other nature that are likely to be encountered for implementing the project and how these could be resolved

- q) recommend actions to be taken to proceed further

The following plans may be enclosed with the report:

- i) an index plan to a scale of 1 cm = 2 Km showing the project area, existing works, proposed works and location of community/ township or institution to be served
- ii) a schematic diagram showing the salient levels of project component.

1.9.3 Prefeasibility Report

After clearance is received, on the basis of identification report from the concerned authority and/or owner of the project and commitments are made to finance further studies, the work of preparation of pre-feasibility report should be undertaken by an appropriate agency, which may be a central planning and design cell of the Dept. dealing with Wastewater Board, Local Body, or professional consultants working in the water supply-sanitation environmental areas. In the latter case terms of reference for the study and its scope should be carefully set out. Pre-feasibility study may be a separate and discrete stage of project preparation or it may be the first stage of a comprehensive feasibility study. In either case it is necessary that it precedes taking up of a feasibility study because the prefeasibility study is essentially carried out for screening and ranking of all project alternatives, and to select an appropriate alternative for carrying out detailed feasibility study. The pre-feasibility study helps in selecting a short term project which will fit in the long term strategy for improving services in the context of overall perspective plan for development of the project area.

A pre-feasibility report can be taken to be a Preliminary Project Report, the structure and component of which are as follows:

- i) executive summary
- ii) introduction
- iii) the project area and the need for a project
- iv) long term plan for wastewater disposal
- v) proposed wastewater disposal project
- vi) conclusions and recommendations
- vii) tables, figures/maps and annexes.

1.9.3.1 EXECUTIVE SUMMARY

It is a good practice to provide an Executive Summary at the beginning of the report, giving its essential features, basic strategy, approach adopted in developing the project and the salient features of financial and administrative aspects.

1.9.3.2 INTRODUCTION

This section explains the origin and concept of the project, how it was prepared and the scope and status of the report. These sub-sections may be detailed as under:

a) *Project Genesis*

- i) describe how the idea of the project originated, agency responsible for promoting the project

- ii) list and explain previous studies and reports on the project, including the project identification report and agencies which prepared them
- iii) describe how the project fits in the regional development plan, long term sector plan, land use plan, public health care and wastewater management programme etc.

b) *How was the Study Organised*

- i) explain how the study was carried out, agencies responsible for carrying out the various elements of work and their role in preparing the study
- ii) time table followed for the study.

c) *Scope and Status of the Report*

- i) how the pre-feasibility report fits in the overall process of project preparation
- ii) describe data limitation
- iii) list interim reports prepared during the study
- iv) explain if the pre-feasibility report is intended to be used for obtaining approval for the proposed project.

1.9.3.3 PROJECT AREA AND THE NEED FOR THE PROJECT

This section establishes the need for the project. It should cover the following:

a) *Project Area*

- i) give geographical description of the project area with reference to maps
- ii) describe special features such as topography, climate, culture, religion, migration, etc., which may effect project design, implementation and operation
- iii) map showing administrative and political jurisdiction
- iv) describe any ethnic, cultural or religious aspects of the communities which may have a bearing on the project proposal.

b) *Population Pattern*

- i) Estimate population in the project area, indicating the sources of data or the basis for the estimate
- ii) review previous population data, historic growth rates and causes
- iii) estimate future population growth with different methods and indicate the most probable growth rates and compare with past population growth trends
- iv) compare growth trends within the project area, with those for the region, state and the entire country
- v) discuss factors likely to affect population growth rates

- vi) estimate probable densities of population in different parts of the project area at future intervals of time e.g. five, ten and twenty years ahead
- vii) discuss patterns of seasonal migration if any within the area
- viii) indicate implication of the estimated growth pattern on housing and other local infrastructure.

c) *Economic and Social Conditions*

- i) describe present living conditions of the people of different socio-economic and ethnic groups
- ii) identify locations according to income levels or other indications of socio-economic studies
- iii) show on the project area map location-wise density of population, poverty groups and ethnic concentrations and the present and future land uses (as per development plan)
- iv) information on housing conditions and relative proportions of owners and tenants
- v) provide data on education, literacy and un-employment by age and sex
- vi) provide data and make projection on housing standards and average household occupancy in various parts of the project area
- vii) describe public health status within the project area with particular attention to diseases related to water and sanitary conditions
- viii) provide data on maternal and infant mortality rates and life expectancy
- ix) discuss the status of health care programmes in the area, as well as other projects which have bearing on improvements in environmental sanitation.

d) *Sector Institutions*

- i) Identify the institutions (Government, Semi-Government, Non-Government) which are involved in any of the stages of water supply and sanitation project development in the area, (Planning, preparing projects, financing, implementation, operation and maintenance and evaluation)
- ii) comment on roles, responsibilities and limitation (territorial or others) of all the identified institutions, in relation to water supply and sanitation (This may also be indicated on a diagram).

e) *Existing Wastewater, Disposal Systems and Population Served*

Describe each of the existing wastewater disposal systems in the project area, indicating the details as under:

Area served, quantity and quality of wastewater collected, components of the system such as collection network, pumping stations, treatment works and effluent disposal methods etc.

Private waste water disposal methods such as septic tanks, on site latrines etc.

f) *Drainage and Solid Wastes*

Briefly describe existing systems of storm water drainage and solid waste collection and disposal. This discussion should be focused in terms of their impact on wastewater management and environment.

g) Need for a Project

- i) Comment as to why the existing system cannot satisfy the existing and projected demands for services with reference to population to be served
- ii) Describe the consequences of not taking up a project, (which may include rehabilitation or developing a new system)
- iii) Indicate priorities to improvement of existing system, expansion of systems, construction of new system, assessment of the need for consumer education in hygiene and comments on urgency of project preparation and implementation.

1.9.3.4 LONG TERM PLAN FOR WASTEWATER DISPOSAL

- a) Wastewater disposal services have to be planned as a phased development programme and any short term project should be such as would fit in the long term strategy. Such a long term plan or the strategic plan should be consistent with the future overall development plans for the areas. A long term plan may be prepared for a period of 30 years and alternative development sequences may be identified to provide target service coverage at affordable costs. From these alternative development sequences, a priority project to be implemented in short term can be selected. It is this project which then becomes the subject of a comprehensive feasibility study.
- b) Alternative development sequences should be identified in the light of the coverages to be achieved during the planning period in phases. This calls for definition of the following:
 - i) population to be covered with improved waste water management facility
 - ii) target dates by which the above mentioned coverage would be extended within the planning period, in suitable phases
 - iii) consistency and co-ordination to be maintained between projections for both water supply and sanitation services.
- c) It must be noted that availability of funds is one of the prime factors which will ultimately decide the scope and scale of a feasible project
- d) Selection of a Strategic Plan

Each of the alternative development sequences, which can overcome the existing deficiencies and meet the present and future needs, consists of a series of improvements and expansions to be implemented over the planned period. Since all needs cannot be satisfied in immediate future, it is necessary to carefully determine priorities of target groups for improvement in services and stages of development and thus restrict the number of alternatives.
- e) Planning for system requirement includes consideration of the following:
 - i) possibilities of rehabilitating and/or de-bottlenecking the existing systems
 - ii) alternative treatment systems and pumping schemes
- f) It may also be necessary to ascertain if supporting activities like health education, staff training and institutional improvements etc., are necessary to be included as essential components of

the project. All the physical and supporting input need to be carefully costed (capital and operating) after preparing preliminary designs of all facilities identified for each of the development sequences. These may then be evaluated for least cost solution by 'net present worth' method, which involves expressing all costs (capital and operating) for each year in economic terms, discounting future costs to present value, selecting the sequence with the lowest present value

- g) As stated above, costs are to be expressed in economic terms and not in terms of their financial costs. This is because the various alternatives should reflect resource cost to the economy as a whole at different future dates. Costing of the selected project may however be done in terms of financial costs, duly considering inflation during project implementation.

1.9.3.5 PROPOSED WASTEWATER PROJECT

a) *Details of the Project*

The project to be selected may consist those components of the least cost alternative of development sequence, which can be implemented during the next 3 to 4 years. Components of the selected project may be as follows:

- i) rehabilitation and de-bottlenecking of the existing facilities
- ii) construction of new facilities for improvement and expansion of existing systems
- iii) support activities like training, consumer education, public motivation etc.
- iv) equipment and other measures necessary for operation and maintenance of the existing and expanded systems
- v) consultancy services needed (if any) for conducting feasibility study, detailed engineering, construction supervision, socio-economic studies, support activities.

b) *Project Components*

All project components should be thoroughly described, duly supported by documents such as:

- i) location maps
- ii) technical information for each physical component and economic analysis where necessary
- iii) preliminary engineering designs and drawings in respect of each physical component, such as collection network, pumping stations, treatment plants, disposal system

c) *Implementation Schedule*

A realistic implementation schedule should be presented, taking into consideration time required for all further steps to be taken, such as conducting feasibility study, appraisal of the project, sanction to the project, fund mobilisation, implementation, trial and commissioning. In preparing this schedule due consideration should be given to all authorities/groups whose inputs and decisions can affect the project and its timing.

d) *Cost Estimates*

Cost estimates of each component of the project should be prepared and annual requirement of funds for each year should be worked out, taking into consideration the likely annual progress of each component. Due allowance should be made for physical contingencies and annual inflation. This exercise will result in arriving at total funds required annually for implementation of the project.

e) *Pre-feasibility Report*

The pre-feasibility report should bring out any major environmental and social impact the project is likely to cause and if these aspects will affect its feasibility. (Refer to 1.3.2)

f) *Institutional Responsibilities*

The pre-feasibility report should identify the various organisations/departments/agencies who would be responsible for further planning and project preparation, approval, sanction, funding, implementation, operation and maintenance of the project and indicate also the manpower needed to implement and later operate and maintain the project.

It should also discuss special problems likely to be encountered during operation and maintenance, in respect of availability of skilled and technical staff, funds, transport, chemicals, communication, power, spare parts etc. Quantitative estimates of all these resources should be made and included in the project report.

g) *Financial Aspects*

The capital cost of a project is a sum of all expenditure required to be incurred to complete design and detailed engineering of the project, construction of all its components including support activities and conducting special studies. After estimating component-wise costs, they may also be worked out on annual basis throughout the implementation period, taking into consideration construction schedule and allowances for physical contingencies and inflation. Basic item costs to be adopted should be of the current year. Annual cost should be suitably increased to cover escalation during the construction period. Total of such escalated annual costs determines the final cost estimate of the project. Financing plan for the project should then be prepared, identifying all the sources from which funds can be obtained and likely annual contribution from each source, until the project is completed. The possible sources of funds include:

- i) cash reserves available with the project authority
- ii) grant-in-aid from government
- iii) loans from government
- iv) loans from financing institutions like Life Insurance Corporation, Banks, HUDCO etc.
- v) open market borrowings
- vi) loans/grants from bilateral/international agencies
- vii) capital contribution from voluntary organisation or from consumers.

h) *Interest on Loan*

If the lending authority agrees, interest payable during implementation period can be capitalised and loan amount increased accordingly.

i) *Recurring Expenditure*

The next step is to prepare recurrent annual costs of the project for the next few years (say 10 years) covering operation and maintenance expenditure of the entire system (existing and proposed). This would include expenditure on staff, chemicals, energy, spare parts and other materials for system operation, transportation, up-keep of the systems and administration.

The annual financial burden imposed by a project comprises the annual recurring cost and payment towards loan and interest (debt-servicing) less the revenue derived from taxes, tariffs etc.

j) *Financing Plan*

Every State Government and the Government of India have schemes for financing water supply and waste water disposal schemes in the urban and rural areas and definite allocations are made for the national plan periods. It will be necessary at this stage to ascertain if and how much finance can be made available for the project under consideration and to estimate annual availability of funds for the project till its completion. This exercise has to be done in consultation with the concerned department of the Government and the lending institutions, who would see whether the project fits in the sector policies and strategies and can be brought in an annual planning and budgetary cycle taking into consideration the commitments already made in the sector and the overall financial resource position. The project may be finally sanctioned for implementation if the financing plan is firmed up.

1.9.3.6 CONCLUSIONS AND RECOMMENDATIONS

a) *Conclusions*

This section should present the essential findings and results of the pre-feasibility report. It should include a summary of:

- i) existing coverage
- ii) review of the need for the project
- iii) long-term development plans considered
- iv) the recommended project, its scope in terms of coverage and components
- v) Priorities concerning target-groups and areas to be served by the project
- vi) Capital costs and tentative financing plan
- vii) Annual recurring costs and debt servicing and projection of operating revenue
- viii) Urgency for implementation of the project
- ix) Limitation of the data/information used and assumption and acknowledgements made and need for indepth investigation, survey and revalidation of assumptions and judgements, while carrying out feasibility study.

The administrative difficulties likely to be met with and risks involved during implementation of the project should also be commented upon. These may pertain to boundary question for the project area, availability of land for constructing project facilities, coordination with the various agencies, acceptance of service by the beneficiaries, shortage of construction materials, implementation of support activities involving peoples' participation, supply of power, timely availability of funds for implementation of the project and problems of operation and maintenance of the facilities.

b) *Recommendations*

- i) This should include all actions required to be taken to complete project preparation and implementation, identifying the agencies responsible for taking these actions. A detailed time table for actions to be taken should be presented. If found necessary and feasible, taking up of works for rehabilitating and/or de-bottlenecking the existing system should be recommended as an immediate action. Such works may be identified and costed so that detailed proposals can be developed for implementation
- ii) It may also be indicated if the project authority can go ahead with taking up detailed investigations, data collection and operational studies, pending undertaking feasibility study formally
- iii) In respect of small and medium size projects, the pre-feasibility report can be considered sufficient for obtaining investment decision for the project if:
 - a) the results of the pre-feasibility study are based on adequate and reliable data/information
 - b) analysis of the data and situation is carried out fairly intensively
 - c) no major environmental and social problems are likely to crop up that might jeopardise project implementation and
 - d) no major technical and engineering problems are envisaged during construction and operation of the facilities
- iv) In that case the pre-feasibility study with suitable concluding report, should be processed for obtaining investment decision for the project. The feasibility study, can then be taken at the beginning of the implementation phase and if results of the study are noticed to be at variance with the earlier ones, suitable modification may be introduced during implementation
- v) In respect of major projects however and particularly those for which assistance from bilateral or international funding agencies is sought for, comprehensive feasibility study may have to be taken up before an investment decision can be taken.

1.9.4 Feasibility Report

Feasibility study examines the project selected in the pre-feasibility study as a short-term project, in much greater details, to see if it is feasible technically, financially, economically, socially, legally, environmentally and institutionally. Enough additional data/information may have to be collected to examine the above mentioned aspects, though the details necessary for construction of project components may be collected during execution of works.

It is a good practice to keep the authority responsible for taking investment decision, informed of the stage and salient features of the project. If there are good prospects of the project being funded immediately after the feasibility study is completed, detailed engineering of priority components may be planned simultaneously.

1.9.4.1 CONTENTS

The feasibility report may have the following sections:

Background

The Proposed Project

Institutional and Financial Aspects

Conclusions and Recommendations

1.9.4.2 BACKGROUND

This section describes the history of project preparation, how this report is related to other reports and studies carried out earlier, and in particular its setting in the context of a pre-feasibility report. It should also bring out if the data/information and assumptions made in the pre-feasibility report are valid and if not, changes in this respect should be highlighted. References to all previous reports and studies should be made.

In respect of the project area, need for a project and strategic plan for the same, only a brief summary of the information covered in prefeasibility report should be presented, highlighting such additional data/information if any collected for this report. The summary information should include planning period, project objectives, service coverage, service standards considered and selected for long-term planning and for the project, community preferences and affordability, quantification of future demands for services, alternative strategic plans, their screening and ranking, recommended strategic plan and cost of its implementation.

1.9.4.3 THE PROPOSED PROJECT

This section describes details of the project recommended for implementation. Information presented here is based on extensive analysis and preliminary engineering designs of all components of the project. The detailing of this section may be done in the following sub-sections

a) **Objectives**

Project objectives may be described in terms of general development objectives such as health improvements, ease in disposing wastewater, improved environmental conditions, human resources development, institutional improvements and also terms of specific objectives such as coverage of various target groups.

b) **Project Users**

Define number of people by location and institutions who will benefit and/or not benefit from the project area and reasons for the same, users involvement during preparation, implementation and operation of the project.

c) **Rehabilitation and De-bottlenecking of The Existing Wastewater Disposal System**

Rehabilitation, improvements and de-bottlenecking works, if necessary, should be planned for execution prior to that of the proposed project. If so these activities should be mentioned in the feasibility report if however these works are proposed as components of the proposed project, necessity of undertaking the rehabilitation/improvement/de-bottlenecking works should be explained.

d) *Project Description*

This may cover the following items in brief:

- i) definition of the project in the context of the recommended development alternative (strategic plan) and explanation for the priority of the project
- ii) brief description of each component of the project, with maps and drawings
- iii) functions, location, design criteria and capacity of each component
- iv) technical specification (dimension, material) and performance specifications
- v) stage of preparation of designs and drawings of each component
- vi) constructing in-house facilities
- vii) method of financing.

e) *Support Activities*

Need for and description of components such as staff training, improving billing and accounting, consumer education, health education, community involvement etc. and timing of undertaking these components and the agencies involved.

f) *Integration of the Proposed Project with the Existing and Future Systems*

Describe how the various components of the proposed project would be integrated with the existing and future works.

g) *Agencies Involved in Project Implementation and Relevant Aspects*

- i) designate the lead agency
- ii) identify other agencies including government agencies, who would be involved in project implementation, describing their role, such as granting administrative approval, technical sanction, approval to annual budget provision, sanction of loans, construction of facilities, procurement of materials and equipment etc.
- iii) outline arrangements to coordinate the working of all agencies
- iv) designate the operating agency and its role during implementation stage
- v) role of consultants if necessary, scope of their work, and terms of reference
- vi) regulations and procedures for procuring key materials and equipment, power, and transport problems if any
- vii) estimate number and type of workers and their availability
- viii) procedures for fixing agencies for works and supplies and the normal time it takes to award contracts
- ix) list of imported materials, if required, procedure to be followed for importing them and estimation of delivery period

- x) outline any legislative and administrative approvals required to implement the project, such as those pertaining to environmental clearance, prescribed effluent standards, acquisition of lands, permission to construct across, along roads and railways, high-tension power lines, in forest area and defence or other such restricted areas
- xi) comment on the capabilities of contractors and quality of material and equipment available indigenously.

h) *Cost Estimates*

- i) Outline basic assumptions made for unit prices, physical contingencies, price contingencies and escalation
- ii) summary of estimated cost of each component for each year till its completion and work out total annual costs to know annual cash flow requirements
- iii) estimate foreign exchange cost if required to be incurred
- iv) work out per capita cost of the project on the basis of design population, cost per unit of wastewater disposed and compare these with norms, if any, laid down by government or with those for similar projects.

i) *Implementation Schedule*

Prepare a detailed and realistic implementation schedule for all project components, taking into consideration stage of preparation of detailed design and drawings, additional field investigations required if any, time required for preparing tender documents, notice period, processing of tenders, award of works/supply contract, actual construction period, period required for procurement of material and equipment, testing, trials of individual components and system and commissioning of the facilities etc.

If consultant's services are required, the period required for completion of their work should also be estimated.

A detailed PERT/CPM network showing implementation schedule for the whole project, as well as those for each component should be prepared, showing linkages and inter-dependence of various activities.

Implementation schedule should also be prepared for support-activities such as training, consumers' education etc., and their linkages with completion of physical components and commissioning of the project should be established.

j) *Operation and Maintenance of the Project*

Estimate annual operating costs considering staff, chemicals, energy, transport, routine maintenance of civil works, maintenance of electrical/ mechanical equipment, including normal cost of replacement of parts and supervision charges. Annual cost estimates should be prepared for a period of 10 years from the probable year of commissioning the project, taking into consideration expected coverage and escalation.

Procedure for monitoring and evaluating the project performance with reference to project objectives should be indicated.

1.9.4.4 INSTITUTIONAL AND FINANCIAL ASPECTS

a) *Institutional Aspects*

It is necessary to examine capabilities of the organisations who would be entrusted with the responsibility of implementing the project and of operating the same after it is commissioned. The designated organisation(s) must fulfil the requirements in respect of organisational structure, personnel, financial, health and management procedures, so that effective and efficient performance is expected. This can be done by describing the following aspects:

- i) history of the organisation, its functions, duties and powers, legal basis, organisational chart, (present and proposed), relationship between different functional groups of the organisation and with its regional offices, its relation with government agencies and other organisations involved in sector development
- ii) public relations in general and consumer relations in particular, extension services available to sell new services, facilities for conducting consumer education programme and settling complaints
- iii) systems for budgeting for capital and recurring expenditure and revenue, accounting of expenditure and revenue, internal and external audit arrangements, inventory management
- iv) present positions and actual staff, comments on number and quality of staff in each category, ratio of staff proposed for maintenance and operation of the project to the population served, salary ranges of the staff and their comparison with those of other public sector employees
- v) staff requirement (category wise) for operating the project immediately after commissioning, future requirements, policies regarding staff training, facilities available for training
- vi) actual tariffs for the last 5 years, present tariff, tariff proposed after the project is commissioned, its structures, internal and external subsidies, procedure required to be followed to adopt new tariff, expected tariff and revenues in future years, proposal to meet shortage in revenue accruals
- vii) prepare annual financial statements (income statements, balance sheets and cash flows) for the project operating agency for five years after the project is commissioned, explain all basic assumptions for the financial forecast and the terms and conditions of tapping financial sources, demonstrate ability to cover all operating and maintenance expenditure and loan repayment, workout rate of return on net fixed assets and the internal financial rate of return of the project.

b) *Financing Plan*

Identify all sources of funds for implementation of the project, indicating year-by-year requirements from these sources, to meet expenditure as planned for completing the project as per schedule, state how interest during construction will be paid, or whether it will be capitalised and provided for in the loan, explain the procedures involved in obtaining funds from the various sources.

1.9.4.5 CONCLUSIONS AND RECOMMENDATIONS

This section should discuss justification of the project, in terms of its objectives, cost-effectiveness, affordability, willingness of the beneficiaries to accept the services and effect of not proceeding with the project.

Issues which are likely to adversely affect project implementation and operation should be outlined and ways of tackling the same should be suggested. Effect of changes in the assumptions made for developing the project on project implementation period, benefits, tariff, costs and demand etc. should be mentioned.

Definite recommendations should be made regarding time-bound actions to be taken by the various agencies, including advance action which may be taken by the lead agency pending approval and financing of the project.

CHAPTER 2

MANAGEMENT, ADMINISTRATION, LEGAL AND FINANCIAL ASPECTS

2.1 MANAGEMENT

In India, wastewater disposal systems are usually managed by local bodies. In a few specific cases these are managed by State Government Departments/Statutory Boards set up by State Governments. This service facility falls under the water supply and sanitation sector. The development of the sector is assisted at three levels.

2.1.1 Government of India (G.O.I) Level

Broad policies on sector development of Water Supply and Sanitation in urban and rural areas are formulated and circulated to State Governments and Union Territories as guide lines. Technical manuals are drafted and published for use by the Water and Wastewater authorities. General progress in providing these services in the urban and rural areas is monitored. External aid is also procured through the G.O.I. for major projects fulfilling certain norms. Apart from offering specific inservice training programmes for the employees of wastewater authorities in the States, financial assistance for specific inservice training programmes of the States is also offered. Assistance from financial institutions and other bodies like HUDCO, LIC etc., are available.

2.1.2 State Government Level

The State Governments offer to assist the local bodies in planning and implementation of wastewater disposal schemes of individual or a group of local bodies. Financial assistance is also given for these schemes in the form of Grant-In-Aid and loan etc. for capital investment. In special circumstances the State Governments assist the local bodies in operating and maintaining their wastewater disposal schemes through their own departments or through the statutory boards. Trained Engineers and skilled workmen are sometimes deputed to local bodies on request, to plan, implement and operate the systems. The State Governments monitor general progress of schemes of local bodies in respect of planning, implementation, operation and maintenance.

2.1.3 Local Body Level

It is obligatory responsibility of every local body (Municipality, village panchayat etc.) to collect, transport and properly dispose wastewater produced in the area under their respective jurisdictions. Depending upon financial status of each local body, the State/Central Governments come to the help of these local bodies to meet a part/whole of their capital investment cost on schemes in the form of Grant-In-Aid and/or loan. The expenditure on annual operation and maintenance of these schemes has however to be met by the local body out of its own revenue to be generated from taxes. As per the respective acts of local bodies, they have been empowered to levy and recover tax from the community to whom wastewater disposal facility is provided by the local body.

2.2 COMMON ASPECTS OF MANAGEMENT

The aspects considered in this chapter refer to management of wastewater disposal systems. There are five important aspects of management that could be considered namely (i) General Administration (ii) Personnel Administration, (iii) Inventory Control, (iv) Financial Control and (v) Public Relation. For proper maintenance of data, review, follow up and decision making, software programmes developed by the Central Public Health Environmental Engineering Organisation (CPHEEO) under Management Information System as well as by other agencies can be profitably used.

The system has to work as a unit management organisation.

The management in general should aim at the following achievement:

- a) Proper collection of wastewater discharged by the community
- b) Adequate treatment of wastewater to achieve the desired (prescribed) effluent standards
- c) Safe & efficient operations and as far as possible self supporting
- d) Sound financial management.

An efficient and effective management of wastewater disposal systems is most essential for their proper functioning.

2.2.1 General Administration

This could be sub-divided into two categories viz.(a) Supervisory and (b) Operational. The operational level is to be subordinate to supervisory level.

The supervisory administration is expected to control all the functions of management. Wastewater disposal works is an Engineering service. Hence it is a general practice to set up an Engineering Supervisory Organisation on the considerations of annual work load and expenditure to be handled by the organisation. These units are an Engineering Division Unit and an Engineering Sub-Division Unit. These Engineering Units would be administratively controlled by the local bodies of the town or village and their Committees.

2.2.1.1 SUPERVISORY STAFF

The duties and responsibilities of the supervisory units could be listed as under.

- a) To supervise and manage the wastewater disposal systems
- b) To develop annual operation and maintenance (A.O.M.) programme and the budget
- c) To implement A.O.M.programme using appropriate planning and scheduling techniques
- d) To keep accounts, records of the materials and tools, work performance and money spent on work establishment
- e) Periodically (say monthly/quarterly) inform the owner about the status of O.& M. programme and budget
- f) Prepare special reports as required to ensure economical and efficient use of resources
- g) Schedule, assign and monitor work being done by personnel in the organisation
- h) Purchase equipment, tools and supplies required to carry out the programme of the system
- i) Provide inservice training.

In addition to the above they should also look into the following aspects:

- a) That there are adequate maintenance facilities
- b) That the operations are smooth
- c) That the maintenance is efficient and economical
- d) That the administration is efficient and responsive (task assigned to the manager)
- e) That the equipment and supplies are controlled properly
- f) That good public relations are established
- g) That appropriate plans for future expansions are drafted.

Some other additional tasks that the supervisory units may handle could be briefly stated as under:

- a) The entire work of the organisation could be grouped into logical tasks or functions. Each function may be assigned to a group of workers
- b) Wherever found necessary and in the interest of work, powers could be delegated to subordinates
- c) The organisation could be flexible in order to enable it to respond to changing work load and work conditions
- d) Organisation manual and charts could be developed containing (i) Role of organisation, (ii) Job descriptions, (iii) Statements etc.
- e) O. & M. schedules could be prepared assigning works to individuals
- f) Works could be checked to see that these are being done as required/expected
- g) O. & M. manual could be developed to include (i) Description of system (ii) System operation (iii) Special items to be considered (iv) Lubrication and Maintenance (v) Repairs etc.
- h) Office operations include answering telephone calls, handling correspondence, records, typing letters/ statements, standardising work forms for transmission of information etc.
- i) Number and nature of complaints received
- j) Compilation of statistical information and producing necessary reports
- k) Documentation of how specific problems in implementation and O & M were overcome and dissemination of the same to other agencies.

2.2.1.2 OPERATING STAFF

The establishment required at operating level of a wastewater disposal system is determined on the basis of physical work output to be expected from each individual. The requirements are expected to vary according to individual circumstances, geographical locations and the like.

For optimum output from each of the operating staff certain modern business principles could be introduced such as:

- a) Unity of Command - Each worker should report to only one person incharge. One person incharge may not have more than 8 to 10 persons for direct control
- b) Each worker must have a clear understanding as to the expectations of the job from him by the supervisory units
- c) The worker should be given the relevant extract of the operating manual
- d) Regular work forms should be maintained by each worker and submitted to controlling person incharge
- e) Service records of each worker should be kept upto date by supervisory section and all dues paid to him on time
- f) All possible service facilities should be provided to the operating staff so that they can devote their full attention to work entrusted to them
- g) Personal grievances of workers should be attended to promptly.

2.2.2 Personnel Administration

The personnel administration can be classified into four categories namely:

- a) Describing and classifying work by developing job descriptions, establishing qualifications and goals for each position and developing wage and salary structure
- b) Recruiting and selecting employees by evaluation
- c) Evaluating the work of the employee by a system of evaluation norms such as confidential reports etc. The tasks should be identified and achievements mentioned against each task. General assessment made on these basis and report prepared. The evaluation may inter alia refer to (i) Knowledge and skill (ii) Punctuality (iii) Quality of work (iv) Dependability (v) Initiative and (vi) Tolerance of criticism
- d) Inservice training of employee (described separately hereafter).

2.2.3 Inventory Control

Inventory control is the process of managing supplies required for day to day management of wastewater works. It involves (a) deciding what supplies to stock (b) keeping a record of supplies and their locations and (c) accounting for all receipts and issues of supplies.

Many of the failures in the system require spare parts or supplies available instantly to put the system back in working order. These supplies have got to be ready at hand any time the failure occurs for repairs to be carried out. Materials of stock would pertain to items which have frequent usage and items of emergency repairs.

Inventory control cards are vital documents to serve the purpose of accountability and stock demand by reflecting usage pattern. They enable stock control and record purchasing information.

Inventory control would include tools required for O. & M. of the system, although new purchases for these may not be as frequent as for stock materials for repairs and replacement. Requirements have to be checked at intervals.

2.2.4 Financial Control

2.2.4.1 ACCOUNTING

Accounting is the process of recording and summarising business transactions that affect the financial status of the organisation of the wastewater disposal system. It is an important tool for monitoring revenues and expenditure activities and for interpreting the financial results of the organisation.

Accounting system would involve the following functions:

- a) A basic chart of accounts for the organisation
- b) Accounting reports such as income and expenditure statements, balance sheets and cash flow statements, debt servicing etc.
- c) Annual O. & M. budget
- d) A frequent review, say quarterly, of income analysis is desirable.

It would be desirable to keep financial records of the system on commercial lines to include:

- a) Updated valuation of the system
- b) Depreciation
- c) Operating expenses
- d) Investments in new capital improvements
- e) Long term debts, their servicing
- f) Appropriate schedules of taxes.

2.2.4.2 BUDGETING

Budgeting is the art of interpreting the goal of O. & M. Organisation in meaningful monetary terms. It should be used to control the financial activities of the organisation.

2.2.5 Public Relations

The object of public relations is to develop

- a) Satisfaction of the community served
- b) Opportunity for the community to know how works are planned, executed and managed
- c) Frequent dialogue between the community, owner and management
- d) Art of keeping owners informed about day to day working of the system, shortfalls if any and assistance required
- e) Objective interpretation of articles in the news papers about O. & M. situation, deficiencies, deviations etc., based on facts and figures.

Sufficient publicity needs to be given to the work being done by the management, difficulties experienced and cooperation required from public to make good the deficiencies, if any. Information could be given in newspapers. Appropriate talks could be given on T.V., A.I.R.etc., All criticism in the press about O.& M. of the system could be promptly attended to and appropriate replies published, preferably in the same newspapers in which criticism appeared.

In addition to the above activities publicity of O.& M. work is automatically enhanced if,

- a) every employee of the management who makes public contacts adopts a helpful and courteous attitude towards consumers and public
- b) Personal attention is paid to complaints and problems and these are dealt with promptly with courtesy and commonsense
- c) Community is encouraged to visit wastewater disposal works which should be kept clean, tidy and in good repairs
- d) Good relations are established with the media by providing fullest possible information on the system
- e) Contacts are established with benevolent, social, health and educational bodies
- f) Pamphlets on the wastewater disposal works are periodically published and distributed.

2.3 OTHER ASPECTS OF MANAGEMENT

2.3.1 Inservice Training

The object of well founded short term in-service training for the employees of wastewater disposal undertaking is

- i) To improve group level operational efficiency
- ii) To acquaint the group with the new developments
- iii) To develop amongst the members of the group a better understanding of human relations and concept of their individual responsibility to the community
- iv) To bring about an increased community appreciation in the operation of wastewater disposal works

The training could include

- a) Orientation courses to describe duties and responsibilities of individuals in the organisation
- b) Providing an employee with a hand book
- c) On the job training to work with an experienced employee for some time
- d) Work shops, short courses and seminars on concerned subjects.

The subjects to be included in the training could be

- a) How to perform a number of specific jobs well

- b) Lectures on practical aspects of subjects covered under wastewater disposal work including O & M
- c) Laboratory control tests
- d) Physical, chemical and bacteriological examination of sewage and interpretation of results
- e) Disinfection
- f) Design of component works of scheme
- g) Supervisory control
- h) Systems management and administration
- i) Accounting, budgeting and financial management.

2.3.2 Long Term Planning

One of the important functions of a wastewater disposal system management is to develop technical and financial plans for future expansion. For this purpose, the management should review periodically, present adequacy and future requirements. Some of the aspects to be reviewed could be:

- a) Analyse the ability of the system to cater, without causing problems to the needs of the community
- b) Forecast future requirements, determine the areas and the population to be covered and the likely future contribution
- c) Co-ordinate construction and financing

It is much better to keep up and improve the system through small construction programmes undertaken yearly than to allow deficiencies to accumulate. The yearly improvement should be planned to fit in with the prospective objectives and requirements

- d) The planning for future expansions require knowledge of original designs and basis for present system
- e) Local bodies may solicit assistance from external agencies such as Governments, Boards, Academic Institutions and Consultants for development of future plans and implementation programmes as required.

2.4 LEGAL ASPECTS

Municipal wastewaters contain organic/inorganic and other toxic matter which are injurious to the general health of man apart from being of immense nuisance value. It is therefore obligatory that the wastewater is properly treated and safely disposed off.

2.4.1 Municipal Bylaws

Most municipal bylaws provide for the owner of any property to dispose off his wastewater in a proper manner without causing any nuisance to others. Wherever municipal sewers exist within some specified distance, it is obligatory that the wastewater of the property is discharged into it. The bylaws provide for action against defaulting owners. However in the case of areas not originally served with

sewerage facilities, the owners may have to be persuaded to avail of the facilities provided to dispose off their wastewaters and in some cases it may even become necessary for the local body to show some incentive like loan/subsidy for getting the works necessary to dispose the wastewater into such municipal sewers.

2.4.2 Prevention of Pollution

The early law regulating pollution was enforced almost entirely through the process of individual suits for what was termed a private nuisance. The concept of public nuisance has also been used to some degree to control pollution. A public nuisance is an act which causes inconvenience or damage to the public as distinguished from one or a few individuals and includes any interference with the public health, safety, or inconvenience. A public nuisance is subject to abatement at the behest of state officials. It may also constitute a crime.

In our country until recently the pollution was regulated through state factory acts and rules and also by some sections (section 28) of the Indian Easement Act. As the scope of these acts is limited in its extent and does not provide much guidance in respect of water pollution prevention, the Union Government enacted the Water (Prevention and Control of Pollution) Act, in 1974, which is applicable to all Union Territories and has been adopted by all the States, by resolution passed in that behalf under clause (i) of Article 252 of the Constitution. Under the provision of this Act, no discharge of wastewater can be made in the environment without obtaining consent from the State Pollution Control Board (from the Central Pollution Control Board, in respect of Union Territories). A consent prescribes the volume and quality of wastewater in terms of concentration of various pollutants which can be permitted for discharge in the environment.

In 1986, the Union Government enacted the Environment (Protection) Act 1986, for protection and improvement of environment and the prevention of hazards to human beings, other living creatures, plants and property. The Act empowers the Union Government to make rules providing standards in excess of which environmental pollutants shall not be discharged or emitted in the environment and to take direct action against defaulters.

2.5 FINANCIAL ASPECTS

2.5.1 General

The aim of any wastewater disposal project should be to provide the lowest cost wastewater collection, transportation, treatment and disposal facility to the community. This demands, in addition to the knowledge of wastewater works planning, design, construction and administration, a sound understanding of the elements of financial policy, viz.,

- i) The equitable spreading of the cost of wastewater disposal system by means of appropriate scales of taxes/cess and
- ii) The economic aspects of development and execution of the schemes, the methods of providing the capital needed to finance such schemes and the manner of providing for the redemption of such capital outlay.

Apart from the above, financing in the wastewater disposal sector requires consideration of expanding requirements due to increase in population, changes in living habits and also increasing discharge of wastewater due to emphasis on industrialisation.

2.5.2 Scope

The salient features of wastewater disposal financing are:

- a) methods of raising capital for the installation of the system and provision for redemption of loans where needed
- b) methods of raising revenue to meet the annual expenses of wastewater disposal including the determination of tax/cess as well as their collection/recovery
- c) the formation and use of reserve and contingency funds
- d) accounting in connection with income and expenditure
- e) wages, store and cost accounting
- f) financial organisation and control such as ordering of goods, budgeting, insurance etc.

2.5.3 Sources for Raising Capital

The various sources available for raising capital are:

- i) accumulated funds with the local body
- ii) grant from government, donations from individuals/agencies
- iii) internal borrowing, which means investing the surplus funds of the authority itself from its various accumulations which is the cheapest source as the rate of interest would be the lowest and
- iv) external borrowings from
 - a) Government with stipulated terms of repayment
 - b) Open market borrowings through bonds
 - c) National Financing institutions like Life Insurance Corporation, HUDCO, Nationalised Banks etc.
 - d) Direct beneficiaries
 - e) Bilateral assistance
 - f) International agencies such as the World Bank, International Development Authority (IDA), Asian Development Bank.

2.5.4 Financial Appraisal

Financial appraisal of wastewater disposal scheme is necessary:

- i) to ensure that the project is financially viable - whether the project will meet all its financial obligations including Operation and Maintenance, debt servicing, whether there will be adequate working capital, whether the project along with any cross financing from water supply scheme can generate funds from internal resources to make the scheme self supporting

- ii) to adjust the level and structure of taxes/cess charged, when need arises
- iii) to ensure recovery of investment and operating costs from the project beneficiaries.

The finances of a project are closely reviewed through projections of the balance sheet, income/expenditure statement, and cash flow. Where financial accounts are inadequate a new accounting system has to be established.

2.5.5 Statutory Water and Sanitation Boards

Most of the local bodies at present face serious handicaps in the promotional stages of a project, in its prefinancing stage and in the fund raising stage as well. Saddled as they are with responsibilities beyond their capacity and circumscribed by limitation of finance and procedures, any attempts by them individually to raise loans in the open market to finance a local wastewater disposal project may not attract encouraging response. This problem may be solved by the creation of autonomous water and sanitation Boards.

These boards are devices by which State Government will be able to establish corporate public entities to construct, manage and operate water and sanitary services on a fully commercial basis in large metropolitan areas as well as in smaller urban communities. These Boards should be empowered and equipped to raise such capital from local resources and the open market borrowings to supplement the resources provided by the Government at the State and Central level. Such Boards may have the advantage of:

- i) an increased efficiency resulting from financial autonomy
- ii) improved ability to raise capital with confidence
- iii) affording better opportunities for small municipalities grouped together to finance and operate their schemes as a business proposition
- iv) the economies implicit in a common authority which may be made to serve several undertakings
- v) a better and fuller realisation of Taxes/Cess when this duty is divorced from local politics
- vi) the economies possible by pooling technical and administrative staff to serve a number of municipalities and
- vii) the opportunities for equalising the rates in every region.

A statutory Water and Sanitation Board may be set up at State level with regional boards if and to the extent necessary within the State, to provide water and sanitation services and to collect revenues to meet such services, to raise the capital needed to provide the facilities and to exercise all other corporate powers necessary to act on behalf of the local bodies within their jurisdiction. Normally, such boards would encompass all activities including production, conveyance and distribution of water within their statutory areas and also for the collection, treatment and disposal of sewage from that area as well as other sanitation services. It is, however, possible that some local bodies may prefer to purchase water in bulk from the statutory boards and arrange for the internal distribution themselves and may also prefer to have the statutory Board take over sewage in bulk from the local area and arrange for its treatment and disposal. This should be avoided as far possible as the supply and distribution of water as also collection and disposal of sewage are two interdependent functions and the divisions of such functions amongst two independent agencies might lead to inefficiency and avoidable difficulties for both parties. Any local body managing its systems satisfactorily need not necessarily come under such a Board.

CHAPTER 3

DESIGN OF SEWERS

3.1 INTRODUCTION

Sewerage systems may be classified as sanitary sewers designed to receive domestic sewage and industrial wastes excluding storm water, storm sewers designed to carry off storm water and ground water but excluding domestic sewage and industrial wastes and combined sewers designed to receive domestic sewage, industrial wastes and storm water. These systems may also be part storm sewers and part combined sewers.

The combined system of sewerage though may be economical initially, suffers from several disadvantages such as sluggish flow during non stormy days, leading to deposition of sewage solids causing foul odours and increased cost of eventual sewage treatment or pumping costs, associated with disposal of sewage. In view of this, the combined system is normally not recommended.

Anticipation of future growth in any community in terms of population or commercial and industrial expansion should be based on a long-range Master Plan, which shall form the basis for preparation of plan for providing the amenities including installation of sewers in the area to be served. A plan of this type will permit the orderly and timely expansion of the facilities on a sound technical and financial basis, without resorting to costly crash programmes. The provision for future should not however be much in excess of the actual discharge in the early years of its use to avoid deposition in sewers.

3.2 ESTIMATION OF SANITARY SEWAGE

Separate sanitary sewers are provided, primarily to carry the spent water of a community with some ground water and a fraction of storm run off and the community's industrial wastes to the point of treatment and disposal. The sewer capacity to be provided must be determined from an analysis of the present and probable quantities expected at the end of design period. The estimation of flow is based upon the contributory population and the per capita flow of sewage, both the factors being guided by the design period. The connection of roof, back yard, and foundation drains to the sanitary sewers should be avoided and hence shall not be considered for the estimation of sanitary sewage.

3.2.1 Design Period

The length of time upto which the capacity of a sewer will be adequate is referred to as the design period. In fixing a period of design, consideration must be given for the useful life of structures and equipment employed, taking into account obsolescence as well as wear and tear, the ease or difficulty of extending or increasing or addition of the works including a consideration of their location, design constraints, the anticipated rate of growth of the population with due regard to increase in industrial and commercial needs and the economic justification linked to the rate of interest and inflation.

Because the flow is largely a function of population served, population density and water consumption, lateral and sub-main sewers are usually designed for peak flows of the population at saturation density as set forth in the Master Plan. Trunk sewers, interceptors, and outfalls are difficult and uneconomical to be enlarged or duplicated and hence are designed for longer design periods. In the case of trunk sewers serving relatively undeveloped areas adjacent to metropolitan areas, it is advisable to construct initial facilities for more than a limited period. Nevertheless right of way for future larger size trunk sewers can be acquired or reserved. Thus, the population estimate is guided by the anticipated ultimate

growth rates of each community. These may differ in different zones of the same town. A design period of 30 years (excluding construction period) is recommended for all types of sewers.

3.2.2 Population Forecast

Methods of estimation of population for arriving at the design population have been discussed in 1.5. Where a Master Plan containing land use pattern and zoning regulations is available for the town, the anticipated population can be based on the ultimate densities and permitted floor space Index provided for in the Master Plan. In the absence of such information on population the following densities are suggested for adoption.

Size of town (Population)	Density of population per hectare.
Upto 5,000	75 - 150
5,000 to 20,000	150 - 250
20,000 to 50,000	250 - 300
50,000 to 1,00,000	300 - 350
Above 1,00,000	350 - 1000

In cities where Floor Space Index (FSI) or Floor Area Ratio (FAR) limits are fixed by the local authority this approach may be used for working out the population density. FSI or FAR is the ratio of total floor area (of all the floors) to the plot area. The densities of population on this concept may be worked out as in the following example:

Assume that a particular development plan rules provide for the following reservations for different land uses.

Roads	20%
Gardens	15%
Schools (including playgrounds)	5%
Markets	2%
Hospital and Dispensary	2%

Total	44%

Area available for Residential Development (100 - 44) = 56%

Actual total floor area = Area for residential development x FSI.

Assuming an FSI of 0.5 and floor area of 9 m²/person.

Number of persons or density = $\frac{0.56 \times 10,000 \times 0.5}{9}$ = 311 per hectare.

3.2.3 Tributary Area

The natural topography, layout of buildings, political boundaries, economic factors etc., determine the tributary area. For larger drainage areas, though it is desirable that the sewer capacities to be designed for the total tributary area, some time, political boundaries and legal restrictions prevent the sewers to be constructed beyond the limits of the local authority. However in designing sewers for larger areas, there is usually an economic advantage in providing adequate capacity initially for a certain period of time and adding additional sewers, when the pattern of growth becomes established. The need to finance projects within the available resources may necessitate the design to be restricted to political boundaries. The tributary area for any section under consideration has to be marked on a key plan and the area can be measured from the map.

3.2.4 Per capita Sewage Flow

The entire spent water of a community should normally contribute to the total flow in a sanitary sewer. However, the observed Dry Weather Flow quantities usually are slightly less than the per capita water consumption, since some water is lost in evaporation, seepage into ground, leakage etc. In arid regions, mean sewage flows may be as little as 40 percent of water consumption. In well developed areas, flows may be as high as 90% due to industrial wastes, changed water use habits etc. Generally 80% of the water supply may be expected to reach the sewers unless there is data available to the contrary. However, the sewers should be designed for a minimum waste water flow of 100 litres per capita per day. Industries and commercial buildings often use water other than the municipal supply and may discharge their liquid wastes into the sanitary sewers. Estimates of such flows have to be made separately. The details of requirements of water for Institutions and Industries is discussed in Chapter 2 of Manual on Water Supply and Treatment. Industrial wastes have to be treated to the standards prescribed by the regulatory authorities before being discharged into sewers. For some areas, it is safe to assume that the future density of population for design purpose to be equal to the saturation density. It is desirable that all sewers serving a small area be designed on the basis of saturation density.

Infiltration into sewer may occur through pipes, pipe joints and structures. The probable amount has to be evaluated carefully.

3.2.5 Flow Assumptions

The flow in sewers varies considerably from hour to hour and also seasonally, but for the purposes of hydraulic design it is the estimated peak flow that is adopted.

The peak factor or the ratio of maximum to average flows, depends upon contributory population and the following values are recommended.

Contributory population	Peak Factor
Upto 20,000	3.0
20,000 to 50,000	2.5
50,000 to 7,50,000	2.25
Above 7,50,000	2.00

The peak factors also depend upon the density of population, topography of the site, hours of water supply and therefore it is desirable to estimate the same in individual cases, if required. The minimum flow may vary from 1/3 to 1/2 of average flow.

3.2.6 Storm Runoff

Sanitary sewers are not expected to receive storm water. Strict inspection and vigilance and proper design and construction of sewers and manholes should eliminate this flow or bring it down to a very insignificant quantity.

3.2.7 Ground Water Infiltration

Estimate of flow in sanitary sewers may include certain flows due to infiltration of ground water through joints. The quantity will depend on workmanship in laying of sewers and level of the ground water table. Since sewers are designed for peak discharges, allowance for ground water infiltration for the worst condition in the area should be made. Suggested estimates for ground water infiltration for sewers laid below ground water table are as follows:

	Minimum	Maximum
liters/Ha.d	5,000	50,000
liters/Km.d	500	5,000
lpd/manhole	250	500

With improved standards of workmanship and quality and availability of various construction aids, these values should tend to the minimum, rather than the maximum. These values should not mean any relaxation on the water tightness test requirements in 7.1.5 (Hydraulic testing of pipe sewers).

3.3 ESTIMATION OF STORM RUNOFF

Storm runoff is that portion of the precipitation which drains over the ground surface. Estimation of such runoff reaching the storm sewers therefore is dependent on intensity and duration of precipitation, characteristics of the tributary area and the time required for such flow to reach the sewer. The storm water flow for this purpose may be determined by using the rational method, hydrograph method, rainfall-runoff correlation studies, digital computer models, inlet method or empirical formulae.

The empirical formulae that are available for estimating the storm water runoff can be used only when comparable conditions to those for which the equations were derived initially can be assured.

A rational approach, therefore, demands a study of the existing precipitation data of the area concerned to permit a suitable forecast. Storm sewers are not designed for the peak flow of rare occurrence such as once in 10 years or more but, it is necessary to provide sufficient capacity to avoid too frequent flooding of the drainage area. There may be some flooding when the precipitation exceeds the design value, which has to be permitted. The frequency of such permissible flooding may vary from place to place, depending on the importance of the area. Though such flooding causes inconvenience, it may have to be accepted once in a while considering the economy effected in storm drainage costs.

The maximum runoff, which has to be carried in a sewer section should be computed for a condition when the entire basin draining at that point becomes contributory to the flow and the time needed for this is known as the time of concentration (t_c) with reference to the concerned section. Thus, for

estimating the flow to be carried in the storm sewer, the intensity of rainfall which lasts for the period of time of concentration is the one to be considered contributing to the flow of storm water in the sewer. Of the different methods, the rational method is more commonly used.

3.3.1 Rational Method

3.3.1.1 RUNOFF - RAINFALL INTENSITY RELATIONSHIP

The entire precipitation over the drainage district does not reach the sewer. The characteristics of the drainage district, such as, imperviousness, topography including depressions and water pockets, shape of the drainage basin and duration of the precipitation determine the fraction of the total precipitation which will reach the sewer. This fraction known as the coefficient of runoff needs to be determined for each drainage district. The runoff reaching the sewer is given by the expression,

$$Q = 10 C i A \quad (3.1)$$

Where Q is the runoff in m³/hr;

'C' is the coefficient of runoff;

'i' is the intensity of rainfall in mm/hr and

'A' is the area of drainage district in hectares.

3.3.1.2 STORM FREQUENCY

The frequency of storm for which the sewers are to be designed depends on the importance of the area to be drained. Commercial and industrial areas have to be subjected to less frequent flooding. The suggested frequency of flooding in the different areas is as follows:

a) Residential areas

- | | | |
|-----|---|--------------|
| i) | Peripheral areas | twice a year |
| ii) | Central and comparatively high priced areas | once a year |

b) Commercial and high priced areas

once in 2 years

3.3.1.3 INTENSITY OF PRECIPITATION

The intensity of rainfall decreases with duration. Analysis of the observed data on intensity duration of rainfall of past records over a period of years in the area is necessary to arrive at a fair estimate of intensity-duration for given frequencies. The longer the record available, the more dependable is the forecast. In Indian conditions, intensity of rainfall adopted in design is usually in the range of 12mm/hr to 20mm/hr.

Table 3.1 gives the analysis of the frequency of storms of stated intensities and durations during 26 years for which rainfall data were available for a given town.

TABLE 3.1
ANALYSIS OF FREQUENCY OF STORMS

Duration in Minutes	Intensity mm/hr	30	35	40	45	50	60	75	100	125
		No of Storms of intensity or more for a period of 26 years								
5						100	40	18	10	2
10				90	72	41	25	10	5	1
15			61	75	45	20	12	5	1	
20		83	52	51	31	10	9	4	2	
30		73	40	22	10	8	4	2		
40		54	16	8	4	2	1			
50		14	8	4	3	1				
60		8	4	2	1					
90		4	2							

The stepped line indicates the location of the storm occurring once in 2 years, i.e. 13 times in 26 years. The time-intensity values for this frequency are obtained by interpolation and given in Table 3.2.

TABLE 3.2
TIME INTENSITY VALUES OF STORMS

i (mm/hr)	t (min)
30	51.67
35	43.75
40	36.48
45	28.57
50	18.50
60	14.62
75	8.12

The relationship may be expressed by a suitable mathematical formula, several forms of which are available. The following two equations are commonly used:

$$i) \quad i = \frac{a}{(t^n)} \quad (3.2)$$

$$ii) \quad i = \frac{a}{t + b} \quad (3.3)$$

Where,

i = intensity of rainfall (mm/hr)

t = duration of storm (minutes) and

a, b and n are constants.

The available data on i and t are plotted and the values of the intensity (i) can then be determined for any given time of concentration, (t_c).

3.3.1.4 TIME OF CONCENTRATION

It is the time required for the rain water to flow over the ground surface from the extreme point of the drainage basin and reach the point under consideration. Time of concentration (t_c) is equal to inlet time (t_i) plus the time of flow in the sewer (t_f). The inlet time is dependent on the distance of the farthest point in the drainage basin to the inlet manhole, the shape, characteristics and topography of the basin and may generally vary from 5 to 30 minutes. In highly developed sections, the inlet time may be as low as 3 minutes. The time of flow is determined by the length of the sewer and the velocity of flow in the sewer. It is to be computed for each length of sewer to be designed.

3.3.1.5 COEFFICIENT OF RUNOFF

The portion of rainfall which finds its way to the sewer, is dependent on the imperviousness and the shape of tributary area apart from the duration of storm.

a) *Imperviousness*

The percent imperviousness of the drainage area can be obtained from the records of a particular district. In the absence of such data, the following may serve as a guide;

Type of area	Percentage of Imperviousness
Commercial and Industrial area	70 to 90
Residential Area:	
i) High density	60 to 75
ii) Low density	35 to 60
Parks & undeveloped areas	10 to 20

The weighted average imperviousness of drainage basin for the flow concentrating at a point may be estimated as

$$I = \frac{A_1 I_1 + A_2 I_2 + \dots}{A_1 + A_2 + \dots} \quad (3.4)$$

Where.

- A_1, A_2 = drainage areas tributary to the section under consideration
 I_1, I_2 = imperviousness of the respective areas and
 I = weighted average imperviousness of the total drainage basin.

b) *Tributary Area*

For each length of storm sewer, the drainage area should be indicated clearly on the map and measured. The boundaries of each tributary are dependent on topography, land use, nature of development and shape of the drainage basins. The incremental area may be indicated separately on the compilation sheet and the total area computed.

c) *Duration of Storm*

Continuously long light rain saturates the soil and produces higher coefficient than that due to heavy but intermittent rain in the same area because of the lesser saturation in the latter case. Runoff from an area is significantly influenced by the saturation of the surface nearest the point of concentration, rather than the flow from the distant area. The runoff coefficient of a larger area has to be adjusted by dividing the area into zones of concentration and by suitably decreasing the coefficient with the distance of the zones.

d) *Computation of Runoff Coefficient*

The weighted average runoff coefficients for rectangular areas, of length four times the width as well as for sector shaped areas with varying percentages of impervious surface for different times of concentration are given in Table 3.3. Although these are applicable to particular shapes of areas, they also apply in a general way to the areas which are usually encountered in practice. Errors due to difference in shape of drainage are within the limits of accuracy of the rational method and of the assumptions on which it is based.

A typical example of the computation of storm runoff is given in Appendix 3.1.

TABLE 3.3
RUN OFF COEFFICIENTS

Duration, t, minutes	10	20	30	45	60	75	90	100	120	135	150	180
Weighted Average Coefficients												
1) Sector concentrating in stated time												
(a) Impervious	.525	.588	.642	.700	.740	.771	.795	.813	.828	.840	.850	.865
(b) 60% Impervious	.365	.427	.477	.531	.569	.598	.622	.641	.656	.670	.682	.701
(c) 40% Impervious	.285	.346	.395	.446	.482	.512	.535	.554	.571	.585	.597	.618
(d) Pervious	.125	.185	.230	.277	.312	.330	.362	.382	.399	.414	.429	.454
2) Rectangle (length = 4 x width) concentrating in stated time												
(a) Impervious	.550	.648	.711	.768	.808	.837	.856	.869	.879	.887	.892	.903
(b) 50% Impervious	.350	.442	.499	.551	.590	.618	.639	.657	.671	.683	.694	.713
(c) 30% Impervious	.269	.360	.414	.464	.502	.530	.552	.572	.588	.601	.614	.636
(d) Pervious	.149	.236	.287	.334	.371	.398	.422	.445	.463	.479	.495	.522

3.4 HYDRAULICS OF SEWERS

3.4.1 Type of Flow

Flow in sewers is said to be steady, if the rate of discharge at a point in a conduit remains constant with time, and if the discharge varies with time, it is unsteady. If the velocity and depth of flow are the same from point to point along the conduit, the steady open channel flow is said to be uniform flow, and non uniform if either the velocity, depth or both are changing. In laminar flow the fluid moves along in smooth layers, while in turbulent flow the fluid moves in irregular paths.

The hydraulic analysis of sewers is simplified by assuming steady flow conditions. In large storm channels, or where surge or water hammer is predominant, as in pumping mains, the flow can be unsteady. Most sewers have turbulent flows with stream lines following the boundaries.

A properly functioning sewer has to carry the peak flow for which it is designed and transport suspended solids in such a manner that deposits in a sewer are kept to a minimum. The design for waste water collection system presumes flow to be steady and uniform. The unsteady and non-uniform waste water flow characteristics are accounted in the design by proper sizing of manholes.

3.4.2 Flow - Friction Formulae

The available head in waste water lines is utilised in overcoming surface resistance and, in small part, in attaining kinetic energy for flow.

Estimated design flows depend to a large extent on the assumptions, the accuracy of which is variable. In spite of this, care is required to select an accurate friction flow formula as to avoid compounding errors. However, the design practice is to use the Mannings formula for open channel flow and the Hazen Williams and Darcy-Weisbach formulae for closed conduit or pressure flow.

3.4.2.1 MANNINGS FORMULA

$$V = \left[\frac{1}{n} \right] \times \left[R^{2/3} S^{1/2} \right] \quad (3.5)$$

For circular conduits

$$V = \left(\frac{1}{n} \right) (3.968 \times 10^{-3}) D^{2/3} S^{1/2} \quad (3.6)$$

$$\text{and } Q = \left(\frac{1}{n} \right) (3.118 \times 10^{-6}) D^{2/3} S^{1/2} \quad (3.7)$$

Where

Q	=	discharge in lps
S	=	slope of hydraulic gradient
D	=	internal dia of pipe line in mm
R	=	hydraulic radius in m
V	=	velocity in mps
n	=	Manning's coefficient of roughness

A chart for Manning's formula is given in Appendix 3.2.

The values of Manning's coefficient for different pipe materials are given in Table 3.4.

A reduction in the value of 'n' has been reported with increase in diameter.

3.4.2.2 DARCY WEISBACH FORMULA

Darcy and Weisbach suggested the first dimension - less equation for pipe flow problems as,

$$S = \frac{H}{L} = \frac{fV^2}{2gD} \quad (3.8)$$

Where

H	=	head loss due to friction over length L in meters
f	=	dimension-less friction factor
V	=	Velocity in m/s
g	=	acceleration due to gravity in m/sec ²
D	=	Internal diameter in meters

This formula is not normally used in the design of sewers. Reference may be made to IS 2951 for calculation of head loss due to friction according to Darcy Weisbach formula.

TABLE 3.4
COEFFICIENT OF ROUGHNESS FOR USE IN MANNING'S FORMULA

Type of Material	Condition	n
Salt glazed stone ware pipe	(a) Good	0.012
	(b) Fair	0.015
Cement Concrete Pipes. (with collar joints)	(a) Good	0.013
	(b) Fair	0.015
Spun concrete pipes (RCC & PSC) with Socket Spigot Joints (Design Value)		0.011
Masonry	(a) Neat cement plaster	0.018
	(b) Sand and cement plaster	0.015
	(c) Concrete, steel troweled	0.014
	(d) Concrete, wood troweled	0.015
	(e) Brick in good condition	0.015
	(f) Brick in rough condition	0.017
	(g) Masonry in bad condition	0.020
Stone-work	(a) Smooth, dressed ashlar	0.015
	(b) Rubble set in cement	0.017
	(c) Fine, well packed gravel	0.020
Earth	(a) Regular surface in good condition	0.020
	(b) In ordinary condition	0.025
	(c) With stones and weeds	0.030
	(d) In poor condition	0.035
	(e) Partially obstructed with debris or weeds	0.050
Steel	(a) Welded	0.013
	(b) Riveted	0.017
	(c) Slightly tuberculated	0.020
	(d) With spun cement mortar lining	0.011
Cast Iron	(a) Unlined	0.013
	(b) With spun cement mortar lining	0.011
Asbestos Cement		0.011
Plastic (smooth)		0.011

3.4.2.3 HAZEN-WILLIAMS FORMULA

is expressed as follows:

$$V = 0.849 C R^{0.63} S^{0.54} \quad (3.9)$$

for circular conduits, the expression becomes

$$V = 4.567 \times 10^{-3} C D^{0.63} S^{0.54} \quad (3.10)$$

and

$$Q = 1.292 \times 10^{-5} C D^{2.63} S^{0.54} \quad (3.11)$$

Where,

- Q = discharge in cum per hour
- D = internal diameter of pipe in mm
- V = Velocity in mps
- R = hydraulic radius in m
- S = slope of hydraulic gradient and
- C = Hazen - Williams coefficient

A chart for the Hazen-Williams formula is given in Appendix 3.3.

The values of Hazen-Williams coefficient C for new conduit materials and the values to be adopted for design purposes are furnished in Table 3.5.

3.4.2.4 FRICTION COEFFICIENTS

Friction coefficients for various materials and conditions have been determined based on laboratory and field experiments. Factors which affect the choice of a friction coefficient are conduit material, Reynolds number, size and shape of conduit and depth of flow. Errors inherent in the use of Manning's formula and Hazen-Williams formula are

- i) Both formulae are dimensionally inconsistent
- ii) The friction coefficients used in the formulae namely Hazen-Williams C and Manning's 'n' are usually considered independent of pipe diameter, velocity of flow and viscosity, whereas to be representative of friction conditions these coefficients must depend on relative roughness of pipe and Reynolds Number.

3.4.2.5 MODIFIED HAZEN-WILLIAMS FORMULA

The Modified Hazen-Williams formula has been derived from Darcy Weisbach and Colebrook-White equations which overcomes the limitations of Hazen-Williams formula.

The modified Hazen-Williams formula is derived as

$$V = 143.534 C_R R^{0.6575} (S)^{0.5525} \quad (3.12)$$

in which

V	=	Velocity of flow in mps
C_R	=	Pipe roughness coefficient (1 for smooth pipes, <1 for rough pipes)
R	=	hydraulic radius in m
S	=	friction slope

For more detailed information reference may be made to Chapter 6 of Manual on Water Supply and Treatment.

TABLE 3.5
HAZEN - WILLIAMS COEFFICIENTS

Sl. No.	Conduit Material	Recommended values for	
		New Pipes	Design
1.	Concrete (RCC & PSC) with socket & spigot joints	150	120*
2.	Asbestos cement	150	120*
3.	Plastic pipes	150	120*
4.	Cast iron	130	100
5.	Steel, welded joints	140	100
6.	Steel, welded joints lined with cement or bituminous enamel	150	120*

These pipe materials are less likely to lose their carrying capacity with age, and hence Higher values may be adopted for design purpose if reliable field data is available to justify such revision.

3.4.2.6 DEPTH OF FLOW

From considerations of ventilation in waste water flow, sewers should not be designed to run full. All sewers are to be designed to flow 0.8 full at ultimate peak flow. Table 3.6 shows the hydraulic properties of circular sections for Manning's Formula.

Reference may be made to Fig.3.1 for hydraulic elements of circular sewers and to Fig.3.2 for hydraulic elements of circular sewers that possess equal self cleansing velocity at all depths.

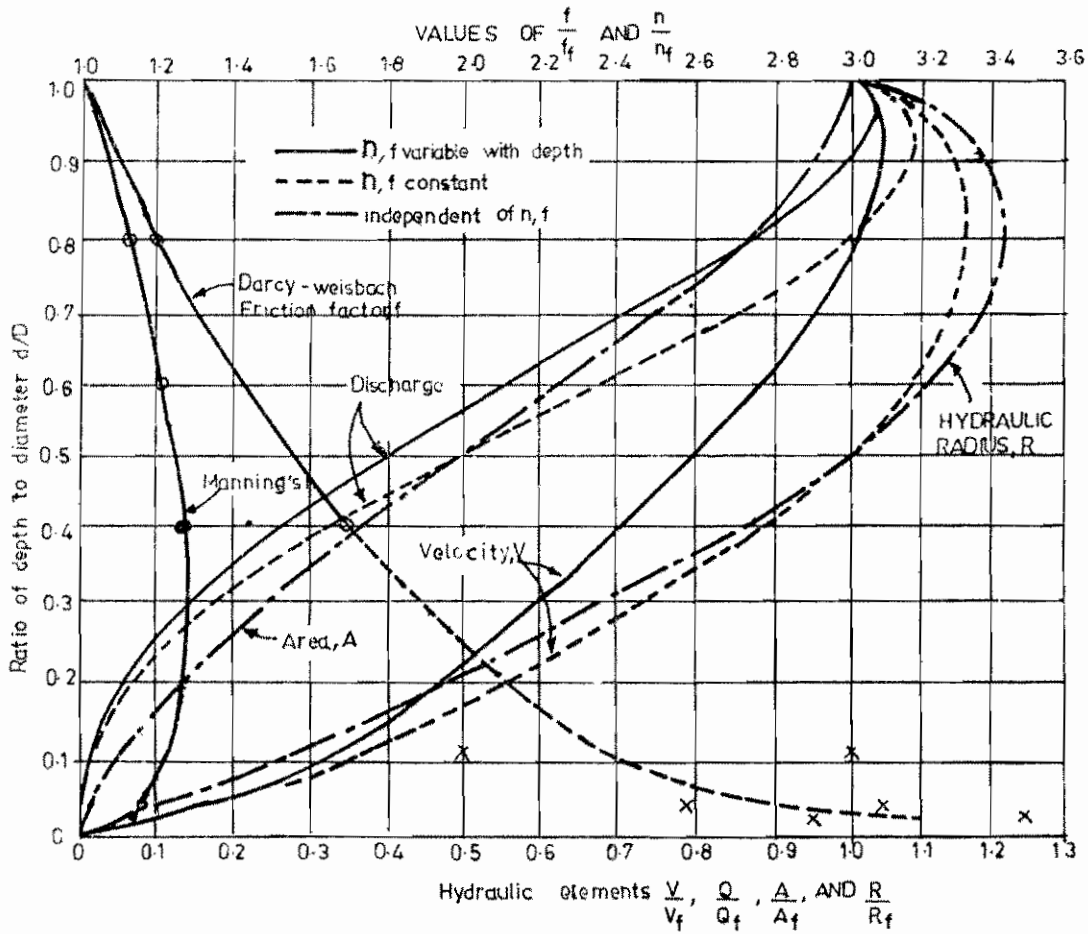

FIG. 3.1 • HYDRAULIC-ELEMENTS GRAPH FOR CIRCULAR SEWERS.

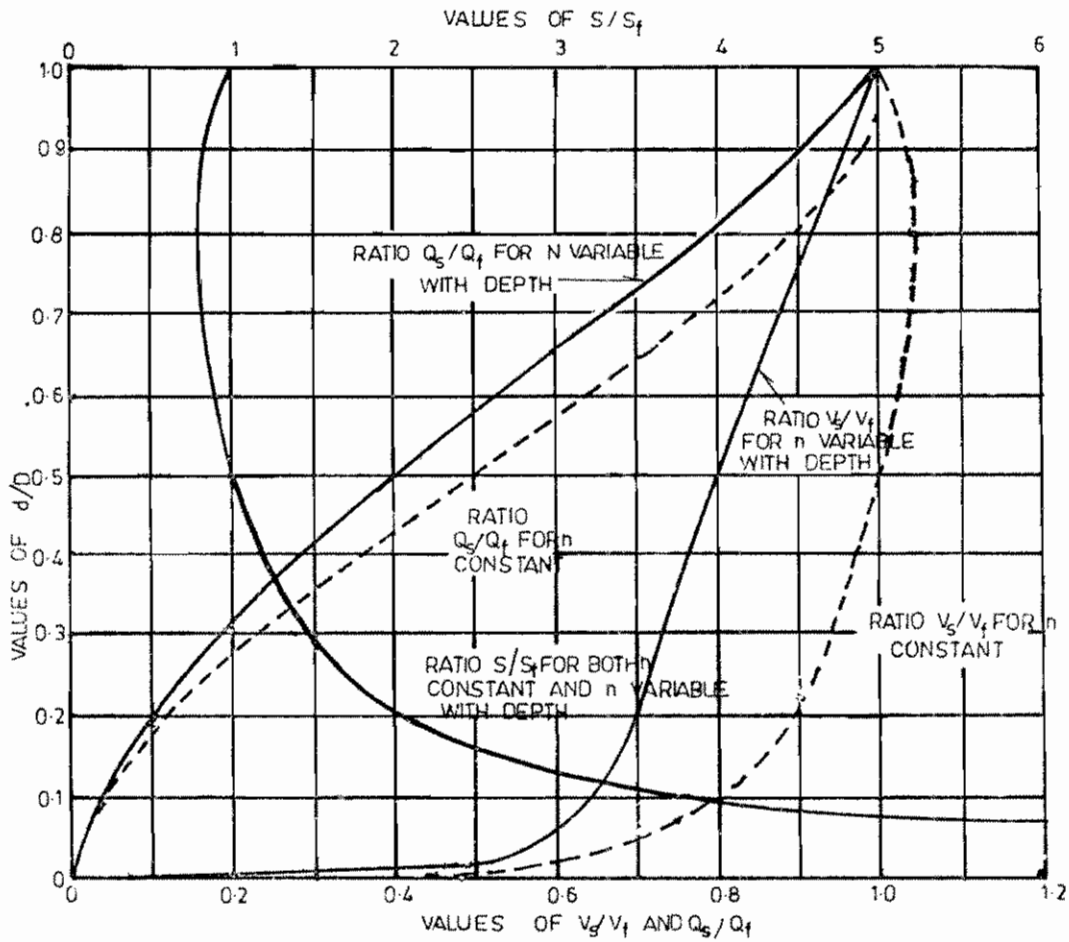

FIG. 3.2: HYDRAULIC ELEMENTS OF CIRCULAR SEWERS THAT POSSESS EQUAL SELF-CLEANSING PROPERTIES AT ALL DEPTHS.

3.4.2.7 FORMULA FOR SELF CLEANSING VELOCITY

From finding of Shields, Camp derived the formula

$$V = (1/n)R^{1.6} \{ K_s (S_s - 1) d_p \}^{1/2} \quad (3.13)$$

In which S_s is specific gravity of particle, d_p is particle size and K_s is a dimensionless constant with a value of about 0.04 to start motion of granular particles and about 0.8 for adequate self cleansing of sewers.

The Shields formula indicates that velocity required to transport material in sewers is only slightly dependent on conduit shape and depth of flow but mainly dependent on the particle size and specific weight. A velocity of 0.60 mps would be required to transport sand particle of 0.09mm with a specific gravity of 2.65. Hence a minimum velocity of 0.8 mps at design peakflow and 0.6 mps for present peak flow is recommended in the sanitary sewers.

TABLE 3.6
HYDRAULIC PROPERTIES OF CIRCULAR SECTIONS FOR MANNING'S FORMULA

d/D	Constant (n)			Variable (n)		
	v/V	q/Q	n_d/n	v/V	q/Q	
1.0	1.000	1.000	1.00	1.000	1.000	
0.9	1.124	1.066	1.07	1.056	1.020	
0.8	1.140	0.968	1.14	1.003	0.890	
0.7	1.120	0.838	1.18	0.952	0.712	
0.6	1.072	0.671	1.21	0.890	0.557	
0.5	1.000	0.500	1.24	0.810	0.405	
0.4	0.902	0.337	1.27	0.713	0.266	
0.3	0.776	0.196	1.28	0.605	0.153	
0.2	0.615	0.088	1.27	0.486	0.070	
0.1	0.401	0.021	1.22	0.329	0.017	

Where,

D = Full Depth of flow (internal dia)
V = Velocity at full depth
n = Manning's coefficient at full depth
Q = Discharge at full depth

d = Actual depth of flow
v = Velocity at depth 'd'
 n_d = Manning's coefficient at depth 'd'
q = Discharge at depth 'd'

3.4.3 Velocities

The flow in sewers varies widely from hour to hour and also seasonally, but for purpose of hydraulic design, it is estimated peakflow that is adopted. However it is to be ensured that a minimum velocity is maintained in the sewers even during minimum flow conditions. At the same time the velocity should not be excessive to cause erosion.

3.4.3.1 VELOCITY AT MINIMUM FLOW

It is necessary to size the sewer to have adequate capacity for the peakflow to be achieved at the end of design periods, so as to avoid steeper gradients and deeper excavations. It is desirable to design sewers for higher velocities wherever possible. This is done on the assumption that although silting might occur at minimum flow, the silt would be flushed out during the peak flows. However the problem of silting may have to be faced in the early years particularly for smaller sewers which are designed to flow part full at the end of design period, where the depth of flow during early years is only a small fraction of the full depth. Similarly upper reaches of laterals pose a problem as they flow only partly full even at the ultimate design flow, because of necessity of adopting the prescribed minimum size of sewer. In such situations flushing arrangements may be provided in the initial years.

In the design of sanitary sewer an attempt should be made to obtain adequate scouring velocities at the average or at least at the maximum flow at the beginning of the design period. It has been shown that for sewers running partially full, for a given flow and slope, velocity is little influenced by pipe diameter. It is, therefore, recommended that for present peak flows upto 30 lps, the slopes given in Table 3.7 may be adopted, which would ensure a minimum velocity of 0.60 mps in the early years.

**TABLE 3.7
RECOMMENDED SLOPES FOR MINIMUM VELOCITY**

<u>Present peak flow in lps</u>	<u>Slope per 1,000</u>
2	6.0
3	4.0
5	3.1
10	2.0
15	1.3
20	1.2
30	1.0

After arriving at slopes for present peak flows, the pipe size should be decided on the basis of ultimate design peak flow and the permissible depth of flow. The minimum diameter for a public sewer may be 150mm. However, the minimum size in hilly areas, where extreme slopes are prevalent, may be 100mm.

3.4.3.2 EROSION AND MAXIMUM VELOCITY

Erosion of sewers is caused by sand and other gritty material in the sewer and also by excessive velocity. Velocity in a sewer is recommended not to exceed 3.0 mps.

3.4.4 Sewer Transitions

3.4.4.1 NON UNIFORM FLOW

For uniform flow in sewers the slope of the energy and hydraulic grade lines are same as the slope of the invert and the depth of flow will adjust to produce a velocity in proportion with the frictional losses.

In non uniform flow, the energy and hydraulic grade lines are not parallel. Flow in sewers is not uniform in all reaches. There will be regions of uniform and non uniform flow. For longer sewers, it is a good practice to plot the hydraulic profile for various reaches. Profile calculations have to begin at a point

where depth and velocity are known. In many cases the hydraulic profile can be calculated from a control section where total energy above the invert is a minimum for a given discharge or the rate of flow is maximum for a given total energy. This is known as critical flow or flow at critical depth, where Froude's number F is equal to unity. Froude's Number is defined as

$$F = \frac{V}{\sqrt{gd_m}} \quad (3.14)$$

where d_m = hydraulic mean depth

If $F < 1$, the flow is subcritical

and if $F > 1$, the flow is supercritical

For arriving at the profile, the analysis begins at control point i.e. where $F = 1$ and proceeds upstream when upstream flow is subcritical and proceeds downstream when downstream flow is supercritical.

3.4.4.2 SPECIFIC ENERGY

For a given section and discharge the specific energy head is a function of depth of flow only. If the depth of flow is plotted against specific energy, a specific energy curve is obtained, (fig.3.3) which shows that for all flows except critical flow there are two possible alternate stages or depths at which flow may occur for any value of specific energy head and discharge, depending on channel slope, friction and location of control section.

Where a flow passes from a subcritical stage on a gentle sloping channel to a supercritical stage in a steeply sloping channel it must pass a control section. The control section is located in the vicinity of break in grade and critical flow occurs there. Fig.3.4 shows non uniform flow hydraulic profile. The upstream slope which is less than the critical slope is called subcritical slope or a mild slope. The downstream slope which is greater than the critical slope is called a supercritical slope or a steep slope.

3.4.4.3 HYDRAULIC JUMP

Hydraulic Jump is a phenomenon where a flow in a channel abruptly changes from supercritical flow at a shallow depth to subcritical flow at a greater depth. For a flow from a steep to a mild slope, the hydraulic jump occurs which results in a loss of head. The hydraulic jump may be evolved as a device for dissipation of energy such as where a steep sewer enters a large sewer at a junction. The most important consideration is the location of jump. Fig.3.5 depicts the energy conditions to show that the jump must take place on the mild slope. If the required down stream total energy necessary to transport the flow is greater than that which would result if the jump occurred on the mild slope, the jump must take place on the steep slope. In either case there is a backwater or draw down curve from the jump to the break in grade. The loss of head in hydraulic jump may be calculated by the principle,

$$\frac{d_2}{d_1} = \frac{1}{2} \sqrt{(1 + 8F_1^2) - 1} \quad (3.15)$$

$$\Delta H = H_1 - H_2 = \frac{(d_2 - d_1)^3}{4d_1 d_2}$$

In which d_1 and d_2 are depths before and after jump, F_1 is Froude's Number

upstream of flow,

ΔH is loss of head, H_1 , H_2 are specific heads of flow before and after jump.

3.4.4.4 BACK WATER CURVES

Back water or draw down curves occur from abrupt changes in sewer slopes, when there is a tree fall or an obstruction to the flow. It is possible in some cases to make a saving in cost by reducing the size of conduit or lowering the roof, thus possibly avoiding over head structures. Hence it is desirable to know the amount by which the depth is increased at various points along the curve and the distance upstream upto which the back water curve extends. Most frequently encountered curves for mild and steep slopes are given in Fig.3.6.

The following formula is used for stepwise calculations of the reach of conduit between cross sections of given depth.

$$\Delta L = \frac{(d - h_v)}{S_e - S_a} \quad (3.16)$$

ΔL = Portion of reach of conduit

d = depth of flow

h_v = velocity head

S_e = average slope of energy grade line

S_a = slope of invert and

$\Delta(d-h_v)$ is the change of specific energy between cross sections.

An illustrative example for backwater curve is given in Appendix 3.4.

3.4.4.5 SEWER TRANSITIONS

Where conduits of different characteristics are connected, sewer transitions occur. The difference may be flow, area, shape, grade, alignment and conduit material, with a combination of one or all characteristics. Transitions may be in the normal cases streamlined and gradual and can occur suddenly in limiting cases. Head lost in a transition is a function of velocity head and hence assumes importance in the flat terrain. Deposits also impose significant losses. For design purposes it is assumed that energy losses and changes in depth, velocity and invert elevation occur at the centre of transition and after wards these changes are distributed through out the length of transition. The energy head, piezometric head (depth) and invert as elevation are noted and working from Energy grade line, the required invert drop or rise is determined. However if the calculations indicate a rise in invert it is ignored since such a rise will create a damming effect leading to deposition of solids.

For open channel transition in subcritical flow the loss of energy is expressed as

$$\text{Head Loss} = K (V^2 / 2g) \quad (3.17)$$

Where $(V^2/2g)$ is change of velocity head before and after transition, $K = 0.1$ for contractions and 0.2 for expansions.

In transitions for supercritical flow, additional factors must be considered, since standing waves of considerable magnitude may occur or in long transitions air entrainment may cause backing of flow. Allowance for the head loss that occurs at these transitions has to be made in the design.

Manholes should be located at all such transitions and a drop should be provided where the sewer is intercepted at a higher elevation for streamlining the flow, taking care of the headloss and also to help in maintenance. The vertical drop may be provided only when the difference between the elevations is more than 60 cm, below which it can be avoided by adjusting the slope in the channel and in the manhole connecting the two inverts. The following invert drops are recommended:

- | | | |
|-----|------------------------------|-----------------------------|
| (a) | For sewers less than 400 mm. | Half the difference in dia. |
| (b) | 400 mm. to 900 mm. | 2/3 the difference in dia. |
| (c) | Above 900 mm. | 4/5 the difference in dia. |

Transition from larger to smaller diameters should not be made. The crowns of sewers are always kept continuous. In no case, the hydraulic flowline in the large sewers should be higher than the incoming one. To avoid backing up, the crown of the outgoing sewer should not be higher than the crown of incoming sewer.

3.4.4.6 BENDS

The head loss in bends is expressed by

$$h_b = k_c V^2 / 2g \quad (3.18)$$

Where k_b is a bend coefficient which is a function of the ratio of radius of curvature of the bend to the width of conduit, deflection angle, cross section of flow, Reynolds Number and relative roughness.

K_b is approximately equal to 0.4 for 90 degrees and 0.32 for 45 degrees and can be linearly proportioned for other deflection angles.

3.4.4.7 JUNCTION

A junction occurs where one or more branch sewers enter a main sewer. The hydraulic design is in effect, the design of two or more transitions, one for each path of flow. Apart from hydraulic considerations, well rounded junctions are required to prevent deposition. Because of difficulty in theoretically calculating the hydraulic losses at junctions, some general conditions may be checked to ensure the proper design of junctions. If available energy at junctions is small gently sloping transitions may be used. The angle of entry may be 30 degrees or 45 degrees with reference to axis of main sewer, whenever ratio of branch sewer diameter to main sewer diameter is one half or less. Junctions are sized so that the velocities in the merging streams are approximately equal at maximum flow. If considerable energy is available in long sewers at a junction, a series of steps may be provided in the branch to produce a cascade or it may be designed as a hydraulic jump to dissipate energy in the branch before entering main sewer. Vertical pipe drops are used frequently at junctions for which main sewer lies well below the branch sewers, particularly if the ratio of branch sewer diameter and main sewer diameter is small. These pipe drops are designed with an entrance angle of 30 degrees with the main sewer.

3.4.4.8 VERTICAL DROPS AND OTHER ENERGY DISSIPATORS

In developed areas, it may be sometimes necessary and economical to take the Trunk Sewers deep enough like tunnels. In such cases the interceptors and laterals may be dropped vertically through shafts to the deep trunk sewers or Tunnels. Hydraulic problems encountered with such deep vertical drops may be difficult to solve and may be some times solved by model studies. Vertical drops must be designed so as to avoid entrapment of air. Air entrapped in a shaft can result in surges which may reduce the capacity of intake. Entrapped air may not be able to flow along the sewer and escape through another ventilation shaft. Air problems can be minimised by designing a shaft with an open vortex in the middle for full depth of drop. To accomplish this, the flow is to be inducted tangentially into inlet chamber at the head of the shaft. If the vertical drop is likely to cause excessive turbulence, it may be desirable to terminate the drop in the branch to dampen the flow before it enters the main flow.

Another type of vertical drop incorporates a water cushion to absorb the impact of a falling jet. Water cushion required has been found to be equal to $h^{1/2} d^{1/3}$ in which h is the height of fall and d is depth of the crest.

Special chutes or steeply inclined sewers are constructed instead of vertical drops. All drops cause release of gasses and maintenance problems and hence should be avoided where possible.

3.4.5 Inverted Siphon

When a sewer line dips below the hydraulic grade line, it is called an inverted siphon. The purpose is to carry the sewer under the obstruction and regain as much elevation as possible after the obstruction is passed. They should be resorted to only where other means of passing the obstruction are not feasible as they require considerable attention in maintenance. As the siphons are depressed below the hydraulic grade line, maintenance of self cleansing velocity at all flows is very important. Two considerations which govern the profile of a siphon are provision for hydraulic losses and ease of cleaning. It is necessary to ascertain the minimum flows and the peak flows for design. To ensure self-cleansing velocities for the wide variations in flows, generally, two or more pipes not less than 200mm dia are provided in parallel so that

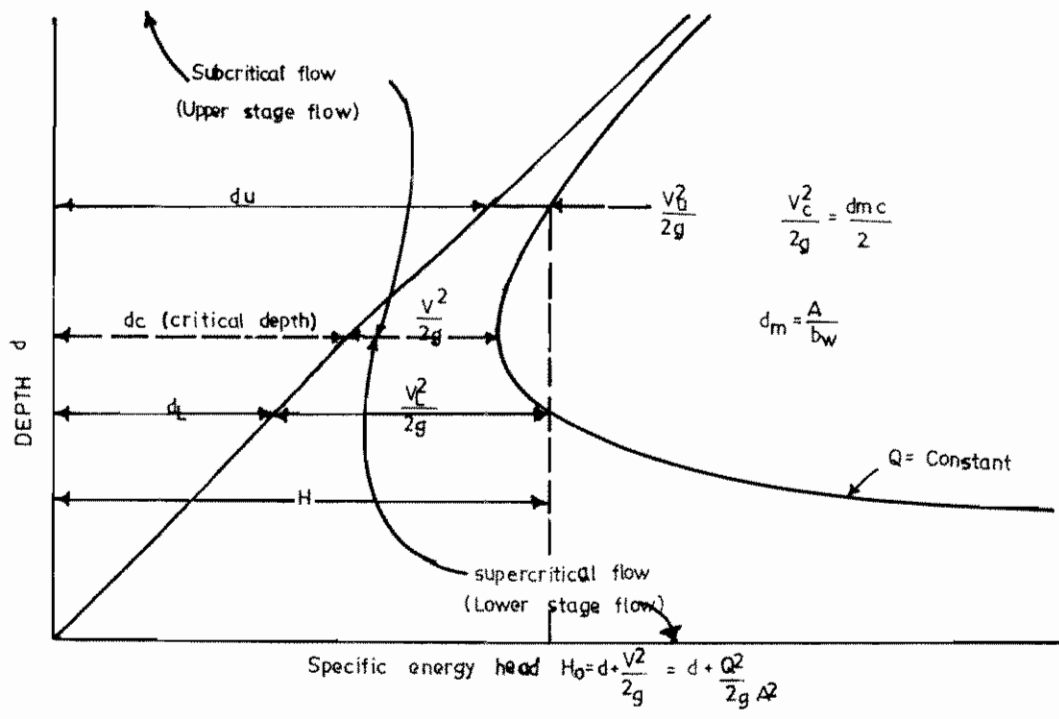

FIG. 3.3: SPECIFIC ENERGY CURVE

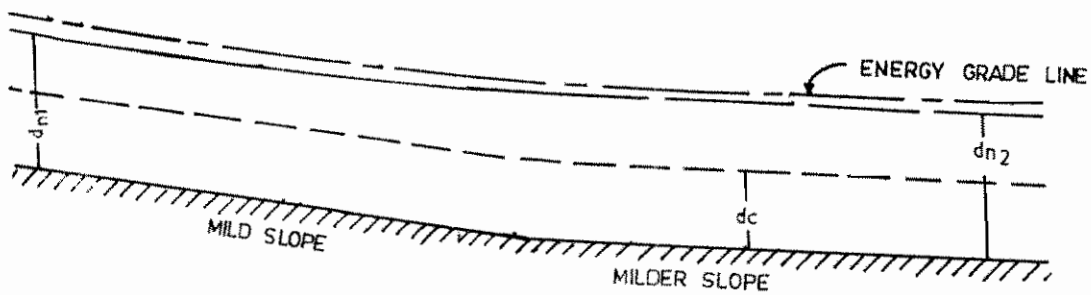
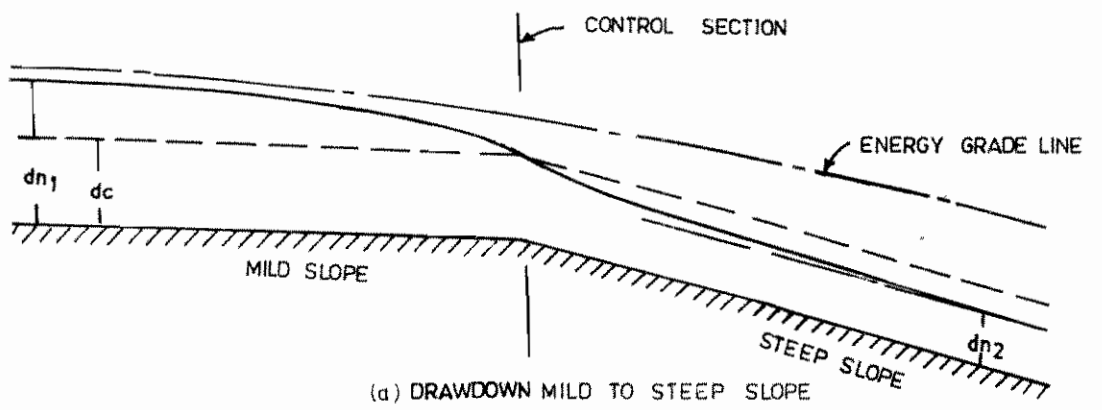

FIG. 3.4: NON-UNIFORM FLOW HYDRAULIC PROFILES

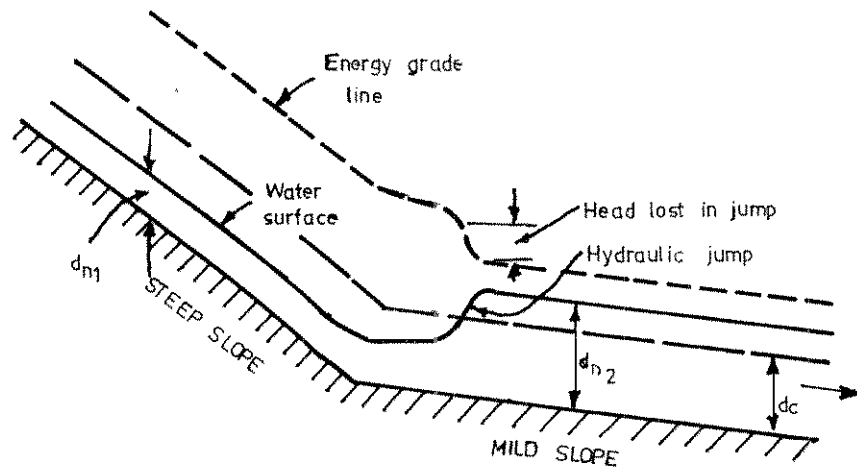

FIG. 3.5: HYDRAULIC JUMP PROFILE

upto the average flows. the pipe is used and when the flow exceeds the average, the balance flow is taken by the second and subsequent pipes. Siphons may need cleaning oftener than gravity sewers and hence should not have any sharp bends either horizontal or vertical. Only smooth curves of adequate radius should be used. The design criteria for inverted siphons are given in IS:411 Part-III. Some of the important criteria are given below.

3.4.5.1 HYDRAULIC CALCULATIONS

As the inverted siphon is a pipe under pressure, a difference in the water levels at the inlet and outlet is the head under which the siphon operates. This head should be sufficient to cover the entry, exit and friction losses in pipes. The friction loss through the barrel will be determined by the design velocity. The Hazen-Williams formula, or the Modified Hazen- Williams Formula can be used for calculation of head loss.

3.4.5.2 VELOCITY

It is necessary to have a self-cleansing velocity of 1.0 mps for the minimum flow to avoid deposition in the line

3.4.5.3 SIZE AND ARRANGEMENT OF PIPES

In the multiple pipe siphon, the inlet should be such that the pipes come into action successively as the flow increases. This may be achieved by providing lateral weirs with heights kept in accordance with the depth of flow at which one or more siphon pipes function. Fig. 3.7 gives the general arrangement for a three-way siphon. In the two-pipe siphon, the first pipe should take 1.25 to 1.5 times the average flow and second should take the balance of the flow.

3.4.5.4 INLET AND OUTLET CHAMBERS

The design of inlet and outlet chambers should allow sufficient room for entry for cleaning and maintenance of siphons. The outlet chambers should be so designed as to prevent the backflow of sewage into pipes which are not being used at the time of minimum flow.

3.4.5.5 GENERAL REQUIREMENTS

Provision should be made for isolating the individual pipes as well as the siphon to facilitate cleaning. This can be done by providing suitable penstocks or stop boards at the inlet and outlet of each pipe and by providing stopvalve at its lower point if it is accessible. A manhole at each end of the siphon should be provided with clearance for rodding. The rise, out of the siphon for small pipes should be on a moderate slope so that sand and other deposits may be moved out of the siphon. The rising leg should not be so steep as to make it difficult to remove heavy solids by cleaning tools that operate on hydraulic principle. Further there should be no change of diameter in the barrel since this would hamper cleaning operation. It is desirable to provide a coarse screen to prevent the entry of rags etc., into the siphon.

Proper bypass arrangements should be provided from the inlet chamber and if required special arrangements should be made for pumping the sewage to the lower reach of sewer line. Alternatively a vacuum pump may be provided at the outlet to overcome maintenance problems arising out of clogging and silting of syphons. If it is possible a blow off may be installed at the low point to facilitate emergency maintenance operations.

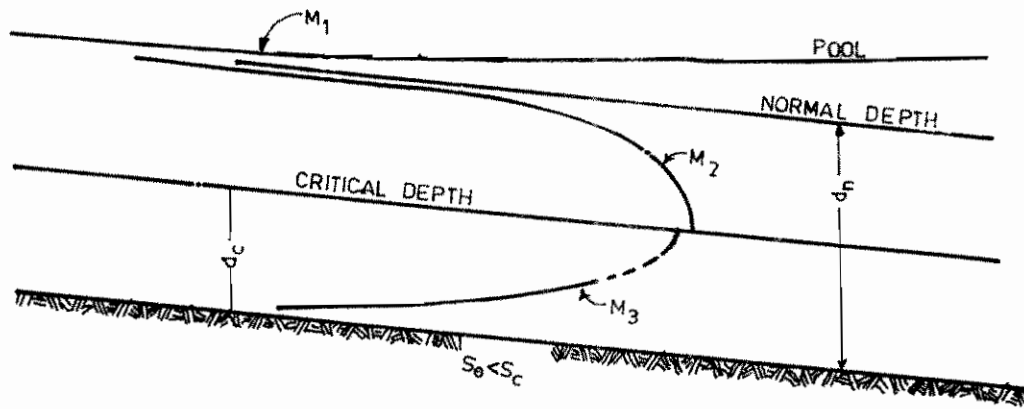

- M₁- BACKWATER FROM RESERVOIR OR FROM CHANNEL OF Milder Slope ($d > d_n$)
- M₂-DRAWDOWN, AS FROM CHANGE OF CHANNEL OF MILD Slope TO STEEP Slope ($d_n > d > d_c$)
- M₃-FLOW UNDER GATE ON MILD Slope OR UPSTREAM PROFILE BEFORE HYDRAULIC JUMP ON MILD Slope ($d < d_c$)

(a) MILD Slope ($d_n > d_c$)

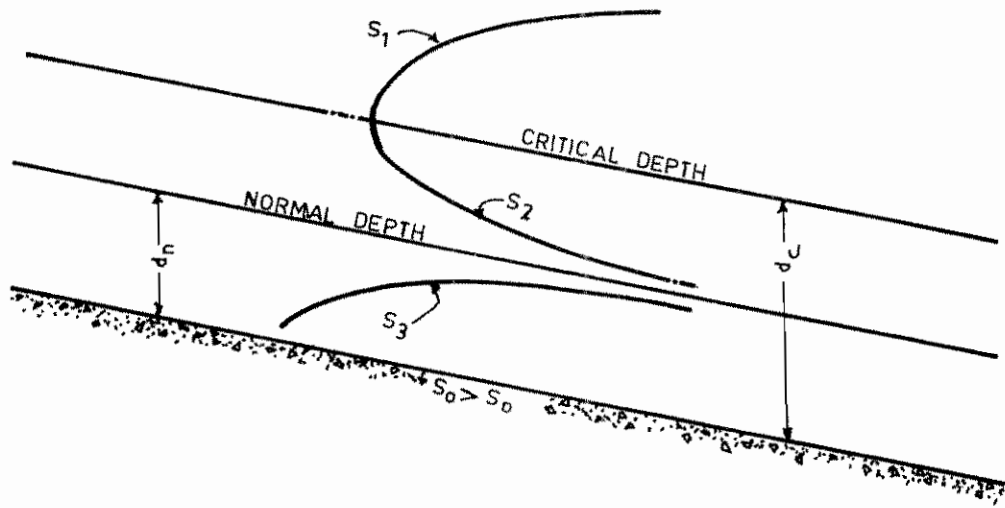

- S₁-DOWNSTREAM PROFILE AFTER HYDRAULIC JUMP ON STEEP Slope ($d < d_c$)
- S₂-DRAWDOWN, AS FROM MILD TO STEEP Slope OR STEEP Slope TO STEEPER Slope ($d_c > d > d_n$)
- S₃-FLOW UNDER GATE ON STEEP Slope, OR CHANGE FROM STEEP Slope TO LESS STEEP Slope ($d < d_n$)

(b) STEEP Slope ($d_n < d_c$)

FIG.3.6: OPEN-CHANNEL FLOW CLASSIFICATIONS.

Positive pressure develops in the atmosphere upstream of a siphon because of the downstream movement of air induced by the sewage flow. This air tends to exhaust from the manhole at the siphon inlet. The exiting air can cause serious odour problems. Conversely air is drawn in at the siphon outlet. Attempts can be made to close the inlet structure tightly so that the air gets out at manholes or vents upstream. However this causes depletion of oxygen in the sewer and leads to sulphide generation. To avoid this, sufficient ventilation arrangements have to be provided.

3.4.6 Relief Sewers

An overloaded existing sewer may require relief, with the relief sewer constructed parallel to the existing line. Relief sewers are also called supplementary sewers. In the design it must be decided whether (a) the proposed sewer is to share all the rates of flow with the existing sewer or (b) it is to take all flows in excess of predetermined quantity or (c) it is to divert a predetermined flow from the upper end of the system.

The topography and available head may dictate which alternative is selected. If flows are to be divided according to a ratio, the inlet structure to the relief sewer must be designed to divide the flow. If the relief sewer is to take all flows in excess of a predetermined quantity, the excess flow may be discharged through a weir to the relief sewer. If the flow is to be diverted in the upper reaches of a system, the entire flow at the point of diversion may be sent to the relief sewer or the flow may be divided in a diversion structure.

A decision as to the method of relief to be chosen depends on available velocities. Self cleansing velocities have to be maintained in either or both sewers even after diversion of flows. Otherwise nuisance conditions may result. If the relief sewer is designed to take flows in excess of a fixed quantity the relief sewer itself will stand idle much of the time and deposits may occur. In some cases it might be better to make the new sewer large enough to carry the total flow and to abandon the old one.

3.4.7 Force Mains

Sewage may have to be carried to higher elevations through force mains. The size of the main should be determined by taking into account the initial cost of pipeline and cost of operation of pumping for different sizes. Velocities may be upto 3m/s. Hazen - Williams formula is generally used for computing the frictional losses (Eq.3.9). The size of force main can also be determined by using Modified Hazen - Williams formula mentioned in 3.4.2.5.

Losses in valves, fittings, etc., are dependent upon the velocity head $v^2/2g$. Loss in bends and elbows depend upon the ratio of absolute friction factor to dia of pipe, besides velocity head. Loss due to sudden enlargement depends upon the the ratio of diameters. The losses in bends, enlargements and tapers are given in Manual on Water Supply and Treatment. In the actual design of the force mains, it may not be necessary to compute the losses individually but the same may be assumed arbitrarily as 10% of the total frictional losses depending upon the number of bends, tapers and other fittings. However, for shorter mains with a large number of bends etc., the actual loss may be computed and expressed as equivalent length. For economic design of force main a reference may be made to Chapter 6 of Manual of Water Supply and Treatment. Each individual case needs to be studied from various aspects such as operation of pumps within the specified limits, availability of land required for duplicating the main in future etc.

3.4.8 Sulphide Generation

Sewage when out of contact with air results in sulphide production. At pH 5 it is nearly all of H_2S and at pH 9 it is HS^- (Hydrogen Sulphide ion). Sulphide buildup in force mains can be prevented by

injection of compressed air into pump discharge, at the rate of 10 L/min for each cm of pipe diameter. Sulphide generation usually occurs in force mains. It can also occur in partfull sewers if the rate of oxygen transfer at the surface is insufficient to keep with the demand. Deep flow is more conducive to sulphide generation, and hence sulphide generation may be minimised by designing sewers with shallow depth of flow if economical. Velocities of about 1m/s may be required to prevent sulphide build up.

3.5 DESIGN OF SEWER SYSTEMS

3.5.1 Introduction

Sewers are meant to transport storm water or waste water from one location to another location by gravity and therefore have to be laid deep enough to receive all the flows. Sewers must resist erosion and corrosion and its structural strength must be sufficient to carry backfill, impact, and live loads satisfactorily. The size and slope of sewer must be adequate for the flow to be carried and sufficient to prevent deposition of solids. Ease and economy of maintenance, safety to the personnel and the public during its life as well as during construction also must be considered.

In the design of a sewer system the decisions are location, size, slope, and depth of sewer and sewer material and other appurtenances to be added such as manholes, junctions and other structures to minimize turbulence and save head loss and prevent deposits. The aim of design is not only to make the sewer system functional, but also build the system at lowest cost ensuring durability over the life of the system.

3.5.2 Available Head

Generally the total available energy is utilized to maintain proper flow velocities in the sewers with minimum head loss. However in hilly terrain excess energy may have to be dissipated using special devices. Hence the sewer system design is limited on onehand by hydraulic losses which must be within the available Head and on the other to maintain self cleansing velocities. It becomes difficult to meet both conditions with increasing variation in rate of flow. Where differences in elevations are insufficient to permit gravity flow, pumping may be required. The cost of construction, operation, and maintenance of pumping stations are compared with the cost of construction and maintenance of gravity sewers. Apart from the cost considerations the consequences of mechanical and electrical failures at pumping stations may also be considered, which may necessitate a gravity system even at a higher cost.

3.5.3 Layout of Systems

The sewerage system layout involves the following steps

- i) Selection of an outlet or disposal point
- ii) Prescribing limits to the drainage valley or Zonal Boundaries
- iii) Location of Trunk and Main Sewers
- iv) Location of Pumping Stations if found necessary

In general the sewers will slope in the same direction as the street or ground surface and will be connected by Trunk Sewers. The discharge point may be a treatment plant or a pumping station or a water course, a trunk or intercepting sewer. It is desirable to have discharge boundaries following the property limits. The boundaries of sub zones are on the basis of topography, economy or other practical consideration. Trunk and main sewers are located in the valleys.

The most common location of sanitary sewer is in the centre of the street. A single sewer serves both sides of the street with approximately same length for each house connection. In very wide streets

it may be economical to lay a sewer on each side, in such case the sewer may be adjacent to curb or under the footpath. Interference with other utilities has to be avoided. Sometimes sewers may be located in the back of property lines to serve parallel rows of houses in residential area. However access to such locations becomes difficult and hence sewer locations in streets are often preferred. Sewers as a rule are not located in proximity to water supplies. When such situations are unavoidable the sewers may be encased in sleeve pipes or encased in concrete. Tees or Wyes should be provided for all house connections both for present and future locations so as to avoid breaking a hole into the side of a sewer.

3.5.3.1 PLANS

The following procedure is recommended for the nomenclature of sewers:

The trunk sewer should be selected first and drawn and other sewers should be considered as branches. The trunk sewer should be the one with the largest dia that would extend farthest from the outfall works. Whenever two sewers meet at a point, the main sewer is the larger of the incoming sewers. The manholes of the trunk sewer are designated as 0, 1, 2, 3 etc. commencing at the lower end (outfall end) of the line and finishing at the top end. Manholes on the mains or submains are again numbered 1, 2, 3, etc., prefixing the number of the manhole on trunk/main sewer where they join (e.g. 3.2 represents the second manhole on the main sewer from the manhole no. 3 on the trunk sewer). When all the sewer lines connected to the main line have thus been covered by giving distinctive numbers to the manholes, the manholes on the further branches to the branch mains are similarly given distinctive numbers, again commencing with the lower end. If there are two branches, one on each side meeting the main sewer or the branch sewer, letter 'L' (to represent left) or letter 'R' (to represent right) is again prefixed to the numbering system, reckoning against the direction of flow. If there is more than one sewer either from the left or right they are suitably designated as L_1, L_2, R_1, R_2 , the subscript referring to the line near to the sewer taking away the discharge from the manhole.

Thus $L_2 R_1 4.2.3$ (Figure 3.8) will pinpoint a particular manhole on the submain from which the flow reaches manhole number 4 on the trunk sewer through a submain and a main. The first numeral (from the left) is the number of the manhole on the trunk sewer. The numerals on the right of this numeral, in order, represent the manhole numbers in the main, submain etc., respectively. The first letter immediately preceding the numeral denotes the main and that it is to the right of the trunk sewer. Letters to the left in their order represent submain, branch respectively. The same nomenclature is used for representing the sections e.g. Section $L_2 R_1 4.2.3$ identifies the section between the manhole $L_2 R_1 4.2.3$ and the adjoining downstream manhole. All longitudinal sections should be indicated with reference to the same datum line. The vertical scale of the longitudinal sections should be magnified ten times the horizontal scale.

Once the rough sections have been prepared the designer should go over the work for improving the spacing of manholes, the sizes and gradients of the sewers and so forth, economising on materials and excavation to the extent possible but at the same time making sure that the sewer will serve all users and that they can be actually laid according to the alignments shown in the drawing and have sufficient gradients. The sewers should have a minimum cover of 1 m at the starting point or otherwise adequately protected with cement concrete encasing.

The following scales may be adopted for the various plans and drawings:

(a) Index Plan	-	1:100,000 or 1:200,000
(b) Keyplan & general layout	-	1:10,000 or 1:20,000
(c) Zonal Plans	-	1:2,500 or 1:5,000
(d) Longitudinal sections of sewers	-	1:500 or 1:1,250 or 1:2,500
(e) Structural drawings	-	1:20 or 1:50 or 1:100 or 1:200

The sewers should be shown as thick lines and manholes as small circles in plan. In section the sewer may be indicated by a line or two lines depending upon the diameters and scales adopted. Grade, size and material of pipe, ground and invert levels and extent of concrete protection should be indicated as shown in Figure 3.10.

Standard vertical plan filing systems are now available and are very convenient for storing of plans and taking them out quickly for reference. Normally, size A0 and A1 (trimmed size 841 x 1189 mm and 594 x 841 mm respectively) should be used while submitting the project drawings for approval.

All documents including drawings, design calculations, measurement sheets of estimates, etc., should be in metric system. In drawings, length should be indicated either entirely in metres correct upto two decimals or entirely in millimetres (for thickness etc.). If this practice is followed, units would be obvious and in certain cases writing of m or mm with the figure can be omitted. The flow should normally be indicated in litres per second (lps) or cubic metres per hour (m^3/hr) except for very large flows which may be indicated in cubic metres per second (cumec). For uniformity, lps for sewage flows and cumec for storm flows is recommended. Similarly, areas in sewer plans and design calculations may be indicated in hectares (ha). While writing figures they should be grouped into groups of three with a single space between each group and without comma. In case of a decimal number, this grouping may be on either side of the decimal (e.g. 47 342.294 31).

In case of design of sewer network using computer programme, there is no restriction in the nomenclature of the sewers and manholes as required for the manual design. It is sufficient to give node numbers as well as pipe (link) numbers in any manner in the sewer network for design of the network for using computer software. The numbering of the network may be adopted as shown in the diagram enclosed (Fig. 3.9).

3.5.4 Design Approach

3.5.4.1 DESIGN STEPS

The first step in the hydraulic design of a sewer network is to prepare a map showing locations of all sewers and measure the contributory area to each point. Profiles along each sewerline are also to be marked. Critical levels such as basements of low lying houses and other buildings, levels of existing sewers to be intercepted high water levels in trunk sewers or disposal points have to be noted. Sewer network design computations are repetitive and hence can be easily done by Tabular form or by using suitable computer soft ware programmes.

For design of sewer network the slope and diameter of sewers should be decided to meet the following two conditions:

- 1) A self cleansing velocity is maintained at present peak flow
- 2) A sewer runs at 0.80 full at ultimate peak flow

Appendix 3.5 gives a worked example of designing a sewer system. Appendix 3.6 gives a design of sewer network using a computer programme in BASIC.

3.6 SMALL BORE SEWER SYSTEM

3.6.1 System Description

Small bore sewer system is designed to collect and transport only the liquid portion of the domestic wastewater for off-site treatment and disposal. The solids are separated from the wastewater in septic

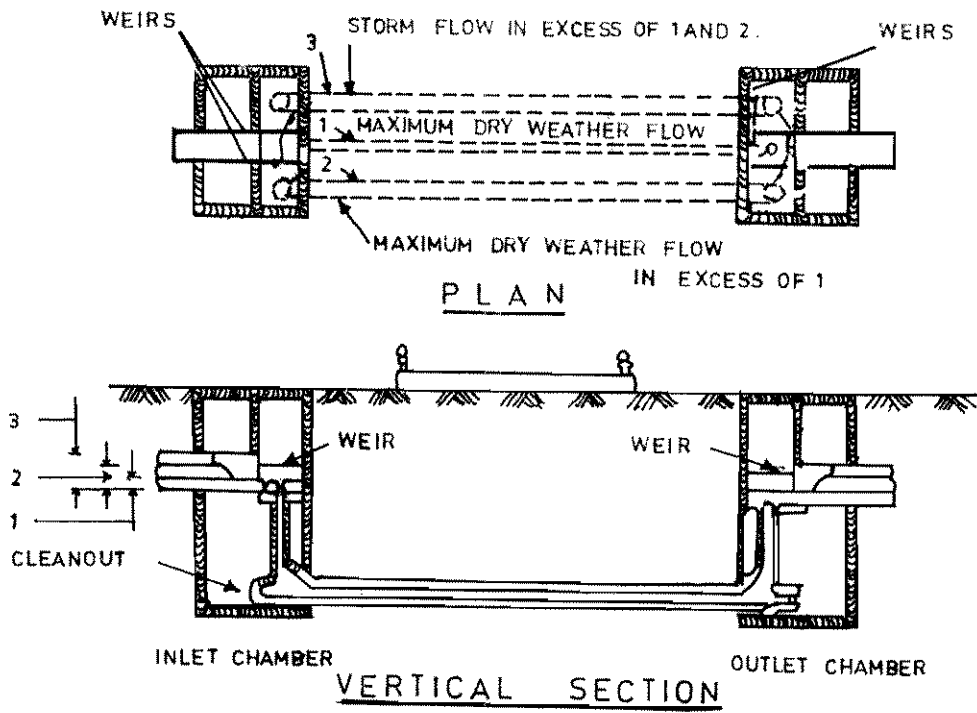

FIG. 3.7: INVERTED SIPHON OR SUPPRESSED SEWER FOR COMBINED SEWAGE.

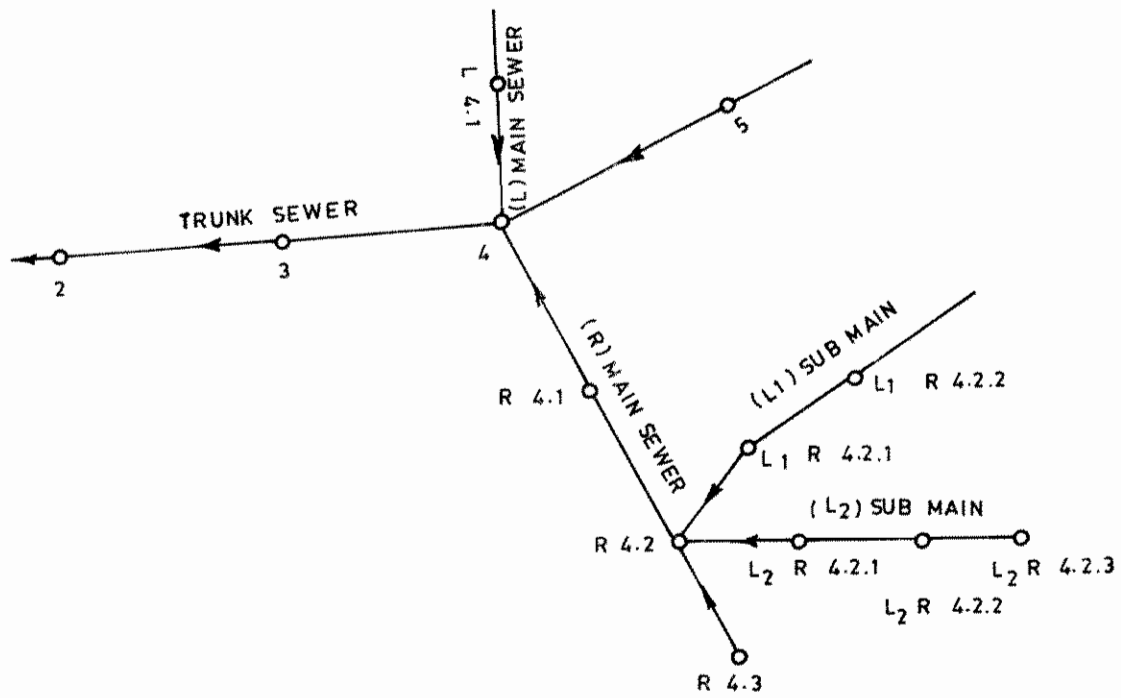

FIG. 3.8 : NOMENCLATURE OF SEWERS

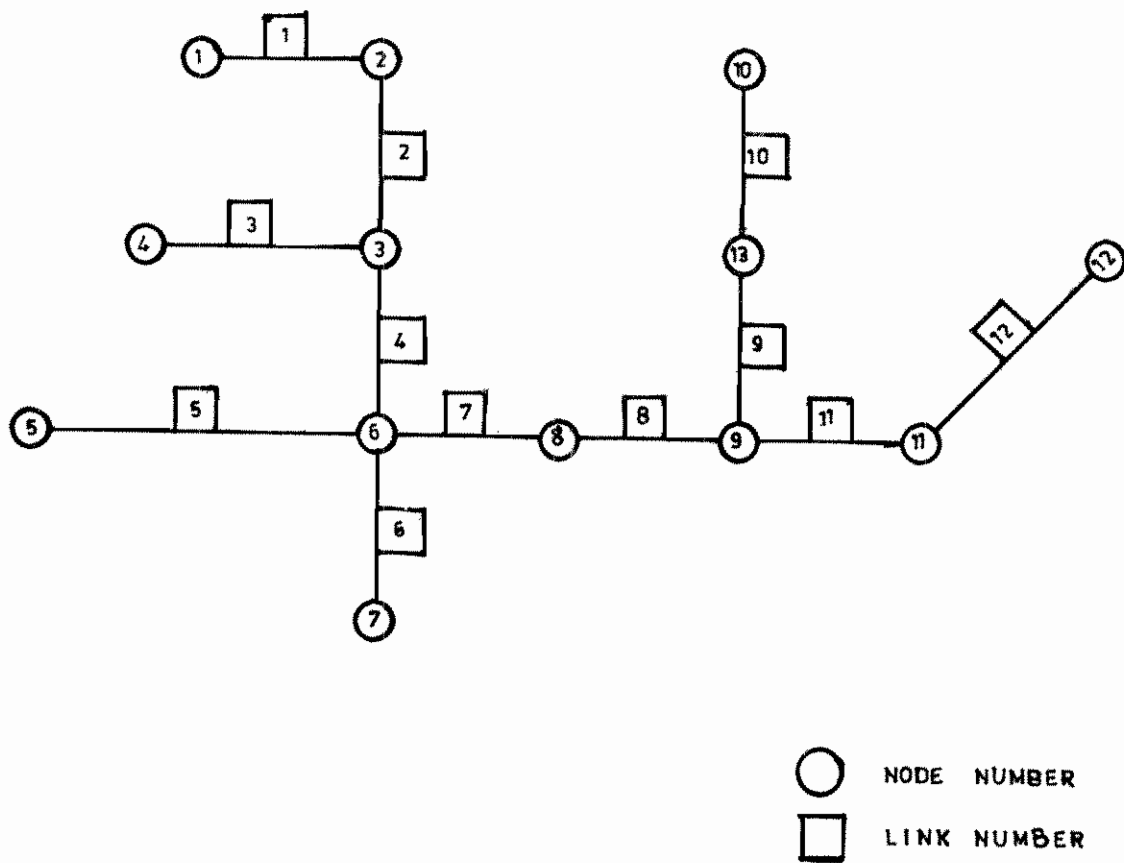

FIG.3.9:EXAMPLE SEWER NETWORK

tanks or aqua privies installed upstream of every connection to the small bore sewers. Where conventional sewers would be inappropriate or infeasible, this system provides an alternative. This system also provides an economical way to upgrade the existing on-site sanitation facilities to a level of service comparable to conventional sewers. Since the small bore sewer collects only settled wastewater, it needs reduced water requirements and reduced velocities of flow. This in turn reduces the cost of excavation, material and treatment.

3.6.2 Components of the System

The small bore sewer system consists of house connections, interceptor tanks, sewers, cleanouts and manholes, vents and in some cases lift stations.

3.6.3 Suitability of the System

This system is suitable under the following conditions : Where

1. effluent from pour-flush toilets and household sullage cannot be disposed off on-site
2. installation of new schemes is taken up, especially for fringe areas
3. a planned sequence of incremental sanitation improvements with small bore sewers as a first stage is contemplated
4. existing septic tank systems have failed or where there are a number of septic tanks requiring the effluent to be discharged but soil and ground water conditions do not permit such a discharge.

3.6.4 Design Criteria

Each house sewer is usually connected to an interceptor tank which is designed as a septic tank. The optimum number of house sewers to be connected to an interceptor tank can be worked out for each case. The effluent from the tank is discharged into the small bore sewer system, where flow occurs by gravity utilising the head resulting from the difference in elevation of its upstream and downstream ends. The sewer should be set deep enough to carry these flows.

A design peak flow factor of 2.0 is adopted. At peak flow, the sewer is to flow full. Where pumping is to be done, the peak flow rate will be equal to the pump discharge rate, unless the pumping cycle is less than five minutes. Unlike conventional gravity sewers which are designed for open channel flow, small bore sewers may be installed with sections depressed below the hydraulic grade line. Design decisions regarding the location, depth, size and gradient of the sewer must be carefully made to hold hydraulic losses within the limits of available head. Minimum pipe diameter of 100 mm is recommended. Maintenance of strict sewer gradients to ensure minimum self-cleansing velocities is not necessary. Minimum velocities in the range of 0.3 - 0.6 m/s may be used. The sewer may be constructed with any profile as long as the hydraulic gradient remains below all interceptor tank outlet inverts.

Ventilation is not necessary for small bore sewers, if they are laid on a falling gradient. A vent cleanout to release air may be provided at every hump.

3.6.5 Appurtenances

Cleanouts are used in place of manholes, except at major junctions and should be located at all upstream ends, intersections of sewer lines, major changes in direction, at high points and at intervals of 60-100 m in straight reaches to long flat sections. Pumping may be provided to overcome elevation conditions or to raise collected wastewater from one drainage zone to another. Long pumping intervals should be avoided to prevent excessively surcharged conditions in the small bore sewers.

3.6.6 Disposal of Effluent

The effluent from small bore sewers can be discharged into conventional sewerage system if possible; otherwise the effluent from small bore sewers can be treated through waste stabilisation ponds, any other low cost treatment followed by fish ponds, or land treatment with the usual precautions.

3.6.7 Limitations

1. The interceptor tanks need periodical cleaning and disposal of solids. This requires an organisation for maintenance of these interceptors to ensure satisfactory performance of the system.
2. Special precautions should be taken to prevent illegal direct connections into sewers without interceptor and dumping of solid waste into interceptors, cleanouts and manholes.

One or more houses may be connected to an interceptor tank through house connections.

3.7 SHALLOW SEWERS

3.7.1 System Description

Shallow sewers are designed to receive domestic sewage for off-site treatment and disposal. They are a modification of the surface drain with covers and consist of a network of pipes laid at flat gradients in locations away from heavy imposed loads (usually in backyards, sidewalks and lanes of planned and unplanned settlements). They are usually laid at a minimum depth of 0.4 m. Where vehicular loading is present and the invert depth of sewer is less than 0.8 m, a concrete encasement is provided for the sewer.

3.7.2 Components of the System

The shallow sewer system, like the conventional sewer system consists of house connections, inspection chambers, laterals, street collector sewers, pumping stations where necessary and treatment plants. Low volume pour-flush or cistern-flush waterseal toilets are connected to the inspection chamber by means of a 75 mm diameter sewer. A vertical ventilation column of the same diameter is provided on the house connection. The sullage water generated in the house is also connected to the inspection chamber directly when water consumption is more than 75 lpcd. Where the water consumption is lesser and where grit is used for cleaning purpose, it is connected through a grit/grease trap. Inspection chambers are provided along the street collector sewers and along the length of the laterals at intervals not exceeding 40 m. Usually one chamber is provided for each house. However two or more houses may share a single inspection chamber. The chamber is provided with a tight-fitting RCC cover.

The laterals are of small diameters (min.100 mm) and of stoneware or concrete which are buried in a shallow trench. The minimum depth of pipe invert is 0.4 m. In general, they have straight alignment between inspection chambers and are suitably aligned around existing buildings. They may even pass under property boundary walls and also under future building areas. The inspection chamber however is located in an open area.

The street collector sewer has a usual minimum diameter of 150 mm, however 100 mm sewers may also be used if hydraulic capacities permit. Where community septic tanks are provided at the exit of lateral sewers, the street sewers should be designed as small-bore sewers.

Pumping stations should, as far as possible, be eliminated.

3.7.3 Applicability

Shallow sewers are suitable where

1. high density slums and squatter settlements (usually 100 to 160 persons per hectare) exist
2. adverse ground conditions exist and on-site disposal is not possible
3. sullage also has to be disposed off and where the minimum water consumption rate is 25 lpcd.

3.7.4 Limitations

Shallow sewerage system is suitable where adequate ground slopes are available. Since these sewers are laid at flat gradients the solids are likely to get deposited unless flushed at peakflow conditions. Otherwise these sewers may get clogged and require frequent cleaning.

3.8 NON CIRCULAR SEWERS

The Mannings Formula alongwith appropriate coefficients of roughness (Table 3.4) can be used for design of box type ducts for conveying sewage and open drains for carrying storm water.

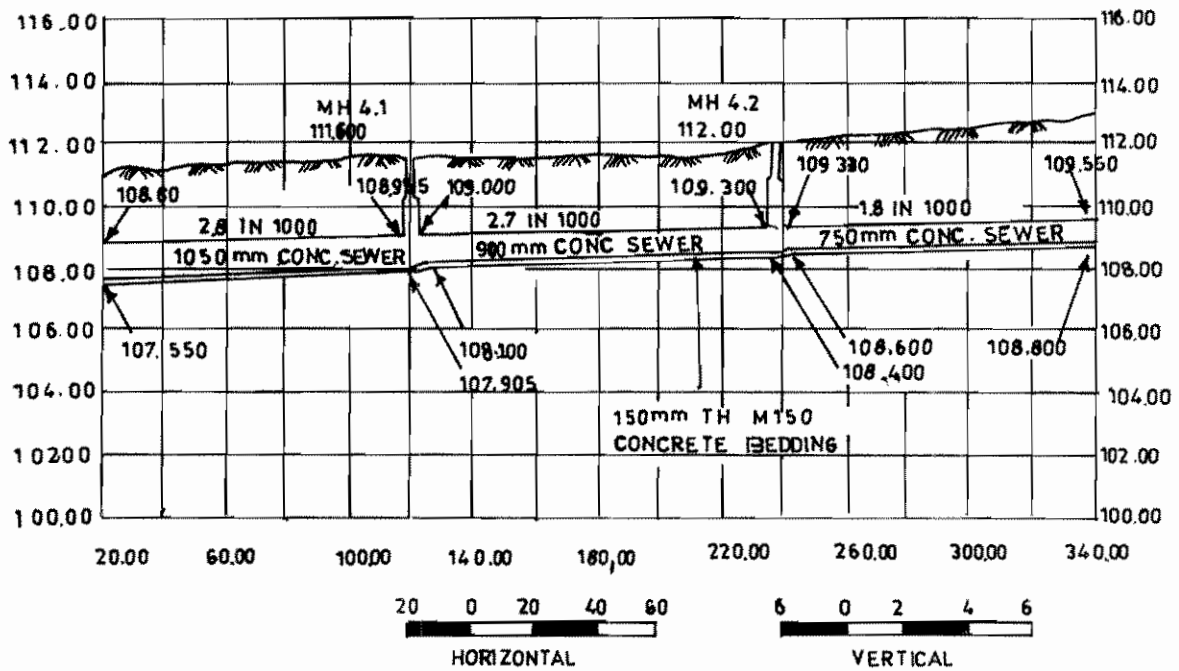

FIG.3.10 : A TYPICAL SEWER SECTION

SEWER APPURTENANCES

4.1 INTRODUCTION

Sewer appurtenances are devices necessary, in addition to pipes and conduits, for the proper functioning of any complete system of sanitary, storm or combined sewers. They include structures and devices such as various types of manholes, lampholes, gully traps, intercepting chambers, flushing tanks, ventilation shafts, catch-basins, street inlets, regulators, siphons, grease traps, side flow weirs, leaping weirs, venturi-flumes and outfall structures.

4.2 MANHOLES

4.2.1 Ordinary Manholes

A manhole is an opening constructed on the alignment of a sewer for facilitating a person access to the sewer for the purpose of inspection, testing, cleaning and removal of obstructions from the sewer line.

4.2.1.1 SPACING

Manholes should be built at every change of alignment, gradient or diameter, at the head of all sewers and branches and at every junction of two or more sewers. On sewers which are to be cleaned manually, which cannot be entered for cleaning or inspection, the maximum distance between manholes should be 30 m.

The spacing of manholes on large sewers above 900mm diameter is governed by the following for the sewers to be cleaned manually:

- a) The distance upto which silt or other obstruction may have to be conveyed along the sewer to the nearest manhole for removal
- b) The distance upto which materials for repairs may be conveyed through the sewer and
- c) Ventilation requirements for men working in the sewer.

For sewers which are to be cleaned with mechanical devices, the spacing of manholes will depend upon the type of equipment to be used for cleaning sewers.

The spacing of manholes above 90 to 150m may be allowed on straight runs for sewers of diameter 900 to 1500 mm. Spacing of manholes at 150 to 200 m may be allowed on straight runs for sewers of 1.5 to 2.0 m dia., which may further be increased upto 300m for sewers of over 2m diameter. A spacing allowance of 100m per 1m dia of sewer is a general rule in case of very large sewers.

4.2.1.2 CONSTRUCTIONAL DETAILS

Manholes are usually constructed directly over the centre line of the sewer. They are circular, rectangular or square in shape. Manholes should be of such size as will allow necessary cleaning and inspection of manholes.

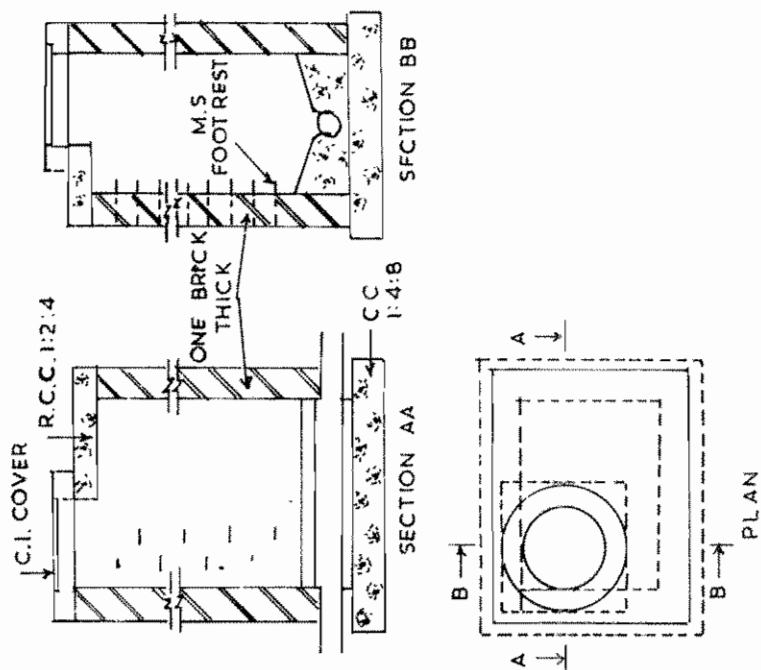

FIG. 4.2: TYPICAL ILLUSTRATION OF RECTANGULAR MANHOLE FOR DEPTH FROM 0.90M UPTO 2.5M (SIZE 1200 x 900 mm)

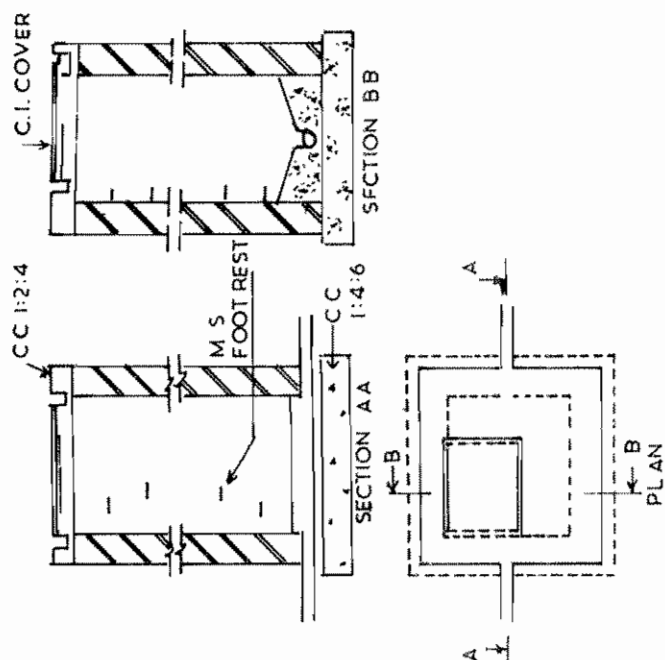

FIG. 4.1: TYPICAL ILLUSTRATION OF RECTANGULAR MANHOLE FOR DEPTH LESS THAN 0.90M (SIZE 900 x 800 mm)

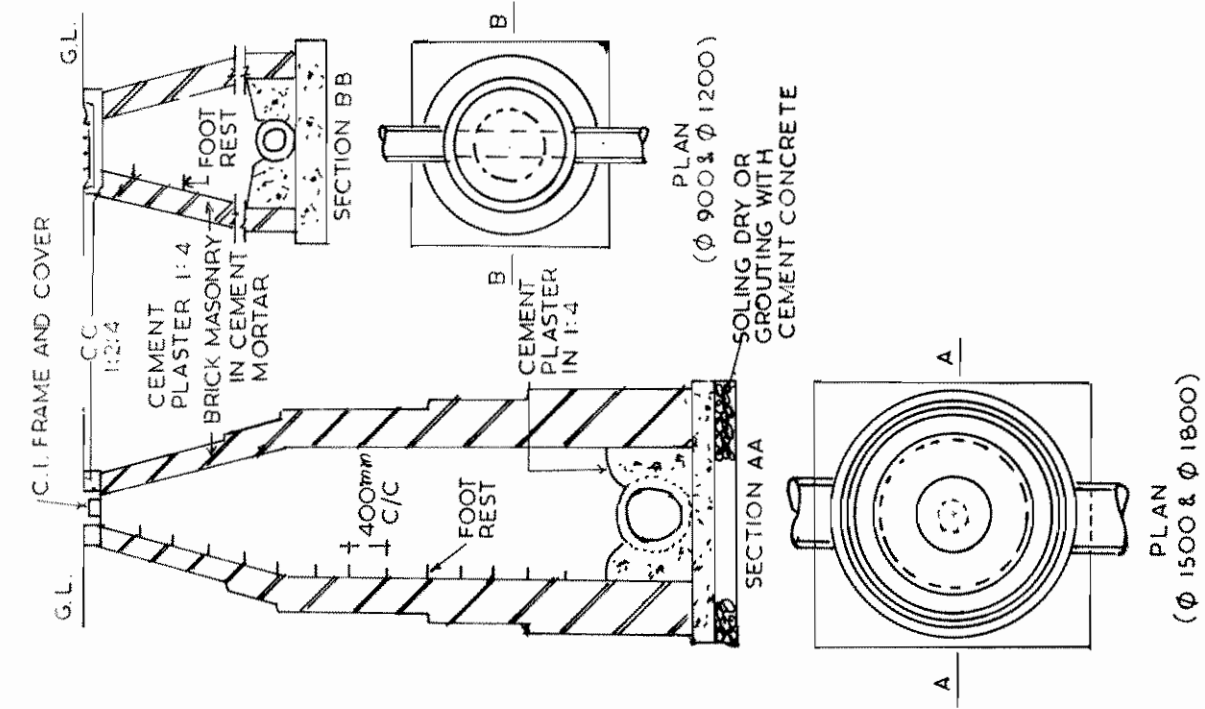

FIG 4.4 TYPICAL ILLUSTRATION OF CIRCULAR MANHOLES
(ALL DIMENSIONS ARE IN mm)

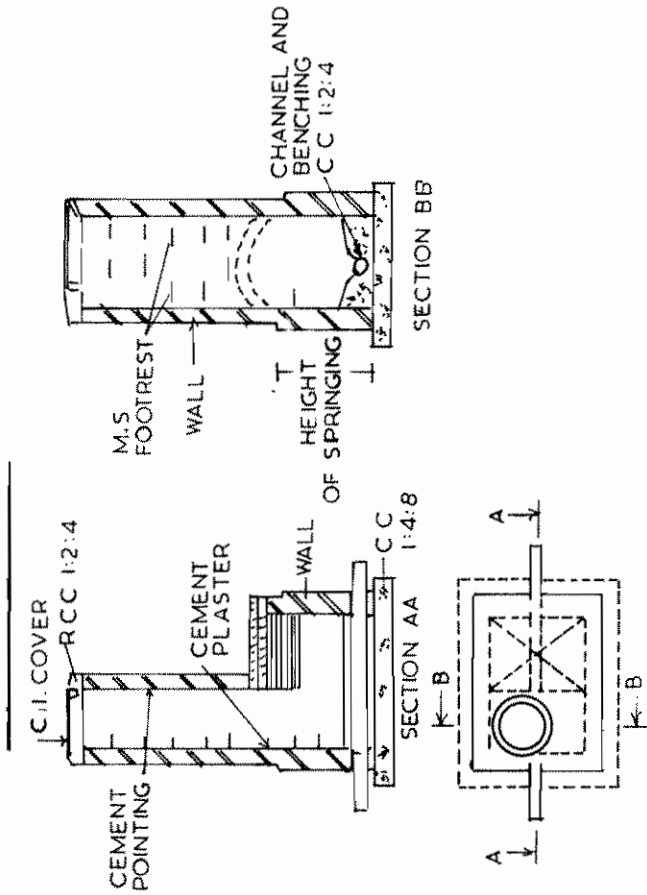

FIG.4.3: TYPICAL ILLUSTRATION OF ARCHED TYPE MANHOLE

- a) **Rectangular Manholes** The minimum internal sizes of rectangular manholes (Fig.4.1 & Fig.4.2) between brick faces should be as follows:
- i) For depths of manholes less than 0.90m, 900 x 800mm and
 - ii) For depths of manholes from 0.9m and upto 2.5m, 1200 x 900mm
- b) **Arch Type Manholes** For depths of 2.5m and above, arch type manholes (Fig.4.3) can be provided and the internal sizes of chambers between brick faces shall be 1400 x 900mm. The width of manhole chamber on bends and junctions of pipes with diameter greater than 450mm, should be suitably increased to 900mm or more so that benching width on either side of channel is atleast 200mm.
- c) **Circular Manholes** The circular manholes may be constructed as alternative to rectangular and arch type manholes.

Circular manholes are stronger than rectangular and arch type manholes and thus these are preferred over rectangular as well as arch type manholes.

The circular manholes can be provided for all depths starting from 0.9m. Circular manholes are straight down in lower portion and slanting in top portion so as to narrow down the top opening equal to internal dia of manhole cover. Depending upon the depth of manhole, the diameter of manhole changes. The internal diameter of circular manholes may be kept as following for varying depths:

- i) For depths above 0.90m and upto 1.65m, 900mm diameter
- ii) For depths above 1.65m and upto 2.30m, 1200mm diameter
- iii) For depths above 2.30m and upto 9.0m, 1500mm diameter
- iv) For depths above 9.0m and upto 14.0m, 1800mm diameter.

Some types of circular manholes have been shown in Fig.4.4.

If the sewer is constructed in a tunnel, the manhole should be located at the access or working shafts and the manhole chamber may be constructed of a size to suit the working shaft or vice-versa.

The width/diameter of the manhole should not be less than internal diameter of the sewer + 150mm benching on both sides (150mm + 150mm).

The opening for entry into the manhole (without cover) should be of such minimum dimensions as to allow a workman with the cleaning equipments to get access into the interior of the manhole without difficulty. A circular opening is generally preferred. A minimum clear opening of 60cm is recommended. Suitable steps usually of malleable cast iron shall be provided for entry.

Access Shafts for large Sewers - Access shaft shall be circular in shape and shall have a minimum internal dia of 750mm, where the depth of the shaft exceeds 3m suitable dimensions shall be provided to facilitate cleaning and maintenance.

Access shaft where built of brickwork should be corbelled on three sides to reduce it to the size of the opening in the cover frame, and to provide easy access on the fourth side to step irons or ladder. In determining sizes, the dimensions of the maintenance equipment likely to be used in the sewers, shall be kept in view.

Where the diameter of the sewer is increased, the crown of the entering and leaving pipes shall be fixed at the same level and necessary slope is given in the invert of the manhole chamber. In exceptional cases and where unavoidable, the crown of entering sewer may be fixed at lower level but in such cases too the peak flow level of the two sewers shall be kept the same.

A slab, generally of plain cement concrete atleast 150mm thick should be provided at the base to support the walls of the manhole and to prevent the entry of ground water. The thickness of the base also shall be suitably increased upto 300mm, for manholes on large dia. sewers, with adequate reinforcement provided to withstand excessive uplift pressures. In the case of larger manholes, the flow in the sewer should be carried in U-shaped smooth channel constructed integrally with the concrete base of the manhole. The side of the channel should be equal to the dia. of the largest sewer pipe. The adjacent floor should have a slope of 1 in 10 draining to the channel. Where more than one sewer enters the manhole the flow through channel should be curved smoothly and should have sufficient capacity to carry the maximum flow.

It is desirable to place the first pipe joint outside the manhole as close as practicable. The pipe shall be built inside the wall of the manhole flush with the internal periphery protected with an arch of masonry or cement concrete to prevent it from being crushed.

The sidewalls of the manhole are usually constructed of cement brick work 250mm thick and corbelled suitably to accommodate the frame of the manhole cover.

The inside and outside of the brickwork should be plastered with cement mortar 1:3 (1 cement: 3 coarse sand) and inside finished smooth with a coat of neat cement.

Where subsoil water condition exists, a richer mix may be used and it shall further be waterproofed with addition of approved water proofing compound in a quantity as per manufacturer's specifications.

4.2.1.3 COVERS AND FRAMES

The size of manhole covers should be such that there should be clear opening of not less than 560mm diameter for manholes exceeding 0.9m depth.

When cast iron manhole covers and frames are used they shall conform to IS:1726 (parts 1 to 7). The frames of manhole shall be firmly embedded to correct alignment and level in plain concrete on the top of masonry. After completion of the work, manhole covers shall be sealed by means of thick grease.

Where sewers are to be laid in high subsoil water conditions, manholes may be constructed in reinforced cement concrete of grade M 20 or 1:1 1/2:3. The manholes in this type of construction shall be preferably circular type (Fig.4.5).

Heavy reinforced concrete covers with suitable lifting arrangements could also be used instead of C.I. manhole covers. Reinforcing materials other than Mild Steel are being tried. However Precast Cement Concrete covers reinforced by materials other than Mild Steel should be used provided that those are properly tested & certified for use by competent authority. Fibre Reinforced Plastic covers (FRP) conforming to relevant I.S. may be used wherever such covers are available.

4.2.2 Types of Manholes

4.2.2.1 STRAIGHT THROUGH MANHOLES

The simplest type of manhole is that built on a straight run of sewer with no side junctions.

Where there is a change in the size of sewer, the soffit or crown level of the two sewers should be the same, except where special conditions require otherwise.

4.2.2.2 JUNCTION MANHOLES

A manhole should be built at every junction of two or more sewers, and the curved portions of the inverts of tributary sewers should be formed within the manhole. To achieve this with the best economy of space, the chamber may be built of a shape other than rectangular. The soffit of the smaller sewer at a junction should be not lower than that of the larger sewer, in order to avoid the surcharging of the former when the latter is running full, and the hydraulic design usually assumes such a condition.

The gradient of the smaller sewer may be steepened from the previous manhole sufficiently to reduce the difference of invert level at the point of junction to a convenient amount.

4.2.2.3 SIDE ENTRANCE MAN HOLES

In large sewers or where it is difficult to obtain direct vertical access to the sewer from ground level, owing to existing services, gas, water, etc., the access shaft should be constructed in the nearest convenient position off the line of sewer, and connected to the manhole chamber by a lateral passage.

In the tunnelled sewers the shaft and lateral access heading may be used as a working shaft, the tunnel being broken out from the end of the heading, or alternatively the shaft and heading may be used as a working shaft, the tunnel being broken out from the end of the heading, or alternatively the shaft and heading may be constructed after the main tunnel is complete, provision having been made for breaking in from the access heading to build the chamber.

The floor of the side-entrance passage, which should fall at about 1 in 30 towards the sewer, should enter the chamber not lower than the soffit level of the sewer. In large sewer where the floor of the side entrance passage is above the soffit either steps or a ladder (which should be protected either by a removable handrail or by safety chains) should be provided to reach the benching.

4.2.2.4 DROP MANHOLES

When a sewer connects with another sewer, where the difference in level between water lines (peak flow levels) of main line and the invert level of branch line is more than 600mm or a drop of more than 600mm is required to be given in the same sewer line and it is uneconomical or impractical to arrange the connection within 600mm, a drop connection shall be provided for which a manhole may be built incorporating a vertical or nearly vertical drop pipe from the higher sewer to the lower one. This pipe may be either outside the shaft and encased in concrete or supported on brackets inside the shaft, which should be suitably enlarged. If the drop pipe is outside the shaft, a continuation of the sewer should be built through the shaft wall to form a rodding and inspection eye, which should be provided with a half blank flange. If the drop pipe is inside the shaft, it should be in cast iron and it would be advantageous to provide adequate means for rodding and water cushion of 150mm depth should also be provided. The diameter of the back drop should be atleast as large as that of the incoming pipe. A typical illustration of a drop manhole is shown in Fig.4.6.

The drop pipe should terminate at its lower end with a plain or duck-foot bend turned so as to discharge its flow at 45 degrees or less to the direction of the flow in the main sewer and the pipe, unless of cast iron, should be surrounded with 150mm of concrete.

In the case of sewers over 450mm in diameter the drop in level may be accomplished by one of the following methods:

- a) **A Cascade** - This is a steep ramp composed of steps over which the flow is broken up and retarded. A pipe connecting the two levels is often concreted under the steps

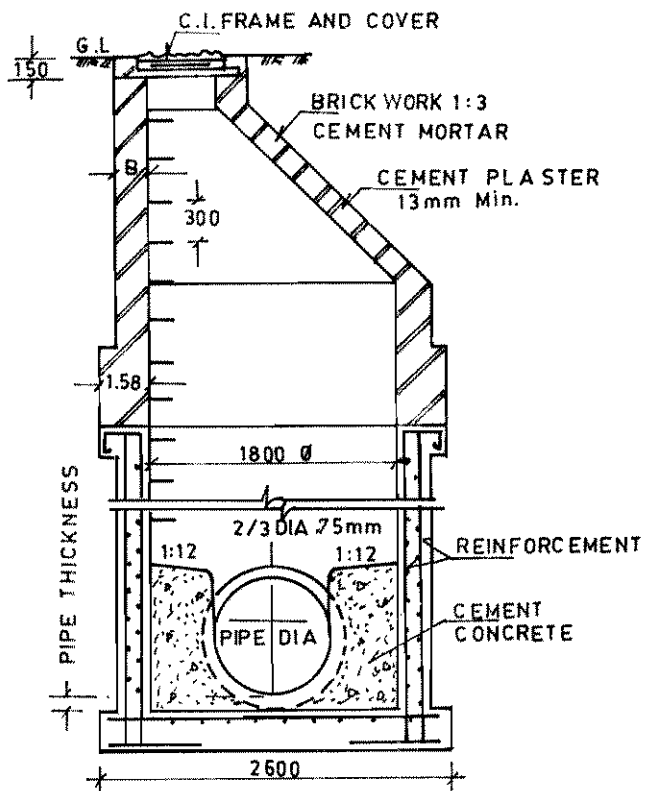

B . THICKNESS OF WALL
ALL DIMENSION IN MILLIMETRES.

FIG. 4.5 : TYPICAL ILLUSTRATION OF R.C.C. MANHOLE
(CONCRETE NOT SHOWN)

to allow small flows to pass without trickling over the steps. The cascade steps may be made of heavy duty bricks of Class I quality (IS:2180-1985), cement concrete with granolithic finish or dressed granite

- b) **A Ramp** - A ramp may be formed by increasing the grade of the last length of the upper sewer to about 45 degrees or by constructing a steeply graded channel or culvert leading from the high level to the low level sewer. In order to break up the flow down the ramp and minimize the turbulence in the main sewer, the floor of a culvert ramp should be obstructed by raised transverse ribs of either brick or concrete at 1.15m intervals and a stilling pool provided at the bottom of the ramp and
- c) **By Drops in Previous Successive Manholes** - Instead of providing the total drop required at the junction manhole, the same may be achieved by giving smaller drops in successive manholes preceding the junction manhole. Thus, for example, if a total drop of 2.4m is required to be given, 0.6m drop may be given in each of the previous three manholes and the last 0.6m drop may be given at the junction manhole.

4.2.2.5 SCRAPER (SERVICE) TYPE MANHOLE

All sewers above 450mm in diameter should have one manhole at intervals of 110 to 120m of scraper type. This manhole should have clear opening of 1200 x 900mm at the top to facilitate lowering of buckets.

4.2.2.6 FLUSHING MANHOLES

Where it is not possible to obtain self cleansing velocities due to flatness of the gradient especially at the top ends of branch sewers which receive very little flow, it is essential that some form of flushing device be incorporated in the system. This can be done by making grooves at intervals of 45 to 50m in the main drains in which wooden planks are inserted and water allowed to head up and which will rush on with great velocity when the planks are removed. Alternatively, an overhead water tank is built, from which connections are made through pipes and flushing hydrants to rush water to the sewers. The relevant Indian Standard is IS:4111 (part-2).

Flushing can be very conveniently accomplished by the use of a fire hydrant or tanker and hose.

Where flushing manholes are provided, they are located generally at the head of a sewer. Sufficient velocity shall be imparted in the sewer to wash away the deposited solids. The flush is usually effective upto a certain distance after which the imparted velocity gets dissipated.

The automatic systems which are operated by mechanical units get often corroded by the sewer gases and do not generally function satisfactorily and hence are not recommended.

In case of hard chokages in sewers, care should be exercised to ensure that there is no possibility of backflow of sewage into the water supply mains.

Approximate quantities of water needed for flushing are as follows:

Slope	Quantity of Water (Litres)		
	200mm dia.	250mm dia.	300mm dia.
0.0050	2300	2500	3000
0.0075	1500	1800	2300
0.0100	1300	1500	2000
0.0200	500	800	1000
0.0300	400	500	700

4.3 INVERTED SIPHONS

An inverted siphon or depressed sewer is a sewer that runs full under gravity flow at a pressure above atmosphere in the sewer, the profile being depressed below the hydraulic grade line. Since the inverted siphon is in no sense a true siphon, an attempt has been made, but with indifferent success, to popularise the term depressed sewer for this device. In sewerage practice the word siphon has come to mean an inverted siphon unless otherwise qualified. Siphons, both true and inverted are used in sewers to pass over or under obstacles such as buried pipes, subways and stream beds. As the siphon is an appurtenance requiring considerable attention for maintenance, it should be used only where other means of passing an obstacle in line of the sewer are impracticable. The relevant Indian Standard is IS:4111 (part-3) More details of inverted siphons are discussed in 3.4.5.

4.4 HOUSE SEWER CONNECTIONS

For large diameter of sewers, house connections may be given through rider sewers. Sewers should be connected through manhole or drop manhole. Where there is no Y or T left for new connections, insertion of new Y or T is not prescribed.

House sewer connections should preferably be 150mm or more in dia with a minimum slope of 1:60 laid as far as possible, to a straight line and grade. Connections to the main street sewer should normally be made with Y branches. For sewers deeper than 5m, tees are preferable to facilitate connections at higher elevations, particularly where simultaneous discharge of house sewers into the street sewer is not expected and also prevent damage while rodding.

The Y or tee may be installed with the branch turned about 45 degrees from the horizontal so that back-flooding of the house connection will not occur when the collecting sewers flow full. Connections to large sewers are for the same reason made above the spring line of the main sewer. The house connection for deep sewers, where made by means of a vertical pipe riser, shall be encased in concrete at least 75mm thick and upto the full length of the pipe to prevent damage during backfilling.

All possible practical provision should be made for future connections in the original construction. Where possible, property connection chambers shall be constructed close to the property line to facilitate easier future connections. If possible more refined methods of cutting the sewers may be used to make the house connections without disturbing sewage flow. Connections to existing sewers, particularly those of small diameter, should wherever possible be made with these tees or Ys. The free end of the service lines or branches should be closed with a carefully fitted stopper, when service lines are not yet connected to buildings or where intermediate connections are not yet made with the tee or Y branches.

The recent practice is to make the house connection directly without providing intercepting traps. The deletion of the intercepting traps at the sewer connection provides effective ventilation of the sewer system without the use of ventilators. Intercepting traps may be useful for multistoried houses.

4.5 STORM WATER INLETS

These are devices meant to admit the surface runoff to the sewers and form a very important part of the system. Their location and design should therefore be given careful consideration.

Storm water inlets may be categorised under three major groups viz. curb inlets, gutter inlets and combination inlets, each being either depressed or flush depending upon their elevation with reference to the pavement surface.

The actual structure of an inlet is usually made of brickwork. Normally, cast iron gratings conforming to I.S.5961 shall be used. In case there is no vehicular traffic, fabricated steel gratings may be used. The clear opening shall not be more than 25mm. The connecting pipe from the street inlet to the main street sewer should not be less than 200mm in dia. and should have sufficient slope.

Maximum spacing of inlets would depend upon various conditions of road surface, size and type of inlet and rainfall. A maximum spacing of 30m is recommended.

4.5.1 Curb Inlets

Curb inlets are vertical openings in the road curbs through which the storm water flows and are preferred where heavy traffic is anticipated.

They are termed as deflector inlets when equipped with diagonal notches cast into the gutter along the curb opening to form a series of ridges or deflectors. This type of inlet does not interfere with the flow or traffic as the top level of the deflectors lie in the plane of the pavement.

4.5.2 Gutter Inlets

These consist of horizontal openings in the gutter which is covered by one or more gratings through which the flow passes.

4.5.3 Combination Inlets

These are composed of a curb and gutter inlet acting as a single unit. Normally, the gutter inlet is placed right in front of the curb inlets but it may be displaced in an overlapping or end-to-end position. Figure 4.7 shows different types of inlets.

4.6 CATCH BASINS

Catch basins are structures meant for the retention of heavy debris in storm water which otherwise would be carried into the sewer system. Their use is not recommended since they are more of a nuisance and a source of mosquito breeding apart from posing substantial maintenance problems.

Where a main sewer is laid and the sewer network is not yet laid, the dry weather flow from the open drains may be connected to the sewers by making a provision for a catch basin and overflow weir.

4.7 REGULATOR OR OVERFLOW DEVICE

These are used for preventing overloading of sewers, pumping stations, treatment plants, or of disposal arrangements, by diverting the excess flows to relief sewers etc.

The overflow devices may be sideflow or leaping weirs according to the position of the weir, siphon spillways or float actuated gates and valves.

4.7.1 Side Flow Weir

A side flow weir constructed along one or both sides of a combined sewer delivers excess flows during storm periods to relief sewers or natural drainage courses. The crest of the weir is set at an elevation corresponding to the desired depth of flow in the sewer. The weir length must be sufficiently long for effective regulation.

The length of the side flow weir is given by the formula devised by Babbitt.

$$L = 7.6 \times 10^{-3} V D \log \frac{h_1}{h_2}$$

Where L = the required length in m
 V = the velocity of approach in mps
 D = the dia of the sewer in mm and
 h_1 and h_2 = the heads in m above the crest of the weir upstream and downstream.

The formula is limited to conditions in which the weir is placed in the side of a circular pipe at a distance above the bottom, greater than $d/4$ and less than $d/2$ where 'd' is the diameter of the pipe and the edge of the weir is sharp and parallel to the invert of the channel. Its usefulness is limited in that it was devised for pipes between 450 and 600mm in dia and where the depth of flow above the weir should not exceed $3d/4$.

4.7.2 Leaping Weir

A leaping weir is formed by a gap in the invert of a sewer through which the dry-weather flow falls and over which a portion of all of the storm leaps. Leaping weirs have the advantage of operating as regulators without moving parts, but they offer the disadvantage of concentrating grit in the low flow channel. Some formulae based in empirical findings are available for design of leaping weirs. However, from practical considerations, it is desirable to design the weirs with moving crests to make the opening adjustable as indicated in Figure 4.8.

4.7.3 Float Actuated Gates and Valves

Control of the flow in sewers can also be regulated by means of automatic mechanical regulators. These are actuated by the water level in the sump interconnected to the sewers. These regulators involve moving parts which are actuated by the varying depths of flow in the sewers. They require periodic inspection and maintenance.

4.8 FLAP GATES AND FLOOD GATES

Flap gates or backwater gates are installed at or near sewer outlets to prevent backflow of water during high tide or at high stages in the receiving stream. Such gates should be designed so that the flap should open at a very small head differential. With a properly operated flap gate it is possible to continue to pump a quantity equivalent to the sanitary sewage flow from the combined sewer to the treatment plant even though flood conditions prevail in the stream at the sewer outlet.

In case of a sea and estuary outfall, the outfall sewer should be able to discharge at full rate when the water level in the estuary or sea is $\frac{3}{4}$ th the mean annual tide level. Adequate storage to prevent backflow into the system due to the closure of these gates at the time of high tides is also necessary if pumping is to be avoided. To control the flow from the storage tank, flood gate or penstocks are provided which can be opened and closed quickly at the predetermined states of tide. The gates are generally electrically operated and are controlled by a lunar clock.

Many flap or back water gates are rectangular and may consist of wooden planks. Circular or rectangular metallic gates are commercially available. Flap gates may be of various metals or alloys as required by the design conditions.

Flap gates are usually hinged by a link-type arrangement that makes it possible for the gate shutter to get seated more firmly. Hinge pins, linkages and links should be of corrosion resistant material.

There should be a screen chamber to arrest floating undesirables on the upstream side of the flap gate.

The maintenance of flap gates requires regular inspection and removal of debris from the pipe and outlet chamber, lubrication of hinge pins and cleaning of seating surfaces.

4.9 MEASURING DEVICES

This along with measurement of flow has been discussed in detail in Chapter 25.

4.10 SEWER VENTILATORS

In a modern, well designed sewerage system, there is no need to provide ventilation on such elaborate scale considered necessary in the past, specially with the present day policy to omit intercepting traps in house connections. The ventilating columns are not necessary where intercepting traps are not provided. It is necessary however, to make provision for the escape of air to take care of the exigencies of full flow and also to keep the sewage as fresh as possible specially in outfall sewers. In case of storm sewers this can be done by providing ventilating manhole covers.

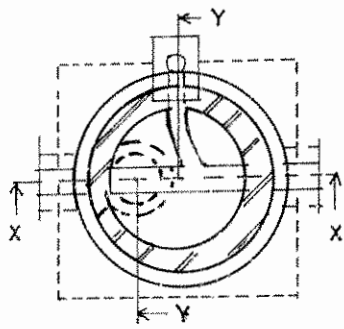

SECTIONAL PLAN ZZ

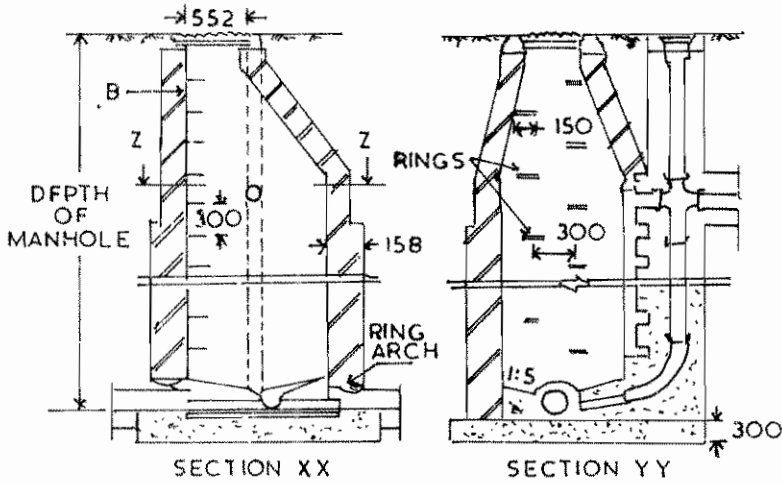

TYPICAL ILLUSTRATION OF DROP MANHOLE
(ALL DIMENSIONS IN MILLIMETRES)

FIG. 4-6

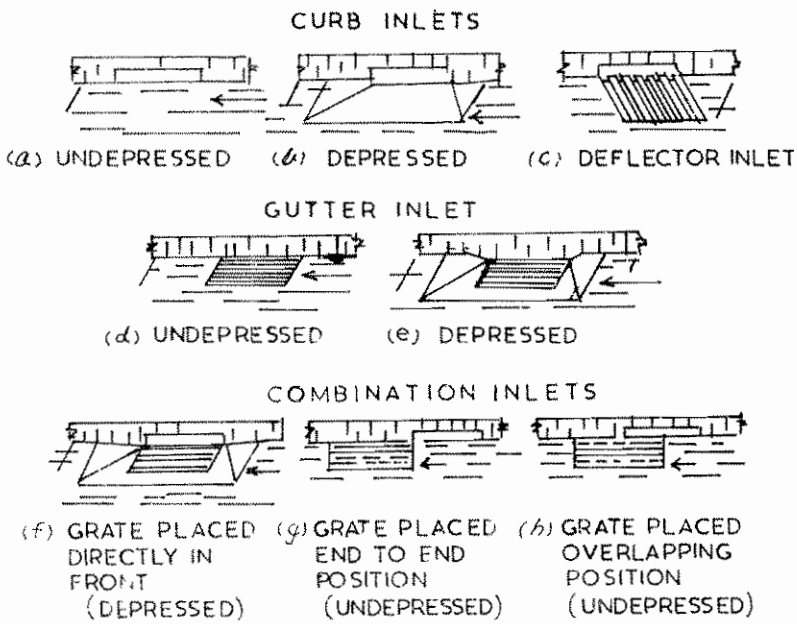
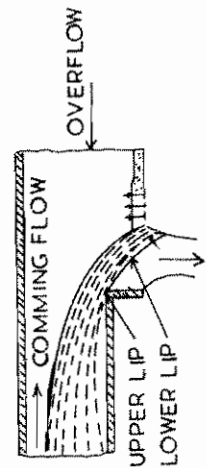

FIG. 4-7



LEAPING WEIR
FIG. 4-8

CHAPTER 5

MATERIALS FOR SEWER CONSTRUCTION**5.1 INTRODUCTION**

Factors influencing the selection of materials for sewer construction are flow characteristics, availability in the sizes required including fittings and ease of handling and installation, water tightness and simplicity of assembly, physical strength, resistance to acids, alkalies, gases, solvents etc., resistance to scour, durability and cost including handling and installation.

No single material will meet all the conditions that may be encountered in sewer design. Selection should be made for the particular application and different materials may be selected for parts of a single project.

5.2 TYPES OF MATERIAL**5.2.1 Brick**

Brickwork is used for construction of sewers, particularly for larger diameters. Many old brick sewers are still in use, the failures are mainly due to the disintegration of the bricks or the mortar joints. Because of the comparatively higher cost, larger space requirement, slower progress of work and other factors, brick is now used for sewer construction only in special cases. The advantage of brick sewers is that these could be constructed to any required shape and size.

Brick sewers shall have cement concrete or stone for invert and 12.5mm thick cement plaster with neat finish for the remaining surface. To prevent ground water infiltration, it is desirable to plaster the outside surface. Under special conditions protections against corrosion may be necessary.

5.2.2 Concrete

Concrete pipes may be manufactured to any reasonable strength required by varying the wall thickness and the percentage of reinforcement and shape of the reinforcing cage. A number of jointing methods are available depending on the tightness required and the operating pressure within the sewer line.

The advantages of concrete pipes are the relative ease with which the required strength may be provided, feasibility of adopting a wide range of pipe sizes and the rapidity with which the trench may be opened and backfilled.

However, these pipes are subject to corrosion where acid discharges are carried in the sewer or where velocities are not sufficient to prevent septic conditions or where the soil is highly acidic or contains excessive sulphates. Protective linings or coatings as discussed in 22.2.5.2 should be used inside and outside where excessive corrosion is likely to occur. Only high alumina cement concrete should be used when it is exposed to corrosive sewage or industrial wastes. When specifying concrete pipe, the pipe diameter, class or strength, the method of jointing and the type of protective coating and lining, if any, should be stipulated. Structural requirements of RCC and other pipes are discussed in 6.1.

5.2.2.1 PRECAST CONCRETE

Precast concrete pipes can be either plain or reinforced. Plain cement concrete pipes are used in sewerage systems on a limited scale only and generally reinforced concrete pipes are used. Non pressure pipes are used for gravity flow and pressure pipes are used for force mains, submerged outfalls, inverted siphons and for gravity sewers where absolute watertight joints are required. Non-pressure pipes used for the construction of sewers and culverts shall conform to IS:458-1988. Certain heavy duty pipes which are not specified in IS:458 should conform to other approved standards.

5.2.2.2 CAST-IN-SITU REINFORCED CONCRETE

Cast-in-situ reinforced concrete sewers are constructed where they are more economical, or when non-standard sections are required, or when a special shape is required or when the headroom and working space are limited. The sewer shape should be of an economic design, easy to construct and maintain and should have good hydraulic characteristics. Wide flat culvert bottoms should be provided with "Vee", of atleast 15cm depth in the centre. All formwork for concrete sewers should be unyielding and tight and should produce a smooth sewer interior. Collapsible steel forms will produce the desirable sewer surface and may be used when the sewer size and length justify the expense.

Reinforcement steel, concrete aggregates, cement and sand should conform to Indian Standard Specifications. It is desirable to specify a minimum clear cover of 50mm over reinforcement steel and a minimum slump consistent with workability should be used for obtaining a dense concrete structure free of voids. The distance for chuting concrete should be kept to a minimum to avoid segregation and the vibrating of concrete done by approved mechanical vibrators. Air entraining cement or plasticizing agents may be used to improve workability and ensure a denser concrete. Concrete should conform to IS: 456-1978.

5.2.3 Stoneware or Vitrified Clay

Salt glazed stoneware pipes are manufactured in sizes 80mm to 1000mm in dia but sizes greater than 380mm dia are not generally used because of economic considerations. Specifications for the AA and A classes are identical except that in the case of Class AA pipes, 100% hydraulic testing has to be carried out at the manufacturing stage while in the case of Class A only 5% of the pipes are tested hydraulically (IS:651-1971). The lengths of vitrified clay pipes are 60cm, 75cm and 90cm, the preference being for the longer pipes for obvious reasons. Standard pipe fittings of vitrified clay are available to meet most requirements. When specifying vitrified clay pipes, the pipe diameter, class or strength, the method of jointing and the type of protective coating or lining if any, should be stipulated.

The resistance of vitrified clay pipes to corrosion from most acids and to erosion due to grit and high velocities gives it an advantage over other pipe materials in handling those wastes which contain high acid concentrations. Though a minimum crushing strength of 1600Kg/m is usually adopted for all sizes manufactured presently, vitrified clay pipes of crushing strength 2800Kg/m and over are manufactured in sizes upto 750mm dia in other countries. The strength of vitrified clay pipes often necessitates special bedding or concrete cradling to improve field supporting strength.

5.2.4 Asbestos Cement

For sewerage works, Asbestos cement pipes are usually used in sizes ranging from 80mm to 1000mm in dia (IS:1592-1970).

Some of the advantages of A.C.pipes are:

Non-corrosiveness to most natural soil conditions, freedom from electrolytic corrosion, good flow characteristics, light weight, ease in cutting, drilling, threading and fitting with G.I.Specials, allowance of greater deflection upto 12 degrees with mechanical joints, ease of handling, tight joints, and quick laying and backfilling.

A.C. pipes cannot, however, stand high superimposed loads and may be broken easily. They are subject to corrosion by acids, highly septic sewage and by highly acidic or high sulphate soils. Protective measures as outlined in 22.2.5 shall be provided in such cases. While using A.C. pipes strict enforcement of approved bedding practices will reduce possibility of flexure failure. Where grit is present, high velocities such as those encountered on steep grades may cause erosion.

5.2.5 Iron and Steel

5.2.5.1 CAST IRON

Cast iron pipes with a variety of jointing methods are used for pressure sewers, sewers above ground surface, submerged outfalls, piping in sewage treatment plants and occasionally on gravity sewers where absolutely water tight joints are essential or where special considerations require their use. I.S:1536-1989 and I.S:1537-1976 give the specifications for spun and vertically cast pipes respectively.

The advantage of cast iron pipes are long laying lengths with tight joints, ability when properly designed to withstand relatively high internal pressure and external loads and corrosion resistance in most natural soils. They are however subject to corrosion by acids or highly septic sewage and acidic soils.

Whenever it is necessary to deflect pipes from a straight line either in the horizontal or in the vertical plane, the amount of deflection allowed should not normally exceed 2.5 degrees for lead caulked joints and for mechanical joints, the deflection should be limited to 5 degrees for 80 to 300mm dia, 4 degrees for 350 to 400mm dia and 3 degrees upto 750mm dia pipes.

When specifying cast iron pipe, it is necessary to give the pipe class, the type of joint, the type of lining and the type of exterior coating. Necessary care should be taken during transport and handling of the pipes against breakage and cracks.

5.2.5.2 STEEL

Pressure sewer mains, under water river crossings, bridge crossings, necessary connections for pumping stations, self supporting spans, railway crossing and penstocks are some of the situations where steel pipes are preferred.

Steel pipes can withstand internal pressure, impact load and vibrations much better than C.I. pipe. They are more ductile and withstand water hammer better.

The disadvantage of steel pipe is that it cannot withstand high external load. Further, the main is likely to collapse when it is subjected to negative pressure.

Steel pipes are susceptible to various types of corrosion. Therefore steel pipes should not be used for partially full sewers. A thorough soil survey is necessary all along the alignment where steel pipes are proposed. Steel pipes should be protected against both internal and external corrosion.

Steel pipes should conform to IS:3589. Electrically welded Steel pipes (200mm to 2000mm) for gas, water and sewage and laying should conform to IS:5822.

5.2.5.3 DUCTILE IRON PIPES

Ductile Iron Pipes recently developed are also finding application in sewage conveyance systems. For further details reference may be made to IS:12288-1987.

5.2.6 Plastic Pipes

5.2.6.1 GENERAL

Plastic pipes are produced by extrusion process followed by calibration to ensure maintenance of accurate internal dia with smooth internal bores. These pipes generally come in lengths of 6 metres. A wide range of injection moulded fittings, including tees, elbows, reducers, caps, pipe saddles, inserts and threaded adapters for pipe sizes upto 150mm are available.

5.2.6.2 PVC PIPES

The Chief advantages of PVC are:

- Resistance to corrosion
- Light Weight
- Toughness
- Rigidity
- Economical in laying, jointing and maintenance
- Ease of fabrication

Rigid PVC pipes weigh only 1/5 of conventional steel pipes of comparable sizes. PVC pipes are available for drainage works in sizes of outer dia., 75,90,110,140,160,250,290,315mm at working pressures of 2.5, 4, 6 and 10 kg/cm². PVC pipes are not very suitable for sewerage works. Pipes stored should not exceed three layers and should be so stacked as to prevent movement. It is also recommended not to store one pipe inside another.

5.2.6.3 HIGH DENSITY POLYETHYLENE (HDPE) PIPES

Among the recent developments, is the use of High Density Polyethylene pipes in special situations. These pipes are not brittle like AC and other pipes and hence a hard fall at the time of loading, unloading, handling etc. cannot do any harm to it. HDPE pipes upto 630mm dia can be joined with detachable joints and can be detached at the time of shifting the pipe line from one place to another. HDPE pipes can be joined also by welding.

For further details of PVC and HDPE pipes, reference may be made to:

- IS : 7834 - 1975, Parts 1 - 8
- IS : 8008 - 1976, Parts 1 - 7
- IS : 7634 - 1975, Parts 1 - 3
- IS : 3076 - 1985
- IS : 4984 - 1987

5.2.7 Glass Fibre Reinforced Plastic Pipes

G.R.P. Pipes are widely used in other countries where corrosion resistant pipes are required at reasonable costs.

GRP can be used as a lining material for conventional pipes which are subject to corrosion. Fibre glass coating can resist external and internal corrosion whether the corrosion mechanism is galvanic or chemical in nature.

5.2.7.1 FIBRE GLASS REINFORCED PLASTIC PIPES (FRP)

Fibre glass reinforced plastic pipe is a matrix or composite of glass fibre, polyester resin and fillers. These pipes possess better strength, durability, high tensile strength, low density and are highly corrosion resistant.

Fibre glass pressure pipes are manufactured in diameters upto 2400mm and length upto 18m. These pipes are now being taken up for manufacture in India.

Standard specifications have been framed by the BIS and for further details of F.R.P.pipes reference may be made to IS: 12709-1989.

5.2.8 Pitch Fibre Pipes

The pitch impregnated fibre pipes are of light weight and have shown their durability in service. The pipes can be easily jointed in any weather condition as internally tapered couplings join the pipes without the use of jointing compound. They are flexible, resistant to heat, freezing and thawing and earth currents which set up electrolytic action. They are also unaffected by acids and other chemicals, water softeners, sewer gases, oils and greases and laundry detergents. They can be cut to required length on the site. Because of the larger lengths, cost of jointing, handling and laying is reduced. These are generally recommended for all drainage uses such as house connection to sewers and septic tanks, farm drainage, down pipes, storm drains, industrial waste drainage etc. These have recently been manufactured in India. These are manufactured in 50, 75, 100, 125, 150, 200 and 225mm nominal diameter and length varies from 1.5m to 3.5m. These pipes are jointed by taper coupling joints or rubber ring joints. The details of the pipes and fittings such as dimensions etc. have been covered in IS:11925-1985.

5.3 JOINTING IN SEWER PIPES

From the consideration of structural requirements, joints may be classified as rigid and flexible joints. Joints such as cement mortar, lead, flanged and welded joints are under the category of rigid joints as they do not withstand any angular rotation. All types of mechanical joints such as rubber gasket joints are flexible as they take rotation to the extent of a few degrees and thus reduce the undue settlement stress. Flexible joints are preferable to rigid joints, particularly with granular bedding.

Chapter 6 of the CPHEEO Manual on Water Supply and Treatment gives the types of joints used for C.I., Steel, AC, concrete and plastic pipes. The socket and spigot type of joint is the most widely used joint for vitrified clay pipes. Internal flush joints have also been occasionally used.

STRUCTURAL DESIGN OF BURIED SEWERS

6.1 INTRODUCTION

The structural design of a sewer is based on the relationship: the supporting strength of the sewer as installed divided by a suitable factor of safety must equal or exceed the load imposed on it by the weight of earth and any superimposed loads.

The essential steps in the design and construction of buried sewers or conduits to provide safe installations are therefore.

- i) determination of the maximum load that will be applied to the pipe based on the trench and backfill conditions and the live loads to be encountered
- ii) computation of the safe load carrying capacity of the pipe when installed and bedded in the manner to be specified using a suitable factor of safety and making certain the design supporting strength thus obtained is greater than the maximum load to be applied
- iii) Specifying the maximum trench widths to be permitted, the type of pipe bedding to be obtained and the manner in which the backfill is to be made in accordance with the conditions used for the design
- iv) checking each pipe for structural defects before installation and making sure that only sound pipes are installed and
- v) ensuring by adequate inspection and engineering supervision that all trench widths, subgrade work, bedding, pipe laying and backfilling are in accordance with design assumptions as set forth in the project specifications.

Proper design and adequate specifications alone are not enough to ensure protection from dangerous or destructive overloading of pipe. Effective value of these depends on the degree to which the design assumptions are realised in actual construction. For this reason thorough and competent inspection is necessary to ensure that the installation conforms to the design requirements.

6.2 TYPE OF LOADS

In a buried sewer, stresses are induced by external loads and also by internal pressure in case of a pressure main. The stress due to external loads is of utmost importance and may be the only one considered in the design. Besides, if the sewer is exposed to sunlight, temperature stresses induced may be considerable and these will have to be taken into consideration particularly in case of metallic pipes. The external loads are of two categories viz. load due to backfill material known as backfill load and superimposed load which again is of two types viz. concentrated load and distributed load. Moving loads may be considered as equivalent to uniformly distributed load. Sewer lines are mostly constructed of stoneware, concrete or cast iron which are considered as rigid pipes (while steel pipes, if used, are not considered as rigid pipes). The flexibility of the pipe affects the load imposed on the pipe and the stresses induced in it.

6.3 LOADS ON CONDUITS DUE TO BACKFILL

Methods for determining the vertical load on buried conduits due to gravity earth forces in all commonly encountered conditions as developed by A. Marston are generally accepted as the most suitable and reliable for computation. Theoretically stated, the load on a buried conduit is equal to the weight of the prism of earth directly over the conduit, called the interior prism of earth plus or minus the frictional shearing forces transferred to the prism by the adjacent prism of earth.

The considerations are:

- a) the calculated load due to the backfill is the load which will develop when ultimate settlement has taken place
- b) the magnitude of the lateral pressure causing the shearing force is computed by Rankine's theory and
- c) there is negligible cohesion except for tunnel conditions.

The general form of Marston's formula is

$$W = C.w.B^2 \quad (6.1)$$

Where W = vertical load in kgs per meter length acting on the conduit due to gravity earth loads

w = unit weight of earth, kg/m^3

B = width of trench or conduit in meters depending upon the type of installation conditions

C = dimensionless co-efficient that measures the effect of :

- a) ratio of height of fill to width of trench or conduit
- b) shearing forces between interior and adjacent earth prisms and
- c) direction and amount of relative settlement between interior and adjacent earth prisms for embankment conditions.

6.3.1 Types of Installation or Construction Conditions

The accepted types of installation or construction conditions are shown in Fig.6.1. There are three classifications for the construction conditions viz.

- 1) embankment condition
- 2) trench condition and
- 3) tunnel condition.

Embankment condition prevails when the conduit is covered with fill above the original ground surface or when a trench in undisturbed ground is so wide that trench wall friction does not affect the load on the pipe. The embankment condition is further classified, depending upon the position of the top of conduit in relation to the original ground surface, as

- i) positive projecting condition
- ii) zero projecting condition
- iii) negative projecting condition and
- iv) imperfect trench condition.

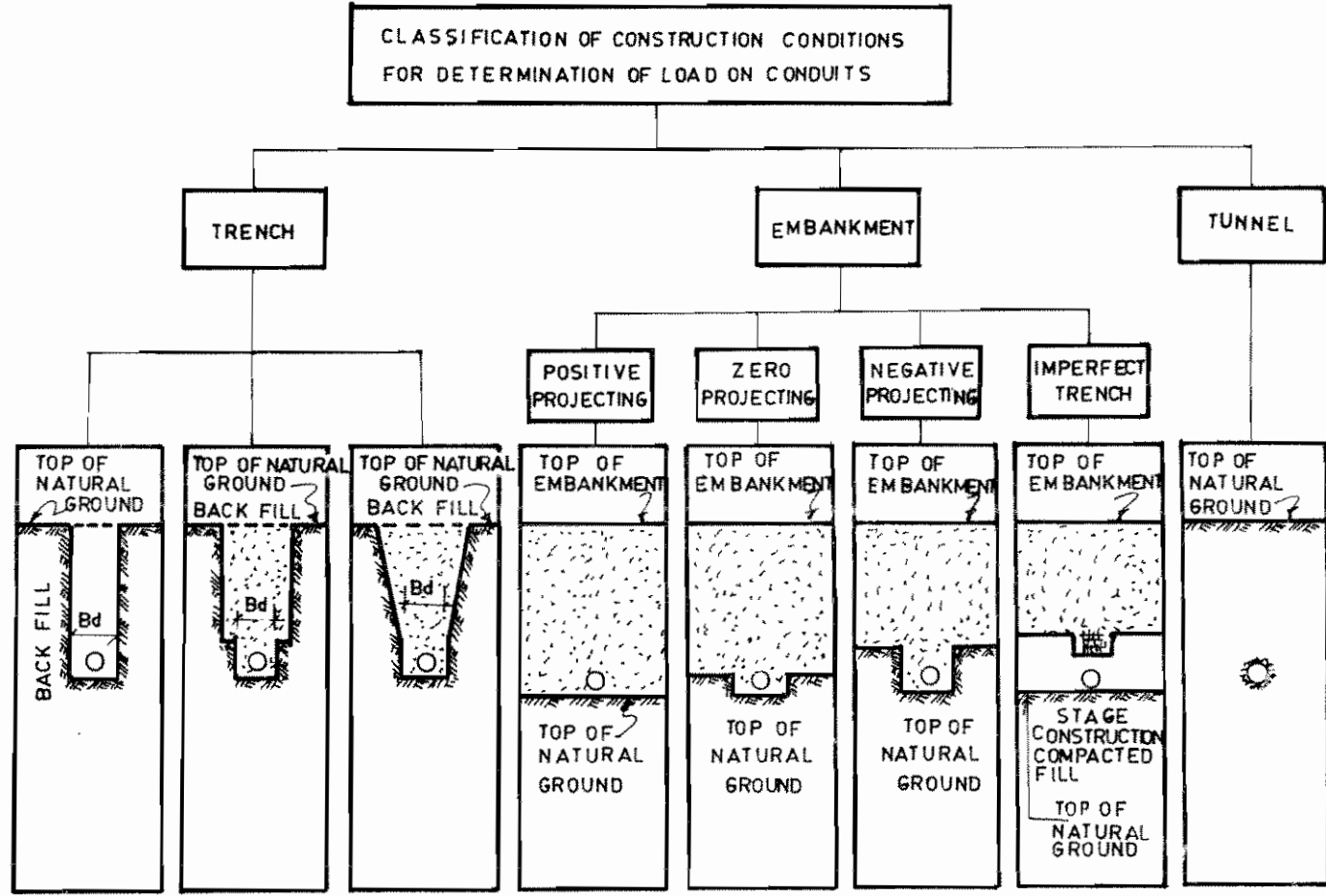

NOTE : NORMAL GROUND WATER LEVEL WITH REFERENCE TO THE INVERT LEVEL IS TO BE TAKEN NOTE OF IN THE DESIGN.

FIG. 6.1 : CLASSIFICATION OF CONSTRUCTION CONDITIONS

Trench condition exists when the pipe or conduit is installed in a relatively narrow trench (not wider than twice the external diameter of the pipe) cut in undisturbed soil and then covered with earth backfill upto the original ground surface.

Tunnel condition exists when the sewer is placed by means of jacking or tunneling.

6.3.2 Loads for Different Conditions

6.3.2.1 EMBANKMENT OR PROJECTING CONDUIT CONDITION

a) *Positive Projecting Conduit*

A conduit is said to be laid as a positive projecting conduit when the top of the conduit is projecting above the natural ground into the overlying embankment (figure 6.2).

i) Load Producing Forces

The load on the positive projecting conduit is equal to the weight of the prism of soil directly above the structure plus or minus vertical shearing forces which act in a vertical plane extending upward into the embankment from the sides of the conduit. These vertical shearing forces ordinarily do not extend to the top of the embankment but terminate in a horizontal plane at some elevation above the top of the conduit known as the plane of equal settlement as shown in Fig.6.2 which also shows the elements of settlement ratios.

Settlement ratio $r_{sd} = \frac{\text{Settlement of critical plane} - \text{settlement of top of conduit}}{\text{Compression of height of column H of embankment}}$

$$r_{sd} = \frac{(S_m + S_g) - (S_i + d_c)}{S_m} \quad (6.2)$$

- where H = height of top of conduit above adjacent natural ground surface (initial) or the bottom of a wide trench
- = p. B_c where p is the projection ratios and B_c is outside width of conduit
- S_m = compression column of height H of embankment
- S_g = Settlement of natural ground adjacent to the conduit
- S_i = settlement of the bottom of conduit and
- d_c = deflection of conduit or shortening of its vertical height under load.

When $(S_m + S_g)$ is greater than $(S_i + d_c)$, r_{sd} is positive i.e. the shearing forces act downwards. Therefore the load on conduit is equal to weight of critical prism plus shear force.

When $(S_m + S_g)$ is less than $(S_i + d_c)$, r_{sd} is negative and the shear force acts in the upward direction.

The settlement ratio r_{sd} therefore, indicates the direction and magnitude of the relative settlement of the prism of earth directly above and adjoining the conduit.

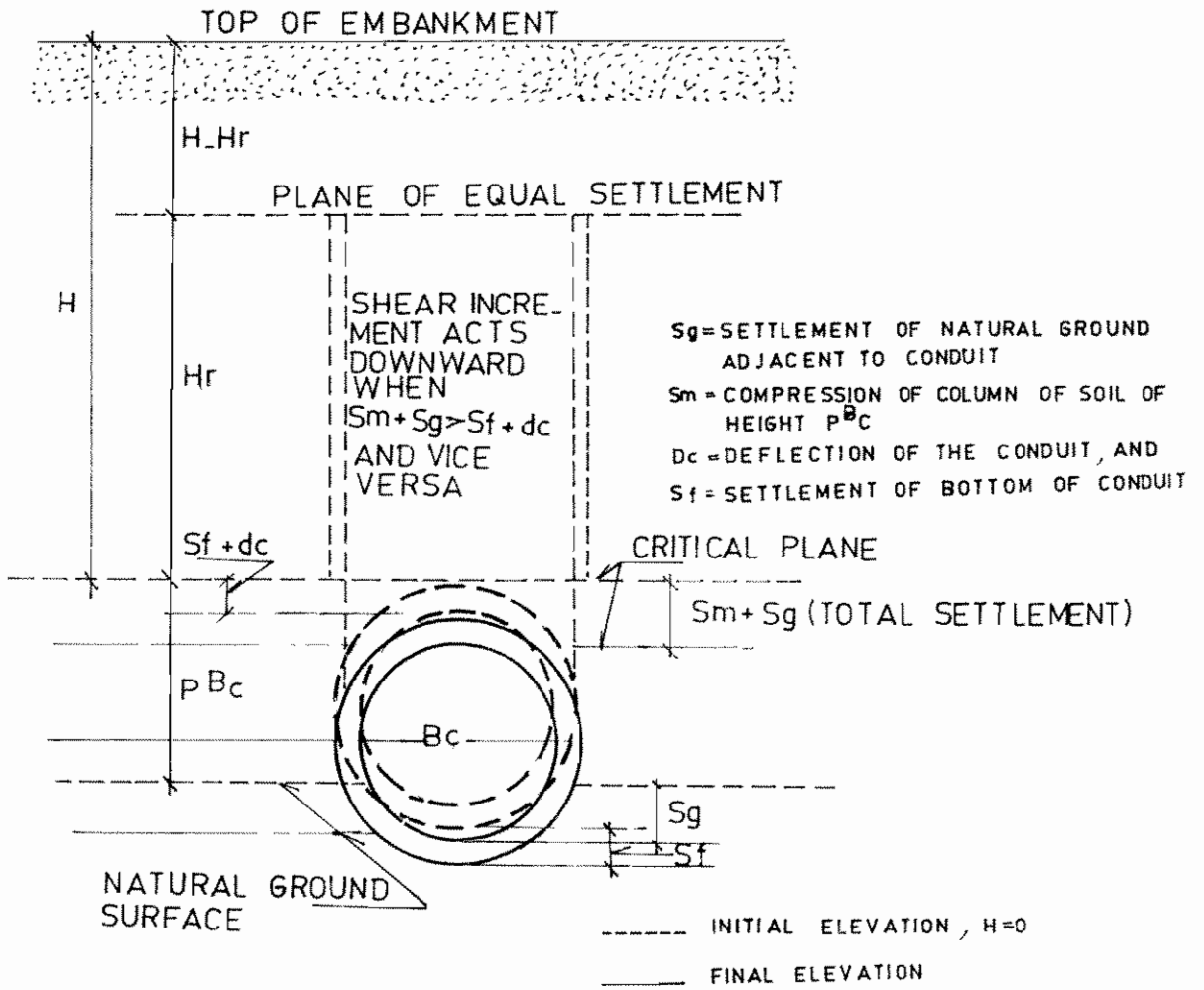

FIG.6.2: SETTLEMENTS THAT INFLUENCE LOADS ON POSITIVE PROJECTING CONDUITS.

The product r_{sd} multiplied by p gives the relative height of plane of equal settlement and hence of the magnitude of the shear component of the load.

When $r_{sd} \times p = 0$, the plane of equal settlement coincides with the critical plane and there are no shearing forces and the load is equal to the weight of the central prism. It is not practicable to predetermine this r_{sd} value. However, recommended design values based on actual experience are given in Table 6.1

TABLE 6.1
RECOMMENDED DESIGN VALUES OF SETTLEMENT RATIOS

Type of Conduit	Type of Soil	Settlement Ratio (r_{sd})
1. Rigid	Rock or unyielding foundation	+ 1.0
2. Rigid	Ordinary foundation	+ 0.5 to + 0.8
3. Rigid	Yielding foundation	0 to + 0.5
4. Rigid	Negative projecting installation	- 0.3 to - 0.5
5. Flexible	Poorly compacted sidefill	- 0.4 to 0
6. Flexible	Well compacted sidefill	0

ii) Computation of Loads

Marston's formula for positive projecting conduits (both rigid and flexible) is as follows:

$$W_c = C_c w B_c^2 \quad (6.2)$$

Where

- W_c = load on conduit in kg/m
- w = unit weight of backfill material in kg/m^3
- B_c = outside width of conduit in m, and
- C_c = load coefficient, which is a function of the product of the projection ratio and the settlement ratio and ratio of the height of fill above the top of the conduit to the outside width of the conduit (H/B). It is also influenced by the coefficient of internal friction of the backfill material and the Rankine's ratio of lateral pressure to vertical pressure K_v . Suggested values for K_v for positive and negative settlement ratios are 0.19 and 0.13 respectively.

The value of C_c can be obtained from Fig. 6.3

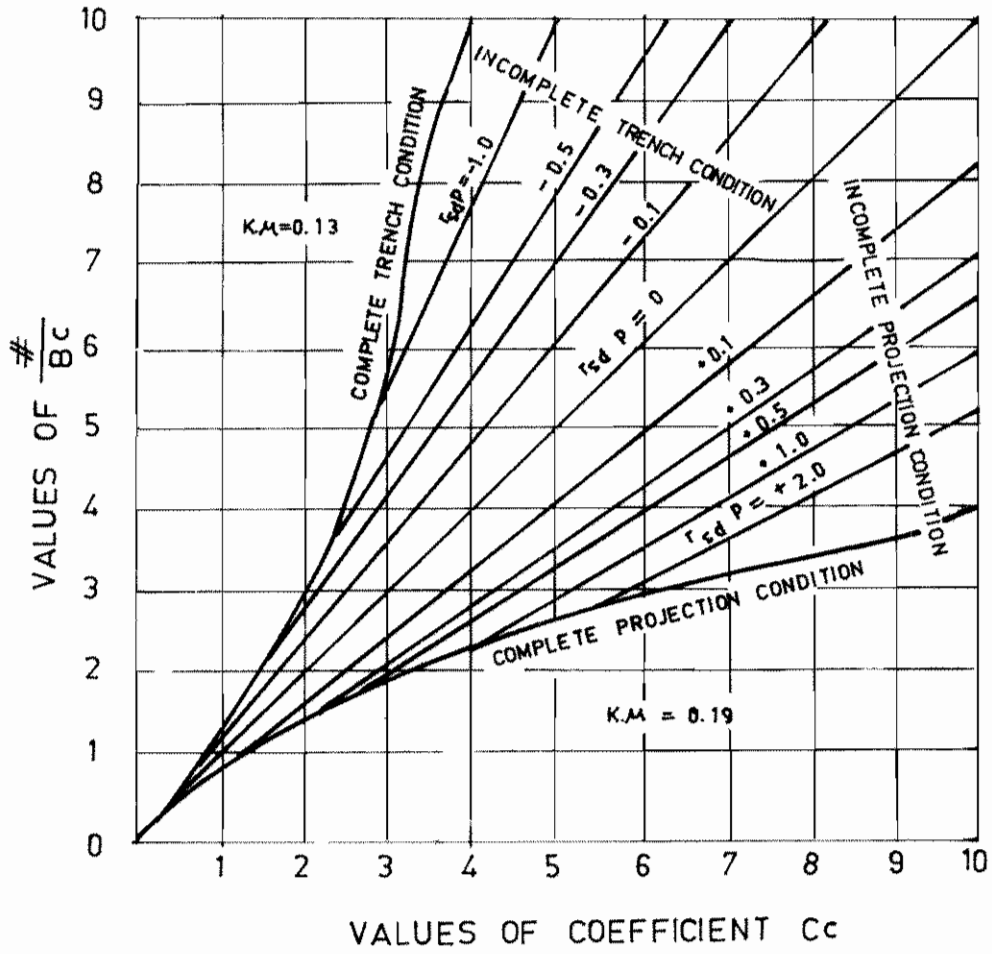

FIG. 6.3 : DIAGRAM FOR COEFFICIENT C_c FOR POSITIVE PROJECTING CONDUITS

b) Negative Projecting Conduit

A conduit is said to be laid in a negative projecting condition when it is laid in a trench which is narrow with respect to the size of pipe and shallow with respect to depth of cover and the native material of the trench is of sufficient strength that the trench shape can be maintained dependably during the placing of the embankment, the top of the conduit being below the natural ground surface and the trench refilled with loose material and the embankment constructed above (Fig.6.4). The prism of soil above the conduit, being loose and greater in depth compared to the adjoining embankment, will settle more than the prism over the adjoining areas thus generating upward shear forces which relieve or reduce the load on the conduit.

i) Computation of Loads

Marston's formula for negative projecting conduits is given by

$$W_c = C_n w B_d^2 \quad (6.3)$$

Where

W_c = load on the conduit in Kg/m

B_d = width of trench in m

w = the unit weight of soil in kg/m^3 and

C_n = load coefficient, which is a function of the ratio (H/B_d) of the height of fill and the width of trench equal to the projection ratio p (Vertical distance from the firm ground surface down to the top of the conduit/width of the trench) and the settlement ratio r_{sd} given by the expression.

$$r_{sd} = \frac{\text{settlement of natural ground} - \text{settlement of critical plane}}{\text{compression of the backfill within the height } p B_d}$$

$$= \frac{S_n - (S_c + S_d + d_c)}{S_d} \quad (6.4)$$

Values of C_n for various values of H/B_d , r_{sd} , and p are given in Fig.6.5

Exact determination of the settlement ratio is very difficult.

Recommended value of r_{sd} is -0.3 for design purposes. Elements of settlement ratios are shown in Fig.6.6.

(c) Imperfect Trench Conduits

An imperfect trench conduit is employed to minimise the load on a conduit under embankments of unusual heights. The conduit is first installed as a positive projecting conduit. The embankment is then built up to some height above the top and thoroughly compacted as it is placed. A trench of the same width as the conduit is excavated directly over it down to or near its top. This trench is refilled with loose compressible material and the balance of the embankment completed in a normal manner (figure 6.7).

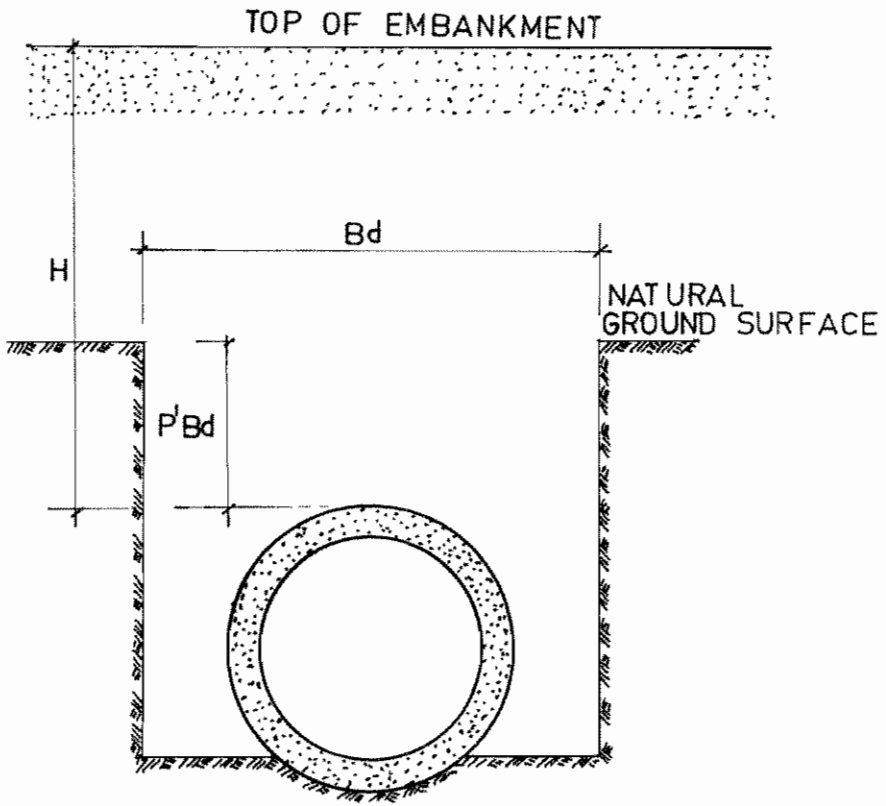

FIG.6.4: NEGATIVE PROJECTING CONDUIT

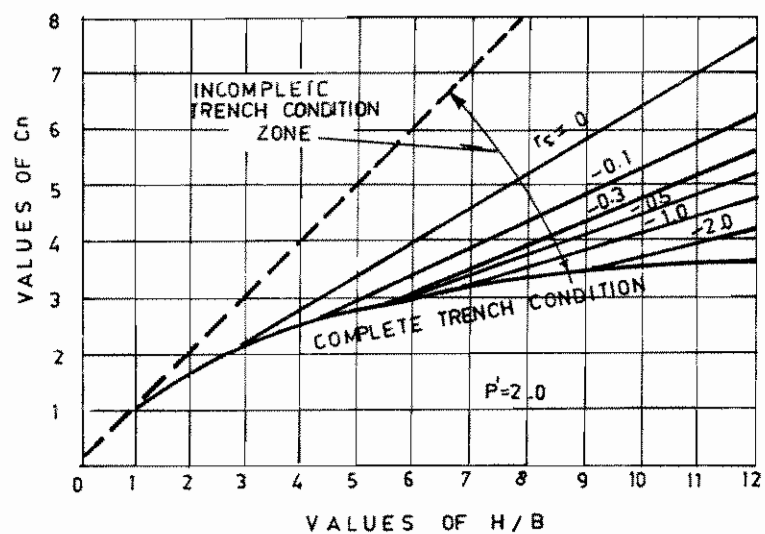
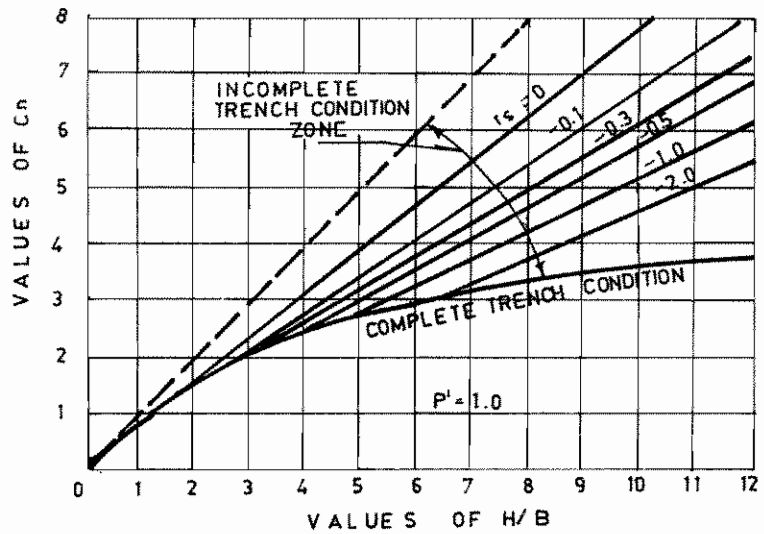
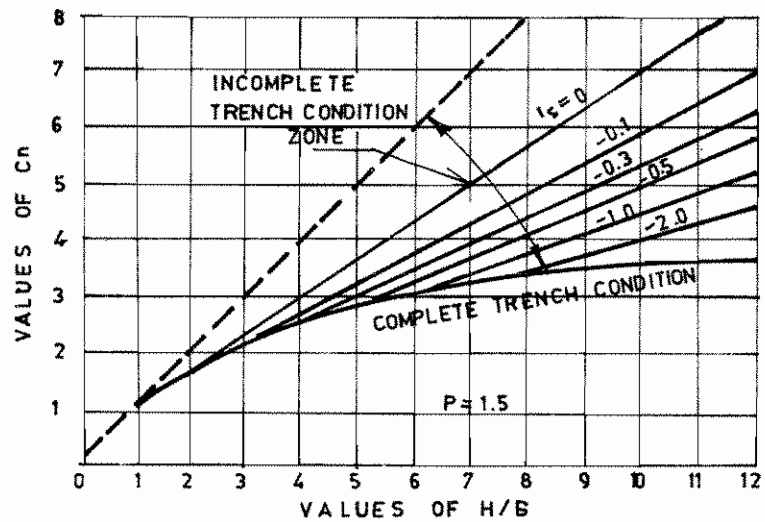
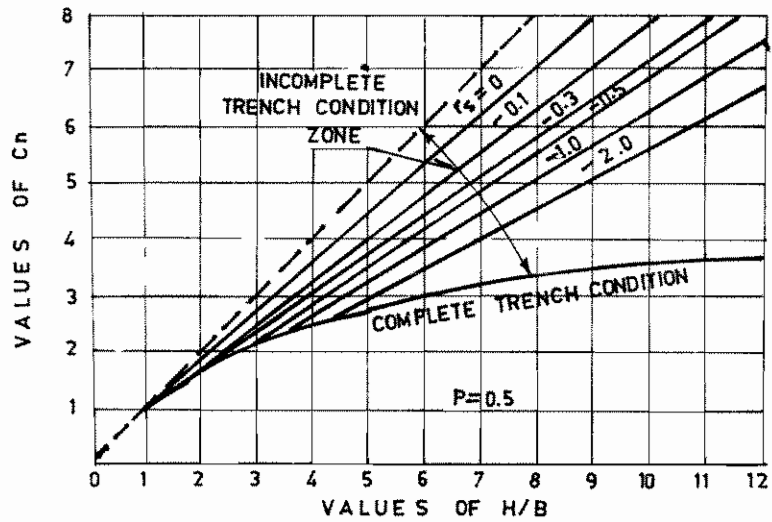

FIG.6.5: COEFFICIENT C_n FOR NEGATIVE PROJECTING CONDUITS AND IMPERFECT TRENCH CONDITIONS

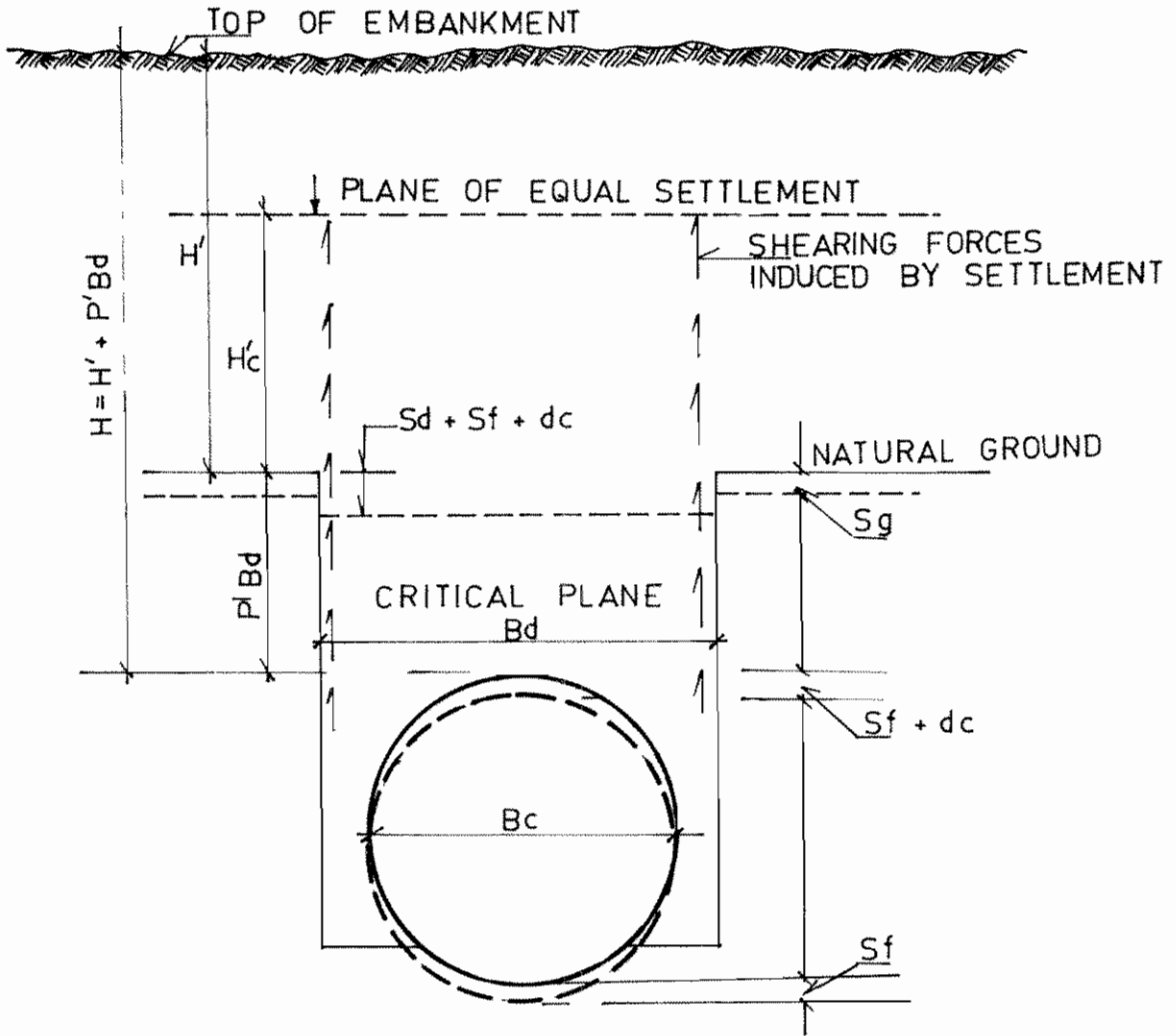

FIG. 6.6: SETTLEMENTS THAT INFLUENCE LOADS ON NEGATIVE PROJECTING CONDUITS

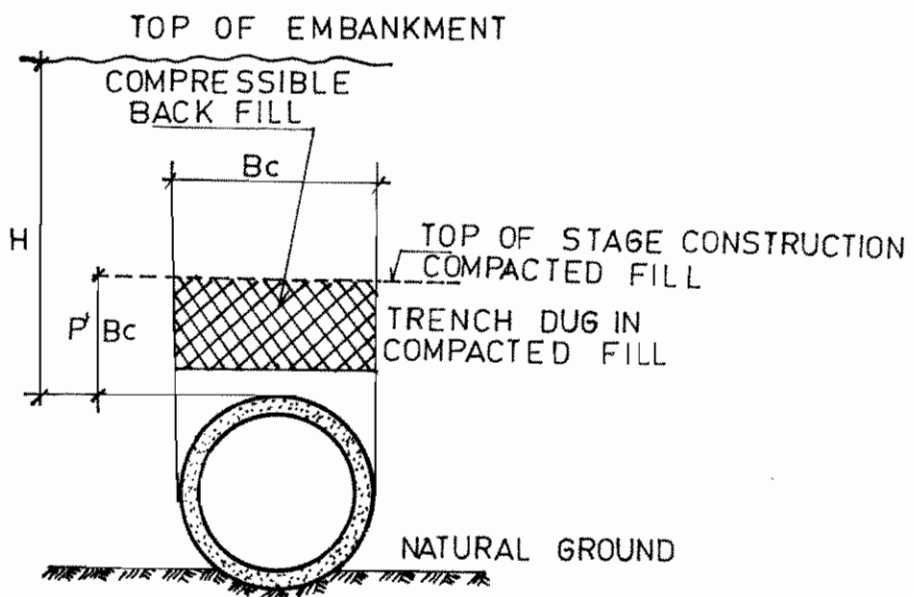

FIG. 6.7: IMPERFECT TRENCH CONDITIONS

The Marston's formula for this installation condition is again given by

$$W_c = C_n w B_c^2 \quad (6.5)$$

The values of C_n in this case also may be obtained from Fig.6.5 for negative projecting conduits taking $B_c = B_d$ on the assumption that the trench fill is no wider than the pipe.

6.3.2.2 TRENCH CONDITION

Generally sewers are laid in ditches or trenches by excavation in natural or undisturbed soil and then covered by refilling the trench to the original ground level.

a) *Load Producing Forces*

The vertical dead load to which a conduit is subjected under trench conditions is the resultant of two major forces. The first component is the weight of the prism of soil within the trench and above the top of the pipe and the second is due to the friction or shearing forces generated between the prism of soil in the trench and the sides of the trench produced by settlement of backfill. The resultant load on the horizontal plane at the top of the pipe within the trench is equal to the weight of the backfill minus these upward shearing forces as shown in Fig.6.8.

b) *Computation of Loads*

The load on rigid conduits in trench condition is given by the Marston's formula in the form

$$W_t = C_d w B_d^2 \quad (6.6)$$

W_t = the load on the pipe in kg per linear metre

w = the unit weight of backfill soil in kg/m^3

B_d = the width of trench at the top of the pipe in m and

C_d = the load coefficient which is a function of a ratio of height of fill to width of trench (H/B_d) and of the friction coefficient between the backfill and the sides of the trench.

Weights of common filling materials (w) and values of C_d for common soil conditions encountered are given in Tables 6.2 and 6.3 respectively.

TABLE 6.2
WEIGHTS OF COMMON FILLING MATERIAL

Materials	Weight (Kg/m^3)
Dry Sand	1 600
Ordinary (Damp Sand)	1 840
Wet Sand	1 920
Damp Clay	1 920
Saturated Clay	2 080
Saturated Top Soil	1 840
Sand and Damp Soil	1 600

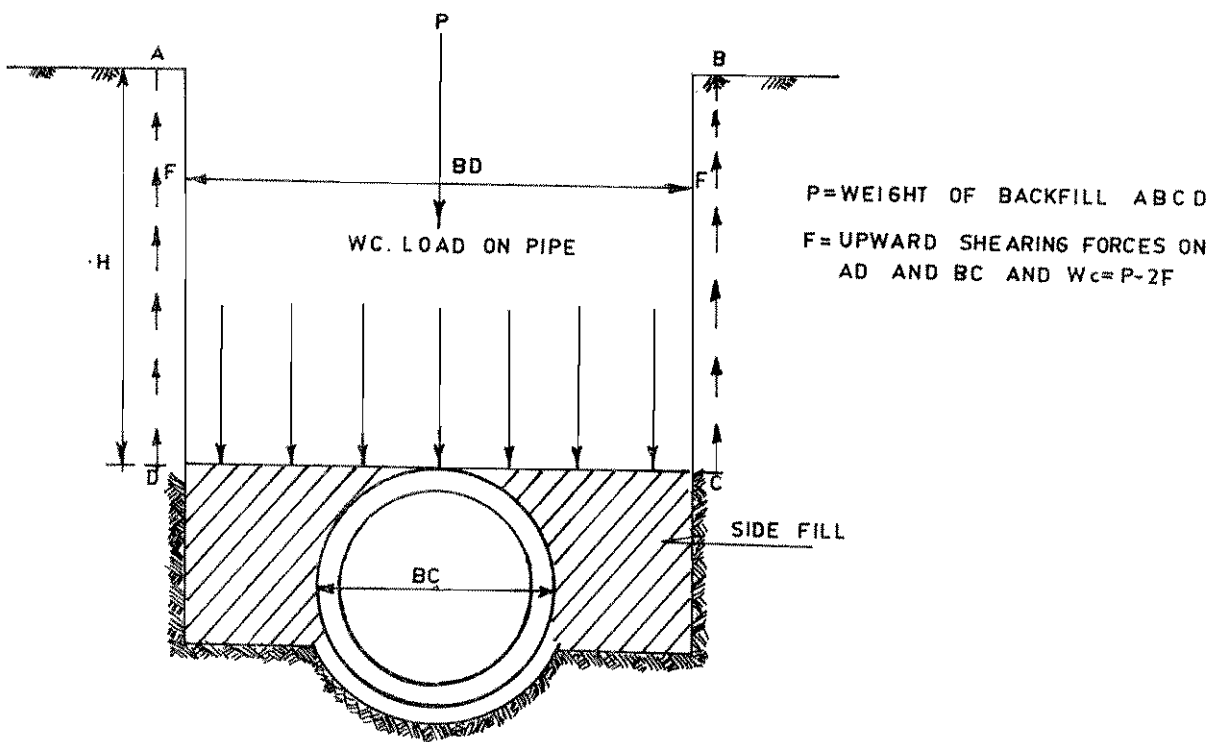

FIG. 6.8: LOAD PRODUCING FORCES

Equation (6.6) gives the total vertical load due to backfill in the horizontal plane at the top of the conduit as shown in Figure 6.8 if the pipe is rigid. For flexible conduits, the formula may be modified as

$$W_c = C_o w B_c B_s \quad (6.7)$$

Where B_c is the outside width of the conduit in m.

c) Influence of Width of Trench

It has been experimentally seen that when the width of trench excavated is not more than twice the external width of the conduit, the assumption made in the trench condition of loading holds good. If the width of the trench goes beyond three times the outside dimension of the conduit, it is necessary to apply the embankment condition of loading. In the transition width from $B_d = 2B_c$ to $B_d = 3B_c$ computation of load by both the procedures will give the same results.

TABLE 6.3
VALUES OF C_o FOR CALCULATING LOADS ON PIPES IN TRENCHES ($W_c = C_o WB^2d$)

Ratio H/E	Safe working Values of C_o				
	Minimum Possible without cohesion	Maximum for Ordinary Sand	Completely Saturated Top Soil	Ordinary maximum for clay	Extreme maximum for clay
0.5	0.455	0.461	0.464	0.469	1.474
1.0	1.010	0.952	0.864	0.881	0.888
1.5	1.140	1.183	1.209	1.242	1.278
2.0	1.295	1.464	1.504	1.560	1.618
2.5	1.406	1.702	1.764	1.836	1.923
3.0	1.780	1.804	1.978	2.083	2.196
3.5	1.923	2.075	2.167	2.296	2.441
4.0	2.041	2.221	2.329	2.487	2.660
4.5	2.158	2.344	2.469	2.600	2.856
5.0	2.219	2.448	2.580	2.788	3.032
5.5	2.286	2.537	2.660	2.926	3.190
6.0	2.340	2.612	2.767	3.038	3.331
6.5	2.388	2.673	2.859	3.117	3.458
7.0	2.423	2.729	2.925	3.223	3.571
7.5	2.454	2.775	2.982	3.299	3.673
8.0	2.479	2.814	3.031	3.366	3.764
8.5	2.500	2.847	3.073	3.424	3.845
9.0	2.518	2.875	3.109	3.476	3.918
9.5	2.532	2.898	3.141	3.521	3.983
10.0	2.543	2.918	3.167	3.560	4.042
11.0	2.561	2.950	3.215	3.626	4.141
12.0	2.573	2.972	3.242	3.676	4.221
13.0	2.581	2.989	3.266	3.715	4.285
14.0	2.587	3.001	3.283	3.745	4.336
15.0	2.591	3.009	3.296	3.768	4.378
Very Great	2.599	3.030	3.333	3.846	4.546

$W_c =$	load on pipe in kg per linear metre
$C_d =$	Coefficient
$w =$	Weight of trench filling material in kg/m^3
$B_d =$	Width of trench a little below the top of the pipe in metres.
.	Ratio of height of fill above top of pipe to width of trench a little below the top of the pipe.
-	These values give the loads generally imposed by granular filling materials before tamping or settling.
...	Use these values as safe for all ordinary cases of sand filling.
....	Thoroughly wet. Use these values as safe for all ordinary cases of clay filling.
.....	Completely saturated. Use these values only for extremely unfavourable conditions.

In case of excavations with sloping sides (possible in undeveloped areas), the provision of a sub-trench (Fig.6.9) minimises the load on the pipe by reducing the value of B_d .

6.3.2.3 TUNNEL CONDITION

When the conduit is laid more than 9 to 12 meters deep or when the surface obstructions are such that it is difficult to construct the pipeline by the conventional procedure of excavation and backfilling, it may be more economical to place the conduit by means of tunnelling. The general method in this case is to excavate the tunnel, to support the earth by suitable means and then to lay the conduit. The space between the conduit and the tunnel is finally filled up with compacted earth or concrete grout as indicated in Fig.6.10. If the length of tunnel is short say 6 - 10 meters the entire circular section can be constructed as one unit. For longer tunnels construction may be in segments with refilling proceeding simultaneously.

a) *Load Producing Forces*

The vertical load acting on the tunnel supports and eventually the pipe in the tunnel is the resultant of two major forces viz. the weight of the overhead prism of soil within the width of the tunnel excavation and the shearing forces generated between the interior prisms and the adjacent material due to friction and cohesion of the soil.

b) *Load Computations*

Marston's formula to be used in this case of installation of conduit is given by:

$$W_t = C_1 B (wB + 2C) \quad (6.8)$$

Where

$W_t =$ load on the pipe or tunnel support in Kg/m

$w =$ unit weight of soil above the tunnel in kg/m^3

$B =$ maximum width of the tunnel excavation in m

$C =$ coefficient of cohesion in kg/m^2 and

$C_1 =$ load coefficient which is a function of the ratio (H/B) of the distance from the ground surface to the top of the tunnel to the maximum width of tunnel excavation and of the coefficient of internal friction of the material of the tunnel.

When the coefficient of cohesion is zero, the formula reduces to the same form as in trench condition Eq.(6.6).

Value of C_1 for various values of H/B , and different soil conditions are to be obtained from Fig.6.11.

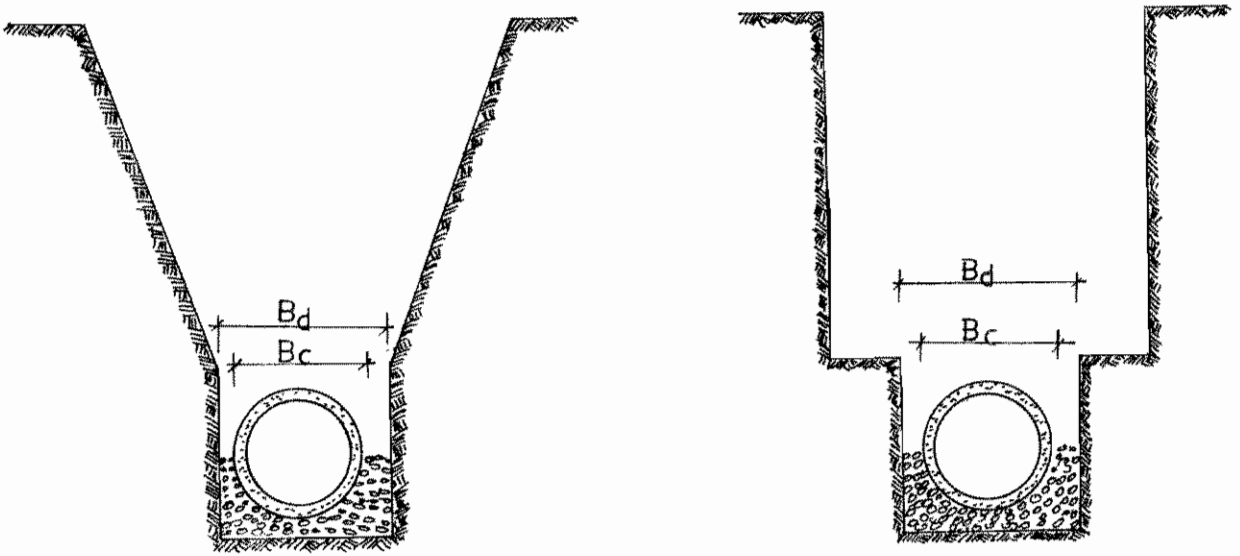

FIG. 6.9 : EXAMPLES OF SUBTRENCH

TOP OF NATURAL GROUND

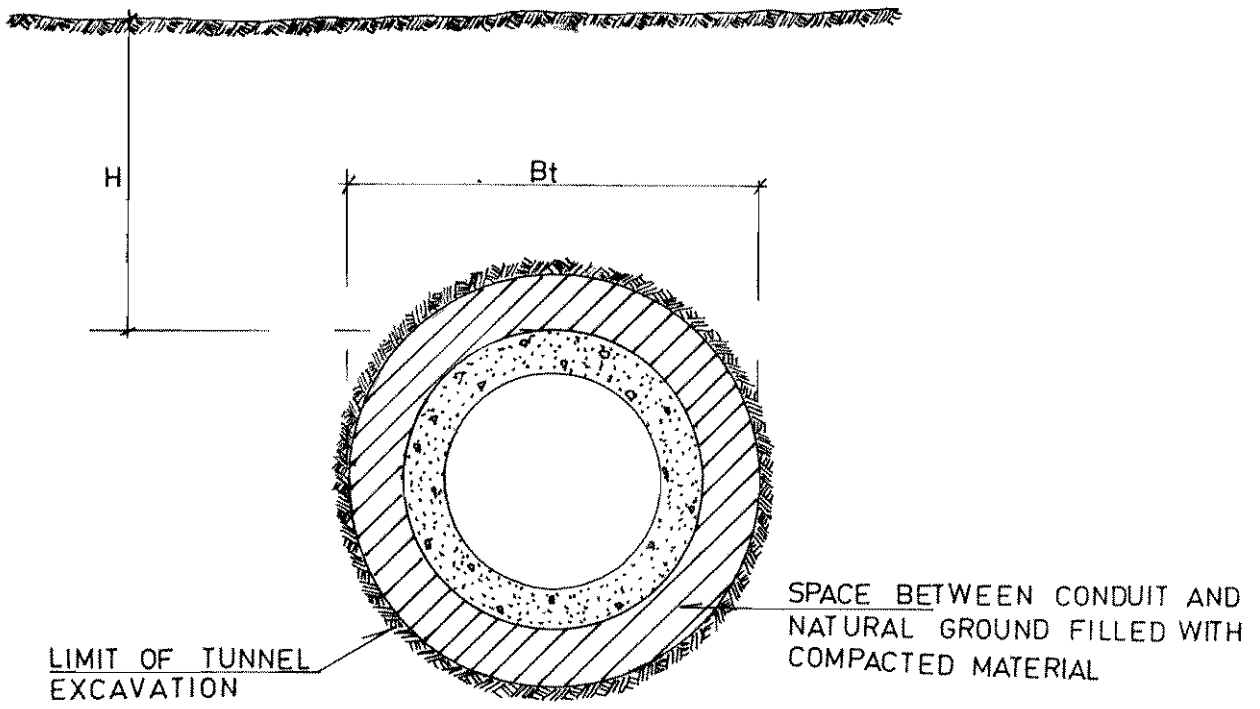

FIG. 6.10 : CONDUIT IN TUNNEL

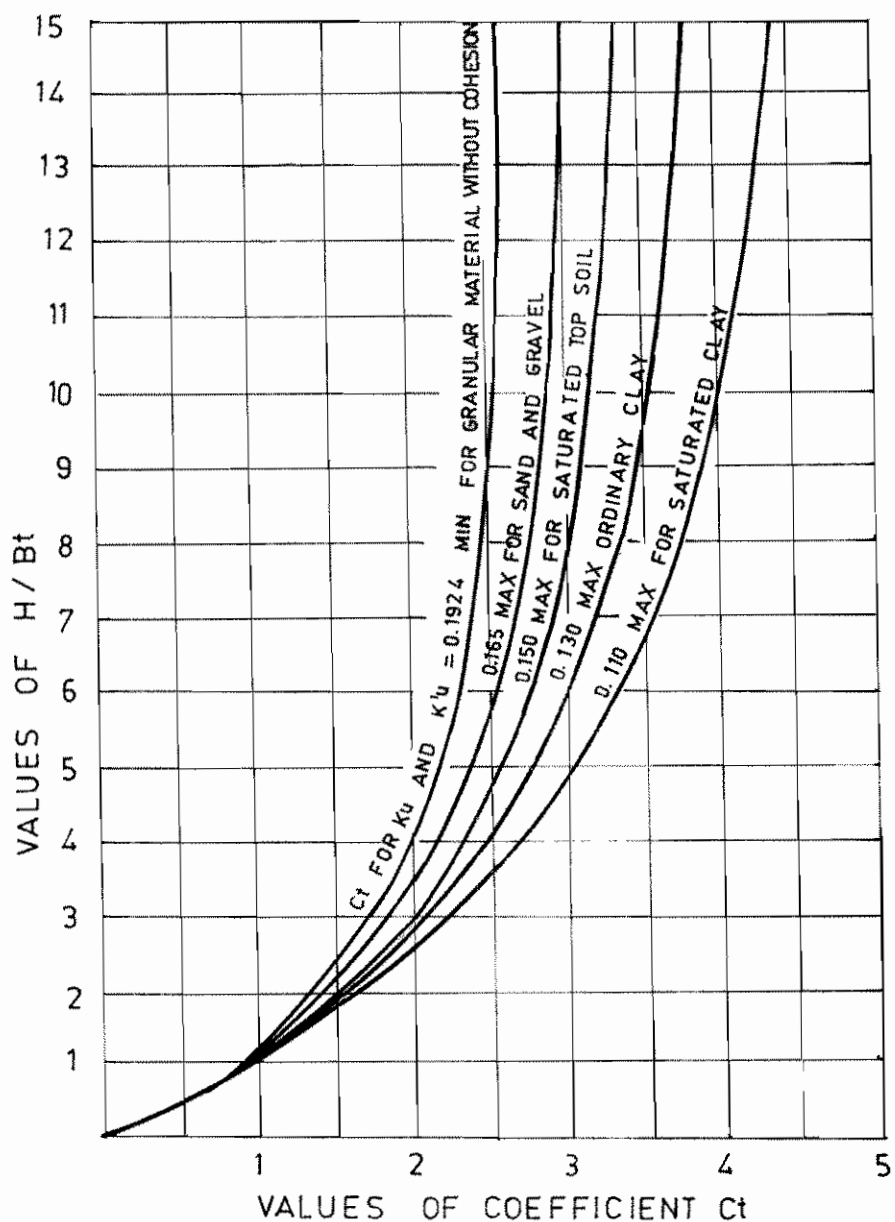

FIG. 6.11: DIAGRAM FOR COEFFICIENT C_t FOR TUNNELS IN UNDISTURBED SOIL.

Recommended values of coefficient of cohesion for different types of soils are given in Table 6.4

TABLE 6.4
COHESION COEFFICIENTS FOR DIFFERENT SOILS

Type of Soil	Kg/m ²
Soft Clay	200
Medium Clay	1200
Hard Clay	4700
Loose Dry Sand	0
Silty Sand	500
Dense Sand	1400
Saturated top soil	500

6.3.2.4 EFFECT OF SUBMERGENCE

Sewers may be laid in trenches or under embankment in areas which may be temporarily or permanently submerged in water. The fill load in such cases will be reduced and will correspond to the buoyant weight of the fill material. However, effect of submergence could be ignored which provides an additional factor of safety, but it may be necessary to check whether a pipe is subject to flotation. Under submergence, the minimum height of the fill material that will be required to prevent flotation ignoring the frictional forces in the fill can be determined from the equation.

$$H_{min} B_c (w_s - w_w) + W_c = (\pi/4) B_c^2 w_w \quad (6.9)$$

Where

H_{min} = minimum height of fill material in m

w_s = the saturated density of the soil in kg/m³

w_w = the density of water in kg/m³

W_c = the unit weight of the empty pipe in kg/linear meter and

B_c = the outside width of the conduit in m.

Wherever sufficient height of fill material is not available, anti-flotation blocks should be provided. (As shown in Example IX in Appendix 6.2).

6.4 LOAD ON CONDUIT DUE TO SUPERIMPOSED LOADS

The types of superimposed loads which are generally encountered in buried conduits may be categorised as (a) concentrated load and (b) distributed load. These are explained diagrammatically in Fig.6.12.

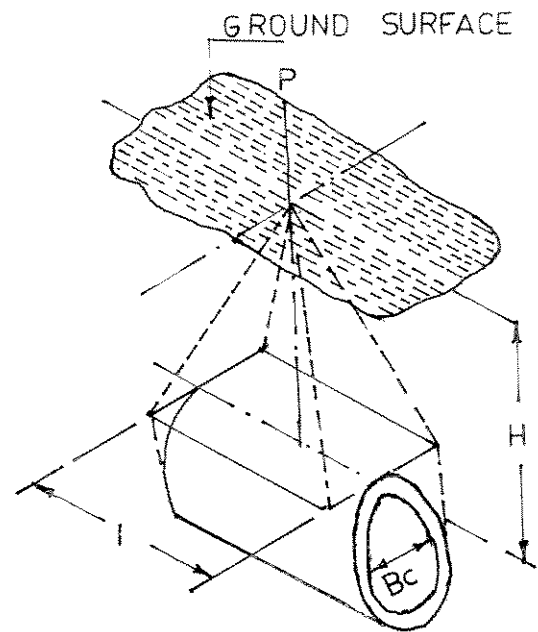

FIG6.I2A: CONCENTRATED SUPERIMPOSED
LOAD VERTICALLY CENTRED OVER CONDUIT.

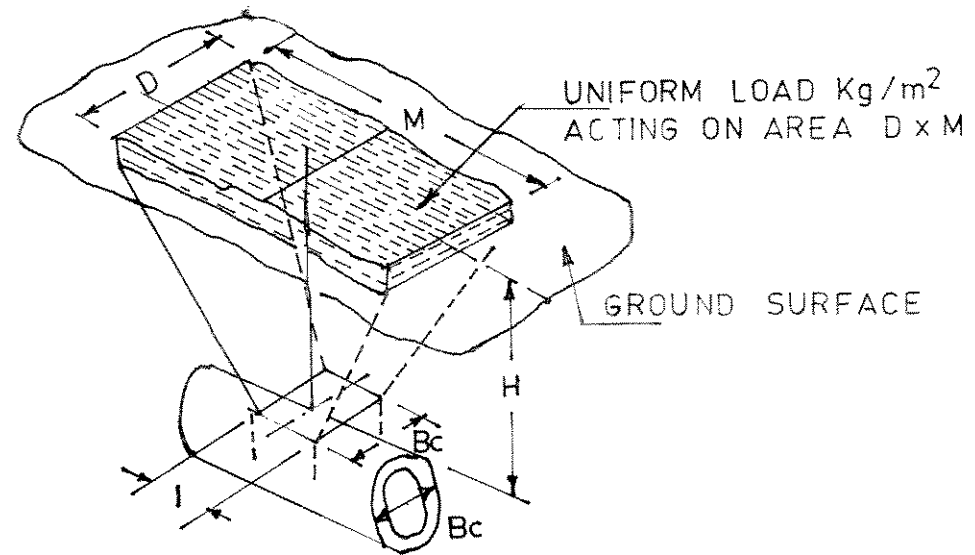

FIG6.I2B: DISTRIBUTED SUPERIMPOSED LOAD
VERTICALLY CENTRED OVER CONDUIT.

6.4.1 Concentrated Load

The formula for load due to superimposed concentrated load such as a truck wheel (Fig.6.12) is given in the following form by Holl's integration of Boussinesq's formula

$$W_{sc} = C_s (PF/L) \quad (6.10)$$

Where

W_{sc} = the load on the conduit in kg/m

P = the concentrated load in kg acting on the surface

F = the impact factor (1.0 for air field runways, 1.5 for highway traffic and air field taxi ways, 1.75 for railway traffic) and

C_s = the load coefficient which is a function of

$$\frac{B_c}{2H} \quad \text{and} \quad \frac{L}{2H}$$

Where

H = the height of the top of the conduit to ground surface in m

B_c = the outside width of conduit in m, and

L = the effective length of the conduit to which the load is transmitted in m.

Values of c_s for various values of $(B_c / 2H)$ and $(L / 2H)$ are obtained from Table 6.5

The effective length of the conduit is defined as the length over which the average load due to surface traffic units produces the same stress in the conduit wall as does the actual load which varies in intensity from point to point. This is generally taken as 1m or the actual length of the conduit if it is less than 1m.

6.4.2 Distributed Load

For the case of distributed superimposed loads, the formula for load on conduit is given by

$$W_{sd} = C_s p F B_c \quad (6.11)$$

Where

W_{sd} = the load on the conduit in kg/m

p = the intensity of the distributed load in kg/m²

F = the impact factor

B_c = The width of the conduit in m

C_s = The load coefficient, a function of $D/2H$ and $L/2H$ from Table 6.5

H = The height of the top of conduit to the ground surface in m and

D and L are width and length in m respectively of the area over which the distributed load acts.

TABLE - 6.5

VALUES OF LOAD COEFFICIENTS, C_s FOR CONCENTRATED AND DISTRIBUTED SUPERIMPOSED LOADS VERTICALLY CENTRED OVER CONDUITS

D 2H or Bc 2H	M -----or----- 2H 2H		0.3	0.4	0.5	0.6	0.7	0.8	0.9	1.0	1.2	1.5	2.0	5.0
	0.1	0.2												
0.1	0.019	0.037	0.053	0.067	0.079	0.089	0.097	0.103	0.108	0.112	0.117	0.121	0.124	0.128
0.2	0.037	0.072	0.103	0.131	0.155	0.174	0.189	0.202	0.211	0.219	0.229	0.238	0.244	0.248
0.3	0.053	0.103	0.149	0.190	0.224	0.252	0.274	0.292	0.306	0.318	0.333	0.345	0.355	0.360
0.4	0.067	0.131	0.190	0.241	0.284	0.320	0.349	0.373	0.391	0.405	0.425	0.440	0.454	0.460
0.5	0.079	0.155	0.224	0.284	0.336	0.379	0.414	0.441	0.463	0.481	0.505	0.525	0.540	0.548
0.6	0.089	0.174	0.252	0.320	0.379	0.428	0.467	0.499	0.524	0.544	0.572	0.596	0.613	0.624
0.7	0.097	0.189	0.274	0.349	0.414	0.467	0.511	0.546	0.584	0.597	0.628	0.650	0.674	0.688
0.8	0.103	0.202	0.292	0.373	0.441	0.499	0.546	0.584	0.615	0.639	0.674	0.703	0.725	0.740
0.9	0.108	0.211	0.306	0.391	0.463	0.524	0.574	0.615	0.647	0.673	0.711	0.742	0.766	0.784
1.0	0.112	0.219	0.318	0.405	0.481	0.544	0.597	0.639	0.673	0.701	0.740	0.774	0.800	0.816
1.2	0.117	0.229	0.333	0.425	0.505	0.572	0.628	0.674	0.711	0.740	0.783	0.820	0.849	0.868
1.5	0.121	0.238	0.345	0.440	0.525	0.596	0.650	0.703	0.742	0.774	0.820	0.861	0.894	0.916
2.0	0.124	0.244	0.355	0.454	0.540	0.613	0.674	0.725	0.766	0.800	0.849	0.894	0.930	0.956

For class AA IRC loading, in the critical case of wheel load of 6.25 tonnes, the intensity of distributed load with wheel area 300mm x 150mm is given by

$$P = \frac{6.25}{0.3 \times 0.15} \text{ in T/m}^2$$

6.4.3 Conduits Under Railway Track

The load on conduits under railway track is given by

$$W = 4C_s UB_c \quad (6.12)$$

Where

U is the uniformly distributed load in tonnes/m² from the surface directly over the conduit and equal to

$$U = \frac{PF+2W_t B}{4AB} = \frac{PF}{4AB} + \frac{W_t}{2A} \quad (6.13)$$

Where

P = axle load in tonnes (22.5 tonnes for Broad gauge)

F = impact factor for railroad = 1.75

2A = length of the sleeper in m (2.7m for Broad gauge)

2B = distance between the two axles (1.84m for broad gauge)

W_t = weight of the track structure in tonnes/m (0.3 tonnes/m for broad gauge)

C_s = load coefficient which depends on the height of the top of sleeper from the top of the conduit and

B_c = width of the conduit in m.

For broad gauge track the formula will reduce to:

$$W = 32.14 C_s B_c \quad (6.14)$$

6.5 SUPPORTING STRENGTH OF RIGID CONDUIT

The ability of a conduit to resist safely the calculated earth load depends not only on its inherent strength but also on the distribution of the vertical load and bedding reaction and on the lateral pressure acting against the sides of the conduit. The inherent strength of a rigid conduit is usually expressed in terms of the three edge bearing test results, the conditions of which are, however, different from the field load conditions. The magnitude of the supporting strength of a pipe as installed in the field is dependent upon the distribution of the vertical load and the reaction against the bottom of the pipe. It also depends on the magnitude and distribution of the lateral pressure acting on the sides of the pipe.

6.5.1 Laboratory Test Strength

All rigid pipes may be tested for strength in the Laboratory by the three edge bearing test (ultimate load). Methods of test and minimum strength for concrete (unreinforced and reinforced) stoneware and AC pipes and other details are given in Appendix 6.1

6.5.2 Field Supporting Strength

The field supporting strength of a rigid conduit is the maximum load per unit length which the pipe will support while retaining complete serviceability when installed under specified conditions of bedding and backfilling. The field supporting strength, however does not include any factor of safety. The ratio of the strength of a pipe under any stated condition of loading and bedding to its strength measured by the three edge bearing test is called the load factor.

The load factor does not contain a factor of safety. Load factors have been determined experimentally and analytically for the commonly used construction condition for both trench and embankment conduits.

6.5.3 Supporting Strength in Trench Conditions

6.5.3.1 CLASSES OF BEDDING

Four classes, A,B,C and D of bedding used most often for pipes in trenches are illustrated in figure 6.13. Class A bedding may be either concrete cradle or concrete arch. Class B is a bedding having a shaped bottom or compacted granular bedding with a carefully compacted backfill. Class C is an ordinary bedding having a shaped bottom or compacted granular bedding but with a lightly compacted backfill. Class D is one with flat bottom trench with no care being taken to secure compaction of backfill at the sides and immediately over the pipe and hence is not recommended. Class B or C bedding with a compacted granular bedding is generally recommended. Shaped bottom is impracticable and costly and hence is not recommended. The pipe bedding materials must remain firm and not permit displacement of pipes.

The material has to be uniformly graded or wellgraded. Uniformly graded materials include pea gravel or one size materials with a low percentage of over and undersized particles. Well graded materials containing several sizes of particles in stated proportions, ranging from a maximum to a minimum size, coarse sand, pea gravel, crushed gravel, crushed screenings, can be used for pipe bedding. Fine materials or screenings are not satisfactory for stabilising trench bottoms and are difficult to compact in a uniform manner to provide proper pipe bedding.

Well graded material is most effective for stabilizing trench bottom and has a lesser tendency to flow than uniformly graded materials. However, uniformly graded material is easier to place and compact above sewer pipes.

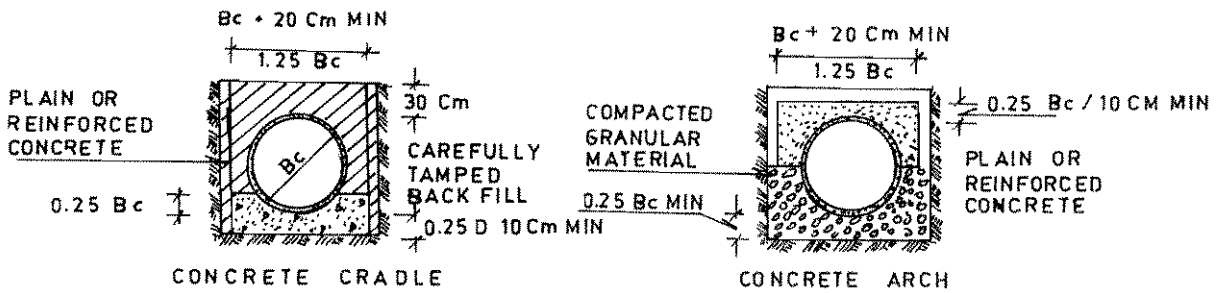

CLASS_A

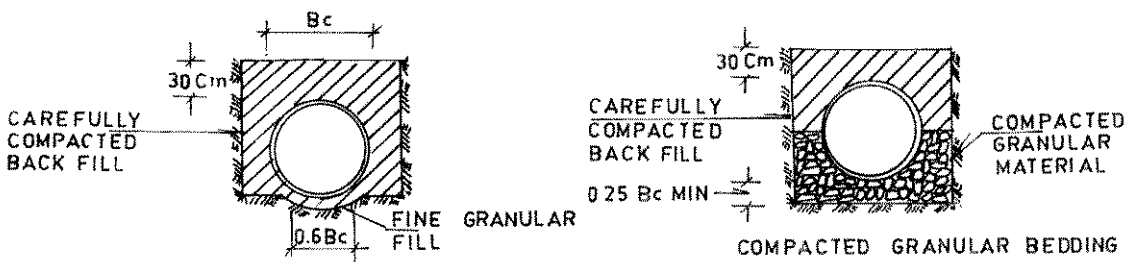

SHAPED BOTTOM WITH TAMPED BACK FILL
(NOT RECOMMENDED)

CLASS_B

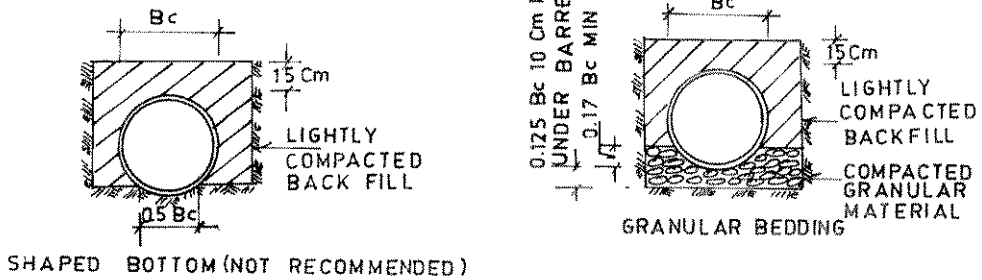

SHAPED BOTTOM (NOT RECOMMENDED)

CLASS_C

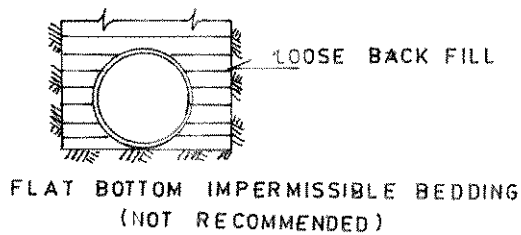

CLASS_D

FIG.6.13: CLASSES OF BEDDING FOR CONDUIT IN TRENCH

NOTE: IN ROCK, TRENCH IS EXCAVATED ATLEAST 15 cm BELOW THE BELL OF THE PIPE EXCEPT WHERE CONCRETE CRADLE IS USED.

6.5.3.2 LOAD FACTORS

The load factors for the different classes of Bedding are given in Table 6.6.

TABLE 6.6
LOAD FACTORS FOR DIFFERENT CLASSES OF BEDDING

Class of Bedding	Condition	Load Factor
A a	Concrete cradle-plain concrete and lightly tamped backfill	2.2
A b	Concrete cradle-plain concrete with carefully tamped backfill	2.8
A c	Concrete cradle - RCC with P-0.4%	upto 3.4
A d	Arch type-plain concrete	2.8
	RCC with P-0.4%	upto 3.4
	RCC with P-1.0%	upto 4.8
	('P' is the ratio of the area of steel to the area of concrete at the crown)	
B	Shaped bottom or compacted granular bedding with carefully compacted backfill	1.9
C	Shaped bottom or compacted granular bedding with lightly compacted backfill	1.5
D	Flat bottom trench	1.1

The granular material used must stabilize the trench bottom in addition to providing a firm and uniform support for the pipe. Well graded crushed rock or gravel with the maximum size not exceeding 25mm is recommended for the purpose.

Where rock or other unyielding foundation material is encountered, bedding may be according to one of the Classes A,B or C but with the following additional requirements.

Class A: The hard unyielding material should be excavated down to the bottom of the concrete cradle.

Class B or C: The hard unyielding material should be excavated below the bottom of the pipe and pipe bell to a depth of atleast 15cm.

The width of the excavation should be atleast 1.25 times the outside dia of the pipe and it should be refilled with granular material.

Total encasement of non-reinforced rigid pipe in concrete may be necessary where the required safe supporting strength cannot be obtained by other bedding methods. The load factor for concrete encasement varies with the thickness of concrete. The effect of M-200 concrete encasement of various thicknesses on supporting strength of pipe under trench conditions is given in Fig. 6.14.

6.5.4 Supporting Strength in Embankment Conditions

The soil pressure against the sides of a pipe placed in an embankment may be significant in resisting the vertical load on the structure.

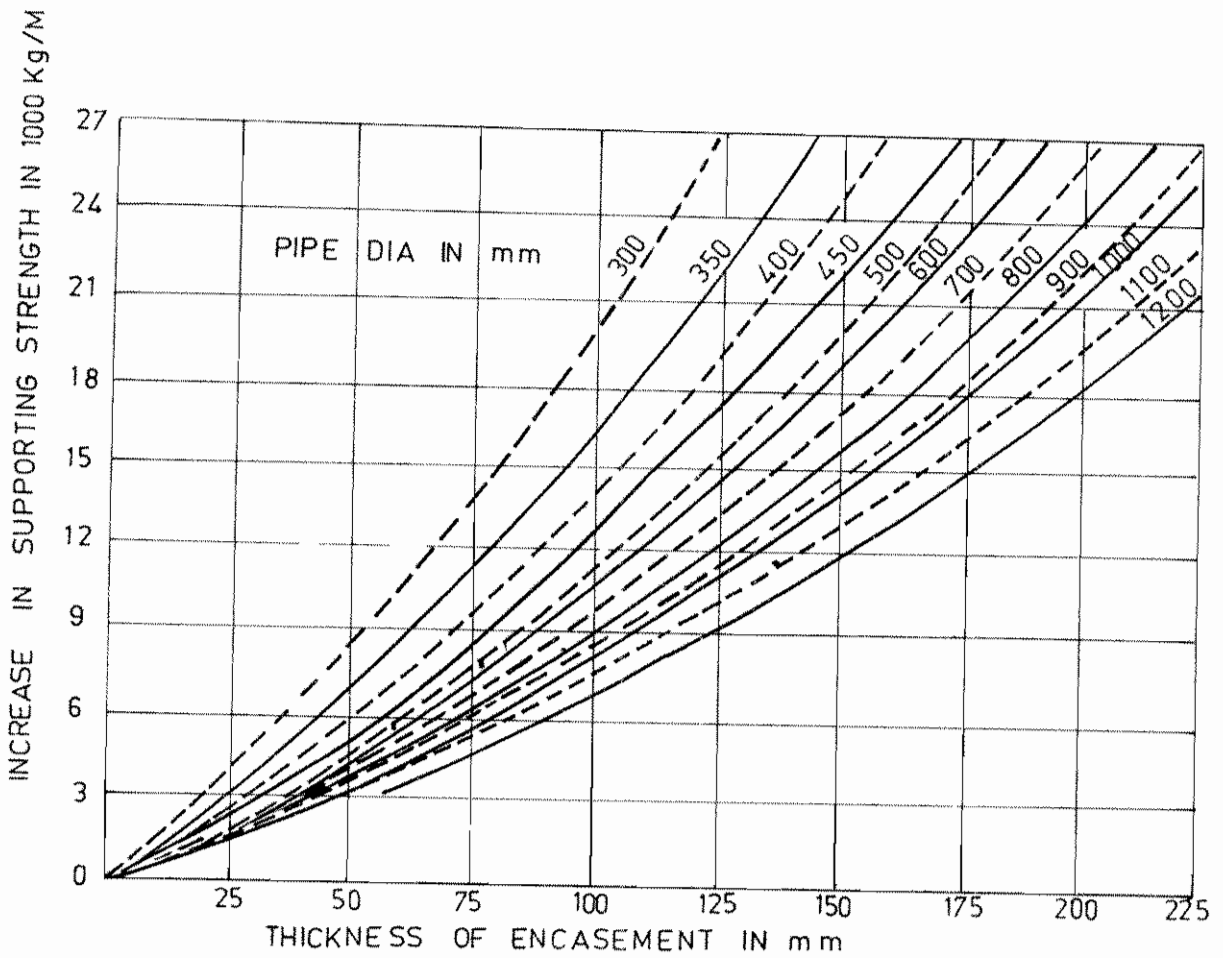

FIG.6.14: EFFECT OF M-200 CONCRETE ENCASEMENT OF VARIOUS THICKNESS ON SUPPORTING STRENGTH OF PIPE UNDER TRENCH CONDITIONS.

6.5.4.1 CLASSES OF BEDDING

The beddings which are generally adopted for projecting conduits laid under the embankment conditions of installation are illustrated in Figure 6.15. The classification of the beddings are as under:

- CLASS A:** In this case the conduit is laid on a mat of concrete.
- CLASS B:** The conduit is laid on accurately shaped earth to fit the bottom of the pipe and the sides are filled with thoroughly tamped earth.
- CLASS C:** In this type of bedding the conduit is laid on accurately shaped earth to fit the bottom surface of the conduit. For rock foundations the conduit is laid on a layer of granular cushion and the sides of the conduit are filled up.
- CLASS D:** The conduit is laid on earth not shaped to fit the bottom of the conduit. In case of rocky soil the conduit is laid on a shallow granular cushion.

6.5.4.2 LOAD FACTORS

The load factor for rigid pipes installed as projecting conduits under embankments or in wide trenches is dependent on the type of bedding, the magnitude of the active lateral soil pressure and on the area of the pipe over which the active lateral pressure acts.

The load factor for projecting circular conduits may be calculated by the formula

$$L_r = \frac{1.431}{Nzq} \quad (6.15)$$

Where

L_r = the load factor

N = a parameter dependent on the type of bedding

z = a parameter dependent upon the area over which the lateral pressure acts effectively and

q = the ratio of total lateral pressure to total vertical load on pipe.

a) Positive Projecting Conduits

The ratio 'q' for positive projecting conduits may be estimated by the formula

$$q = (mk / C_c) [(H/B_c) + (m/2)] \quad (6.16)$$

Where

k = the Rankine's ratio which may be taken as 0.33. The value of N for different types of beddings for circular pipes are given in Table 6.7.

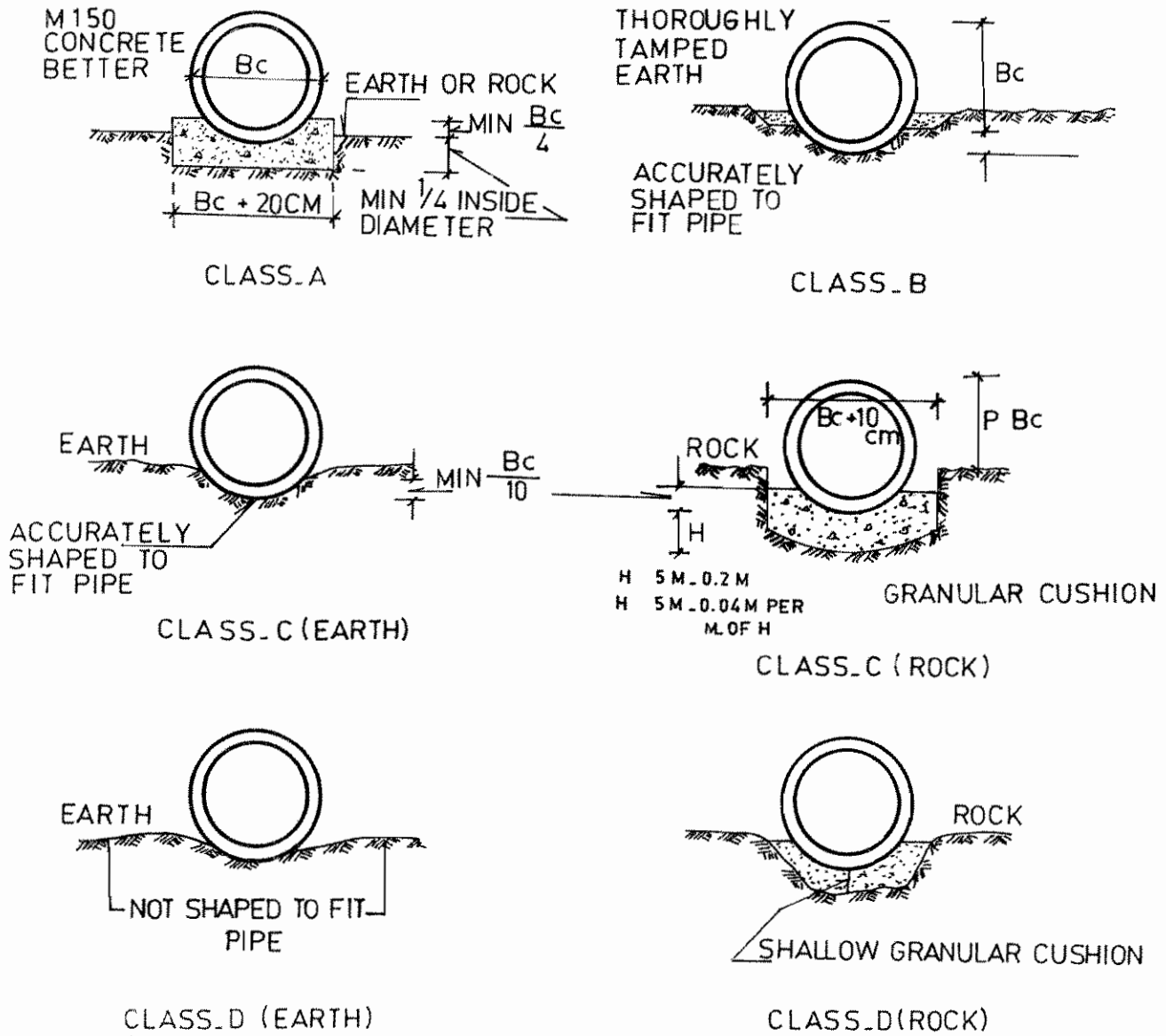

FIG. 6.15: CLASSES OF BEDDING FOR PROJECTING CONDUITS

TABLE 6.7
VALUES OF 'N' FOR DIFFERENT PIPE BEDDINGS

Type of Bedding	Value of 'N'
'A' - Reinforced concrete cradle	0.42 to 0.51
'A' - Plain concrete cradle	0.51 to 0.64
'B'	0.71
'C'	0.84
'D'	1.31

The value of 'z' in case of circular pipes is given in Table 6.8.

TABLE 6.8
VALUES OF 'Z' FOR DIFFERENT PIPE BEDDINGS

Fraction of conduit on which lateral pressure acts 'm'	Value of 'z' for	
	'A' Class Beddings	Other Beddings
0.0	0.150	0.000
0.3	0.743	0.217
0.5	0.856	0.423
0.7	0.811	0.594
0.9	0.678	0.655
1.0	0.638	0.638

b) Negative Projecting Conduits

The load factor for negative projecting conduits may also be determined by the equations (6.15) and (6.16) with a value of k of 0.15, provided the side fills are well compacted.

c) Imperfect Trench Conditions

The equations for positive projecting conditions will hold good for those conditions as well.

6.5.5 Conduits Under Simultaneous Internal Pressure and External Loading

Simultaneous action of internal pressure and external load gives a lower supporting strength of a pipe than what it would be if the external load acted alone.

If the bursting strength and the three edge strength of a pipe are known, the relation between the internal pressure and external loads which will cause failure may be computed by means of the formula

$$t = \frac{T(1 - s^2)}{S} \quad (6.17)$$

Where

- t = internal pressure in kg/cm² at failure when external load is simultaneously acting
- T = bursting strength of a pipe in kg/cm² when no external load is simultaneously acting
- s = three-edge bearing Load at failure in kg/linear metre when there is simultaneous action of internal pressure and
- S = Three edge bearing load at failure in kg/linear metre when there is no internal pressure simultaneously acting.

6.6 RELATIONSHIP BETWEEN THE DIFFERENT ELEMENTS IN STRUCTURAL DESIGN

The basic design relationships between the different design elements are as follows for rigid pipes

$$\text{Safe working strength} = \frac{\text{Ultimate three edge bearing strength}}{\text{Factor of safety}}$$

$$\text{Safe field supporting strength} = \text{Safe working strength} \times \text{Load factor}$$

Appendix 6.1 gives the details of three edge bearing Tests.

6.7 RECOMMENDATIONS

The factor of safety recommended for concrete pipes for sewers is '1.5' which is considerably less as compared to that for most engineering structures which have a factor of safety of atleast 2.5. As the margin of safety against the ultimate failure is low, it becomes imperative to guarantee that the loads imposed on sewer pipes are not greater than the design loads for the given installation conditions. In order to achieve this objective the following procedures are recommended.

1. Width of the trench specified for a particular job should be minimum in consonance with the requirements of adequate working space to allow access to all parts and joints of pipes.
2. Specification should lay proper emphasis on the limit of the width of trench to be adopted in the field which should not exceed that adopted in the design calculations. Any deviations from this requirement during the construction should be investigated for their possible effect on the load coming on the pipe and steps should be taken to improve the safe supporting strength of pipe for this condition of loading by adopting suitable bedding or such other methods when necessary.
3. The Field Engineer should keep in touch with the Design Engineer through out the duration of the Project and any deviation from the design assumptions due to the exigencies of work, should be immediately investigated and corrective measures taken in time.

4. All pipes used on the work should be tested as per the IS specifications and test certificates of the manufacturers should be furnished for every consignment brought to the site.
5. Whenever shoring is used, the pulling out of planks on completion of work, should be carried out in stages and this should be properly supervised to ensure that the space occupied by the planks is properly backfilled.
6. Proper backfilling methods both as regards to selection of materials, methods of placing and proper compaction should be in general agreement with the design assumptions.

6.8 ILLUSTRATIVE EXAMPLES

Illustrative examples for structural design of Buried Conduits are given in Appendix 6.2.

CONSTRUCTION OF SEWERS

CHAPTER 7

CONSTRUCTION OF SEWERS**7.1 CONSTRUCTION METHODS**

The design and the construction of sewers are so interdependent, the knowledge of one is an essential pre-requisite to the competent performance of the other. The ingenuity of the designer and supervising engineer is continually called for, to reduce the construction cost and to achieve a quality workmanship. Barring unforeseen conditions it shall be the responsibility of the supervising engineer and the contractor to complete the work as shown on the plans at minimum cost and with minimum disturbance of adjacent facilities and structures.

7.1.1 Trench**7.1.1.1 DIMENSIONS**

The width of trench at and below the top of a sewer should be the minimum necessary for its proper installation with the due consideration to its bedding. The width of a sewer trench depends on the type of shoring (single stage or two stage), working space required in the lower part of the trench and the type of ground below the surface. The width of the trench at different levels from the top of the sewer to the ground surface is primarily related to its effect upon the adjoining services and nearby structures. In undeveloped areas or open country, excavation with side slope shall be permissible from the top of the sewer to the ground surface instead of vertical excavation with proper shoring. In developed areas, however, it is essential to restrict the trench width so as to protect the existing facilities and properties and to reduce the cost of restoring the surface. Increase in width over the minimum required would unduly increase the load on the pipe.

7.1.1.2 EXCAVATION

Excavation for sewer trenches for laying sewers shall be in straight lines and to the correct depths and gradients required for the pipes as specified in the drawings. The material excavated from the trench shall not be deposited very close to the trench to prevent the weight of the materials from causing the sides of the trench to slip or fall. The sides of the trench shall, however, be supported by shoring where necessary to ensure proper and speedy excavation. In case, the width of the road or lane where the work of excavation is to be carried out is so narrow as to warrant the stacking of materials near the trench, the same shall be taken away to a place to be decided by the Engineer-in-Charge. This excavated material shall be brought back to the site of work for filling the trench.

In case the presence of water is likely to create unstable soil conditions, a wellpoint system shall be employed to drain the immediate area of the sewer trench prior to excavation operation. A well point system consists of a series of perforated pipes driven or jetted into the water bearing strata on either side of a sewer trench and connected with a header pipe leading to a pump.

In the event of excavation being made deeper than necessary, the same shall be filled and stabilised.

7.1.1.3 SHORING

The shoring shall be adequate to prevent caving in of the trench walls or subsidence of areas adjacent to the trench. In narrow trenches of limited depth, a simple form of shoring shall consist of a pair of 40 to 50mm thick and 30cm wide planks set vertically at intervals and firmly strutted. For wider and deeper trenches a system of wall plates (wales) and struts of heavy timber section is commonly used. Continuous sheeting shall be provided outside the wall plates to maintain the stability

of the trench walls. The number and the size of the wall plates shall be fixed considering the depth of trench and type of soil. The cross struts shall be fixed in a manner to maintain pressure against the wall plates which in turn shall be kept pressed against the timber sheeting by means of timber wedges or dog spikes.

In non-cohesive soils combined with considerable ground water, it may be necessary to use continuous interlocking steel sheet piling to prevent excessive soil movements due to ground water percolation. Such sheet piling shall extend at least 1.5m below the bottom of the trench unless the lower part of the trench is in fine material. In case of deep trenches, if conditions demand, excavation and shoring may be done in stages.

7.1.1.4 UNDERGROUND SERVICES

All pipes, ducts, cables, mains and other services exposed due to the excavation shall be effectively supported.

7.1.1.5 DEWATERING

Trenches for sewer construction shall be dewatered for the placement of concrete and laying of pipe sewer or construction of concrete or brick sewer and kept dewatered until the concrete foundations, pipe joints or brick work or concrete have cured. The pumped out water from the trenches shall be disposed off in existing storm water drainage arrangement nearby. In the absence of any such arrangement the pumped water may be drained through completed portion of sewer to a permanent place of disposal. Where a trench is to be retained dry for a sufficient period of time to facilitate the placement of forms for sewer construction an underdrain shall be laid of granular material leading to a sump for further disposal. Precautions are to be taken to arrest floating of sewers laid, arising out of induced buoyancy during rainy season. Reference may be made to 6.3.2.4 for more details in this regard.

7.1.1.6 FOUNDATION AND BEDDING

Where a sewer has to be laid in a soft under ground strata or in a reclaimed land, the trench shall be excavated deeper than what is ordinarily required. The trench bottom shall be stabilised by the addition of coarse gravel or rock, in case of very bad soil the trench bottom shall be filled in with cement concrete of appropriate grade.

In the areas subject to subsidence, the pipe sewer should be laid on suitable supports or concrete cradle supported on piles.

In the case of cast-in-situ sewers, an R.C.C. section with both transverse and longitudinal steel reinforcement shall be provided when intermittent variations in soil bearing capacity are encountered. In case of long stretches of very soft trench bottom, soil stabilization shall be done either by rubble, concrete or wooden crib. For details regarding bedding types and materials reference may be made to 6.5.3.

7.1.2 Tunnelling

Tunnels are employed in sewer systems when it becomes economical, considering the nature of soil to be excavated and surface conditions with reference to the depth at which the sewer is to be laid. Generally in soft soils the minimum depth is about 10m. In rocks, however, tunnels may be adopted at lesser depths. In busy and high activity zones crowded condition of the surface, expensive pavements or presence of other service facilities near the surface sometimes make it advantageous to tunnel at shallower depths. Each situation has to be analysed in detail before any decision to tunnel is taken.

7.1.2.1 SHAFTS

Shafts are essential in tunnelling to gain access to the depth at which tunnelling is to be done to remove the excavated material. The size of shaft depends on the type and size of machinery employed for tunnelling irrespective of the size of the sewer.

7.1.2.2 METHODS OF TUNNELLING

The tunnelling methods adopted for sewer construction can be classified generally as auger or boring, jacking and mining.

a) *Auger or Boring*

In this method, rigid steel or concrete pipes are pushed into ground to reasonable distances and the earth removed by mechanical means from the shaft or pit location. Presence of boulders is a serious deterrent for adoption of this method, in which case it may be more economical to first install an oversize lining by conventional tunnelling or jacking and fill the space between the pipe and lining with sand, cement or concrete.

b) *Jacking*

In this procedure, the leading pipe is provided with a cutter or edge to protect the pipe while jacking. Soil is gradually excavated and removed through the pipe as successive lengths of pipes are added between the leading pipe and the jacks and pushed forward taking care to limit the jacking upto the point of excavation. This method usually results in minimum disturbance of the natural soils adjacent to the pipe. Jacking operation should continue without interruption as otherwise soil friction may increase, making the operation more difficult.

Jacking of permanent tunnel lining is generally adopted for sewers of sizes varying from 750 to 2750 mm, depending upon the conditions of soil and the location of the line. The pipes selected should be able to withstand the loads exerted by the jacking procedure. The most common pipes used for this are reinforced concrete or steel.

c) *Mining*

Tunnels larger than 1.5 m are normally built with the use of tunnel shields, boring machines or by open face mining depending on the type of material met with. Rock tunnels normally are excavated open-face with conventional mining methods or with boring tools.

Tunnel shields are used as a safety precaution in mining operations in very soft clay or in running sand especially in built up areas. In this method, a primary lining of adequate strength to support the surrounding earth is installed to provide progressive backstop for the jacks which advance the shield. As the excavation continues the lining may be installed either against the earth, filling the annular space by grouting with pea gravel or the lining may be expanded against the earth as the shield advances; the latter eliminating need for any grouting.

Boring machines of different types have been developed for tunnel excavation in clay and rock. They are usually provided with cutters mounted on a rotating head which is moved forward as boring operations continue. Earth excavated is usually carried by a conveyor system. Some machines are also equipped with shields. Though the machines are useful in fairly long runs through similar material, difficulties are encountered when the material to be excavated varies.

Open face mining without shields are adopted in particular instances where the conditions permit such operation as in rock. Segmental support of timber or steel is used for the sides and the top of the tunnel.

7.1.3 Laying of Pipe Sewers

In laying sewers, the centre of each manhole shall be marked by a peg. Two wooden posts 100mm x 100mm x 1800mm high shall be fixed on either side at nearly equal distance from the peg and sufficiently clear of all intended excavation. The sight rail when fixed on these posts shall cross the centre of manhole. The sight rails made from 250 mm wide x 40 mm thick wooden planks and screwed with the top edge against the level marks shall be fixed at distances more than 30m apart along the sewer alignment. The centre line of the sewer shall be marked on the sight rail. These vertical posts and the sight rails shall be perfectly square and planed smooth on all sides and edges. The sight rails shall be painted half white and half black alternately on both the sides and the tee heads and cross pieces of the boning rods shall be painted black. When the sewers converging to a manhole come in at various levels there shall be a rail fixed for every different level.

The boning rods with cross section 75mm x 50mm of various lengths shall be prepared from wood. Each length shall be a certain number of metres and shall have a fixed tee head and fixed intermediate cross pieces, each about 300mm long. The top edge of the cross pieces shall be fixed at a distance below the top edge equal to, the outside dia. of the pipe, the thickness of the concrete bedding or the bottom of excavation, as the case may be. The boning staff shall be marked on both sides to indicate its full length.

The posts and the sight rails shall in no case be removed until the trench is excavated, the pipes are laid, jointed and the filling is started.

When large sewer lines are to be laid or where sloped trench walls result in top-of-trench widths too great for practical use of sight rails or where soils are unstable, stakes set in the trench bottom itself on the sewer line, as rough grade for the sewer is completed, would serve the purpose.

7.1.3.1 STONEWARE PIPES

The stoneware pipes shall be laid with sockets facing up the gradient, on desired bedding. Special bedding, hunching or encasing may be provided where conditions so demand (as discussed in 6.5). All the pipes shall be laid perfectly true, both to line and gradient. (IS:4127-1983). At the close of each day's work or at such other times when pipe is not being laid, the end of the pipe should be protected by a close fitting stopper.

7.1.3.2 R.C.C. PIPES

The R.C.C. pipes shall be laid in position over proper bedding, the type of which may be determined in advance, the abutting faces of the pipes being coated by means of a brush with bitumen in liquid condition. The wedge shaped groove in the end of the pipe shall be filled with sufficient quantity of either special bituminous compound or sufficient quantity of cement mortar of 1:3. The collar shall then be slipped over the end of the pipe and the next pipe butted well against the plastic ring by appliances so as to compress roughly the plastic ring or cement mortar into the grooves, care being taken to see that concentricity of the pipes and the levels are not disturbed during the operation. Spigot and socket R.C.C. pipes shall be laid in manner similar to stoneware spigot and socket pipes. The structural requirements as discussed in Chapter 6 and IS:783-1967 may be followed.

7.1.3.3 CAST-IN-SITU CONCRETE SECTIONS

For sewer sizes beyond 2m internal dia cast-in-situ concrete sections shall generally be used, the choice depending upon the relative costs worked out for the specific project. The concrete shall be cast in suitable number of lifts usually two or three. The lifts are generally designated as the invert, the side wall and the arch.

7.1.3.4 CONSTRUCTION OF BRICK SEWERS

Sewers larger than 2m are generally constructed in brick work. The brick work shall be in cement mortar of 1:3 and plastered smooth with cement plaster of 1:2, 20mm thick both from inside and outside. A change in the alignment of brick sewer shall be on a suitable curve conforming to the surface alignment of road. Construction shall conform to IS:2212-1962 in general.

7.1.3.5 CAST IRON PIPES

The pipes shall be laid in position with the socket ends of all pipes facing up gradient. Any deviations either in plan or in elevation of less than 11¼ degree shall be effected by laying the straight pipes round the flat curve of such radius that the minimum thickness of lead in a lead joint at the face of the socket, shall not be reduced below 6mm. The spigot shall be carefully pushed into the socket with one or more laps of spun yarn wound round it. Each joint shall be tested before running the lead, by passing completely round it, a wooden gauge notched out to the correct depth of lead and the notch being held close up against the face of socket. IS: 3114-1985 should be followed in setting out the sewers.

7.1.4 Jointing of Sewers

Joints of pipe sewers may generally be any of the following types:

- i) Spigot and socket joint (rigid and semi flexible)
- ii) Collar Joint (rigid and semi flexible)
- iii) Cast Iron detachable joint (semi flexible)
- iv) Coupling joint (semi flexible)

Cement joints are rigid and even a slight settlement of pipes can cause cracks and hence leakage. To avoid this problem it is recommended that semi flexible joints should be used.

7.1.4.1 STONEWARE PIPES

All the pipe joints shall be caulked with tarred gasket in one length for each joint and sufficiently long to entirely surround the spigot end of the pipe. The gasket shall be caulked lightly home but not so as to occupy more than a quarter of the socket depth. The socket shall then be filled with a mixture of one part of cement and one part of clean fine sand mixed with just sufficient quantity of water to have a consistency of semi-dry condition and a fillet shall be formed round the joint with a trowel forming an angle of 45 degrees with the barrel of the pipe (IS:4127 - 1983). Rubber gaskets may also be used for jointing.

7.1.4.2 CONCRETE PIPES

Concrete spigot and socket pipes are laid and jointed as described above for glazed stoneware spigot and socket pipes with yarn or rubber gasket and cement.

Asbestos cement pipes are jointed by coupling joints or C.I. detachable joints.

Large size concrete sewers have 'ogee' joints in which the pipe has mortise at one end and a tenon to suit at the other end and are jointed with cement or asphalt. A concrete collar sufficiently wide to cover and overlap the joint is fixed on it.

The collars shall be placed symmetrically over the end of two pipes and the annular space between the inside of the collar and the outside of the pipe shall be filled with hemp yarn soaked in tar or cement slurry tamped with just sufficient quantity of water to have a consistency of semi dry condition, well packed and thoroughly rammed with caulking tools and then filled with cement mortar (1:2) prop. The joints shall be finished off with a fillet sloping at 45 degrees to the surface of the pipe. The finished joints shall be protected and cured for atleast 24 hours. Any plastic solution or cement mortar that may have squeezed in shall be removed to leave the inside of the pipe perfectly clean.

For more details of jointing procedure reference may be made to IS:783-1985.

7.1.4.3 C.I. PIPES

For C.I. pipes several types of joints such as rubber gasket known as Tyton joint, mechanical joint known as screw gland joint and conventional joint known as lead joint are used.

For details CPHEEO's Manual on Water Supply & Treatment and relevant Indian Standards may be referred to.

7.1.5 Hydraulic Testing of Pipe Sewers

7.1.5.1 WATER TEST

Each section of sewer shall be tested for water tightness preferably between manholes. To prevent change in alignment and disturbance after the pipes have been laid, it is desirable to backfill the pipes upto the top keeping atleast 90cm length of the pipe open at the joints. However, this may not be feasible in the case of pipes of shorter length, such as stoneware and RCC pipes. With concrete encasement or concrete grade, partial covering of the pipe is not necessary.

In case of concrete and stoneware pipes with cement mortar joints, pipes shall be tested three days after the cement mortar joints have been made. It is necessary that the pipelines are filled with water for about a week before commencing the application of pressure to allow for the absorption by pipe wall.

The sewers are tested by plugging the upper end with a provision for an air outlet pipe with stop cock. The water is filled through a funnel connected at the lower end provided with a plug. After the air has been expelled through the air outlet, the stop cock is closed and water level in the funnel is raised to 2.5m above the invert at the upper end. Water level in the funnel is noted after 30 minutes and the quantity of water required to restore the original water level in the funnel is determined. The pipe line under pressure is then inspected while the funnel is still in position. There shall not be any leaks in the pipe or the joints (small sweating on the pipe surface is permitted). Any sewer or part there of that does not meet the test shall be emptied and repaired or relaid as required and tested again.

The leakage or quantity of water to be supplied to maintain the test pressure during the period of 10 minutes shall not exceed 0.2 litres/mm dia. of pipes per kilometre length per day.

For non-pressure pipes it is better to observe the leakage for a period of 24 hours if feasible.

Exfiltration test for detection of leakage shall be carried out at a time when the ground-water table is low.

For concrete, R.C.C. and Asbestos cement pipes of more than 600mm dia. the quantity of water inflow can be increased by 10% for each additional 100mm of pipe dia.

For brick sewers, regardless of their dia., the permissible leakage of water shall not exceed 10 cubic meters for 24 hours per km. length of sewer.

7.1.5.2 AIR TESTING

Air testing becomes necessary particularly in large dia. pipes when the required quantity of water is not available for testing.

It is done by subjecting the stretch of pipe to an air pressure of 100mm of water by means of a hand pump. If the pressure is maintained at 75mm the joints shall be assumed to be water tight. In case the drop is more than 25mm the leaking joints shall be traced and suitably treated to ensure water tightness. The exact point of leakage can be detected by applying soap solution to all the joints in the line and looking for air bubbles.

7.1.6 Check for Obstruction

As soon as a stretch of sewer is laid and tested, a double disc or solid or closed cylinder, 75mm less in dimension than the internal dimension of the sewer shall be run through the stretch of the sewer to ensure that it is free from any obstruction.

7.1.7 Construction of Manholes

The manholes shall be constructed simultaneously with the sewers. The manholes shall normally be of brick-work in cement mortar 1:3 and plastered both inside and outside with 20mm thick cement plaster in cement mortar 1:3. The foundation of manholes shall be 15cm thick cement concrete of appropriate grade and thickness may be increased to 30cm when subsoil water is encountered, the projection of concrete being 10cm on all sides of the external face of brick work. The floor of the manholes shall be in cement concrete of appropriate grade. Salt glazed or concrete half channel pipes of the required size and curve shall be laid and embedded in cement concrete base to the same line and fall as the sewer. Both sides of the channel pipes shall be benched up in concrete and rendered smooth in 20mm thick cement mortar and formed to a slope of 1 in 10 to the channel. Bricks on edge shall be cut to a proper form and laid around the upper half of all the pipes entering or leaving the manhole, to form an arch. All round the pipe there shall be a joint of cement mortar 12mm thick between the pipe and the bricks. The ends of the pipes shall be built in and neatly finished off with cement mortar. The masonry shaft or the manhole shall be provided on the top with a heavy air tight cast iron frame and cover conforming to IS:1726 or any other approved type of frame and cover. Where the depth of the manhole exceeds 90cm below the surface of the ground, steps of cast iron or of any other approved material shall be built into the brick work. The distance between the two consecutive steps shall not be more than 40cm. The top of manhole shall be flush with the finished road level (IS:4111 Part I - 1967 Manholes).

The entire height of the manhole shall be tested for water-tightness by closing both the incoming and outgoing ends of the sewer and filling the manhole with water. A drop in water level not more than 50mm per 24 hours shall be permitted. In case of high subsoil water it should be ensured that there is no leakage of ground water into the manhole by observing the manhole for 24 hours after emptying it.

7.1.8 Sewer Connections

These shall be laid in the same manner as the sewer. In case the connection is at a level higher than 60cm., a vertical drop arrangement comprising of 90 degrees bend or a double tee junction encased in 1/2 brick thick brick work shall be provided. The drop arrangement shall be in brick work in cement mortar 1:3, plastered with 20mm thick cement plaster from outside in cement mortar 1:3. The lowest bend may preferably be of cast iron and the entire vertical pipe line encased in concrete. The top end of the drop arrangement in the manhole, when a tee is used, shall be plugged with brick work with a conspicuous mark there on so that in case a serious sewer choke occurs in the incoming line, this end can be made use off for roding purposes.

7.1.9 Backfilling of the Trenches

Backfilling of the sewer trench is a very important consideration in sewer construction. The method of backfilling to be used varies with the width of the trench, the character of the material excavated, the method of excavation and the degree of compaction required. In developed streets, a high degree of compaction is required to minimise the load while in less important streets, a more moderate specification for back fill may be justified. In open country it may be sufficient to mound the trench and after natural settlement return to regrade the areas.

No trench shall be filled in unless the sewer stretches have been tested and approved for water tightness of joints. However, partial filling may be done keeping the joints open to avoid disturbance. The refilling shall proceed around and above the pipes. Soft material screened free from stones or hard substances shall first be used and hand pressed under and around the pipes to half their height. Similar soft material shall then be put upto a height of 30cm above the top of the pipe and this will be moistened with water and well rammed. The remainder of the trench can be filled with hard material, in stages, each not exceeding 60cm. At each stage the filling shall be well rammed, consolidated and completely saturated with water and then only further filling shall be continued. Before and during the backfilling of a trench, precautions shall be taken against the floatation of the pipe line due to the entry of large quantities of water into the trench causing an uplift of the empty or the partly filled pipe line. Reference may be made to 6.3.2.4 for more details in this regard. Upon completion of the backfill, the surface shall be restored fully to the level that existed prior to the construction of the sewer.

7.1.10 Removal of Sheet piling

Sheet piling driven below the spring line of a sewer shall be withdrawn a little at a time as the back-filling progresses. Some of the backfilled earth is forced into the void created by withdrawing the sheet piling by means of a water jet. To avoid any damage to buildings, cables, gas mains, water mains, sewers etc., near the excavation or to avoid disturbance to the sewer already laid portions of the sheet piling may be left in the trenches.

CHAPTER 8

MAINTENANCE OF SEWERAGE SYSTEMS

8.1 INTRODUCTION

Quality maintenance of sewerage system consists of the optimum use of labour, equipment and materials to keep the system in good condition, so that it can accomplish efficiently its intended purpose of collection and transportation of wastewater to the treatment plant.

8.2 TYPES OF MAINTENANCE

There are two types of maintenance of a sewerage system - preventive and emergency. It is necessary that preventive or routine maintenance are carried out to prevent any breakdown of the system and to avoid emergency operations to deal with clogged sewer lines or over flowing manholes or backing up of sewage into a house or structural failure of the system. Preventive maintenance is more economical and provides for a reliability in operations of the sewer facilities. Emergency repairs, which would be very rare if proper maintenance is carried out will also have to be provided for. Proper inspection and preventive maintenance is a necessity.

8.3 NECESSITY OF MAINTENANCE

Sewer maintenance functions are too often neglected and given attention only as emergency arises. Adequate budgets are seldom provided for supervision, manpower and equipment, unlike the case for maintenance of other utilities like electric cables, telephone cables, gas and water mains. Such attitude towards sewer maintenance is found even in large cities. Considering the health hazards that the public at large has to face, it will be appropriate to provide sufficient funds to take care of men, material, equipment and machinery required for efficient maintenance.

All efforts should be made to see that there is no failure in the internal drainage system of a premises. A serious health hazard results when sewage backs up through the plumbing fixtures or into the basements. The householder is confronted with the unpleasant task of cleaning the premises after the sewer line has been cleaned. Extensive property damage may also occur, particularly where expensive appliances are located in the basements.

Maintenance helps to protect the capital investment and ensures an effective and economical expenditure in operating and maintaining the sewerage facilities. It also helps to build up and maintain cordial relations with the public, whose understanding and support are essential for the success of the facility.

8.4 ORGANISATION FOR MAINTENANCE

The organisation responsible for the maintenance of the sewerage system will vary with the size and type of the sewerage system and the relative age of the system. The larger the Municipality, the larger and more complex will be its maintenance organisation. The size of the organisation will vary from a couple of employees to several hundred regular employees. The primary effort of the staff is to maintain sewers free flowing and unobstructed.

The sewer system with its components properly designed and installed is handed over to the person in charge of maintenance who assumes the responsibility to make it function satisfactorily for the benefit of the community. One should have sufficient experience in the design and construction of the system to enable him to perform his task efficiently with an understanding and appreciation of the problems that may arise during maintenance. One has not only to be a technical man but has also to deal with human relations in order to be successful in his work. Inservice training shall be imparted

to the maintenance personnel to improve upon the methods adopted based on the latest trends. Failure to develop a better understanding of human relations and also lack of development of the concept of service to the community generally results in the maintenance part becoming unpopular. The general public is also to be made aware of do's and don'ts to help in keeping the sewers free flowing and unobstructed.

8.5 PROVISIONS IN DESIGN

Maintenance really begins with the design and construction of the sewerage system. Hence due consideration shall be given to maintenance requirements at the time of designing sewerage systems.

Since sewer maintenance has to commence from manholes which are located in the streets, the size of the manholes must be designed to permit safe access and sufficient working space. The sewers shall be laid at a sufficient grade to provide self cleansing velocity. Inverted siphons and eccentric manholes should be avoided wherever possible.

8.6 HOUSE CONNECTIONS

House connections or service connections to the public or municipal sewer should preferably be approved by the Maintenance Engineer. It is necessary to see that the fittings and pipes in the houses are according to the byelaws or rules or regulations in force. If such byelaws, rules or regulations are not existing, then reference may be made to the relevant IS code of practice. House connections may be of minimum size of 150mm in dia and should preferably be connected to the Municipal or Public sewer through a manhole. When 'Y' or 'T' connections are allowed, extreme care must be taken when breaking the sewer pipe line and inserting the Y or T saddle. Similarly, the connection to the manhole must be properly done and closed. Care has to be taken that brick bats or other materials of construction are not allowed to fall and lie in the manhole. It is this extraneous material that is largely responsible for persistent clogging of the sewer lines.

It should also be ensured that the house fittings are properly trapped not only to prevent the ingress of sewer gases into the houses but also to ensure that large objects do not find their way into the sewers. Similarly, it should be ensured that any liquid or material which is likely to be injurious to the material of the sewer line or to prejudicially interfere with its contents or be a hazard to the workmen engaged in the maintenance of the sewer lines, like very hot water, acids, chemicals etc., are not allowed.

8.7 PLANNING FOR SEWER MAINTENANCE

Sewer inspections and maintenance should be planned. The whole sewerage systems should be marked on a plan and divided into sections and areas, which are placed under a maintenance gang. The maintenance gang preferably consists of a supervisor or mate with atleast 6 skilled sewer men. The area under each gang will depend on the size of the sewer, depth to which it is laid, the spacing of manholes, the condition of sewer line (whether surcharged or not) whether cleaning is being done by manual labour or by mechanical sewer machines etc. In case, house gully traps are to be maintained, special gang of one or two persons who will clean these traps regularly in a phased or planned manner is necessary.

The work of each sewer maintenance gang would consist of the following:

- a) Check manhole condition for deposition of silt, flow, new connections done, damaged walls or steps, manhole covers, clogged vertical pipes in drop manholes etc. While the cleaning of the manhole, pipes etc., will be undertaken by the gang, repairs etc. may be reported to be handled by a separate construction gang of mason and helpers. It is preferable that the repair gang comes out on the work when the sewer cleaning or maintenance gang is working, so that brick bats, debris mortar etc., which fall in the

manhole are removed there and then. This will cause a major blockage if the same is allowed to flow into the sewer line, which usually occurs when repairs are done separately. In such cases, a couple of sewer men should be deputed to clean the manhole of the debris immediately after repair work is completed

- b) Check the sewer line between two successive manholes for silting and flow conditions and remove the deposited silt and
- c) Check for any harmful and extraneous matter entering into the sewer line so that further investigation for the cause and location can be determined
- d) Check air release valves in rising or force mains, sluice gates or stoppage in the sewer lines, overflow arrangements etc.

A record of daily work done by the gang, and also a record of work done on the sewer lines should be maintained so that chronic trouble spots may be investigated and remedial action taken.

8.8 SEWER CLEANING EQUIPMENT AND PROCEDURES

Sewer cleaning works require usual implements like pick axes, manhole guards, tripod stands, danger flags, lanterns, batteries, safety lamps, lead acetate paper, silt drums, ropes, iron hooks, hand carts, plunger rods, observation rods, shovels etc.

In addition, sewer cleaning work calls for the following special equipments and devices like a portable pump set running on either diesel or petrol engine, manila rope and cloth balls, sectional sewer rods, a sewer cleaning bucket machine, a dredger, a roding machine with flexible sewer rods and cleaning tool attachments such as augers, corkscrews, hedgehogs and sand cups, scraper, and hydraulically propelled devices such as flush bags, sewer balls, wooden ball and sewer scooters, sewer jetting machine, gully emptiers and pneumatic plugs.

8.8.1 Portable Pump Set

In cases where sewers are blocked completely and sewage has accumulated in manholes, the collected sewage has to be pumped out to tackle the sewer blockage. Such pumps should be of non-clogging type preferably on four wheel trailers for the larger sizes and should be provided with a self priming unit to save time and effort. Small pneumatic pumps can be used where high lifts are required and the volume of liquid to be pumped is not large, such as when pumping out flooded basements and dewatering deep trench excavations. In case of very deep manholes, non-clog submersible pumps may be used.

8.8.2 Manila Rope and Cloth Ball

The most common way of cleaning small diameter sewers upto 300mm dia is by the use of a manila rope and cloth ball. Flexible bamboo strips tied together are inserted into the sewer line by a person on top. If necessary, another man inside the manhole helps in pushing the rod through the sewer line. When the front end of the bamboo strip reaches the next manhole, a thick manila rope is tied to the rear end of the bamboo splits. The bamboo splits are then pulled by another man in the downstream manhole and pushed through the sewer line. As the rope is pulled, the ball sweeps the sewer line and the accumulated grit is carried to the next manhole where it is removed out by means of buckets. This operation is repeated between the next manholes until the stretch of sewer line is cleaned.

8.8.3 Sectional Sewer Rods

These rods are used for cleaning small sewers. The sewer rods may be of bamboo or teakwood or light metal usually about one meter long at the end of which is a coupling which remains intact in the sewer but can be easily disjointed in the manhole. Sections of the rods are pushed down the sewer. The front or the advancing end of the sewer rod is generally fitted with a brush, a rubber ring for cleaning or a cutting edge to cut and dislodge the obstructions. These rods are also useful to locate the obstruction from either manhole in case, that particular portion of the sewer has to be exposed for attending to the problem.

8.8.4 Sewer Cleaning Bucket Machine

The bucket machine consists of two powered winches with cables in between. In cleaning a section of sewer, the winches are centred over two adjacent manholes. To get the cable from one winch to the other, it is necessary to thread the cable through the sewer line by means of sewer rods or flexible split bamboo rods. The cable from the drum of each winch is fastened to the barrel on each end of an expansion sewer bucket fitted with closing device, so that the bucket can be pulled in either direction by the machine on the appropriate end. The bucket is pulled into the loosened material in the sewer until the operator feels that it is loaded with debris. The winch is then thrown out of gear and the opposing winch is put into action. When the reverse pull is started, the bucket automatically closes and the dirt is deposited in a truck or a trailer. This operation is repeated until the line is clear. Various bucket sizes are available for sewers of 150mm to 900mm in size. The machine is also used along with other scraping instruments for loosening sludge banks of detritus or cutting roots and dislodging obstructions (Fig.8.1).

8.8.5 Dredger (Clam-shell)

It consists of a grab bucket on a wire rope which is lowered into the manhole in open condition with the help of a crane and pulley. On reaching the bottom of the manhole the segments are closed, picking up the accumulated silt. The bucket is then raised above ground level where the bucket opens and the silt is automatically dropped into a truck or a trailer. The closing of the bucket can be effected by wire ropes or by a pneumatically operated cylinder. The disadvantage in this system is that it cannot clean the corners of the catchpits of manholes. Sometimes the deposits at the corners may become so hard that the same may be required to be chiselled out.

8.8.6 Roding Machine with Flexible Sewer Rods

This consists of a machine which rotates a flexible rod to which is attached the cleaning tool such as auger, corkscrew or hedgehog and sand cups (Fig.8.2). The flexible rod consists of a series of steel rods with screw couplings. The flexible rod is guided through the manhole by a bent pipe. The machine rotates the rod with the tool attached to one end, the other being fixed to the machine. The rotating rod is thrust into the bent pipe manually with clamps with long handles holding the rod near the couplings. As the rod is thrust inside, the machine also is drawn towards the manhole. The rod is pulled in and out in quick succession when the tool is engaging the obstruction, so as to dislodge or loosen it. When the obstruction is cleared, the rod is pulled out by means of clamps keeping the rod rotating to facilitate quick and easy removal. The various tools attached to the rods are shown in Fig.8.3

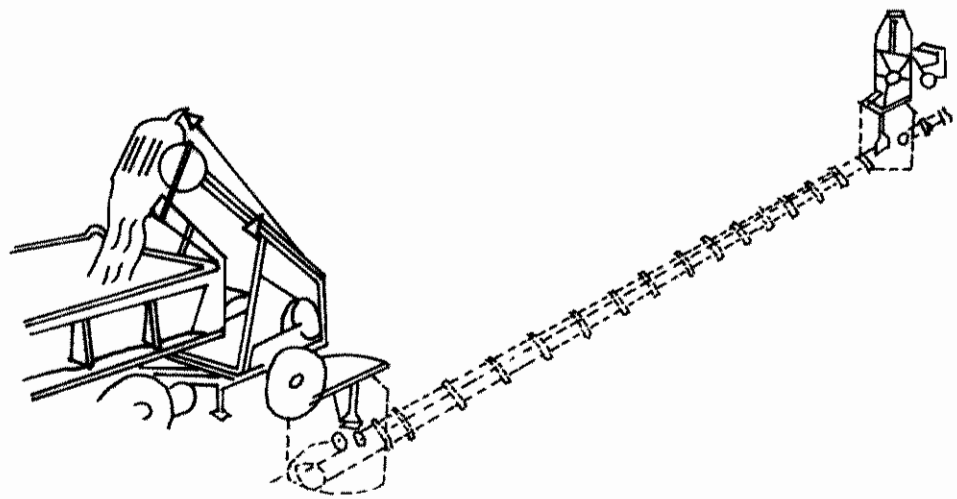

FIG. 8.1 : SEWER CLEANING BUCKET MACHINE

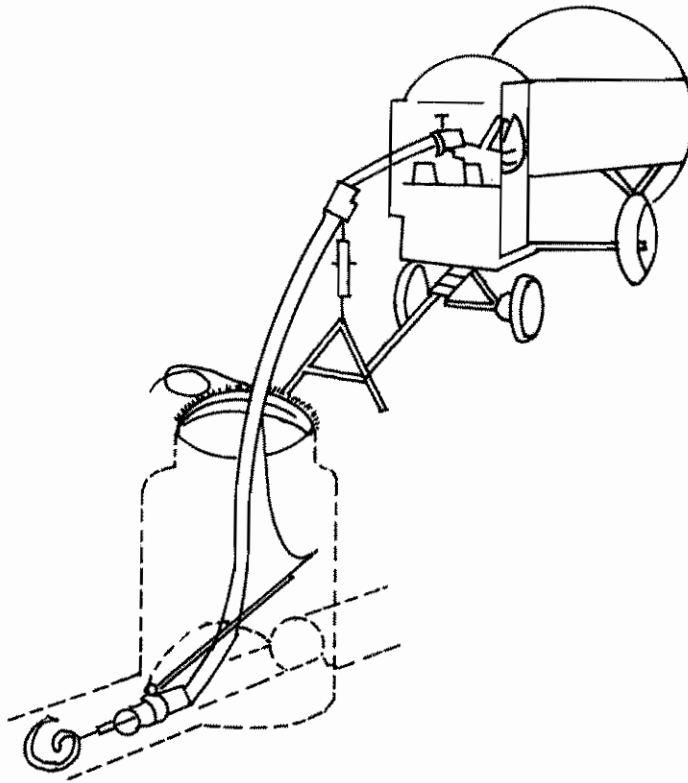

FIG. 8.2 : RODDING MACHINE WITH FLEXIBLE SEWER RODS FOR SEWER CLEANING

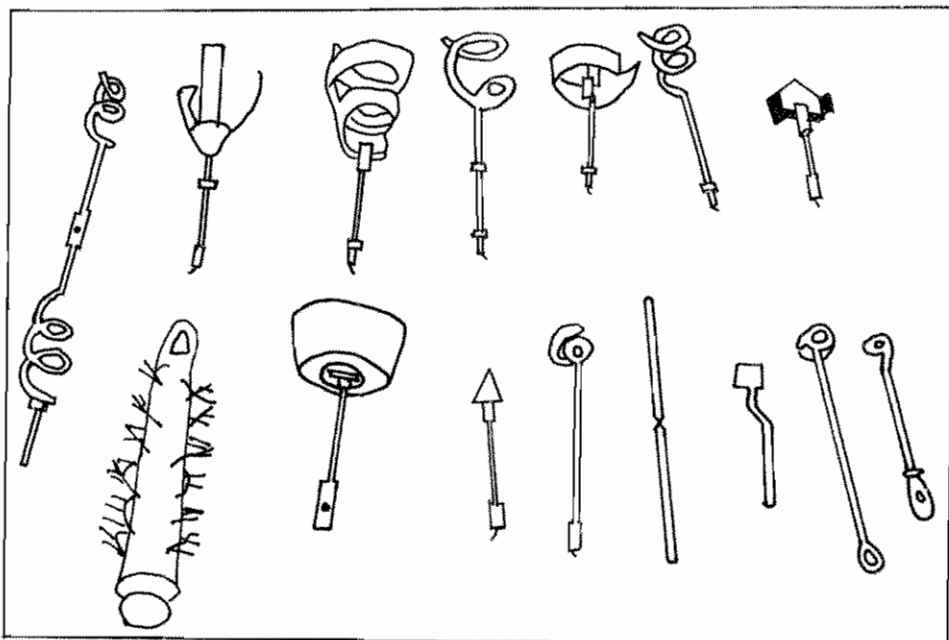

FIG. 8.3 : TOOLS FOR SEWER CLEANING

8.8.7 Scraper

This method is used for sewers of diameter larger than 750mm. The scraper is an assembly of wooden planks of slightly smaller size than the sewer to be cleaned. Where the scrapers cannot be lowered through the opening of a manhole, the scraper has to be assembled inside the manhole. The scraper chains, attached to a control chain in the manhole into which it is lowered, is then connected to a winch in the next downstream manhole by means of chains. The winch is then revolved to push the debris ahead of the scraper. The heading up of the flow behind the scraper and the water dropping from the top of the scraper will also assist in pushing it in the forward direction. This ensures that the bottom and the sides of the sewer are cleaned thoroughly. The scraped debris is removed manually.

Circular scrapers are used on small sewers below 350mm dia for cleaning the body of the line. They are commonly known as discs and these discs are either of collapsible type made out of metal or a wooden pair separated about 200mm apart by steel rods.

8.8.8 Hydraulically Propelled Devices

The hydraulically propelled devices take advantage of the force of impounded water to effectively clear sewers. Efficiency depends on the hydraulic principle that an increase in velocity in a moving stream is accompanied by a greatly increased ability to move entrained material. The transporting capacity of water varies as the sixth power of its velocity.

8.8.8.1 FLUSH BAGS

A most effective tool for cleaning portions of sewers where rods cannot be used is the sewer flusher or flush bag. The flusher is a canvas bag or rubber bag equipped with a firehose coupler at one end and a reducer at the other end. The flusher is connected to the firehose and placed in the downstream end from the point where a choke is located. The bag is allowed to fill up until it expands and seals the sewer. The upstream pressure built up due to this damming effect breaks loose the obstructions. Caution must be exercised in using these types of devices as there is a likelihood of sewage flowing back into the house connections or breaking of the pipes or joints due to high pressures that may develop.

8.8.8.2 SEWER BALLS

These are simple elastic pneumatic type rubber balls which can be blown upto varying degrees of inflation. They are manufactured in sizes from 150mm to 750mm dia when fully inflated. When used in cleaning a sewer, the ball is first inflated and then wrapped in a canvas cloth, the edges of which are sewed together. A trial line, little longer than the distance between the manholes, is attached securely to the covering. The size of the ball and the covering shall be such as to fit fairly snugly into the sewer. Immediately the ball is thrust into the sewer, sewage commences to back up in the manhole and continues to rise until such time as its pressure is great enough to force sewage under the ball and moving it downstream through the pipe. Acting as a compressible floating plug, it affords enough obstruction, so that a continuous high velocity jet spurts under and to some extent around the ball, thereby sluicing all the movable material ahead to the next manhole. If the ball encounters an obstruction which is immovable, the ball merely indents to the necessary degree and moves forward. The only fixed obstructions which will stop the forward progress of the ball is a root mass or some similar obstruction tightly wedged into the pipe. Bricks, stones, bottles, loose metal parts, broken pieces of pipes, sand, gravel and settled sludge are easily moved ahead. If the ball stops momentarily, a pull on the trial line is usually sufficient to set it in motion again. If the pipe is very dirty, the trial line can be tied to a step in the upper manhole and the ball's progress can be retarded to the required degree as the lower manhole is reached, thus giving time for complete removal of accumulated silt and debris which has piled up ahead of the ball (Fig.8.4).

A wooden ball, also called a sewer pill, can also be used for this purpose, particularly for cleaning large outfall sewers. It is dropped into the sewer and owing to its buoyant action rolls along the invert of the sewer. The obstructions caused by it to the flow produces a vigorous scouring action along the invert and the sides which has the effect of removing the growths and the deposits from the sewers. This method is economical and hence can be used at frequent intervals.

8.8.8.3 SEWER SCOOTERS

This arrangement is an improved version of the scraper and consists of two jacks, a controlling rope and the scooter with a tight fitting shield. In contrast to the scraper, the scooter completely stops any flow of sewage. The scooter, attached to the control rope, is lowered into the manhole and then into the downstream sewer line. The downstream manhole jack is lowered into place from the road and the upper manhole jack set across the top of the manhole.

When the scooter is introduced into the line, it stops the flow of sewage thus building up a head behind the shield. The resulting pressure causes the scooter to move through the sewer until it accumulates enough debris to stop its movement. The head is then allowed to build up approximately one meter before the control rope is pulled, causing the shield to fold back, thus allowing the accumulated sewage to gush into the sewer downstream, flushing the debris ahead to the next manhole from where it is removed. The control rope is released, clearing the shield against the sewage and causing the scooter to advance again until the debris stops its movement. This process is repeated till the scooter reaches the downstream manhole where it may be removed or allowed to continue through the next section.

8.8.9 Velocity Cleaners (Jetting Machines)

The high velocity sewer cleaner makes use of high velocity water jets to remove and dislodge obstructions, soluble grease, grit and other materials from sanitary, storm and combined sewerage systems. It combines the functions of a roding machine and gully emptier machine. Basically it includes a high pressure hydraulic pump capable of delivering water at variable pressure upto about 80 kg/cm^2 through a flexible hose to a sewer cleaning nozzle. The nozzle has one forward facing hole and a number of rear ward facing holes. The high pressure water coming out of the holes with a high velocity breaks up and dislodges the obstructions and flushes the materials down the sewer. Moreover by varying the pressure suitably, the nozzle itself acts as a jack hammer and breaks up stubborn obstructions. (A separate suction pump or air flow devices may also be used to suck the dislodged material).

The entire equipment is usually mounted on a heavy truck chassis with either a separate prime mover or a power take off for the suction device. The high pressure hose reel is also hydraulically driven. The truck also carries fresh water tanks for the hydraulic jet and a tank for the removed sludge and the various controls grouped together for easy operation during sewer cleaning. The manufacturer's operating and servicing manuals should be carefully followed for best results in the use of the machine.

8.8.10 Suction Units (Gully Emptier)

Suction units create vacuum required for syphoning of mud, slurry, grit and other materials from sanitary, storm and combined sewerage systems. The vacuum created is such as to syphon the materials from the deep manholes catch-pits etc. having depth ranging from 1m to 8m in normal cases with an option to suck additional 4m with the help of special accessories for the purpose. The unit can be vehicle or trolley mounted.

Silt and heavy particles settled at the bottom can be agitated and loosened by pressurised air with the help of the pump and then sucked in a tank. Once the silt tank is full, the effluent is discharged in the nearby storm water drain or manhole and the operation is repeated till the manhole is cleared off the silt. The silt deposited in the tank is then emptied at the predetermined dumping spot.

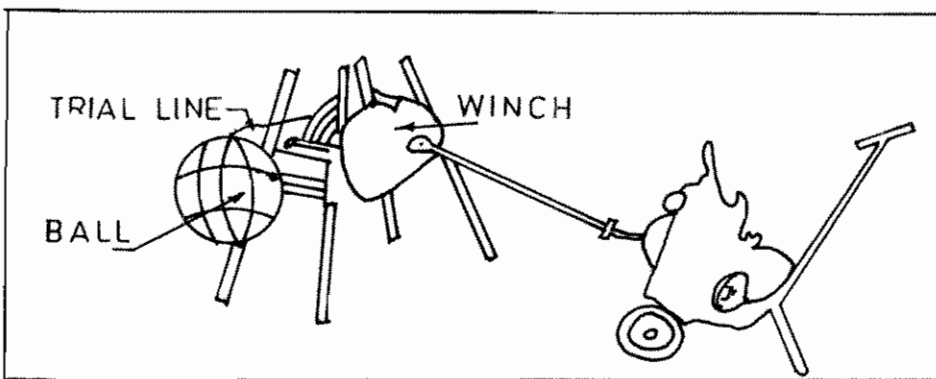

FIG. 8.4 : SEWER BALL WITH MECHANICAL ARRANGMENT FOR SEWER CLEANING

This machine is very much useful in desilting surcharged manholes and in routine course the manholes can be desilted without the workers getting down into the manhole.

8.8.11 Pneumatic Plugs

The plugs are used for:

1. Isolating the gravity sewers for low pressure testing of sewer
2. Stopping the flow of sewage in the sewer line to carry out structural repairs
3. Stopping the flow to carry out routine maintenance on the downstream side of plugged sewer line.

The plugs are made of metal plates which can withstand the action of wastewater. The plates are bonded with suitable quality strong elastic material. The plugs should withstand the minimum hydrostatic back pressure likely to be encountered. The plugs can be inflated and deflated within the sewer line itself by suitable controls from the road level. Suitable hook and chain are provided to chain the plug in the manhole. Tethering life line and inflation hose are supplied with each plug. All plugs above 450mm dia should have a bye-pass fitting suitable for fixing a fire hose and suction hose.

8.9 HAZARDS

Personnel engaged in operation and maintenance of sewerage systems including sewage pumping stations are exposed to different types of occupational hazards like physical injuries, injuries caused by chemicals and radioactive wastes, infections caused by pathogenic organisms in sewage and dangers inherent with explosive or noxious vapours and oxygen deficiency.

The health and safety of personnel can be safeguarded to a great extent by taking the likely hazards into consideration at the time of designing the sewers, sewer appurtenances and pumping stations. Hazards which are still possible inspite of due consideration being given at the design stages, can be reduced by use of safety equipment and precautions appropriate for each hazardous condition. Finally to guard against human error and carelessness, proper job instructions and adequate effective supervision by competent personnel are most essential.

8.9.1 Gases In Sewerage System

Sewer gas is a mixture of gases in sewers and manholes containing abnormally high percentage of carbon dioxide, varying amounts of methane, hydrogen, hydrogen sulphide and low percentages of oxygen caused by septic action through the accumulation of organic matter inside the sewer. The actual hazard is due to the presence of high levels of methane, forming an explosive mixture or the oxygen deficiency or hydrogen sulphide in excess of permissible levels. Some times trade wastes may also contribute to other gases like chlorine, ammonia, sulphur dioxide etc.

The characteristics of common gases encountered in sewers, sewage pumping stations and sewage treatment plants, their physiological effects and safe exposure limits are detailed in Appendix-8.1

A noxious gas or vapour is any gas or vapour that is directly or indirectly injurious or destructive to the health or life of human beings. It can be a simple asphyxiant, chemical asphyxiant, irritant, volatile solvent or a combustible gas.

Simple asphyxiants are the physiologically inert gases like nitrogen, carbon dioxide, methane and hydrogen which when breathed in high concentrations act mechanically by excluding oxygen.

Chemical asphyxiants are substances like carbon monoxide which by combining with the haemoglobin of the blood or with some constituents of the tissues either prevent oxygen from reaching the tissues or prevent the tissues from using it.

Irritants are substances like chlorine which injure the air passage and lungs and induce inflammation in the surface of the respiratory tract.

Volatile solvents and drug-like substances exert little or no effect on the lungs but affect the nervous system inducing anaesthesia. Inorganic and organic metallic poisonous substances in a volatile form prove toxic after their absorption into the body.

Combustible vapours will burn as long as they are in contact with flame, spark or a heated material having a temperature equal to or greater than the ignition temperature of the gas or vapour provided, there is enough oxygen present for combustion. The reaction of the gas or vapour with the oxygen of the air, resulting in progressive combustion, or propagation of flame, occurs only when the concentration of the gas or vapour is within certain limits expressed as percentage of gas or vapour in air by volume. These limits are called explosive limits. Outside these limits, local combustion may occur at the source of ignition but there will be no propagation of flame and hence the combustion ceases on removal of the source of ignition. Within the limits, alongwith the propagation of the flame through the mixture, there will be development of pressure leading to violent explosion.

8.10 PRECAUTIONS

8.10.1 Traffic Control

- a) Place easily readable and clear warning signs well ahead of work area
- b) Fence off adequate space around the manhole for placing equipment and deposition of silt removed
- c) Place barricades or signs to channelise the traffic, if possible
- d) Vehicles can be parked between the traffic and the work area
- e) Use a flagman at the two ends for controlling flow of traffic from each direction and to avoid a traffic jam, if the road is narrow and only one lane of traffic is possible.

8.10.2 Manhole Safety

- a) Ventilate the sewer line by opening two or three manholes on both the sides where work is to be carried out. This is more important when adequate blowers for ventilating sewers are not available. The manholes should be opened at least one hour before start of operations. The opened manholes should be properly fenced to prevent any person, especially children, accidentally falling into the sewer. Dummy covers with BRC welded fabric can be used
- b) Where it is desirable to use the blowers, operate these for at least 30 minutes before start and during cleaning operations to ventilate the lowest working levels
- c) Use safety harness and life line before entering the sewer line. Two helpers at the top should be provided for each person. The person standing at the top must send signals at every few minutes interval to the person in the manhole to ensure safety
- d) Test for hazardous gases before entry of a person into the sewer line and also in between if the operations are for a longer time

- e) Test manhole rungs or steps for structural safety before using
- f) Ensure that, where portable ladders are used, they are properly seated or fixed
- g) Ensure that no material or tools are located near the edge which can fall into the manhole and injure the workman
- h) Lower all tools to the workman in a bucket
- i) Use lighting equipment which must be explosion and fire proof
- j) Use Gas masks when men have to enter into the sewer line.

8.10.3 Infection

The personnel working in sewerage maintenance systems are prone to infections and hence the following precautions should be taken :

- i) emergency first aid treatment kits shall be provided to take care of all minor injuries like cuts and burns
- ii) a physician's services should be available for emergencies
- iii) the workers should be educated about the hazards of waterborne diseases such as typhoid and cholera through sewage and tetanus through cuts and wounds. Preventive inoculations should be given periodically to the workers
- iv) the importance of personal hygiene should be emphasized and the workers should be instructed to keep finger nails short and well trimmed, wash hands with soap and hot water before taking food and to keep fingers out of nose, mouth and eyes, because the hands carry most infections
- v) use of rubber gloves should be insisted so that sewage or sludge does not come in direct contact with the hands
- vi) the workers should be provided with a complete change of work clothes to be worn during working hours. Gum boots should also be provided for the workers
- vii) in laboratory work, only pipettes with rubber teats should be used to prevent contamination of the mouth. Laboratory glassware should not be used for drinking purposes. In no event food should be prepared in the laboratory.

8.10.4 Precautions of Pumping Stations

- a) Guards, shields, fencing, railings, enclosures should be designed to help prevent slipping, falling or contacting machinery while in operation. Replace or repair if they are missing or damaged. When removed instal a temporary safety barrier
- b) When dealing with equipment
 - i) Always stop the machine before removing any guard
 - ii) See that power supply to the equipment is cut off. Place a warning board on the switch so that some body does not accidentally put it on

- iii) Hoisting equipment should be able to lift the required load. Temporary support should be given to any machine or equipment jacked or hoisted up before going under it
- iv) Keep tools in a bag or in a belt and not on the floor
- v) When lubricating a machine in operation, fittings should be atleast 30 cms. from any moving part or piped outside a guard
- vi) If oil or grease is split, clean up at once.

8.10.5 Precautions Against Electrical Shocks

- a) Only qualified and specially trained personnel should be allowed to operate and maintain electrical equipment at the pumping stations
- b) All electrical controls should be kept dry and in good condition
- c) No metal ladders or metal tapes should be used around electrical equipment
- d) Insulated rubber mats should be provided before all electrical control panels and they should be kept dry
- e) Always test wires for current before working on any electrical item. Use tools with insulated handles and rubber gloves.

8.11 SAFETY EQUIPMENT

The various safety equipments that are normally required in sewer maintenance work are gas masks, oxygen breathing apparatus, portable lighting equipment, nonsparking tools, portable air blowers, safety belts, inhalators and diver's suit.

The use of the particular safety equipment is governed by the detection of various gases and oxygen deficiency.

A knowledge of the type of gases in the atmosphere and of the working location becomes essential for the selection of the right type of safety equipment. Equipment and simple tests for detection of various gases and oxygen deficiency are furnished in Appendix 8.2.

8.11.1 Gas Masks

General purpose gas masks are used for respiratory protection from low and moderately high concentrations of all types of toxic gases and vapours present in the atmosphere in which there is sufficient oxygen to support life. Masks afford necessary respiratory protection under many circumstances but it is most important to know the limitations of the various types available and to be familiar with their use. Even when masks are used properly, other precautions such as never using open flames or creating sparks in the presence of inflammable gases must be taken. The general purpose gas masks affords protection against organic vapours, acid gases, carbon monoxide upto 2 percent concentration, toxic dusts, fumes and smoke.

The gas mask consists of a face piece, a canister containing purifying chemicals, a timer for showing duration of service and a harness for support. Protection against specific contaminants can be achieved by the selection of appropriate canisters.

Persons using gas masks should practise regularly with them in order to become proficient in putting them on quickly and breathing through them.

Gas masks cannot be used in oxygen deficient atmospheres, in unventilated locations or areas where large concentrations of poisonous gases exist.

8.11.2 Breathing Apparatus

This is designed for respiratory protection from atmosphere that contains very high concentrations of toxic gases and vapours or that are deficient in oxygen. It fully protects a worker against all gases, vapours, dusts, fumes, smokes and oxygen deficiencies and can be safely used in petroleum vapours and is the most dependable device for work in atmospheres normally encountered in sewage works.

8.11.2.1 AIR HOSE RESPIRATOR

This is used where a source of fresh air is available within a distance of 50m from the working location. It is essential that the supply of air is obtained from an uncontaminated source.

It consists of a mask which is a tight fitting face piece attached to a large diameter flexible hose, breathing tubes and a harness. Fresh air is blown to the mask through either a power operated or a hand operated blower. An inhalation check valve in the breathing tube assembly and exhalation valve in the face piece permit air flow only in one direction, from the source to the mask, when the blower is in operation. Exhaled air is released into the surrounding atmosphere through the exhalation valve. The valve arrangement permits the wearer to breathe directly through the hose in the event of blower failure. The maximum length of hose will be about 50 M. The hose, being of large diameter, permits breathing without excessive resistance in the event of blower failure. A special pressure release valve on the blower permits regulation of air delivery and a fresh air bypass valve functions automatically in the event of blower failure permitting the wearer to breathe directly through the hose. When a hand operated blower is used the operator will be available to attend to any emergent situation also. This apparatus does not depend on chemical and may be used over extended periods at low costs.

Purified air is used where a source of fresh air is not available within 50 m to permit the use of an air hose respirator or in situations where an air hose would encumber the worker.

8.11.3 Portable Lighting Equipment

The equipment normally used are portable electric hand lamps of permissible types, electric cap lamps and explosion proof flash lights.

8.11.4 Nonsparking Tools

These are made of an alloy (containing atleast 80 percent of copper) that will not spark when struck against other objects and metals and yet retains the necessary strength and resistance to wear.

8.11.5 Portable Air Blowers

Forced ventilation of manholes, pits and tanks can be provided by portable air blowers. Special precautions should be taken to ensure that the blowers do not serve as a source of ignition for inflammable gases. Such precautions shall include placing of the blower upwind from the manhole or at right angles to the wind direction and atleast 2 m away from the opening. The use of such equipment requires a consideration of the depth of the manhole, size of enclosure and the number of openings to uncontaminated atmosphere. Trailer mounted blower having a capacity of 210 m³/min can ventilate easily many metres of medium sized sewers.

8.11.6 Safety Belt

This consists of a body belt with a buckle and a shoulder harness. The life line is of high grade spliced manila rope, nylon rope or a steel cable anchored with rings on each side of the belt and provided with safety straps for anchoring or securing to a stable support. The life line should be about 15 m in length and the overall assembly should be capable of withstanding a tensile load of 2000 Kg. The safety belt and life line should be tested by lifting the wearer clear of ground before each day's use.

8.11.7 Inhalators

Approved inhalators employing a mixture of oxygen and carbon dioxide are used for resuscitating victims of gas collapse, drowning or electric shock. Artificial respiration should be started at once on the patient and an inhalator face piece attached to the victims mouth as soon as the equipment can be made ready. The carbon dioxide used in small percentages stimulates deep breathing so that more oxygen may be inhaled. Pure oxygen should be used only when irritant gases such as hydrogen sulphide or chlorine have caused the victim's collapse.

8.11.8 Diver's Suit

A good quality diver suit should be provided to the diver whose services are very necessary while plugging the sewer line or removal of some hard blockage due to stone etc. at the mouth of the pipe in the manholes. Depending upon the site condition, suit should have provision to connect an air line with compressor or oxygen cylinder.

8.12 EMERGENCY MAINTENANCE

Emergency maintenance becomes necessary for removal of obstructions in sewers caused by excessive silt accumulation or damage leading to the break down of the system with flows much lower than the normal.

The sewer gang for this type of work should consist of specially trained men who are aware of the hazards and capable of coping with situations calling for prompt action. The supervision in this case should be entrusted to a responsible person well-versed in the use of the special sewer cleaning equipment, safety equipment and in first aid.

For locating the exact position of blockages, it is necessary to commence observation from the overflowing manholes down the line until the first manhole with little or no flow is reached. The section between this manhole and the one immediately upstream is the one which is blocked and requires to be tackled.

In the case of simple blockages, the split bamboo rods can be effectively used. The end of the bamboo rod is tied with cloth to make a small ball of 30 to 50mm thick and is inserted into the sewer line from the lower manhole where there is little or no sewage flowing. The bamboo rods are then inserted and pushed until the place of blockage is reached. The rod is then pulled out a little and struck against the blockage with a jerk. This is repeated a number of times till the blockage is removed. In case of a persistent blockage, flexible bamboo splits are inserted from the upper manhole also. This can be done by an experienced person even though the manhole is filled with sewage. The operation of striking against the blockage is carried out simultaneously from both ends continuously till it is removed.

Sectional sewer rods with a cutting edge are also used where available. A ferret in conjunction with a fire hose is also used for removing sand blockages. Sewer jetting machines and gully emptiers are successful and effective also in removing blockages.

When the above methods are not successful or damage to the sewer is suspected, the location

of the blockage can be found by the use of sectional rods from either end of the blocked sewer. Once this is located, the sewer length near the blockage can be exposed by open excavation to examine and set right the sewer line. Before puncturing the sewer line, foundation concrete for a new manhole is laid and the walls of the manhole are raised to a height to contain the sewage. The sewer is then punctured and the headed up sewage flows down to normal, after which the top of the sewer is completely broken and a channel formed in the manhole. The sides of the manhole are then raised up to the ground level and the manhole completed as in normal construction.

If the damage to the sewer is extensive and is caused by poor foundation then the stretch between the two manholes may have to be relaid on a proper foundation.

In the case of a small diameter sewer which is broken to remove the blockage, repair can be affected by using a piece of pipe one size larger than the one being repaired. The patch should be the shape of the cut and near the same size and should be well cemented on with cement mortar.

8.13 INSPECTION

8.13.1 Necessity for Inspection

A designer's misjudgment and the construction man's carelessness are directly responsible for many of the sewer failures. Due to age, deterioration of the material of the sewer by the attack of hydrogen sulphide or other chemicals, settlement of foundations and leaking joints may result in the structural failure of the sewer. It takes a very long time from the onset of the first initial defect to the collapse of the sewer. A crack or a leaking joint will allow subsoil water and soil to enter into the sewer causing cavities round it leading to slow settlement of foundation and the eventual collapse of the sewer. Very often soil with water is carried away below the bedding along the length of the sewer. The type of break often gives a clue to the cause. A shear failure, due to faulty foundation or movement of earth, is a clean vertical break in the pipe or barrel. Horizontal breaks are caused by excessive loading, either internally or externally. Breaks caused by internal pressure gives cracks in the sewer while external overload causes the top of the pipe to crush. Regular inspection of the sewer can pinpoint the sewer that needs to be attended to before there is a complete failure or collapse.

8.13.2 Type of Inspection

In order to assess the condition of the sewers inspections are necessary.

There are two basic types of inspection:

- i) Direct
- ii) Indirect

8.13.3 Direct Inspection

Direct inspection is carried out manually by crawling or walking through the sewer line. Direct inspection can be carried out in sewers above 500 mm dia. where a man can crawl through. Above 900 mm diameter, a man can walk through.

8.13.4 Indirect Inspection

Indirect inspection is carried out by sending a camera through the sewer for taking photographs or a closed circuit television equipment (CCTV) to send pictures which can be seen on a TV Screen or recorded on a video tape. The CCTV inspection can be used for sewer lines as small as 100mm. Above 900mm diameter there are limitations due to lighting problems and camera line angles.

Continual advances in range of TV cameras and also in quality are being made. The type of

camera selected should be robust for use in sewers and be able to give good quality pictures.

Traction of the cameras is by pulling winches, by pushing or self traction. The former two are not used much at present. However, self traction is suitable for use in sewers above 225mm diameter. Other constraints in the use of self traction is the weight of the trolley and electricity requirements. Heavy silting of sewers preclude the use of self traction. The cameras are attached to trolleys or mounted on pair of skids or single flat tray.

Inspection of the sewer by CCTV is limited to the top portion only. The objects under scrutiny are parallel to the camera and viewing is at 40 to 50 degrees. With radial scanning head, inspection normal to the sewer wall is possible.

8.13.5 Planning for Sewer Inspection

Very old sewers are the ones that are likely to give trouble and require to be inspected. However, this may not always be the case and there are instances when even newly laid sewers have given trouble.

An experienced maintenance engineer will be able to identify critical sewers which require to be inspected in the first phase. If proper watch is kept during the sewer cleaning operations it will be possible to observe damages to manholes due to deterioration in the joints and collapse of bricks and/or removal of bricks and soil by the sewer cleaning machines regularly from the same area. These may be the early warning signs of an impending disaster. Settlement of road surfaces, pollution of water by sewage, high chloride contents of the subsoil water are other signs indicating leaking joints or cracks in the sewers. History of previous collapses of sewer lines will also indicate the priority areas for sewer inspection.

A list of such critical areas should be drawn up and a programme of sewer inspection chalked out. Other areas singled out for sewer inspection would be the heavily built up and congested areas where a sewer failure would have very severe repercussions.

8.14 SEWER REHABILITATION

Sewers which are determined to be critical after inspection, have to be taken up for rehabilitation. Sewer rehabilitation is necessitated either to improve the hydraulic performance of the existing line or due to danger of the sewer line deteriorating further and leading to eventual collapse or failure.

8.14.1 Methods

Sewer rehabilitation may be carried out by renovation or by renewal of the sewer.

When the condition of the sewer is improved either to increase its carrying capacity or to increase its life, it is known as renovation.

When the sewer line is reconstructed or replaced to the same dimensions as existing, it is known as renewal.

8.14.2 Sewer Renovation

In the renovation of sewers, the original sewer fabric is utilised and improvements carried out. The various methods utilised are:

- a) Stabilisation where painting or chemical grouting of the joints is carried out
- b) Pipe linings in which pipes of slightly smaller diameter than the sewer are inserted.

Pipes may be of Glass Reinforced Plastic (GRP) and HDPE or MDPE which can be butt fusion welded

The insitu tube, manufactured of polyester felt and impregnated with a resin mixed with a special catalyst is tailored to suit the internal diameter/dimension of the pipe. The insitu tube is inserted from any manhole, opening etc. During insertion, the tube turns inside out so that the polyurethane side forms the inside surface of the pipe. Water is pumped into the tube to a predetermined head and the tube travels down the pipe to be repaired. As the insitu tube travels, the pressure of the water firmly presses the resin impregnated side against the pipe wall. When the insitu tube reaches the downstream manhole, addition of water is stopped and the water heated to cure the resin. The result is a cast in situ pipe within a pipe. Alternative method of pulling the tube in and then inflating it is also used for small diameter pipes. Recent development is the use of photo curing resins i.e. curing by light.

- c) Segmental linings of glass reinforced cement, GRP, resin concrete and precast gunite are used when man entry is possible
- d) Coatings by insitu grouting

When linings are used, annulus grouting is necessary in majority of the cases for a satisfactory performance.

8.15 SAFETY PRACTICES

An uptodate record of the fatal injuries, injuries causing permanent disabilities and those causing temporary and total disabilities in the sewerage industry may not be available. However, it is known that the number of such injuries is large. Besides pain and suffering caused, the financial cost to the injured and the authorities is tremendous. Hence, there is a need for a safety practice programme.

8.15.1 Safety Practice Programme

It is necessary that a person in the authority responsible for sewerage facilities should be made responsible for the programme. In a smaller authority, it may be the Engineer or Superintendent Incharge of the works while in large organisations, a person who can devote part or full time to the job may be so designated.

The safety practice programme would provide for:

8.15.2 Keeping Records of Injury

This is most important. Special formats can be worked out and it may include for the following:

- i) Accident report
- ii) Description of the accident
- iii) Report of Doctor
- iv) Corrective action taken
- v) Accident analysis

8.15.3 Searching out Hazards

The person responsible for the programme must constantly review and look out for hazards that may be responsible for injury to a workman. Safety manuals, insurance companies policy brochures etc. are some of the sources from which information can be gathered.

8.15.4 Safe Equipment, Working Methods

It is necessary to eliminate causes due to which accidents occur by replacement of faulty equipment or provision of safety equipment. Methods of working or site conditions can be improved. Protective equipment like helmets, boots, gloves etc., should be provided.

8.15.4.1 MOTIVATION AND TRAINING

It is necessary that the employees are motivated to get them trained in the safety practice programme.

8.15.4.2 CHANGING WORKING HABITS

While a job may be done in several ways, it is necessary to identify and insist on a safe method. This would include proper use of tools i.e. selecting the right tool and using it properly. Good footing to prevent slipping, not using tools near moving machinery, not leaving tools at high places where they may fall on a workman below are some examples of working habits.

8.16 RECORDS

8.16.1 Maps and Profiles

Uptodate maps and profiles of the sewerage system are a must not only for the proper maintenance of the system but also for assessing its adequacy. Unfortunately, most of the cities do not have any such maps and if they have them, they are outdated.

In many places in a city, due to relocation, repair or upgrading of roads, the manhole covers are not traceable. It is possible to relocate the same by utilising the knowledge of old workmen and owners of near by properties. Equipment for locating hidden manhole frames and covers are available and can be used.

After location of the various manholes, mapping of the sewers should be carried out. A special task force can be employed for this purpose or the work entrusted to specialised firms having the necessary equipment and knowledge.

Where, however, this cannot be done, records can be prepared by using the sewer cleaning and maintenance gangs. These gangs when attending to any cleaning work or complaint can measure the depth of the manhole and also the size of the sewer, which information can be recorded in the office and maps slowly built up. A record of House Service Connections in the sewerage system may be obtained.

8.16.2 Data

Records should be maintained of:

- a) All complaints received regarding sewer blockages or stoppages and clearance of the same with dates and times
- b) The condition of the sewer found at the time of attending to the complaint, damage, noticed, if any, should be recorded by the attending staff
- c) The record of cleaning of the sewers should be maintained by the staff/gangs responsible for the same
- d) All data regarding the construction, repair, rehabilitation of sewers.

SEWAGE AND STORM WATER PUMPING STATIONS

9.1 GENERAL CONSIDERATIONS

Pumping stations handle sewage/storm-water either for lifting the sewage so as to discharge into another gravity sewer or for treatment/disposal of the sewage/effluent.

Pumping for drainage is necessary, where gravity drainage is either not feasible as in low-lying localities and areas close to the sea-shore or gravity drainage is not economical, because of the cost of excavation, especially if a sewer has to pass across high spots like hillocks between the area to be drained and the point of discharge.

The availability of land, scope of expansion, the type of equipment to be used and their arrangement, the structure, its external appearance and general aesthetics are the basic considerations in the design of pumping stations.

9.2 LOCATION

Proper location of the pumping station requires a comprehensive study of the area to be served, to ensure that the entire area can be adequately drained. Special consideration has to be given to undeveloped or developing areas and to probable future growth, as the location of the pumping station will often be determined by the future overall development of the area. The site should be aesthetically satisfactory. The pumping station has to be so located and constructed that it will not get flooded at any time. The storm-water pumping stations have to be so located that water may be impounded without creating an undue amount of flood-damage, if the flow exceeds the pumping station capacity. The station should be easily accessible under all weather conditions.

9.3 CAPACITY

The capacity of the station has to be based on present and future sewage-flows, considering a design-period of 15 years. The civil structure and pipeline of both the dry sump and the wet well should be designed for a flow 30 years hence. The needs of future-expansion need special attention, especially in respect of provision of additional space for replacing the smaller pumping units by larger ones, increasing the capacity of the wet well and constructing new pumping stations to cope with the increased flows. The initial flows are generally too small and the effect of the minimum flow should be studied before selecting the size of the pumps for the project to be commissioned, in order to avoid too infrequent pumping operations and long retention of sewage in wet wells.

9.4 TYPES OF PUMPING STATIONS

Pumping stations traditionally have two wells, the wet well receiving the incoming sewage, having alongside a dry well housing the pumps. Use of wet-pit pumps does not need the dry well. Wet pit pumps are installed vertically either mounting the motor on the floor above the ceiling of the wet well or using submersible pumps.

When both the wet and dry wells are to be provided, these may be of any of the following types:

- i) rectangular, with dry and wet wells adjacent to each other
- ii) circular with central dry well and peripheral wet well and
- iii) circular with a dividing wall to separate the dry and wet wells.

9.5 STRUCTURE AND LAYOUT OF THE PUMPHOUSE

The site should be adequately protected from flooding. The structure must be designed to withstand floatation forces. Isolated pumping stations, particularly unmanned should be protected against vandalism. The site should be aesthetically satisfactory. The dry wells should have a separate entrance. For easy access to the sub-structure of wet wells, cast iron steps should be provided. Alternatively, portable aluminium ladders may be used.

Both the dry and the wet well are generally of R.C.C-Construction. IS:3370 and IS:4111 (Part 4) shall be followed for their design and construction. In many parts of the country, especially in the arid western regions, the ground-water contains very high concentrations of sulphates leached from the soils, which may cause corrosion. Under these conditions sulphate-resistant cement should be used in the concrete.

9.5.1 Provision of Essential Accessories

At all sewage pumping stations, flow-measuring devices such as venturimeter shall be provided. The throat of the venturimeter should be a hard metal so that it would not get abraded fast by the grit and sand entraining in the flow. The abrasion would give incorrect reading.

9.5.2 Provisions for Functional Requirements

9.5.2.1 VENTILATION

Since toxic gases emanate from the sewage, it is necessary to ensure proper ventilation for hazard-free working in the stations. Normally 8 to 12 air-changes per hour are recommended to be provided. For dry wells upto 4 m depth, natural inlet with exhaust fans can be used. If the depth of dry well is more than 4 m below Ground Level and for the wet wells, force inlet and forced outlet may be used. Such ventilation is mandatory as per the safety regulations for moderate and large sewage pumping installations.

When the ventilation equipment is of continuous operation type, the minimum capacity shall be 6 turnovers per hour. Ventilation design should provide for the dissipation of the heat generated from the electric motors, especially during hot weather. Wet wells and screen chambers with mechanical equipment shall be provided with positive ventilation equipment to provide 12 turnovers per hour, as this equipment is operated intermittently.

9.5.2.2 SAFETY MEASURES

Railing shall be provided around all manholes and openings where covers may be left open during operation and at other places, where there are differences in levels or where there is danger for people falling. Guards shall be provided on and around all mechanical equipments, where the operator may come in contact with the belt-drives, gears, rotating shafts or other moving parts of the equipment. Staircases shall be provided in preference to ladders particularly for dry well access. Straight staircases shall be provided as against spiral or circular staircases or steps. The steps to be provided in the staircase shall be of the non-slippery type.

Telephone is an essential feature in a pump-house, as it will enable the operator to maintain contact with the main office. In case of injury, fire or equipment-difficulty, telephone will provide facility to obtain proper assistance as rapidly as possible.

Fire-extinguishers, first-aid boxes and other safety devices shall be provided at all pumping stations.

A system of colours for pipes shall minimise the possibility of cross-connections.

To prevent leakages of explosive gases, the wet well should not be directly connected by any opening to the dry well or superstructure.

All electrical equipment and wiring should be properly insulated and grounded and switches and controls should be of non-sparking type. All wiring and devices in hazardous areas should be explosion-proof.

9.5.2.3 OTHER FACILITIES

All sewage and storm-water pumping stations should have potable water-supply, wash-room and toilet facilities and precautions taken to prevent cross connections.

Hoisting equipment shall be provided for handling of equipment and materials which cannot be readily lifted or removed by manual labour. In large pumping stations, gantries of adequate capacities shall be provided to lift the pumps, motors and large piping.

Fencing shall be provided around the pumping station to prevent trespassing.

The station should be landscaped to make it blend with the surroundings and to add to the aesthetic effect, particularly when residential areas are in the near vicinity of the station.

Adequate lighting is essential at the plinth and at all working levels of the pumping station. Glares and shadows shall be avoided in the vicinity of machinery and at floor openings.

9.6 DESIGN CONSIDERATIONS FOR THE DRY AND WET WELLS

9.6.1 Dry Well

The size of the dry well should be adequate for the number of pumps planned of such sizes as will handle the sewage-load at the desired capacity of pumping. Allowance should also be made for future requirements so that additional or larger pumps can be installed.

Provision should be made to facilitate easy removal of pumps and motors for periodic repairs, overhauls or replacements. This shall be done by providing a gantry of suitable capacity and with suitable travelling type chain and pulley blocks. A dewatering pump of the non-clog type shall be provided for the dry well. For easy access to the dry wells of the pumping stations, the dry wells should have a separate entrance and suitable stairways, preferably not less than 90 cm in width shall be provided alongwith 90 cm high railings, wherever required.

9.6.2 Wet Well

The size of the wet well is influenced by the storage capacity to be provided. The storage capacity is required to be designed, especially for all sewage and storm water pumping stations, where automatic controls and variable speed drives are not provided to match pumping rates exactly with inflow-rates to the station. The selection of the proper storage capacity is critical because it affects:

- a) the time for which the liquid will be retained in the pumping station and
- b) the frequency of operation of the pumping equipment.

The shape of the wet well and the detention time provided shall be such that deposition of solids is avoided and sewage does not turn septic. The capacity of the wet well is also concerned with the difference between the highest level of the liquid in the wet well and the minimum level after the depletion by pumping. This should be such that the pump of minimum duty also would run for at least 5 minutes. The capacity of the well is to be so kept that with any combination of inflow and pumping, the cycle of operation for each pump will not be less than 5 minutes and the maximum detention time in the wet well will not exceed 30 minutes of average flow.

In the wet well, baffles should be provided at required places to ensure uniform flow at each pump-suction. The wet well flooring should have benching like a hopper with a minimum slope of 1:1, to avoid deposition of solids. Yet there should be provision for the removal of the accumulated sludge. Suitable provision for overflow should also be made, where feasible, as a protection against flooding, especially in the event of the breakdown of the plant or the failure of the power-supply.

Wherever possible, grit removal ahead of pumping should be adopted to increase the life of the pumps. Coarse screens before the wet wells should have a clear opening of 40 to 50mm between the bars for the manually cleaned type and 25mm for the mechanical type. The screening units shall always be provided in duplicate. The screens shall conform to IS:6280.

While positioning of the pump-intakes or wet-pit pumps in the wet well, the following points need to be taken care of :

- a) Flow approaching the pump-intake should be uniform along the width of the channel
- b) No disturbance which generates kinetic energy should take place in the proximity of the intake
- c) The mean velocity of flow should be low, but not less than 0.7 m/s to prevent deposition of the solids
- d) Benching and corner fillets should be provided to prevent stagnation of the flow
- e) In order to prevent flow-separation, bell-mouths should be provided at the entrance of the suction-pipes. Diameter of the bell-mouth, D should be $1.5 d$ to $1.8 d$, where d is the diameter of the suction-pipe
- f) The clearance of the bell-mouth from the floor should be between $0.5 D$ to $0.75 D$. Unsteady flow in the bell-mouth occurs, if the clearance is less than $0.25D$. If the clearance is too much, the upward flow-component becomes unstable and causes swirling and vortex-formation
- g) The distance of any wall or fillet from the lip of the bell-mouth should be between $0.25 D$ to $0.5 D$. The proximity of the end and the side walls prevents swirling flow and vortex-formation
- h) The width of the sump should be between $2 D$ and $3 D$
- i) The depth of water above the lip of the bell-mouth should be greater than $1.5 D$
- j) Where multiple pumps are used, the spacing between the lips of two adjacent suction bell-mouths should be between 2 to $2.5 D$. With splitters, i.e. separation walls between the suction pipes, their lengths should not be less than $4 D$.

9.7 PUMPS

The selection of pumps is based on many considerations such as the type of pump, the size of pumps, the number of pumps, the capacity or flow-rate of each pump, the range of throttling of each pump, the head of pumping, and others.

9.7.1 Capacity

The capacity of the pumps shall be adequate to meet the peak rate of flow with 50% standby. To obtain the least operating cost, the pumping equipment shall be selected to perform efficiently at all flows, including the peak flow. Two or more pumps are always desirable at sewage pumping stations. The size and the number of units for larger pumping stations shall be so selected that the variations of inflow can be handled by throttling of the delivery valves of the pumps or by varying the speed of the pump, without starting and stopping the pumps too frequently or necessitating excessive storage.

The capacity of a pump is usually stated in terms of Dry Weather Flow (DWF), estimated for the pumping station. The general practice is to provide 3 pumps for a small capacity pumping station comprising 1 pump of 1 DWF, 1 of 2 DWF and third of 3 DWF capacity. For large capacity pumping station, 5 pumps are usually provided, comprising 2 of 1/2 DWF, 2 of 1 DWF and 1 of 3 DWF capacity, including standby.

9.7.2 Size of the Pump

For protection against clogging, the suction and delivery openings of the pumps shall not be less than 100mm and the pumps shall be capable of passing a ball of at least 50mm dia.

9.7.3 Pump-Types

Both the centrifugal type pumps, including the submersible pumps and pneumatic ejectors are used in sewage and storm water stations. The pneumatic ejectors are not recommended, unless a centrifugal pump is impractical as may be in small installations. Screw pumps of the single-screw, progressive cavity, helical rotor type also present themselves as a worthwhile option and are coming into vogue.

Pumps for sewage and storm water pumping are generally of all cast iron construction. If the sewage is corrosive then the stainless steel construction may have to be adopted. Also, where the sewage or storm water would entrain abrasive solids, the pumps in abrasion-resistant material or with elastomer lining may be used.

9.7.4 Centrifugal Pumps

These are generally classified as radial flow, mixed flow and axial flow pumps. The classification is usually based on the specific speed of the pump (n_s), which is obtained from the following formula:-

$$n_s = \frac{3.65n\sqrt{Q}}{H^{0.75}} \quad (9.1)$$

where,

n = speed of the pump in rpm

Q = flow-rate in m^3/s

H = head of the pump in m

The specific speed of the pump is akin to a shape number and forms the basis for the design of the impeller of a centrifugal pump. The shape of the impeller is identifiable by the relative proportions of the inlet size, outlet width and the outside diameter. Broader inlet size and outlet width are logical for larger flows. For higher head-to-speed ratio the impeller would be logically narrower than broader. So, the specific speed is larger and the shape broader proportional to the flow-rate and inversely proportional to the head-to-speed ratio.

The descriptions narrow and tall or broad and short are of course relative, to be indicative of the shape and not the size. A large size impeller can yet be broad and short by its shape. So also a small size impeller can yet be narrow and tall by its shape.

In a narrow and tall impeller, the flow through the impeller will be radial i.e. across a plane perpendicular to the axis of rotation. Hence these are called as radial flow pumps and are pumps of low specific speed, generally between 40 to 150.

In a broad and short impeller, the flow through the impeller will be partly radial and partly axial. Hence, these are called as mixed flow pumps and are pumps of specific speeds in the range from 150 to 350.

In the impellers in the pumps of specific speeds higher than 350, the flow is more or less parallel to the axis of rotation and hence these pumps are called as the axial flow pumps.

In a double-suction pump, the impeller is actually a composite impeller, with two identical flow-passages combined back to back. Each side is practically an independent impeller and each such impeller handles only half the flow. So, the specific speed for such pumps is calculated by taking only half the flow. By this the specific speed of a double-suction pump is only 70% of what the specific would have been with a single-suction design.

Generally pumps of low specific speed can work with more suction-lift than the pumps of higher specific speed. With the pumps of very high specific speed as of the axial flow pumps not only that they would not work with any suction-lift, instead they would need positive suction head or minimum submergence for trouble free working. It is always advisable to avoid suction-lift for any centrifugal pump. In sewage stations the pumps are hence installed either to work submerged in the wet well itself or installed in the dry well at such a level that the impeller will be below the level of the liquid in the wet well. Some typical installations are illustrated in Fig.9.1

The power-characteristics of the centrifugal pumps are also related to the specific speed. The radial flow pumps having low specific speed have such power-characteristics that the required input power to the pump increases as the capacity i.e. the flow-rate of the pump increases. Obviously, in radial flow pumps the power demand is the minimum with zero flow, i.e. with the delivery valve closed. Since the pump should be started with the pump exerting the minimum load on the driver/motor, the radial-flow pumps should be started with the delivery valve closed.

The power-characteristics of the mixed flow pumps are almost flat or with very little gradient. So, the mixed flow pumps can also be started in the manner similar to that for the radial flow pumps.

However, in the case of axial flow pumps, the power needed to be input to the pump is maximum at zero flow. These pumps should hence be started with the delivery valve fully open.

The impellers of centrifugal pumps have vanes which are either open or have shrouds. Open impellers have no shrouds. Semi-open impellers have only a back shroud. Enclosed impellers have both the front and the back shrouds. Axial flow pumps would have only the open impellers. The mixed flow pumps, especially of the higher specific speed would be generally semi-open. But the impellers of radial and mixed flow pumps can be constructed in all the three types. Because the centrifugal pumps used more commonly for clean, clear liquids, enclosed impellers are the most common

construction. The impellers are constructed of the semi-open or open type depending the size of the

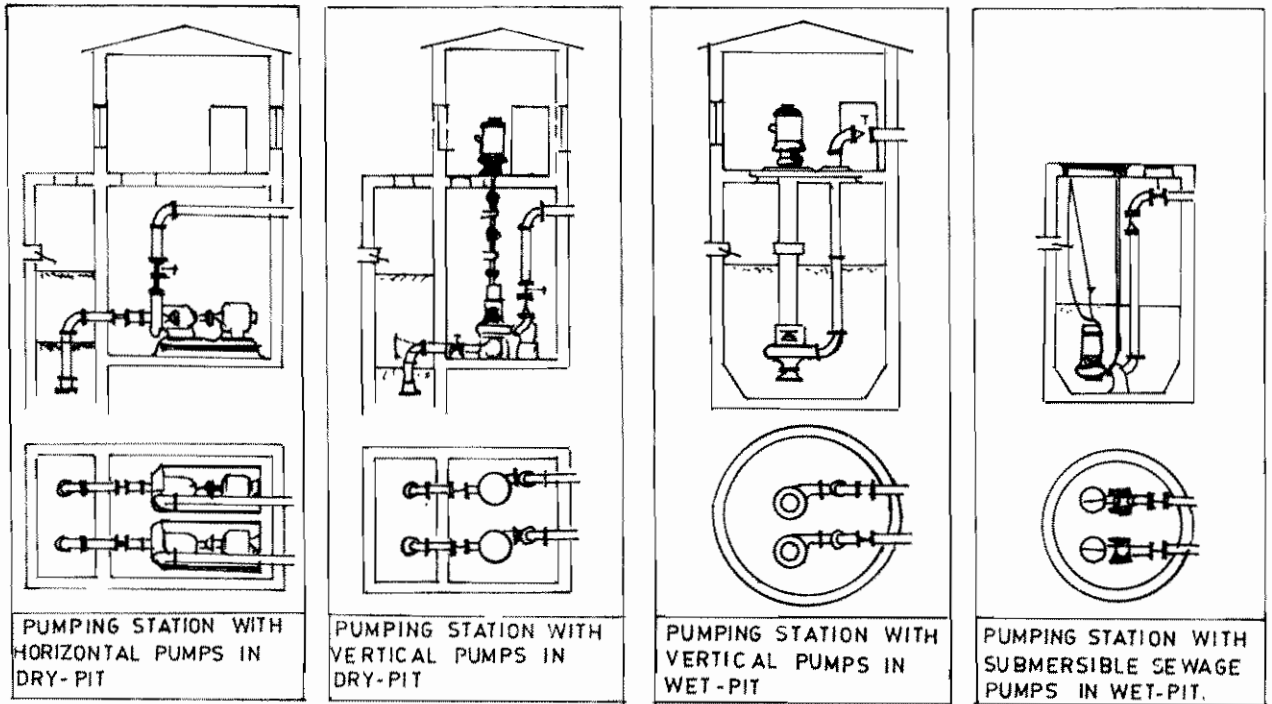

FIG.9.1: TYPICAL DRY-WELL & WET-WELL INSTALLATIONS

solids and the consistency of solids to be handled. For handling large-size solids, the impellers are also designed with fewer vanes. Pumps with fewer vanes in the impeller would however have less efficiency.

In the case of high head pumping, the total head is shared by more than one impeller in the multi-stage pumps. With very high head, for a single-stage pump the specific speed may become less than 40 and in turn so low that even the radial flow design would be too narrow. But by making the head to be shared by more than one impellers, the specific speed for each impeller will be better. On the other hand, high head would be beyond the range of a single-stage, high specific speed mixed flow or axial flow pump. Multi-staging would make the head attainable, as is typically seen in vertical turbine pumps. In multi-stage construction, the flow out of one impeller is carried to the suction of the next impeller, with some conversion of the kinetic energy into pressure-energy in a bowl or a diffuser. In single-stage pumps the energy conversion is achieved in a volute casing around the impeller. For ease of access to the internals the volute casing is often made of the axially split type. This facilitates accessing all the rotating parts for cleaning or repairs, without disturbing the fixation of the pump with the adjoining suction and delivery piping.

9.7.5 Computation of the Total Head of Pumping

The total head of pumping has to be calculated taking note of four factors. Firstly, the difference between the static level of the liquid in the suction sump i.e. the wet well and the highest point on the discharge side makes the potential or static head. Secondly, the rate of flow and the size of the discharge-mouth determine the velocity at the point of discharge and in turn the kinetic or the velocity head. Thirdly, the difference in the pressures on the liquid in the suction sump and at the point of delivery make the pressure head. On the suction side, the liquid in the wet well is open to the atmosphere, but on the delivery side when delivering into a closed conduit sewer, there would be a potential head at the point of delivery, against which the pump will have to deliver. So, the delivery pressure will be higher than atmospheric. The pressure-differential will make the pressure head. Lastly, the pump has to generate as much head as is needed to compensate for the frictional losses across the pipes, valves, bends and all such appurtenances both on the suction and delivery sides. This makes the frictional head.

With the pumps running and if the discharge of the pumps is more than the inflow, the level of the liquid in the wet well would keep falling. By this the potential head component in the total head would keep increasing. Converse will be the case when the inflow is more than the discharge by the pumps.

Throttling of the delivery valve causes a change in the rate of flow and in turn a change in the velocity head which varies in square proportion of the velocity, because the velocity head is computed as $V^2/2g$.

The frictional losses also vary in square proportion of the velocity or flow-rate.

9.7.5.1 SYSTEM HEAD

At the stage of planning, the method of computing the total head of pumping should be to estimate it over a range of flow-rates, for different variations in the static levels and for different options of piping sizes and layouts. This obtains the system head curve, as illustrated in Fig.9.2

With an increase only in the potential head, the new system head curve will be a curve shifted parallel upwards, as shown in Fig.9.3.

For a smaller size of piping, the parabolic portion in the system head curve will be steeper, as shown in Fig.9.4.

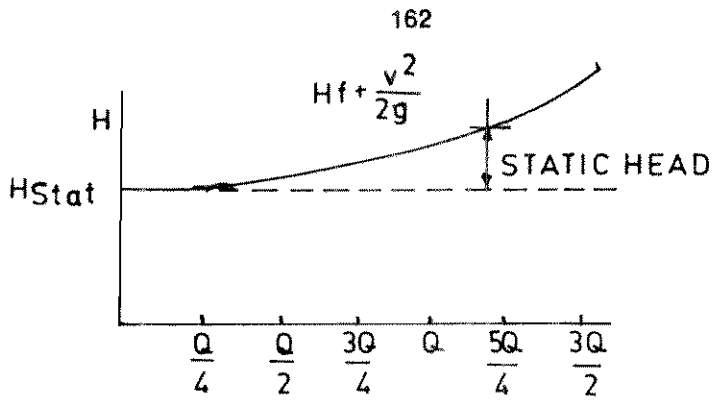

FIG.9.2:SYSTEM-HEAD CURVE FOR A PUMPING SYSTEM

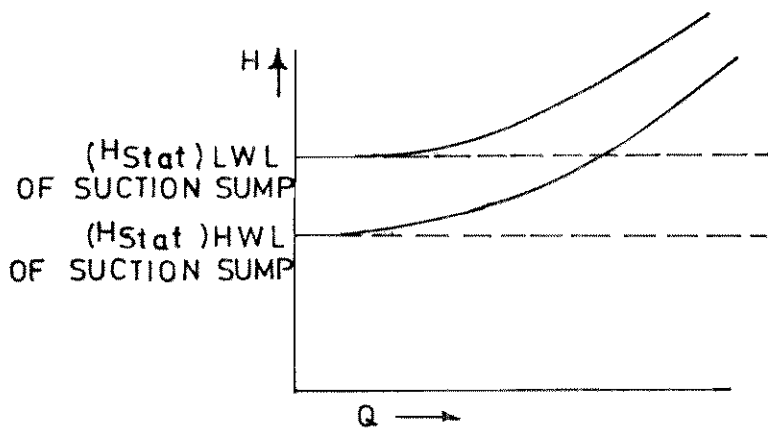

FIG.9.3:SYSTEM-HEAD CURVES FOR LWL & HWL IN SUCTION SUMP

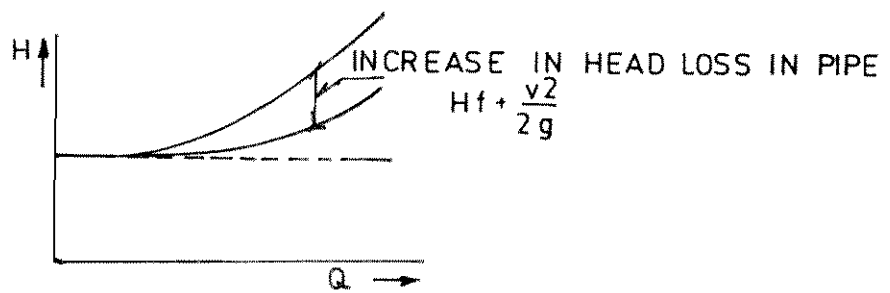

FIG.9.4:SYSTEM-HEAD CURVES WITH CHANGE IN PIPE - SIZES

From the system head curves, one knows what the total head would be for the most average operating condition, which then can be specified as the total head of pumping.

9.7.5.2 OPERATING POINT OF A CENTRIFUGAL PUMP

The Head-Discharge (H vs Q) characteristics of a centrifugal pump is a drooping parabola, with the pump discharge being less when the head is more. When the pump is put into a system, it meets the head as demanded by the system. The system demand is as per the system-head curve. The head met by the pump is as per its H-Q curve. For example, by throttling the delivery valve to close, the system head curve would become a steeper parabola and would intersect the H-Q curve of the pump at a point of higher head and less discharge, such becoming the new operating point of the pump. This is illustrated in Fig.9.5.

9.7.5.3 PARALLEL OPERATION

When more than one pump would be discharging into a common closed conduit or header, the performance characteristics of the pumps suffer mutual influences. Pumps discharging into a common closed header/conduit are said to be running in parallel. The flow obtained in the header is what is contributed by all the running pumps together. The combined characteristics of pumps running in parallel is obtained by reading against different heads, the values of the Q obtainable from the individual pumps and plotting the addition of the Q-values against respective heads, as illustrated in Fig.9.6. The operating point of parallel operation is the point of intersection of the combined H-Q curve with the system head curve. Because the point of intersection on the combined characteristics is at a head higher than that at the point of intersection on the H-Q curve of a single pump, the discharge at the operating point of intersection on the H-Q curve of a single pump. From this it is clear that two identical pumps put into parallel operation will give discharge less than the double the discharge of only one pump operating. That means that to double the discharge capacity of pumping, it is not adequate to commission two pumps in parallel operation. One must study what combination of pumps of different H-Q characteristics can give such combined characteristics as to have an intersection on the combined characteristics at the desired double discharge.

As seen from Fig.9.6, if there are two identical pumps running in parallel, individual pump would be contributing a discharge Q_p . If one of the pumps would trip the system would have only one pump running and giving a discharge Q_1 , which is more than Q_p . At higher discharge, the pump would draw more power, which should not overload its motor. While putting the pumps into parallel operation, it is sound logic hence to provide that the discharge Q_p in parallel operation would be somewhat to the left of the discharge at the best efficiency-point (b.e.p.) of the pump, such that in the event of tripping of any other pump/s, the higher discharge such as Q_1 of the running pump will only be nearer to its b.e.p.

9.7.5.4 STABLE CHARACTERISTICS

It is possible that on the H-Q curve of a centrifugal pump, the shut-off head will not be the maximum head, as shown in Fig.9.7.

Such H-Q curve is called unstable, because at heads higher than the shut-off head, the discharge of the pump keeps hunting between two values, causing the pump's performance to be unstable. Such instability is prone to cause the pump to even suffer vibrations. This becomes more hazardous in parallel operation, because the hunting of flow of the unstable pump causes the other pumps also to experience continuous change in their share and in turn hunting, instability and vibrations. Pumps to be put into parallel operation should hence be only of stable H-Q curve or care should be taken that the system head will definitely be safely less than the shut-off head of the pump with unstable curve

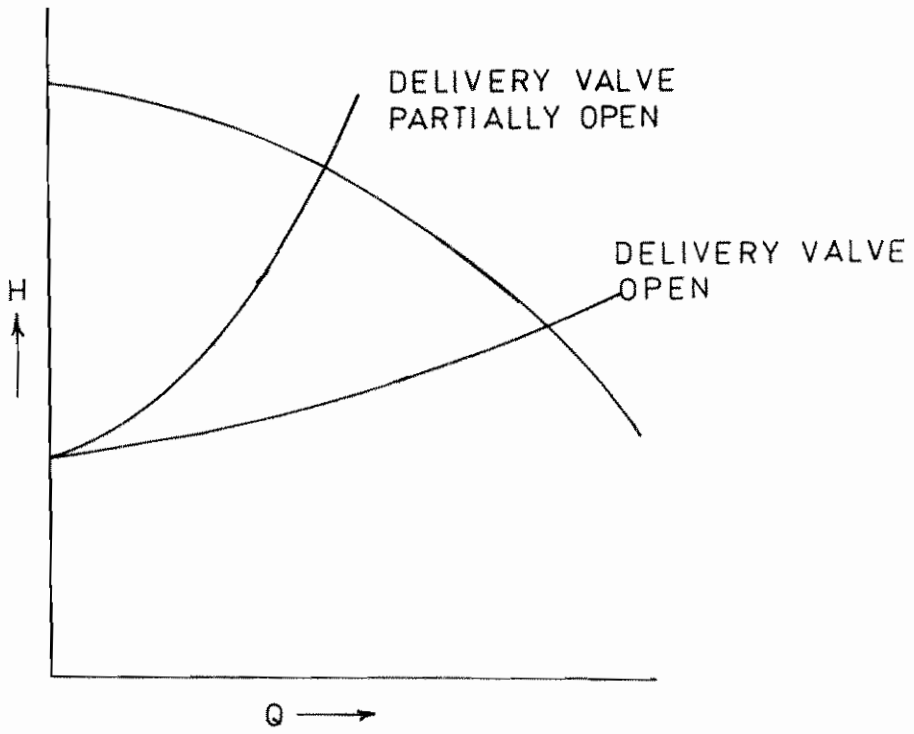

FIG.9.5: CHANGE IN OPERATING POINT BY OPERATION OF DELIVERY VALVE

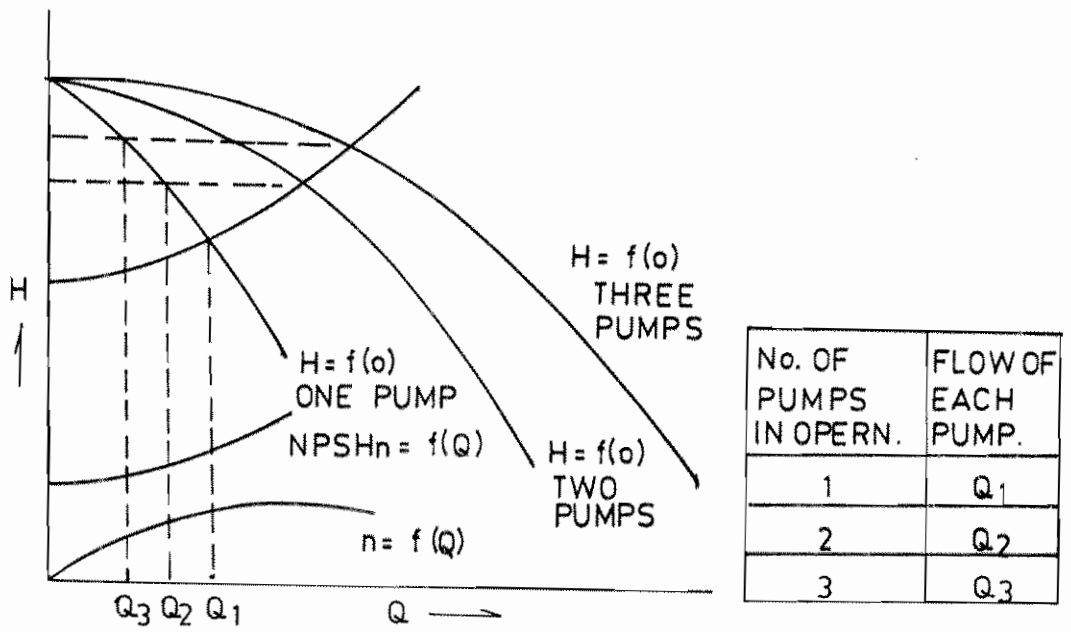

FIG.9.6: OPERATION OF PUMPS IN PARALLEL

9.7.5.5 CAVITATION

The flow must reach the eye of the impeller with such absolute pressure-head, that it will be higher than the vapour-pressure and the nett positive suction head required (NPSH_r) by the pump. The absolute pressure-head of the flow, as it reaches the eye of the impeller can be found by deducting from the pressure on the liquid in the suction sump, which is atmospheric in the case of an open sump such as the wet well, firstly, the static head between the liquid level in the suction sump, which is atmospheric in the case of an open sump such as the wet well, firstly, the static head between the liquid level in the suction sump and the centre-line of the pump, if the pump's centre line is above the liquid-level, i.e. if there is a suction-lift. If the centre-line of the pump is below the liquid level, i.e. if the suction is flooded, the static head will have to be added and not deducted. Next, the velocity-head, appropriate to the suction-size will have to be deducted. Also, the frictional losses upto the eye of the impeller will also have to be deducted. Even if the flow has a positive absolute pressure, after all the deductions, while reaching the eye of the impeller, the flow suffers from shocks, twists, turns and turbulances at the eye of the impeller. This tax on the energy in the flow is called as the nett positive suction head required (NPSH_r) of the pump. So, the positive absolute pressure of the flow, as it reaches the eye of the impeller should be more than the vapour pressure (V_v) even after providing for NPSH_r.

This means:

$$(\text{Pressure head at the eye of the impeller}) > (\text{NPSH}_r + V_v)$$

$$\text{i.e.} (\text{Pressure head at the eye of the impeller} - V_v) > (\text{NPSH}_r)$$

The value in the parenthesis now on the left is termed as the NPSH_a, i.e. Nett Positive Suction Head available. NPSH_a can hence be derived as follows:-

$$\text{NPSH}_a = \text{Pressure on liquid in the suction sump} \pm \text{Static head between the liquid level in the suction sump and the centre line of the pump} - \text{velocity head} - \text{frictional losses upto the eye of the impeller} - \text{vapour pressure}$$

If the NPSH_a be not greater than NPSH_r, vapour bubbles get formed, which while travelling along the flow, being compressible receive energy from the impeller which builds up the pressure inside them and the resultant compression reduces their volume culminating in the collapse of the bubbles with sudden release of the energy. This causes impact and vibrations. All this phenomenon is called cavitation. Cavitation can cause very serious damages. The simple clue to avoid cavitation is to ensure that NPSH_a will be more than NPSH_r. The formula given above for NPSH_a, suggests many possibilities of keeping NPSH_a as high as possible.

9.7.6 Progressive Cavity, Helical Rotor Pumps

These are positive displacement type pumps. Their H-Q characteristics is hence virtually a vertical straight line, parallel to the y-axis for the head of the pump. This means that the pumps would develop head upto the point of delivery, if it is open. If any positive displacement is worked with its delivery closed, the pump will keep developing very high pressures, limiting only by the capacity of the drive motor. To safeguard against such high pressures being developed, all positive displacement pumps, which have to deliver into a system with a dead end or into a system, which may get blocked and become a dead-ended system, have to be provided with a pressure-relief safety valve.

The progressive cavity helical rotor pumps have a helical rotor and a rubber stator. There are no valves. The pumps can handle liquids with solids. The discharge of the pumps can be varied by varying the speed of the pump. The pumps have a self-priming capability by virtue of being of the positive-displacement type. However, the rubber stator needs to be wetted before starting up the pump. Alternatively, the pump-end can be submerged into the liquid to be pumped, keeping the motor on the surface. The rubber stator is the most wear-prone component of the pump.

9.7.7 Installation of Pumps

The procedure of installation depends upon whether the pump is to be mounted horizontally or vertically. Most pumps to be mounted horizontally are supplied by the manufacturers as a wholesome, fully assembled unit. However, pumps to be mounted vertically are supplied as sub-assembled. For the installation of these pumps, the proper sequences of assembly has to be clearly understood from the manufacturers' drawings.

The installation of a pump should proceed through five stages in the following order:-

- Preparing the foundation and locating the foundation bolts
- Locating the pump on the foundation bolts, however resting on levelling wedges, which permit not only easy levelling but also space for filling in the grout later on
- Levelling
- Grouting
- Alignment

The foundation should be sufficiently substantial to absorb vibrations and to form a permanent, rigid support for the base plate. A typical foundation is illustrated in Fig.9.8.

The capacity of the soil or of the supporting structure should be adequate to withstand the entire load of the foundation and the dynamic load of the machinery. As mentioned in clauses 6.2.2 and 6.2.3 of IS:2974 (Part-IV) 1979, the total load for the pumpset and foundation should include the following:-

- a) constructional loads
- b) three times the total weight of the pump
- c) two times the total weight of the motor
- d) weight of the water in the column pipe
- e) half of the weight of the unsupported pipe, connected to the pump-flanges.

If the pumps are mounted on steel structures, the location of the pump should be as nearest as possible to the main members (i.e. beams or walls). The sections for structural should have allowance for corrosion also.

A curb-ring or a sole-plate with machined top should be used as a bearing surface for the support flange of a vertical wet-pit pumps. The mounting face should be machined, because the curb-ring or sole-plate is used to align the pump. Fig.9.9 shows typical arrangement with curb-ring and with sole-plate. Pumps kept in storage for a long time should be thoroughly cleaned before installation.

Submersible pumps with wet type motors should be filled with water and the opening should be properly plugged after filling the water.

Alignment of the pumpsets should be checked, even if they are received aligned by the manufacturer. The alignment should be proper both for parallelism (by filler guage) and for co-axiality (by straight edge or by dial gauge). During all alignment-checks, both the shafts should be pressed hard, over to one side, while taking readings. Alignment should be also checked after fastening the piping and thereafter, periodically during operation.

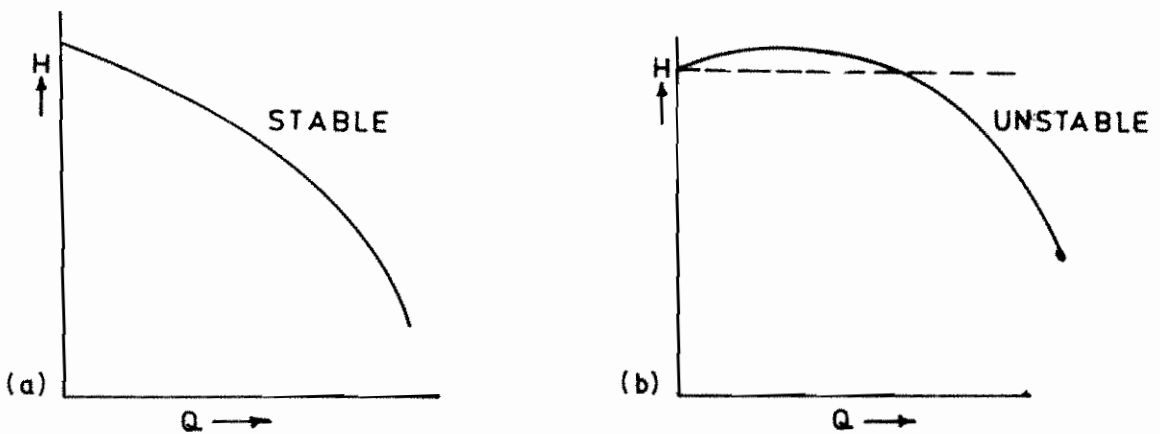

FIG.9.7: STABLE & UNSTABLE CHARACTERISTICS OF CENTRIFUGAL PUMPS

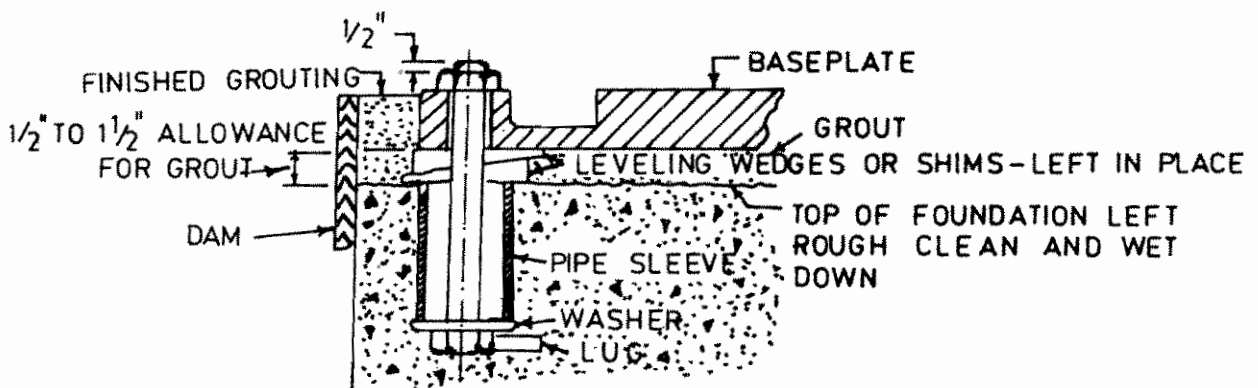

FIG.9.8: TYPICAL FOUNDATION FOR A PUMP

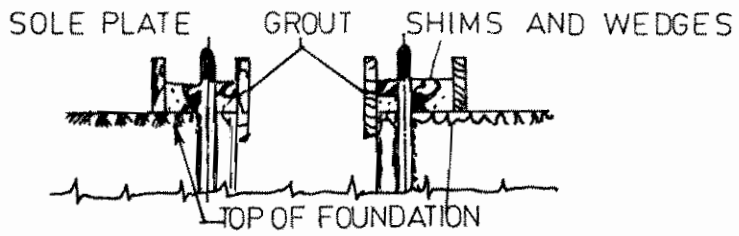
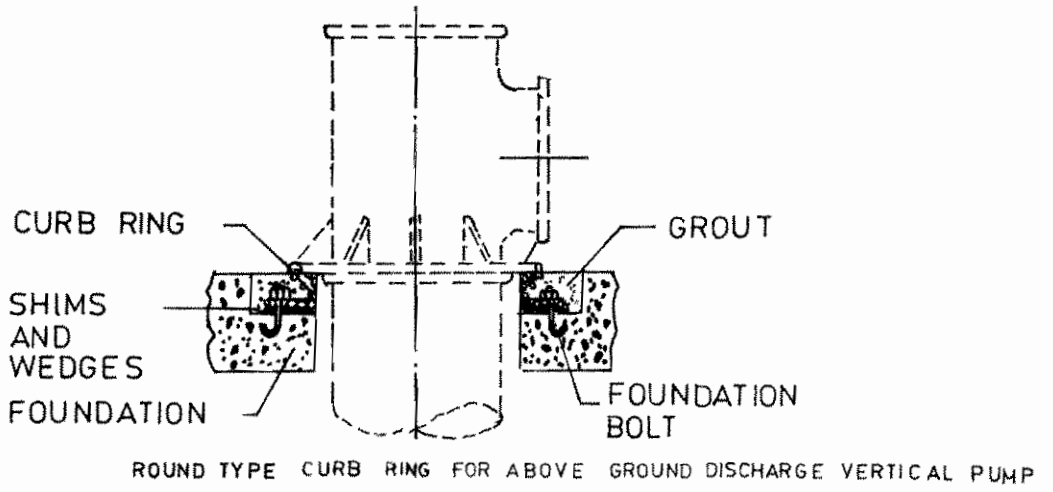

FIG.9.9: FOUNDATION FOR VERTICAL PUMPS

9.7.8 Operation of the Pumps

Dry running of the pumps should be avoided. Centrifugal pumps should be started only after priming.

Helical rotor pumps, although they are self-priming, being of the positive displacement type, need the rubber-stator to be wetted before starting.

It should be ensured that the direction of the motor agrees with the arrow on the pump.

Pumps should be operated only within the recommended range on the H-Q characteristics of the pump.

Operation near to the shut-off head of the pump should be totally avoided, as recirculation within the pump will cause overheating.

Whether a pump should be started with the delivery valve open or closed has to be decided by studying their power-characteristics. Pumps of low and medium specific speeds draw more power as the flow increases. So to minimise the load on the motor at the time of starting, such pumps are started with the delivery valve closed. Conversely, pumps of high specific speed drawn more power at shut-off. These pumps should hence be started with the delivery valve open.

While stopping, the position of the delivery valve should be as at the time of starting.

When pumps are to operate in parallel, the pumps should be started and stopped with time-lag between two pumps. The time-lag should be adequate to let the pressure-gauge stabilise.

The delivery valve should be operated gradually, to avoid surges.

When pumps are to operate in series, they should be started and stopped sequentially, but with minimum time-lag as possible. Any pump, next in sequence should be started immediately after the delivery valve of the previous pump is even partly opened.

Due care should be taken to keep the air-vent of the pump, next in sequence, open, before starting that pump.

The stuffing box should let a drip of leakage to ensure that no air is passing into the pump and that the packing is getting adequate water for cooling and lubrication.

When the stuffing box is grease-sealed, adequate refill of the grease should be maintained.

The running of the duty-pumps and of the standbys should be so scheduled that all pumps are in ready-to-run condition.

9.7.9 Maintenance of Pumps

The maintenance schedule should enlist items to be attended to at different periods, such as daily, semi-annually, annually, and others

9.7.9.1 DAILY OBSERVATIONS

- i) Leakage through packings
- ii) Bearing temperature
- iii) Whether any undue noise or vibration
- iv) Pressure, voltage and current readings.

9.7.9.2 SEMI-ANNUAL

- i) Free movement of the gland of the stuffing box
- ii) Cleaning and oiling of the gland-bolts
- iii) Inspection of packing and repacking, if necessary
- iv) Alignment of the pump and the drive
- v) Cleaning of oil-lubricated bearings and replenishing fresh oil. If bearings are grease-lubricated, the condition of the grease should be checked and replaced to correct quantity, if necessary.

An anti-friction bearing should have its housing so packed with grease, that the void spaces in the bearings and the housing be 1/2 to 2/3 filled with grease. A fully packed housing will cause the bearing to overheat and will result in reduced life of the bearing.

9.7.9.3 ANNUAL INSPECTION

- i) Cleaning and examination of all bearings for flaws developed, if any
- ii) Examination of shaft-sleeves for wear or scour
- iii) Checking Clearances

Clearances at the wearing rings should be within the limits recommended by the manufacturer. Excessive clearances mean a drop in the efficiency of the pump. If the wear is on only one side, it means mis-alignment. Not only that the mis-alignment should be set right, but also the causes for the disturbance of the alignment should be investigated and the clearances have to be redeemed to the values recommended by the manufacturers. If the clearance on wear is seen to be 0.2 or 0.25mm more than the original clearance, the wearing ring should be renewed or replaced to get original clearance.

- iv) Impeller-hubs and vane-tips should be examined for any pitting or erosion
- v) End-play of the bearings should be checked
- vi) All instruments and flow-meters should be re-calibrated
- vii) Pump should be tested to determine, whether proper performance is being obtained
- viii) In the case of vertical turbine pumps, the inspection can be bi-annual. Annual inspection is not advisable, because it involves disturbing the alignment and clearances.

9.7.9.4 FACILITIES FOR MAINTENANCE AND REPAIRS

- i) Consumable and Lubricants

Adequate stock of such items as gland packings, belts, lubricating oils, greases should be maintained

ii) Replacement spares

To avoid downtime, a stock of fast-moving spares should be maintained. A set of recommended spares, for two years of trouble-free operation should be ordered along with the pump

iii) Repair Work-shop

The repair work-shop should be equipped with

- a) tools such as bearing-pullers, clamps, pipe-wrenches, and others
- b) general-purpose machinery such as welding set grinder, blower, drilling machine, and others.

9.7.10 Trouble-Shooting

Guidelines for diagnosing the causes of troubles likely to arise during the operation of pumps are detailed in the paragraphs 9.7.10.1, 9.7.10.2 and 9.7.10.3. Corrective action to eliminate the causes would be the appropriate remedial measures.

9.7.10.1 CHECK CHART FOR CENTRIFUGAL PUMP TROUBLES

a) Symptom 1: No flow from the pump

- | | |
|---------------------------|-----------------------------------|
| 1. Pump not primed | 2. Priming inadequate or improper |
| 3. Suction lift too high | 4. Air pocket in suction |
| 5. Suction inlet open | 6. Speed too low |
| 7. Reverse rotation | 8. System Head is too high |
| 9. Discharge line clogged | 10. Improper parallel operation |

b) Symptom 2: Less flow from the pump

- | | |
|---------------------------------|-------------------------------|
| 1. Priming inadequate/improper | 2. Suction lift too high |
| 3. Inadequate margin on NPSHr | 4. Excess air/gas in liquid |
| 5. Air pocket in suction line | 6. Air leaks into suction |
| 7. Air through stuffing box | 8. Footvalve too small |
| 9. Footvalve clogged | 10. Suction inlet open |
| 11. Speed too low | 12. System Head is high |
| 13. Improper parallel operation | 14. Ingress of foreign matter |
| 15. Wearing rings worn | 16. Impeller damaged |
| 17. Casing gasket defective | |

c) Symptom 3: Less pressure

- | | |
|--------------------------------|----------------------------|
| 1. Speed too low | 2. Reverse rotation |
| 3. System Head too high | 4. Viscosity different |
| 5. Improper parallel operation | 6. Wearing rings worn |
| 7. Impeller damaged | 8. Casing gasket defective |

d) Symptom 4: Loss of prime after starting

- | | |
|---|--------------------------------|
| 1. Priming inadequate/
improper | 2. Suction lift too high |
| 3. Excess air/gas in liquid
suction line | 4. Air pocket in suction line |
| 5. Air leaks into suction | 6. Air through stuffing box |
| 7. Suction inlet open | 8. Block in lantern connection |
| 9. Lantern out of position | |

e) Symptom 5: Excess Power

- | | |
|---------------------------------|-----------------------------|
| 1. Speed too high | 2. Reverse rotation |
| 3. System Head is high | 4. System Head is low |
| 5. Denser liquid | 6. Viscosity different |
| 7. Ingress of foreign
matter | 8. Misalignment |
| 9. Shaft bent | 10. Rubbing in running |
| 11. Wearing rings worn | 12. Poor fitting of packing |
| 13. Incorrect packing | 14. Gland too tight |

f) Symptom 6: Leakage through packing

- | | |
|----------------------------|------------------------------|
| 1. Lantern out of position | 2. Misalignment |
| 3. Shaft bent | 4. Scouring on shaft |
| 5. Poor fitting of packing | 6. Incorrect packing |
| 7. Shaft runs eccentric | 8. Rotor out of balance |
| 9. Poor cooling to packing | 10. Packing spills into pump |
| 11. Dirt/grit at lantern | |

g) Symptom 7: Packing life is less

- | | |
|--------------------------------|-----------------------------|
| 1. Block in lantern connection | 2. Lantern out of position |
| 3. Misalignment | 4. Shaft bent |
| 5. Bearings worn | 6. Scouring on shaft |
| 7. Poor fitting of packing | 8. Incorrect packing |
| 9. Shaft runs eccentric | 10. Rotor out of balance |
| 11. Gland too tight | 12. Poor cooling to packing |
| 13. Packing spills into pump | 14. Dirt/grit at lantern |

h) Symptom 8: Vibration or noise

- | | |
|--------------------------------|---------------------------------|
| 1. Priming inadequate/improper | 2. Suction lift too high |
| 3. Inadequate margin on NPSHr | 4. Footvalve too small |
| 5. Footvalve clogged | 6. Suction inlet open |
| 7. Operation at low Q | 8. Ingress of foreign matter |
| 9. Misalignment | 10. Slack foundation |
| 11. Shaft bent | 12. Rubbing in running |
| 13. Bearings worn | 14. Impeller damaged |
| 15. Shaft runs eccentric | 16. Rotor out of balance |
| 17. Axial thrust not balanced | 18. Over-lubrication |
| 19. Poor lubrication | 20. Wrong fitting of bearings |
| 21. Dirt in bearings | 22. Rusting or water in bearing |
| 23. Condensation at bearing | |

i) Symptom 9: Fast wear of bearings

- | | |
|------------------------------|---|
| 1. Misalignment | 2. Shaft bent |
| 3. Rubbing in running | 4. Bearings worn |
| 5. Shaft runs eccentric | 6. Rotor out of Balance |
| 7. Axial thrust not balanced | 8. Over-lubrication |
| 9. Poor lubrication | 10. Wrong fitting of bearings |
| 11. Dirt in bearings | 12. Rusting or water in bearings |

13. Condensation at bearing
- j) Symptom 10: Overheat or seizure
- | | |
|-------------------------------|--------------------------------|
| 1. Pump not primed | 2. Inadequate margin on NPSHr |
| 3. Operation at low Q | 4. Improper parallel operation |
| 5. Misalignment | 6. Rubbing in running |
| 7. Bearings worn | 8. Shaft runs eccentric |
| 9. Rotor out of balance | 10. Gland too tight |
| 11. Axial thrust not balanced | |

9.7.10.2 CHECK-CHART FOR RECIPROCATING PUMP TROUBLES

- a) Symptom 1: Liquid end noise
- | | |
|----------------------------------|-----------------------------|
| 1. Insufficient suction pressure | 2. Partly loosing prime |
| 3. Shocks in system | 4. Improper piping |
| 5. Air in liquid | 6. Over-pressure/Over-speed |
| 7. Broken or worn valve | 8. Worn packing |
| 9. Obstruction at valve | |
- b) Symptom 2: Power end noise
- | | |
|------------------------|------------------|
| 1. Main bearings loose | 2. Worn bearings |
| 3. Low oil level | 4. Plunger loose |
- c) Symptom 3: Overheating of power end
- | | |
|-----------------------------|---------------------------|
| 1. Over-pressure/over-speed | 2. Low oil level |
| 3. Main bearings tight | 4. Inadequate ventilation |
| 5. Belts too tight | 6. Driver misaligned |
- d) Symptom 4: Water in crank-case
- | | |
|-----------------|--|
| 1. Condensation | |
|-----------------|--|
- e) Symptom 5: Leakage from crank-case
- | | |
|---------------|--|
| 1. Worn seals | |
|---------------|--|

- f) Symptom 6: Fast wear of packing or plunger
- | | |
|------------------------------------|----------------------|
| 1. Dirty liquid | 2. Dirty environment |
| 3. Foundation not rigid, not level | 4. Loose packing |
- g) Symptom 7: Pitting at valve-seat
- | | |
|---------------|-----------------|
| 1. Cavitation | 2. Dirty liquid |
| 3. Corrosion | |
- h) Symptom 8: Valves hang up
- | | |
|------------------|------------------------|
| 1. Valve binding | 2. Broken valve spring |
|------------------|------------------------|
- i) Symptom 9: Leakage at cylinder valve
- | | |
|-----------------------------|------------------------|
| 1. Over-pressure/over-speed | 2. Water hammer |
| 3. Loose cylinder plug | 4. Damaged O-ring seal |
- j) Symptom 10: Loss of prime
- | | |
|----------------------------------|-----------------------------|
| 1. Insufficient suction pressure | 2. Lift too high |
| 3. Leaking suction | 4. Required accel head high |

9.7.10.3 CHECK-CHART FOR ROTARY PUMP TROUBLES

- a) Symptom 1: No flow
- | | |
|--------------------------|---------------------------|
| 1. Priming improper | 2. Suction partly open |
| 3. Strainer clogged | 4. Leaky footvalve |
| 5. Suction lift too high | 6. Air leaks into suction |
| 7. Reverse rotation | 8. Low speed |
| 9. Pump worn | |
- b) Symptom 2: Less flow
- | | |
|---------------------------|-----------------------------|
| 1. Air leaks into suction | 2. Inadequate liquid supply |
| 3. Excessive pressure | 4. Bent drive shaft |
| 5. Coupling off-balance | 6. Relief valve chatters |

- c) Symptom 3: Pump runs noisy
- | | |
|-----------------------|------------------------|
| 1. Excessive pressure | 2. Grit/Dirt in liquid |
| 3. Pumps runs dry | 4. Strain from piping |
| 5. Corrosion | |
- d) Symptom 4: Rapid wear
- | | |
|---------------------------|-----------------------------|
| 1. Strainer clogged | 2. Suction lift too high |
| 3. Air leaks into suction | 4. Suction line under-sized |
| 5. Low speed | 6. Pump worn |
| 7. Air leak at packing | 8. Relief valve semi-open |
- e) Symptom 5: Excess power
- | | |
|-----------------------------|-----------------------------|
| 1. Priming improper | 2. Suction partly open |
| 3. Air leaks into suction | 4. Suction line under-sized |
| 5. Inadequate liquid supply | |
- f) Symptom 6: Loss of prime
- | | |
|----------------------|--------------------------|
| 1. Viscosity higher | 2. Blockage in discharge |
| 3. Bent drive shaft | 4. Strain from piping |
| 5. Packing too tight | |

9.8 PRIME MOVERS

The pumps used in sewage and storm water pumping stations are driven either by engines or by electric motors. The electric motors are mainly of three types viz induction (A.C.) motors, synchronous (A.C.) motors, D.C. motors. Amongst these, induction motors are the most common. Synchronous motors merit consideration when large-hp, low speed motors are required. D.C. motors are used occasionally, especially for the speed variation being electrically itself possible.

9.8.1 Selection Criteria

Type of motor has to be selected considering various criteria such as the constructional features desired, environmental conditions, type of duty, simplicity and ruggedness of construction, endurance life, working and capital costs and others

9.8.2 Constructional Features of Induction Motors

Squirrel cage motors are most commonly used. Normally the starting torque requirement of centrifugal pumps is quite low and squirrel cage motors are therefore suitable. Slip ring or wound rotor motors are to be used where required starting torque is high as in positive displacement pumps or for centrifugal pumps handling sludge. The slip ring motors are also used when the starting current has to be very low, such as 1.25 times the full load current, such regulatory limits being specified by the Power Supply Authorities.

9.8.3 Method of Starting

Squirrel cage motors when started direct-on-line (with DOL starters) draw starting current about 6 times the full load (FL) current. If the starting current has to be within the regulatory limits specified by the Power Supply Authorities, the squirrel cage motors should be provided with the star delta starter or auto transformer starter.

9.8.4 Voltage Ratings

Table 9.1 would give general guidance on the standard voltages and corresponding range of motor ratings.

**TABLE 9.1
SELECTION OF MOTORS BASED ON SUPPLY VOLTAGES**

Supply	Voltage	Range of Motor rating in KW	
		Min.	Max.
1 ϕ a.c.	230 V	0.3	2.5
3 ϕ a.c.	415 V	-	250
	3.3 KV	225	750
	6.6 KV	400	-
	11 KV	600	-
d.c.	230 V	-	150

N.B. When no minimum is given, very small motors are feasible.

When no maximum is given very large motors are feasible.

For motors of ratings 225 KW and above, where HT voltages of 3.3 KV, 6.6 KV and 11 KV can be chosen, the choice should be made by working out relative economics of investment and running costs, taking into consideration costs of transformer, motor, switchgear, cables and others

9.8.5 Types of Enclosure

The type of enclosure provides protection to the internals of the construction of a motor. The type of protection and the type of environment are detailed in Table 9.2

**TABLE 9.2
PROTECTIVE ENCLOSURES AND TYPES OF ENVIRONMENT**

Type	Environment type	Description of Environment
Screen-protected drip proof, SPDP		Indoor, clean (dust-free) environment
Total enclosed	IP 44	Indoor, dust-prone areas
fan cooled, TEFC	IP 54	Normal Outdoor
	IP.55	Outdoor at places of heavy rainfall.

9.8.6 Class of Duty

All motors should be suitable for continuous duty i.e. class S1 as specified in IS:325. Additionally, it is recommended that motors should be suitable for minimum 3 equally spaced starts per hour. The motor should also be suitable for at least one hot restart.

9.8.7 Insulation

Class B insulation is generally satisfactory, since it permits temperature rise upto 80° C. At cool places having maximum ambient, of 30° C or less, motors with Class E insulation can also be considered.

At hot places having maximum ambient above 40° C motors with Class F insulation should be considered.

9.8.8 Margin in Brake Kilowatts (BkW)

Motors are rated as per the output shaft horsepower (Brake kilowatts, BkW). The motor rating should be selected as to provide margins over the BkW required by the pump at its operating point. The margins recommended are compiled in Table 9.3.

TABLE 9.3
MARGINS FOR MOTOR-RATINGS

Required BkW of Pump	Multiplying factor to decide motor-rating
Upto 1.5	1.5
1.5 to 3.7	1.4
3.7 to 7.5	1.3
7.5 to 15	1.2
15 to 75	1.15
Above 75	1.1

9.9 ELECTRICAL EQUIPMENT

The electrical equipment selected shall be adequate, reliable and safe. The adequacy is determined by the continuous current required for the station-load and the available short-circuit characteristics of the power supply. The reliability depends upon the capability of the electrical system to deliver power, when and where it is required, under normal as well as abnormal conditions. Safety involves the protection to the plant personnel and also the safeguarding of the equipment under all conditions of operation and maintenance. None of these three aspects shall be sacrificed for the sake of initial economy. The electrical system shall be designed with such flexibility as to permit one or more components to be taken out of service at any time without interrupting the continuous operation of the station. A proper selection of voltages in the electrical system is one of the most important decisions that will affect the overall system-characteristics and the plant-performance. The station bus bar voltage shall be at the level that is most suitable for the pump-motors, which constitute the major part of the load.

9.9.1 Switch Gear

The functions of a switch gear in a distribution system include normal and fault-switching operations and equipment protection. Motor-starting function may sometimes be vested in the switch gear, but only when the required frequency of starting and stopping is low or in applications, where the motors are of such magnitude that no other equipment is suitable.

Normally outdoor substations are provided. However on considerations of public safety and for protection from exposure to environmental pollution, the substations may be indoors. Following are the essential features of a transformer substation.

1. Lightning arresters
2. Ground operated disconnectors (GOD) are provided in outdoor substation. In indoor substation, circuit breakers are provided. In case of outdoor substations of capacities 1000 KVA and above, circuit breakers should be provided in addition to GOD
3. Drop out fuses for small outdoor substations
4. Overhead bus bars and insulators
5. Transformer
6. Current transformer and potential transformer for power measurement
7. Current transformer and potential transformers for protection in substations of capacity above 1000 KVA
8. Fencing
9. Earthing.

Earthing should be very comprehensive, covering every item in the substation, and in accordance with IS:3043.

Duplicate transformer may be provided, where installation so demands.

9.9.2 Starters

Starters are of different types, viz. DOL, Star-Delta, auto-transformer and stator-rotor. Of these, the last one is used with slip-ring motors. The other three are used with squirrel-cage motors. General guidelines regarding the use of starters for squirrel cage motors are given in Table 9.4.

TABLE 9.4
GUIDELINES FOR STARTERS FOR SQUIRREL-CAGE MOTORS

Type of Starter	Percentage of Voltage Reduction	Starting Current	Ratio of starting torque to locked rotor torques %
DOL	Nil	6 x FLC	100
Star-delta	58%	2 x FLC	33
Auto-Transformer	tap 50%	1.68 x FLC	25
	tap 65%	2.7 x FLC	42
	tap 80%	4 x FLC	64

FLC = Full Load Current.

Note: As per torque speed characteristics of the motor, the torque of the motor at the chosen percentage of reduced voltage should be adequate to accelerate the pump to the full speed.

9.9.3 Capacitors

For improvement of power factor, appropriate capacitors should be provided. Capacitors may be located in the control panel or separately.

9.9.4 Cables

Table 9.5 gives guidance on the type of cable to be used for different voltages.

TABLE 9.5
TYPES OF CABLES FOR DIFFERENT VOLTAGES

Sr.No.	Range of Voltage	Type of Cable to be used	IS Ref.
1.	1 - 230 V or 3 - 415 V	PVC insulated, PVC Sheathed	IS 1554
2.	Upto 6.6 KV	PVC insulated, PVC Sheathed	IS 1554
		Paper insulated, lead Sheathed	IS 692
		XLPE, Cross Linked, Polyethylene insulated, PVC sheathed	
3.	11 KV	Paper insulated, lead sheathed	IS 692

The size of the cable should be so selected that the total drop in voltage, when calculated as the product of current and the resistance of the cable shall not exceed 3%. Values of the resistance of the cable are available from the cable-manufacturers.

In selecting the size of the cable the following points should be considered.

1. The current carrying capacity should be appropriate for the lowest voltage, the lowest power factor and the worst condition of installation i.e. duct-condition
2. The cable should also be suitable for carrying the short circuit current for the duration of the fault. The duration of the fault should preferably be restricted to 0.1 s by proper relay setting.

Appropriate rating factors should be applied when cables are laid in group (parallel) and/or laid below ground.

For laying cables, suitable trenches or racks should be provided.

9.10 CONTROLS

Controls should be simple, direct and reliable. Large pumping systems may have controls that automatically start and stop the pump-units and associated valves and auxiliaries. A proper hand-operated selector switch may also be provided to avoid over-working of any one pumping unit. Liquid level controls generally employ floats, ceramic floats being preferred to metal floats as the latter are

affected by the chemical action of the sewage. All floats are subject to accumulation of grease and scum.

The various functions which a control-panel has to serve and the corresponding provisions to be made in the panel are detailed below:

1. For receiving the supply
Circuit breaker or switch and fuse units
2. For distribution
Bus bar, Switch fuse units, circuit breakers
3. For controls
Starters; level-controls, if needed; Time-delay relays
4. As protections
Under-voltage relay, Over-current relay, Hot-fault relay, Single phasing preventer
5. For indications and readings
Phase indicating lamps, voltmeters, Ammeters, Frequency meter, power factor meter, temperature scanners, Indicators for state of relays, indications for levels, indications of valve positions, if valves are power actuated.

The scope and extent of provisions to be made on the panel would depend upon the size and importance of the sewage and storm-water pumping station.

The regulations, as per I.E. Rules, in respect of space to be provided around the panel are detailed as follows.

9.11 MAINTENANCE AND REPAIRS OF ELECTRICAL EQUIPMENT

9.11.1 Facilities for Maintenance and Repairs

Adequate stock of consumable such as the lubricating oil and transformer oil should be maintained.

To avoid downtime, stock of fast moving spares and of spares likely to be damaged by short circuit should be maintained. A set of recommended spares for two years of trouble free operation should be ordered alongwith the equipments.

Tools such as crimping tools, soldering, brazing and usual electrical tools should be available.

Usual test equipment such as megger, AVO-meter (Multi-meter), tong tester, vibration-tester, noise level tester, tachometer should be available.

9.11.2 Preventive Maintenance

For preventive maintenance, it is advisable to follow a schedule for the maintenance of the equipments. The schedule covers recommendations for checks and remedial actions to be observed at different periodicities such as daily, monthly, quarterly, semi-annually, annually and bi-annually.

9.11.2.1 DAILY

a) Motors

- i) Check bearing temperatures
- ii) Check for any undue noise or vibration.

b) Panel, Circuit-Breaker, Starter

- i) Check the phase-indicating lamps
- ii) Note readings of voltage, current, frequency, and others
- iii) Note energy-meter readings.

c) Transformer Substation

- i) Note voltage and current readings.

9.11.2.2 MONTHLY

a) Motor :- nothing special other than the daily checks**b) Panel, Circuit Breaker, Starter**

- i) Examine contacts of relay and circuit-breaker Clean, if necessary
- ii) Check setting of over-current relay, no-volt coil and tripping mechanism and oil in the dash-pot relay.

c) Transformer Substation

- i) Check the level of the transformer oil
- ii) Check that the operation of the GOD is okay
- iii) Check contacts of GOD and of OC
- iv) Check temperatures of the oil and windings
- v) Clean radiators to be free of dust or scales
- vi) Pour 3 to 4 buckets of water in each earth-pit.

9.11.2.3 QUARTERLY

a) Motor

- i) Blow away dust and clean any splashing of oil or grease
- ii) Check wear of slip ring and brushes; smoothen contact-faces or replace, if necessary. Check spring-tension. Check brush-setting for proper contact on the slip-ring

- iii) Check cable connections and terminals and insulation of the cable near the lugs, clean all contacts, if insulation is damaged by overheating investigate and rectify. All contacts should be fully tight.

b) *Panel, Circuit-Breaker, Starter and others*

- i) Check fixed and moving contacts of the circuit-breakers/switches. Check and smoothen contacts with fine glass-paper or file
- ii) Check condition and quantity of oil/liquid in circuit-breaker, auto-transformer starter and rotor-controller.

c) *Transformer Substation*

- i) Check condition of the H.T.bushing
- ii) Check the condition of the de-hydrating breather and replace the silicagel charge, if necessary. Reactivate old charge for reuse

9.11.2.4 SEMI-ANNUAL

a) *Motor*

- i) Check condition of oil or grease; and replace if necessary. While greasing avoid excessive greasing
- ii) Test insulation by megger.

b) *Panel and others*

Nothing special.

c) *Transformer Substation*

- i) Check die-electric strength and acid-test of transformer oil and filter, if necessary
- ii) Test insulation by megger
- iii) Check continuity for proper earth connections.

9.11.2.5 ANNUAL

a) *Motors*

- i) Examine bearings for flaws, clean and replace if necessary
- ii) Check end-play of bearings and reset by lock-nuts, wherever provided.

b) *Panel and others*

- i) All indicating meters should be calibrated

c) **Transformer Substation**

- i) Check resistance of earth pit/earth electrode

9.11.2.6 BI-ANNUAL

- a) **Motor** same as annual

- b) **Panel and others** same as annual

c) **Transformer Substation**

- i) Complete examination including internal connections, core and windings

9.12 TROUBLE SHOOTING FOR ELECTRICAL EQUIPMENTS

Trouble-shooting comprises of detecting the trouble, diagnosing the cause and taking remedial action. Detection of the trouble is prompted by noticing symptoms. The trouble- shooting details are hence outlined here below for various symptoms.

9.12.1 Symptom 1 : Motor Gets Overheated

- i) Check whether voltage too high or too low
- ii) Change tapping of transformer, if HT supply is availed. Otherwise approach power supply authorities for correction of the supply voltage
- iii) Check whether air ventilation passage of motor is blocked. Clean the passage
- iv) Check whether the motor bearings are improperly lubricated or damaged
- v) Check bearings for damage and lubrication
- vi) Check whether the cable terminals at the motor are loose
Tighten the terminals

9.12.2 Symptom 2 : Motor Gets Overloaded

- i) Check for any friction
- ii) Check whether characteristics of pump (i.e. the related driven equipment) are of the overloading type
- iii) Check for any vortices in the sump
- vi) Check that there is no short-circuiting or single phasing
- v) Check whether any foreign matter has entered the airgap, causing obstruction to the smooth running of the motor

9.12.3 Symptom 3 : Starter/Breaker Trips

- i) Check whether the relay is set properly. Correct the setting, if necessary

- ii) This can happen also if motor is getting over- loaded for which details are mentioned above
- iii) Tripping can also be due to short-circuiting or single-phasing, which are also discussed above
- iv) Oil in dashpot relay may be either inadequate or of low viscosity
- v) Check that there are no loose connections
- vi) Check whether the timer setting of star delta or auto transformer starter are proper

9.12.4 Symptom 4 : Vibration in Motor

- i) Check for rigidity of supporting frame and foundation
- ii) Check alignment of pump and motor
- iii) Check that the nuts on foundation bolts are tight
- iv) Check if rotor has an imbalance
- v) Check for resonance from supporting structure or foundation or from critical speed of rotor or from vibration of adjoining equipment

9.12.5 Symptom 5 : Cables Get Overheated

- i) Check whether the cable is undersized. Change the cable or provide another cable in parallel
- ii) Check for loose termination of joint. Fasten the termination and make proper joint
- iii) Check whether only a few strands of the cable are inserted in the lug. Insert all strands using a new lug, if necessary

CHAPTER 10

BASIC DESIGN CONSIDERATIONS

The object of sewage treatment is to stabilize decomposable organic matter present in sewage so as to produce an effluent and sludge which can be disposed of in the environment without causing health hazards or nuisance. Before proceeding with the design of the treatment plant, it is essential to know the variations in quantity and characteristics of the raw sewage and the quality of the final effluent desired.

10.1 DEGREE OF TREATMENT

The degree of treatment will mostly be decided by the regulatory agencies and the extent to which the final products of treatment are to be utilised. These regulatory bodies might have laid down standards for the effluent or might specify the conditions under which the effluent could be discharged into a natural stream, sea or disposed of on land. These regulatory bodies may be the local body or a State Pollution Control Board. The method of treatment adopted should not only meet the requirements of these regulatory agencies but also result in the maximum use of end products consistent with economy.

10.2 DESIGN PERIOD

The treatment plant, like the sewerage system is normally designed to meet the requirements over a 30 year period after its completion. The time lag between the design and the completion should not ordinarily exceed 2 to 3 years and even in exceptional circumstances 5 years. It is suggested that the construction of Sewage Treatment Plant may be carried out in phases with an initial design period ranging from 5 to 10 years excluding the construction period, so that the expenditure far ahead of utility is avoided. Care should be taken to see that the plant is not considerably under loaded in the initial stages, particularly the sedimentation tanks. The comparative merits to cover the full 30 year period versus the first 15 years or earlier should be examined to decide on the most economical initial arrangement satisfactory to cover the first 15 years or lesser. Even though some mechanical units may not be constructed in the beginning, enough provision should be made in the civil structures for their installation at a later date.

The treatment plant should be considered as a part of the main sewerage project and the area to be served is to be decided based on the needs of the main project itself. The main project may not be executed at one stretch but may be done in stages as the development of the area takes place. But in any case, the ultimate period of design of the project should be 30 years and to that extent sufficient accommodation should be provided for all the units necessary to cater to the needs of this ultimate population. In some cases, it may be necessary to combine a number of sewerage systems with a common sewage treatment plant.

This should naturally be considered in the main sewerage project itself and if the treatment plant is to cater to the needs of such additional areas at a later date enough provision should be made for accommodating the expansion in the beginning itself. Zoning regulations particularly as they affect the use of undeveloped land including the possible changes in the use of lands already developed may be important. It may be planned to combine treatment of the waste from a nearby industry along with the community wastes from the urban area. In such cases, it should be carefully investigated whether liquid wastes from the industry do not adversely affect either the sewerage system or the treatment process and could be accepted, if necessary with some preliminary treatment, so that it could be combined with the sewage from the community for a unified and economical treatment.

10.3 POPULATION SERVED

Estimates for present and future population of areas involved in the project are made to determine the quantity of sewage to be treated. These estimates would have formed a part of the main sewerage project itself as in Chapter 3.

10.4 SEWAGE FLOWS

The quantity of sewage and its characteristics show a marked range of hourly variation and hence peak, average and minimum flows are important considerations. The process loadings in the sewage treatment are based on the daily average flows and the average characteristics as determined from a 24 hour weighted composite sample. In the absence of any data, an average flow of 150 lpcd may be adopted. The hydraulic design load varies from component to component of the treatment plant with all appurtenances, conduits, channels etc. being designed for the maximum flow which may vary from 2.0 to 3.5 times the average flow. Sedimentation tanks are designed on the basis of average flow, while consideration of both maximum and minimum flow is important in the design of screens and grit chambers.

10.4.1 Population Equivalent

The population equivalent is a parameter useful in the conversion of the contribution of wastes from industrial establishments for accepting into the sanitary sewer systems by the authorities concerned and serves as a basis for levying an equitable charge for the same. The average daily per capita contribution of suspended solids and BOD₅ are 90 gms and 45 gms respectively which is used for estimating population equivalents.

10.5 SEWAGE CHARACTERISTICS

Characterisation of wastes is essential for an effective and economical waste management programme. It helps in the choice of treatment methods deciding the extent of treatment, assessing the beneficial uses of wastes and utilizing the waste purification capacity of natural bodies of water in a planned and controlled manner. While analysis of waste in each particular case is advisable, data from other cities may be utilised during initial stages of planning.

Domestic sewage comprises spent water from kitchen, bathroom, lavatory etc. The factors which contribute to variations in characteristics of the domestic sewage are daily per capita water use, quality of water supply and the type, condition and extent of sewerage system and habits of the people. Municipal sewage which contains both domestic and industrial waste water may differ from place to place depending upon the type of industries and number of industrial establishments. The important characteristics are discussed here after.

10.5.1 Temperature

Observation of temperature of sewage is useful in indicating the solubility of oxygen which affects oxygen transfer capacity of aeration equipments and rate of biological activity. Extremely low temperature affects adversely the efficiency of sedimentation. Normally the temperature of domestic and municipal sewage is slightly higher than that of the water supply.

10.5.2 Hydrogen Ion Concentration

The hydrogen ion concentration, more conveniently expressed as pH, is a valuable parameter in the operation of biological units. The pH of fresh domestic sewage is slightly more than that of the water supply to the community. However, the onset of septic conditions may lower the pH while the presence of industrial wastes may produce extreme fluctuations.

10.5.3 Colour and Odour

Fresh domestic sewage has a slightly soapy and earthy odour and cloudy appearance depending upon its concentration. With passage of time, the sewage becomes stale, darkening in colour with a pronounced smell due to microbial activity.

10.5.4 Solids

Though sewage contains only 0.1 percent solids, the rest being water, still the nuisance caused by the solids cannot be overlooked, as they are highly putrescible and therefore need proper disposal. The sewage solids may be classified into suspended and dissolved fractions which may be further subdivided into volatile and non-volatile solids. A knowledge of the volatile or organic fraction of solid which is putrescible becomes necessary as this constitutes the load on biological treatment units or oxygen resources of a stream when sewage is disposed of by dilution. The estimation of suspended solids, both organic and inorganic, gives a general picture of the load on sedimentation and grit removal processes in sewage treatment. Dissolved inorganic fraction is to be considered when sewage is used for land irrigation or reuse of sewage is planned.

10.5.5 Nitrogen

The principal nitrogenous compounds in domestic sewage are proteins, amines, amino-acids and urea. Ammonia nitrogen in sewage results from the bacterial decomposition of these organic constituents. Nitrogen being an essential component of biological protoplasm, its determination in wastes is necessary for proper biological treatment or land irrigation. Where nitrogen content is inadequate, it becomes necessary to supplement with addition of salts containing nitrogen. Generally domestic sewage contains sufficient nitrogen, to take care of the needs of the biological treatment.

10.5.6 Phosphorus

Phosphorus is contributed to domestic sewage from food residues containing phosphorus and their breakdown products. The use of increased quantities of synthetic detergents add substantially to the phosphorus content of sewage. Phosphorus just as nitrogen, is an essential nutrient for biological processes. Generally domestic sewage contains adequate quantities of phosphorus.

10.5.7 Chlorides

Concentration of chlorides in sewage above the normal chloride content of water supply is used as an index of the strength of the sewage. The daily contribution of chlorides averages to about 8 gm per person. Based on an average sewage flow of 150 lpcd, this would result in the chloride content of sewage being 50 mg/l higher than that of the water supplied. Any abnormal increase should indicate discharge of chloride bearing wastes or saline ground water infiltration, the latter adding to the sulphates which may lead to excessive generation of hydrogen sulphide.

10.5.8 Biochemical Oxygen Demand

The Biochemical Oxygen Demand (BOD) of sewage or of polluted water is the amount of oxygen required for the biological decomposition of biodegradable organic matter under aerobic conditions. The oxygen consumed in the process is related to the amount of decomposable organic matter. Greater reliance is placed on BOD test as compared to determination of volatile solids when putrescibility of the sewage is to be determined. The standard BOD test is carried out for a period of 5 days at 20° C and is expressed as BOD₅.

10.5.9 Chemical Oxygen Demand

The Chemical Oxygen Demand (COD) test gives a measure of the oxygen required for chemical oxidation. This test does not differentiate between biologically oxidisable and nonoxidisable

material. However, the ratio of the COD to BOD does not change significantly for a particular waste and hence this test could be used conveniently for interpreting performance efficiencies of the treatment units. In situations where the presence of toxic materials is likely to interfere with the BOD, this test is very useful.

10.5.10 Toxic Metals and Compounds

Some heavy metals and compounds such as chromium, copper, cyanide, which are toxic may find their way into municipal sewage through industrial discharges. Determinations of these assume importance if such waste is to be treated by biological process or disposed of in stream or on land.

10.6 EFFECT OF INDUSTRIAL WASTES

Wastes from industries can form an important component of sewage flows both in volume and composition. It is therefore necessary that detailed data about the nature of the industries, the quantity and the character of the wastes and their variations which may affect the sewerage system or the sewage treatment process are collected. Quantity and character of wastes are to be based on flow measurements and laboratory analysis of the composite samples. Where water reclamation is to be practised, due consideration is to be given to the effect of industrial waste components on the final effluent.

Industrial waste containing solids which might clog conduits or damage pumping equipment usually require treatment prior to their entry into the sewer. These substances include ash, cinder, sand, mud, straw shavings, metal, glass, rags, feathers, tar, plastics, wood, hair, fleshings, chemical residues, etc. Condensates, on the other hand, though clear in appearance may contain high dissolved organic and mineral matter adding to the load on the secondary treatment processes and reclamation of water.

In cases where wastes high in suspended solids and BOD are to be accepted, provision should be made in the design of the treatment plant to handle such wastes. In certain instances, it is more economical to tackle the industrial waste at the source itself. Where the wastes have a high or low pH, corrective measures are necessary before admitting them to the sewers or the treatment plant. Toxic metals and chemicals having adverse effects on biological treatment processes or upon fish life in a natural water course or render the receiving water unfit as a source of water supply, should be brought down to acceptable limits at the source itself. Grease and oils in excessive amounts not only add considerably to the cost of treatment, but also pose a disposal problem. Where additional service charges are imposed by the local authorities for wastes that are overstrength in suspended solids, BOD or other characteristics, the industry may find it desirable to install equipment which will eliminate a considerable proportion of the overstrength characteristics and reduce service charges.

The industrial wastewater may be discharged into public sewers if the industrial effluents meet the tolerance limits as prescribed by IS:3306-1974. If wastewaters are to be discharged into inland surface waters, tolerance limits set by IS:2490-1963 are to be satisfied. For industrial effluents to be discharged on land for irrigation purposes, BIS code IS:3307-1965 should be followed.

10.7 DUMPING CHUTES FOR NIGHTSOIL

Detachable dumping chutes are constructed at selected points in the sewerage system for disposing of the nightsoil collected from individual houses or through vacuum cars from collection wells in towns which are only partially sewered. These discharges have the effect of increasing the concentration of solids and BOD and, where necessary, sufficient dilution must be provided to prevent the clogging of the sewers. In such cases, the treatment plant will have to provide for the change in the characteristics of the sewage. These dumping chutes should be scrapped when the sewerage system is expanded to cover the unsewered areas.

10.8 EFFLUENT DISPOSAL AND UTILISATION

The sewage after treatment may be disposed either into a water body such as lake, stream, river, estuary and ocean or onto land. It may also be utilised for several purposes such as (i) Industrial reuse or reclaimed sewage effluent in cooling systems, boiler feed, process water etc.. (ii) Reuse in agriculture and horticulture, watering of lawns, golf courses and such purposes and (iii) Ground water recharge for augmenting ground water resources for downstream users or for preventing saline water intrusion in coastal areas. For detailed discussion, reference should be made to chapters on Tertiary Treatment of Sewage for Reuse and on Effluent Disposal and Utilisation and on Sewage Farming. Another use of sewage effluent may be at the treatment plant itself for purposes, such as, flushing and foam control, chlorinator injector water, lawn sprinkling, fire protection (with necessary safe-guards) and general plant operation.

If sewage effluent is to be discharged into inland surface waters, tolerance limits prescribed by statutory agencies, IS 4764-1973 should be followed.

10.9 UNIT OPERATIONS, PROCESSES AND REACTOR DESIGN PRINCIPLES

10.9.1 Unit Operations and Processes

The removal of contaminants is brought by a sequential combination of various physical unit operations and chemical and biological unit processes. The physical unit operations include screening, grit removal and sedimentation. The chemical processes including chemical coagulation followed by flocculation are not usually used for treatment of domestic wastewaters. The biological processes can be broadly classified as (i) suspended growth processes, both aerobic and anaerobic, including activated sludge process, extended aeration, lagooning, nitrification, denitrification and anaerobic digestion and (ii) attached growth processes such as aerobic and anaerobic filter processes.

The unit operations and processes commonly employed in domestic wastewater treatment, their functions and units used to achieve these functions are listed in Table 10.1.

10.9.2 Reactors

Any container or vessel in which chemical and/or biological reactions occur can be termed as a reactor. A test tube, river, lake or aeration tank of biological process are all examples of reactors. In domestic wastewater treatment biological reactors are extensively used for oxidation of organic matter through enzyme-mediated biochemical reactions. Reactors are basically classified as:

- i) Batch Reactors
- ii) Complete-Mix Flow (CMF) Reactors or Continuously stirred Tank Reactors (CSTR)
- iii) Plug Flow (PF) Reactors
- iv) Plug Flow with Dispersion (PFD) Reactors or Arbitrary Flow Reactors.

In batch reactors, the flow neither enters nor leaves the reactor on continuous basis. Complete-Mix Flow reactors are ideal reactors in which the contents are completely mixed and no concentration gradients exist. Flow enters and leaves on continuous basis. The substances present in the fluid are instantaneously and thoroughly mixed in CMF reactor and the concentration of a substance in the effluent is same as that in the reactor.

TABLE 10.1
UNIT OPERATIONS/PROCESSES, THEIR FUNCTIONS AND DEVICES
USED FOR DOMESTIC WASTEWATER TREATMENT

Sl. No.	Unit Operations and Process	Functions	Treatment Devices
1	SCREENING	Removal of large floating, suspended and settleable solids	Bar racks and screens of various description
2	GRIT REMOVAL	Removal of inorganic suspended solids	Grit chamber
3	PRIMARY SEDIMENTATION	Removal of organic and inorganic settleable solids	Primary sedimentation tank
4 (a)	AEROBIC BIOLOGICAL SUSPENDED GROWTH PROCESS	Conversion of colloidal, dissolved and residual suspended organic matter into settleable biofloc and stable inorganics	Activated sludge process units and its modifications, Waste Stabilisation Ponds, Aerated Lagoons
(b)	AEROBIC BIOLOGICAL ATTACHED GROWTH PROCESS	Same as above	Trickling Filter, Rotating Biological Contactor
5.	ANAEROBIC BIOLOGICAL GROWTH PROCESSES	Conversion of organic matter into CH ₄ & CO ₂ and organic relatively stable organic residue	Anaerobic Filter, Fluid-Bed Submerged Media Anaerobic Reactor, Upflow Anaerobic Sludge Blanket Reactor, Anaerobic Rotating Biological Contactor
6.	ANAEROBIC STABILIZATION OF ORGANIC SLUDGES	Same as above	Anaerobic Digester

On the contrary, the ideal plug-flow reactors are characterised by complete lack of mixing in the direction of flow. Therefore, the concentration of a substance continuously changes in the direction of flow and concentration gradients exist. It is generally assumed that the contents of ideal plug-flow reactors are well mixed in transverse/lateral/radial direction. The Plug-Flow with Dispersion (PFD) reactor has intermediate or arbitrary degree of mixing. The degree of mixing in PFD reactors is in between Plug-Flow (zero or no mixing) and complete mix (infinite mixing) reactors.

10.9.3 Biological Reactor Design

Biological reactors are reactors in which organic matter which serves as substrate or food to micro organisms is utilized for the growth of micro organisms. The most widely used expression for the growth rate of microorganisms is given by Monod:

Total rate of Microbial Growth,

$$\frac{dx}{dt} = \frac{\mu_m XS}{K_s + S} \quad (10.1)$$

- where, μ_m = maximum specific growth rate, T^{-1}
 X = microorganism concentration, ML^{-3}
 S = substrate (food) concentration, ML^{-3}
 K_s = half-velocity constant or that substrate concentration at one half the maximum growth rate, ML^{-3}

similarly

Rate of substrate utilization,

$$\frac{dS}{dt} = -\frac{kXS}{K_s + S} \quad (10.2)$$

Where

- k = maximum specific substrate utilization rate, T^{-1}

Net growth rate of microorganisms is computed by subtracting from the total growth rate the rate of microorganisms endogenously respired or decayed. Therefore,

$$\text{Net rate of microbial growth} = \frac{\mu_m XS}{K_s + S} - k_d X \quad (10.3)$$

where k_d is endogenous decay coefficient, T^{-1}

The maximum specific growth rate, μ_m , and maximum specific substrate utilization rate, k , are related to each other as

$$\mu_m = Y \cdot k \quad (10.4)$$

Where Y is maximum yield coefficient and is defined as the ratio of maximum mass of cell formed to the mass of substrate utilized. The coefficients Y , k_d , k and k_s are designated as kinetic coefficients.

The values of kinetic coefficients depend upon the nature of wastewater and the operational and environmental conditions in the biological reactor. The biological reactors can be CMF, PF or PFD reactors with or without cellular recycle. For biological reactors with cellular recycle, the time for which microorganisms stay in the reactor (Θ_c) is not the same as the time for which water remains in the reactor (Θ).

Hydraulic Residence Time,

$$\text{HRT } (\Theta) = \frac{\text{Volume of Reactor, } (v)}{\text{Flow rate } (Q)}$$

$$= \frac{V}{Q} \quad (10.5)$$

$$\text{Mean Cell Residence Time, MCRT } (\Theta_c) = \frac{\text{Mass of Cells in Reactor, } VX}{\text{Mass of cells wasted per day}}$$

Mean cell residence time is also termed as Biological Solids Retention Time (BSRT or SRT) or sludge age.

Table 10.2 presents expressions for effluent substrate concentrations, microorganisms concentration and mean cell residence time for various types of biological reactor with or without recycle. These equations can be used for analysing and designing the biological reactors on rational basis.

TABLE 10.2
BASIC EQUATIONS FOR BIOLOGICAL REACTORS

Types of Biological Reactor	Effluent substrate concentration	Micro-organism Concentration, X	Mean Cell residence time
Complete - Mix Flow Reactor without cellular recycle	$\frac{K_s(1+\theta k_d)}{\theta(Yk - k_d) - 1}$	$\frac{Y S_0 S}{1 + K_d \theta}$	$\theta_c \theta \frac{V}{Q}$
Complete - Mix Flow Reactor without cellular recycle	$\frac{K_s(1+\theta_c k_d)}{\theta_c(Yk - k_d) - 1}$	$\frac{\theta_c X S_0 S}{\theta(1 + k_d \theta)}$	$\frac{VX}{Q_{wa} X + (Q - Q_{wa}) X_e}$
Plug Flow Reactor with cellular recycle		$\frac{\theta_c X S_0 S}{\theta(1 + k_d \theta)}$	$\frac{1}{\theta_c} \frac{Y X S_0 S}{(S_0 S + (1 - \alpha) K_d) \log_e \frac{S_i}{S}} - k_d$

Where S_o = influent substrate concentration, ML^{-3}

α = ratio of recycled sludge flow to wastewater flow, dimensionless

S_i = influent concentration to reactor after dilution with recycle flow.

$$= \frac{S_o + \alpha S}{1 + \alpha} \quad ML^{-3}$$

S = effluent substrate concentration, ML^{-3}

$Q_{w,a}$ = Sludge wastage rate from reactor, L^3T^{-1}

It is important to note that if the order of reaction kinetics is higher than zero, the plug flow reactor is more efficient than the CMF reactor under similar conditions.

10.9.4 Design of Process Flow Sheets

The design of process flow sheet involves selection of an appropriate combination of various unit operations and unit processes to achieve a desired degree of contaminant removal. The selection of unit operations and processes primarily depends on the characteristics of raw wastewater and the required levels of contaminants permitted in the processed effluents. The design of process flow sheets is very important step in the overall design of wastewater treatment and requires a thorough understanding of the treatment units and associated unit operations/processes alongwith the mechanisms involved and performance levels attainable under variable conditions. It calls for optimization of wastewater treatment system coupled with stagewise optimal design of individual operation/process to achieve a minimal cost design.

The main contaminants in domestic wastewater to be removed are biodegradable organics, as usually measured by BOD, suspended solids and pathogens with the first two having been traditionally considered as the performance indicators for various treatment units. It is generally the objective of domestic wastewater treatment plant to produce treated effluents having BOD_5 of 30 mg/l or less and suspended solids of 50 mg/l or less for disposal into inland water bodies.

The conventional process flow sheet of municipal wastewater treatment plant comprises the unit operations of screening, grit removal and primary sedimentation followed by unit process of aerobic biological treatment usually achieved by activated sludge process or trickling filter followed by secondary sedimentation. The sludges removed by primary and secondary sedimentation are digested anaerobically followed by drying of anaerobically digested sludge on sand sludge drying beds. This process flow sheet is depicted in Fig.10.1.

It is possible to replace the activated sludge process or trickling filter process by low cost treatment devices such as oxidation ditch, aerated lagoon or waste stabilization ponds. Such treatment devices obviate the necessity of some of the unit operations and processes like primary sedimentation and anaerobic digestion. Some of the process flow sheets are shown in Fig.10.2 to 10.4.

With the better understanding of microbiology and biochemistry of anaerobic treatment, it is now feasible to treat dilute organic wastewater such as domestic wastewater also directly through anaerobic treatment using recently developed innovative devices such as Upflow Anaerobic Sludge Blanket Reactor (UASBR), Fluid-Bed Submerged Media Anaerobic Reactor (FB-SMAR) and Anaerobic Filter (AF) or Static-Bed SMAR(SB-SMAR) and Anaerobic Rotating Biological Contactor (AnRBC). Though enough field data is to be generated as yet on their performance, it is generally reported that BOD_5 removal efficiencies may range from 60-80%. Consequently post treatment will generally be required to achieve the prescribed effluent standards. The process flow sheet is depicted in Fig 10.5.

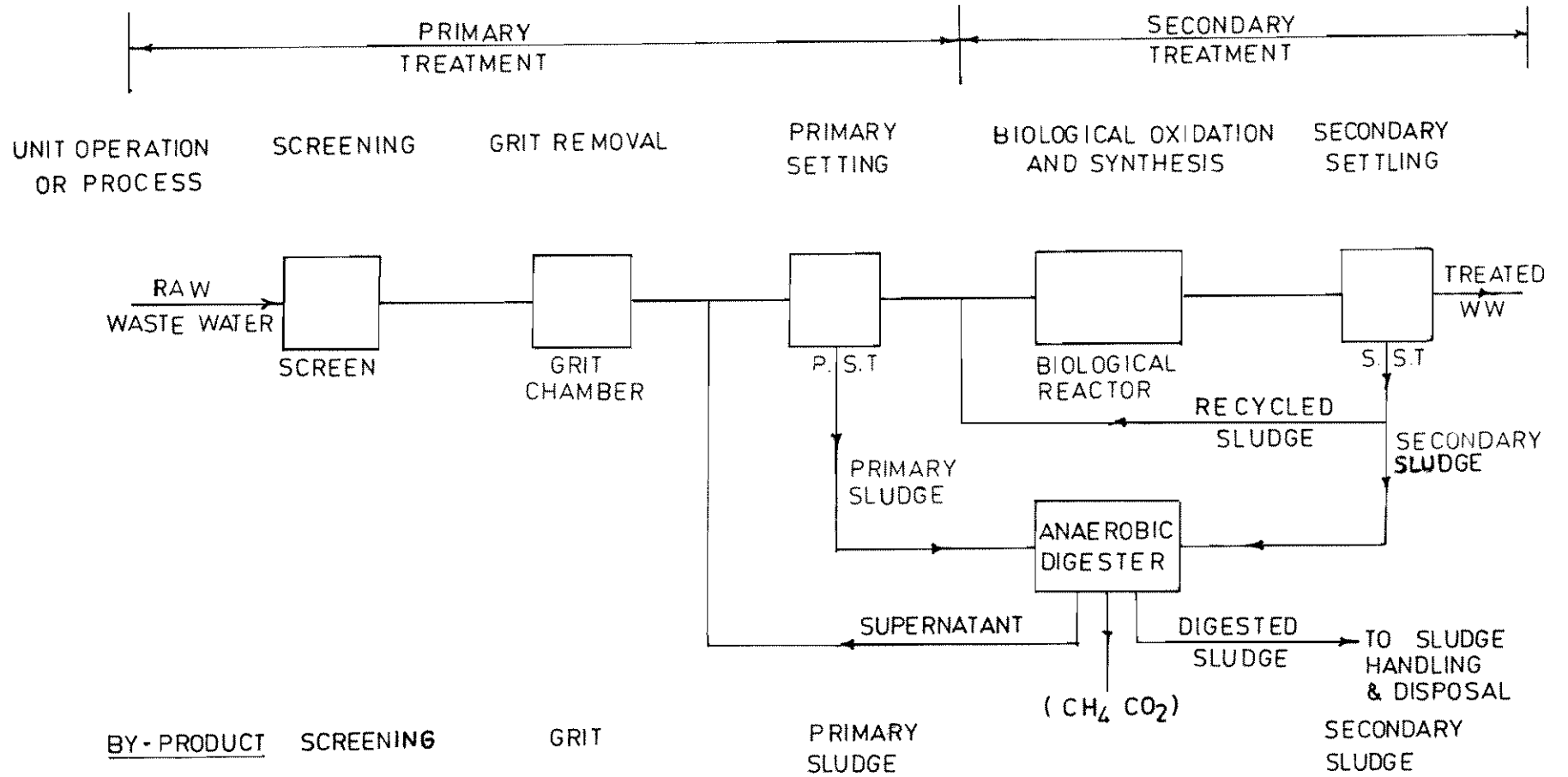

FIG.101:PROCESS FLOWSHEET OF CONVENTIONAL DOMESTIC WASTE WATER TREATMENT

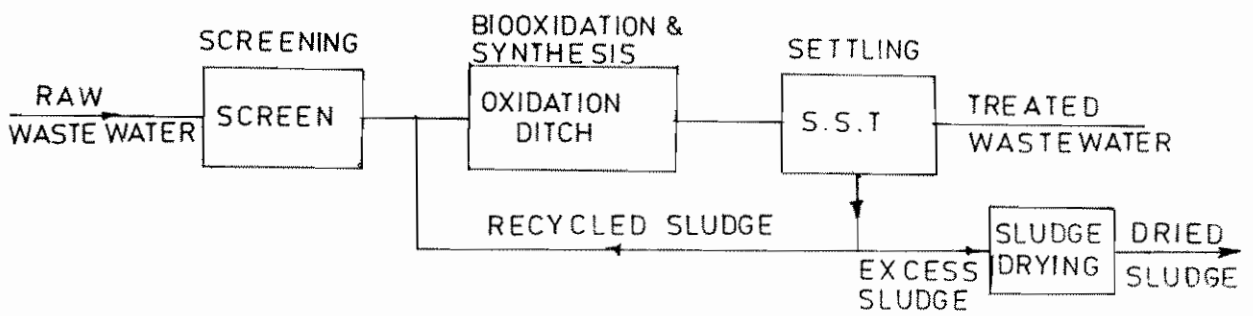

FIG.102: PROCESS FLOWSHEET INCORPORATING OXIDATION DITCH

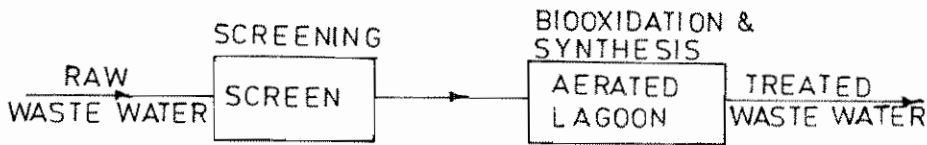

FIG.103: PROCESS FLOWSHEET EMPLOYING AERATED LAGOON

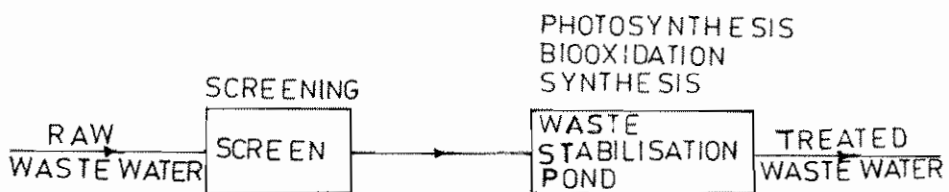

FIG.10.4: PROCESS FLOWSHEET USING WASTE STABILISATION POND

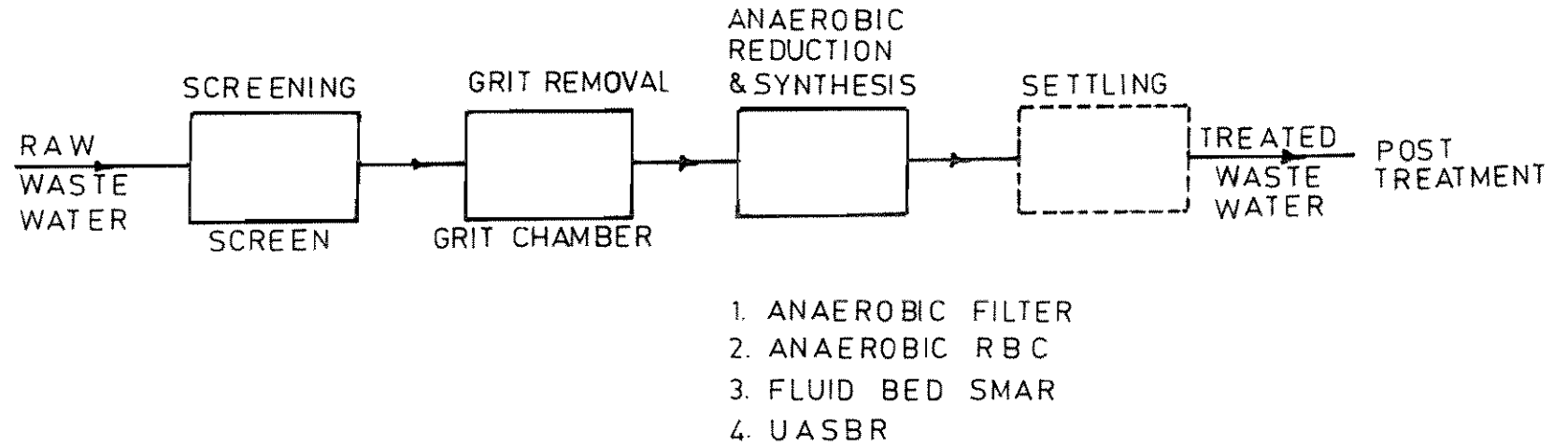

FIG.10.5: PROCESS FLOW SHEET EMPLOYING ANAEROBIC TREATMENT DEVICES

10.10 CHOICE OF PROCESSES

Sewage treatment processes may be generally classified as primary, secondary and tertiary. The general yardstick of evaluating the performance of sewage treatment plants is the degree of reduction of BOD, SS and Total Coliforms. The efficiency of a treatment plant depends not only on proper design and construction but also on good operation and maintenance. Expected efficiencies of various treatment units are given Table 10.3.

TABLE 10.3
EXPECTED EFFICIENCIES OF VARIOUS TREATMENT UNITS

Process	Percentage Reduction		
	SS	BOD	Total Coliform
1. Primary Treatment (Sedimentation)	45-60	30-45	40-60
2. Chemical Treatment	60-80	45-65	60-90
3. Secondary Treatment			
(i) Standard trickling filters	75-85	70-90	80-90
(ii) High rate trickling filters			
(a) Single Stage	75-85	75-80	80-90
(b) Two Stage	90-95	90-95	90-60
(iii) Activated sludge plants	85-90	85-95	90-96
(iv) (a) Stabilisation ponds (Single Cell)		90-95	90-95
	80-90		
(b) Stabilisation ponds (Two Cells)	90-95	95-97	95-98

Tertiary treatment is adopted when reuse of effluent for industrial purposes is contemplated or when circumstances dictate the requirement of higher quality effluents.

Cost is the prime consideration in the selection of the treatment method. It should include the cost of installation, capitalised cost of maintenance and operation taking into account interest charges and period of amortisation. An alternative will be to consider the annual cost covering amortisation and interest charges for the loan obtained for the installation together with the annual operating and maintenance costs. In some cases there is a component of subsidy granted by the Government for the installation of the treatment works and the maintenance cost is borne entirely by the local body or the agency concerned. Both these will have to be taken into account for making realistic comparison of the alternatives.

Other factors that may influence are ease of construction and maintenance, benefits that accrue from better environmental sanitation, location, availability of land and topographical conditions.

CHAPTER 11

PRETREATMENT - SCREENING AND GRIT REMOVAL

Pre-treatment consists of separation of floating and suspended organic and inorganic material by physical processes such as (a) screening by which materials larger in size than the openings of the screening device is strained out; and (b) grit removal by which coarse particles of ash and other inert material which have subsidence velocities substantially greater than those of organic putrescible solids are removed.

11.1 SCREENING

Screening is an essential step in sewage treatment for removal of materials which would otherwise damage equipment, interfere with the satisfactory operation of treatment units or equipment or cause objectionable shoreline conditions where disposal into sea is practised. Screens are used ahead of pumping stations, meters and as a first step in all treatment works.

A screen is a device with openings generally of uniform size for removing bigger suspended or floating matter in sewage. The screening element may consist of parallel bars, rods, gratings or wiremeshes or perforated plates and the openings may be of any shape although generally they are circular or rectangular screens may be coarse, medium or fine.

11.1.1 Coarse Screens

They serve more as protective devices in contrast to fine screens which function as treatment devices. Coarse screens are usually bar screens and sometimes used in conjunction with comminuting devices.

A bar screen is composed of vertical or inclined bars spaced at equal intervals across a channel through which sewage flows. It is usual to provide a bar screen with relatively large openings of 75 to 150mm and ahead of the pumps for raw sewage while those preceding the primary sedimentation tanks have smaller openings of 50mm. Bar screens with large openings are often termed coarse racks or trash racks. Their principal function is to prevent the entry of floating matter like logs, timber or large sized material, carcasses, rags, etc., that is brought in by the flowing sewage.

Bar screens are usually hand cleaned and sometimes provided with mechanical devices. These cleaning devices are rakes which periodically sweep the entire screen removing the solids for further processing or disposal. Some mechanical cleaners utilise endless chains or cables to move the rake teeth through the screen openings. Screenings are raked to a platform with perforations which permits the drainage of water back to the unit. Hand cleaned racks are set usually at an angle of 45 degrees to the horizontal to increase the effective cleaning surface and also facilitate the raking operations. Experience indicates that the area of the vertical projections of the space between the bars measured across the direction of the flow should be about twice the areas of the sewer.

Mechanically cleaned racks are generally erected almost vertically. Such bar screens have openings 25% in excess of the cross section of the sewage channel. Their area is usually half of that required for hand raked screens. Fabrication of screens should be such that bolts, cross bars, etc., will not interfere with raking operations. Additional provision should be available for manual raking to take care of the situations where the mechanical rakes are temporarily out of order. Plants using mechanically cleaned screens have controls for (a) manual start and stop (b) automatic start and stop by clock control (c) high level switch (d) high level alarm (e) starting switch or overload switch actuated by loss of head and (f) overload alarm.

11.1.2 Medium Screens

Medium bar screens have clear openings of 20 to 50mm. Bars are usually 10mm thick on the upstream side and taper slightly to the downstream side. These mechanically raked units are used before all pumps or treatment units such as the stabilization ponds. The bars used for the screens are rectangular in cross-section usually about 10mm x 50mm and are placed with the larger dimension parallel to the flow. A weir on the side of the screen may be used as an overflow bypass.

11.1.3 Fine Screens

Fine screens are mechanically cleaned devices using perforated plates, woven wire cloth or very closely spaced bars with clear openings of less than 20mm. Fine screens are used for pretreatment of industrial wastes to remove materials which tend to produce excessive scum or foam on the top of digestion tank contents. Fine screens are not normally suitable for sewage because of the clogging possibilities.

Fine screens may be of the drum or disc type, mechanically cleaned and continuously operated. Fine screens have generally a net submerged open area of not less than 0.05 m^2 for every 1000 m^3 of average daily flow of sewage from a separate system, the corresponding figure being 0.075 m^2 for combined systems. They are also used for beach protection where sewage without any further treatment is discharged into sea for disposal by dilution.

11.1.4 Comminuting Devices

A comminuting device is a mechanically cleaned screen which incorporates a cutting mechanism that cuts the retained material enabling it to pass along with the sewage. The solids from the comminutor may, however, lead to the production of more scum in the digester.

11.1.5 Location of Screens

Screening devices are usually located where they are readily accessible because the nature of materials handled requires frequent inspection and maintenance of the installation. Where screens are placed in deep pits or channels, it is necessary to provide sufficiently wide approaches from the top and ample working space for easy access and maintenance. Provision should be made for the location of penstocks and bypass arrangements for the screens.

11.1.6 Housing of Screens

The need for a structure to house the screening equipment depends on two factors viz., the design of the equipment and the climatic conditions. If climatic conditions are not severe and could be withstood by the equipment, the screen house can be omitted. Mechanically cleaned screens generally need suitable housing to protect the equipment, prevent accidents to operating personnel and improve the appearance of the treatment facility. Ventilation of the housing is necessary to prevent accumulation of moisture and removal of corrosive atmosphere.

11.1.7 Hydraulics

A screen by its very nature and function collects material which will impede flow. If the screen is cleaned continuously by mechanical arrangement, this interference will be kept to a minimum. Screens with periodic cleaning arrangements are likely to produce considerable damming effect leading to surges of relatively high flow soon after cleaning. The usually accepted design is to place the base of the screen several centimetres below the invert of the approach channel and steepen the grade of the influent conduit immediately preceding the screen.

11.1.8 Velocity

The velocity of flow ahead of and through a screen varies materially and affects its operation. The lower the velocity through the screen, the greater is the amount of screenings that would be removed from sewage. However, the lower the velocity, the greater would be the amount of solids deposited in the channel. Hence, the design velocity should be such as to permit 100% removal of material of certain size without undue depositions. Velocities of 0.6 to 1.2 mps through the open area for the peak flows have been used satisfactorily. When considerable amounts of storm water are to be handled, approach velocities of about 0.8 mps are desirable, to avoid grit deposition at the bottom of the screen, which might otherwise become inoperative when most needed during storm though lower value of 0.6 mps is used in current practice. Further, the velocity at low flows in the approach channel should not be less than 0.3 mps to avoid deposition of solids. A straight channel ahead of the screen insures good velocity distribution across the screen and maximum effectiveness of the device.

11.1.9 Head Loss

Head loss varies with the quantity and nature of screenings allowed to accumulate between cleanings. The head loss created by a clean screen may be calculated by considering the flow and the effective areas of the screen openings, the latter being the sum of the vertical projections of the openings. The head loss through clean flat bar screens is calculated from the following formula:

$$h = 0.0729 (V^2 - v^2) \quad (11.1)$$

in which

- h = head loss in m
- V = velocity through the screen in mps
- v = velocity before the screen in mps

Usually accepted practice is to provide loss of head of 0.15m but the maximum loss with clogged hand cleaned screen should not exceed 0.3 m. For the mechanically cleaned screen, the head loss is specified by the manufacturers.

Another formula often used to determine the head loss through a bar rack is Kirschmer's equation:

$$h = \beta (W / b)^{4/3} h_v \sin \Theta \quad (11.2)$$

where h = head loss, in m

β = bar shape factor which is assigned value of 2.42 for sharp edged rectangular bar 1.83 for rectangular bar with semicircle upstream, 1.79 for circular and 1.67 for rectangular bar with both u/s and d/s faces as semicircular.

W = maximum width of bar u/s of flow, m

b = minimum clear spacing between bars, m

h_v = velocity head of flow approaching rack, m

$$= (v^2 / 2g)$$

Θ = angle of inclination of rack with the horizontal

The head loss through fine screens is given by the formula

$$h = (1 / 2g) (Q / CA)^2 \quad (11.3)$$

in which

h = head loss, m

Q = discharge, m³/s

C = Coefficient of discharge (typical value 0.6)

A = effective submerged open area, m²

11.1.10 Quantity of Screenings

The quantity of screenings varies with the size of screen used and on the nature of sewage. Generally it has been found that the screenings from sanitary sewage vary from 0.0015m³/ml with screen sizes of 10cm to 0.015 m³/ml in case of 2.5cm size.

11.1.11 Disposal of Screenings

The methods of disposal of screenings could be burial or composting. The screenings should not be left in the open or transported in uncovered conveyors as it would create nuisance due to flies and insects. If conveyors are used, they should be kept as short as possible for sanitary reasons. Burial in trenches usually 7.5cm to 10cm deep is practised particularly in small installations. At large works, where sufficient land for burial is not available within a reasonable distance from the plant, screenings are incinerated either by utilising the sludge gas obtained from the digestion tank or by using oil fuel. Where possible, the screenings are transported and mixed with town refuse for production of compost.

11.2 GRIT REMOVAL

Grit removal is necessary to protect the moving mechanical equipment and pump elements from abrasion and accompanying abnormal wear and tear. Removal of grit also reduces the frequency of cleaning of digesters and settling tanks. It is desirable to provide screens or comminuting device ahead of grit chambers to reduce the effect of rags and other large floating materials on the mechanical equipment, in case of mechanised grit chambers. But, where sewers are laid at such depths as to make the location of grit chambers ahead of pumping units undesirable or uneconomical, only a bar screen is provided ahead of pumps, with grit chambers and other units following the pumps.

11.2.1 Composition of Grit

Grit in sewage consists of coarse particles of sand, ash and clinkers, egg shells, bone chips and many inert materials inorganic in nature. Both quality and quantity of grit varies depending upon (a) types of street surfaces encountered (b) relative areas served (c) climatic conditions (d) types of inlets and catch basins (e) amount of storm water diverted from combined sewers at overflow points (f) sewer grades (g) construction and condition of sewer system (h) ground and ground water characteristics (j) industrial wastes (k) relative use of dumping chutes or pail depots where night soil and other solid wastes are admitted to sewers and (l) social habits. The specific gravity of the grit is usually in the range of 2.4 to 2.65. Grit is nonputrescible and possesses a higher hydraulic subsidence value than organic solids. Hence it is possible to separate the gritty material from organic solids by differential sedimentation in a grit chamber.

11.2.2 Types

Grit chambers are of two types mechanically cleaned and manually cleaned. The choice depends on several factors such as the quantity and quality of grit to be handled, headloss requirements, space requirements, topography and economic considerations with respect to both capital and operating costs. In very small plants mechanisation may be uneconomical. But for all sewage treatment plants receiving flows over 10 mld mechanised grit removal units are preferred.

11.2.2.1 MECHANICALLY CLEANED GRIT CHAMBERS

These grit chambers are provided with mechanical equipment for collection, elevation and washing of grit which are operated either on a continuous or intermittent basis. Scraper blades or ploughs rotated by a motor drive, collect the grit settled on the floor of the grit chamber. The grit so collected is elevated to the ground level by several mechanisms such as bucket elevators, jet pump, screws and air lift. The grit washing mechanisms are also of several designs most of which are basically agitation devices using either water or air to produce washing action. In intermittently (normally once or twice a day) operated type, sufficient storage capacity to hold the grit between intervals of grit elevation should be provided.

11.2.2.2 MANUALLY CLEANED GRIT CHAMBERS

These should provide for adequate capacity for storage of grit between intervals of cleaning. These tanks should be cleaned at least once a week. The simplest method of removal is by means of shovel and wheel-barrows.

11.2.3 Aerated Grit Chambers

An aerated grit chamber is a special form of grit chamber consisting of a standard spiral flow aeration tank provided with air-diffusion tubes placed on one side of the tank, 0.6 to 1 m from the bottom. The grit particles tend to settle down to the bottom of the tank at rates dependent upon the particle size and the bottom velocity of roll of the spiral flow, which in turn is controlled by the rate of air diffusion through the diffuser tubes of the shape of the tank. The heavier grit particles with their higher settling velocities drop down to the floor whereas the lighter organic particles are carried with roll of the spiral motion and eventually out of the tank. The velocity of roll, however, should not exceed the critical velocity of scour of grit particles. Normally a transverse velocity of flow, not exceeding 0.4 to 0.6 mps at the top of the tank should satisfy this requirement for differential scour. No separate grit washing mechanism or control device for horizontal velocity is necessary in aerated grit chambers.

11.2.4 Design Data

The basic data essential for a rational approach to the design of grit chambers are hourly variations of sewage flow and typical values for minimum, average and peak flows. Since the grit chamber is designed for peak flows and the flow through velocity is maintained constant within the range of flow, successful design and operation of grit chamber calls for a fairly accurate estimation of the flows.

The quantity and quality of grit varies from sewage to sewage. Data relating to these two factors is very useful in proper design of grit collecting, elevating and washing mechanisms. In the absence of specific data, grit content may be taken as 0.05 to 0.15 m³/mL for domestic sewage and 0.06 to 0.12 m³/mL for combined sewage. The quantity may increase three to four fold during peak flow hours which may last for 1 to 2 hours.

11.2.5 Design of Grit Chambers

11.2.5.1 SETTLING VELOCITY

Grit chamber may be designed on a rational basis by considering it as a sedimentation basin. The grit particles are treated as discrete particles settling with their own settling velocities. The settling velocity is governed by the size and specific gravity of the grit particles to be separated and the viscosity of the sewage. The minimum size of the grit to be removed is 0.20mm although 0.15mm is preferred for conditions where considerable amount of ash is likely to be carried in the sewage. The specific gravity of the grit may be as low as 2.4 but for design purposes a value of 2.65 is used. The settling velocity of discrete particles can be determined using the appropriate equation depending upon the Reynolds number.

a) *Stoke's Law*

$$v_s = \frac{g (\rho_s - \rho) d^2}{18 \rho \nu} \quad (11.4)$$

or

$$= \frac{g}{18} (S_s - 1) \frac{d^2}{\nu}$$

where v_s = settling velocity, m/s

g = acceleration due to gravity, m/s^2

ρ_s = mass density of grit particle, kg/m^3

ρ = mass density of liquid, kg/m^3

S_s = specific gravity of grit particle, dimensionless

d = size of the particle, m

ν = kinematic viscosity of sewage, m^2/s

Stoke's law holds good for Reynolds number R , below 1.0.

$$(R = v_s d / \nu)$$

For grit particles of specific gravity of 2.65 and liquid temperature at 10 degree

$$(\nu = 1.01 \times 10^{-6} \text{ m}^2/\text{s})$$

this corresponds to particles of size less than 0.1 mm. The flow conditions are laminar where viscous forces dominate over inertial forces.

b) Transition Law

The design of grit chamber is based on removal of grit particles with minimum size of 0.2mm or 0.15mm and therefore Stoke's Law is not applicable to determine the settling velocity of the grit particles for design purposes.

The settling velocity of a discrete particle is given by the general equation

$$v_s = \sqrt{\frac{4 g (\rho_s - \rho)}{3 C_D \rho}} d \quad (11.5)$$

Where C_D is the Newton coefficient of Drag which is a function of Reynolds number. The transition flow conditions hold when Reynolds number is between 1 and 1000. In this range, C_D can be approximated by

$$C_D = \frac{18.5}{R^{0.6}} = \frac{18.5}{\left(\frac{v_s d}{\nu}\right)^{0.6}} \quad (11.6)$$

Substituting the value of C_D in equation (11.5) and simplifying

$$V_s = [0.707 (S_s - 1) d^{1.6} \nu^{-0.6}]^{0.714} \quad (11.7)$$

The settling velocity of grit particles in the transition zone is also calculated by the Hazen's modified formula

$$v_s = 60.6 (S_s - 1) d^{\frac{3T+70}{100}} \quad (11.8)$$

where d in equation (11.8) is in cm and T is the temperature in degree, C and

v_s in cm/s.

The settling velocity of grit particles in the range of 0.1mm and 1mm can be determined using equation (11.7) and this equation or its approximate empirical form of Eq. (11.8) should be used in design of grit chambers which are designed to remove particles of size 0.15 mm or 0.2 mm.

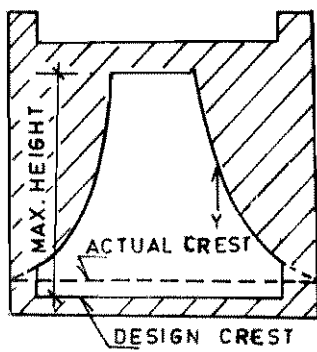

FIG.11.1(a): PROPORTIONAL FLOW WEIR

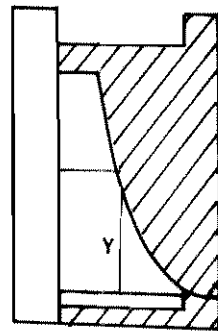

FIG. 11.1 (b): SUTRO WEIR

c) **Newton's Law**

When the particle size increases beyond 1 mm and Reynolds number beyond 1000, the Newton coefficient drag C_D assumes a constant value of 0.4 and the following equation can be used to determine the settling velocity of grit particles.

$$v_s = [3.3 g (S_s - 1) \cdot d]^{0.5} \quad (11.9)$$

11.2.5.2 SURFACE OVER FLOW RATE

Efficiency of an ideal settling basin is expressed as the ratio of the settling velocity of the particles to be removed (v_s) to the surface overflow rate (v_o).

$$\eta = \frac{V_s}{V_o}$$

Where v_o is defined as the ratio of flow of sewage to be treated in an ideal settling tank to the plan area of the tank i.e. Q/A . It is equal to the settling velocity of those particles which will be 100% removed in ideal settling tank.

In an ideal settling basin, all particles having settling velocity, $v_s \geq v_o$ are completely removed. However, particles having settling velocity, $v_s < v_o$ are removed in proportion to the ratio of v_s to v_o .

Table 11.1 gives settling velocity of different size particles of specific gravity 2.65 (inorganic grit particles) and 1.20 (organic matter) and corresponding surface overflow rates for 100% removal of these particles based on Eq.(11.7).

TABLE 11.1
SETTLING VELOCITIES AND SURFACE OVERFLOW
RATES FOR IDEAL GRIT CHAMBER AT 10 DEGREE C.

Diameter of Particles, mm	Settling velocity m/s.		Surface Overflow rate $m^3 / d m^2$	
	$S_s = 2.65$	$S_s = 1.20$	$S_s = 2.65$	$S_s = 1.20$
0.20	0.025	0.0054	2160	467
0.15	0.018	0.0039	1555	337

However, the behaviour of a real grit chamber departs significantly from that of the ideal settling basin due to turbulence and short-circuiting resulting from eddy, wind and density currents. Hence, the surface overflow rates (SOR) should be diminished to account for the basin performance. Following equation could be used to determine the SOR for a real basin for a given efficiency of grit removal and basin performance.

$$\eta = 1 - [1 - n \cdot v_s / (Q/A)]^{\frac{1}{n}} \quad (11.11)$$

where η = desired efficiency of removal of grit particle

v_s = settling velocity of minimum size of grit particle to be removed

QA = design surface overflow rate applicable for grit chamber to be designed

n = an index which is a measure of the basin performance

The values of n are 1/8, 1/4, 1/2 and 1 for very good, good, poor and very poor performance. It can be seen that the design surface overflow rate will be 66.67%, 58.8%, 50% and 33.3% of the settling velocity of the grit particles to be removed to achieve 75% removal efficiency in grit chamber with very good, good and very poor tank performance respectively. In practice, values of two thirds to one half are used in design depending upon the type of the grit chamber. These values are much higher than those needed for organic solids of specific gravity 1.2.

11.2.5.3 DETENTION PERIOD

A detention period of 60 sec is usually adopted.

11.2.5.4 BOTTOM SCOUR AND FLOW THROUGH VELOCITY

Bottom scour is an important factor affecting grit chamber efficiency. The scouring process itself determines the optimum velocity of flow through the unit. This may be explained by the fact that there is a 'critical' velocity of flow ' V_c ' beyond which particles of a certain size and density once settled, may be again placed in motion and reintroduced into the stream of flow. The critical velocity for scour may be calculated from modified Schield's formula:

$$V_c = K_c \sqrt{g(S_s - 1)d} \quad (11.12)$$

Where K_c = 3 to 4.5. A value of 4.0 is usually adopted for grit particles.

For a grit particle size of 0.2mm, the formula gives critical velocity values of 17.1 to 25.6 cm/sec. In actual practice, a horizontal velocity of flow of 15 to 30 cm/sec. is used at peak flows. The horizontal velocity of flow should be maintained constant at other flow rates also to ensure that only organic solids and not the grit are scoured from the bottom. Bottom scour is an important factor particularly affecting the grit chamber efficiency.

11.2.5.5 VELOCITY CONTROL DEVICES

Numerous devices have been designed in an attempt to maintain a constant horizontal velocity of flow through grit chambers in the recommended range of 15 to 30 cm/sec. Since none of the control devices designed so far have been able to maintain the velocity at a constant level at all flows, a limit of variance in the velocity of 5-10% above and below the desired velocity of flow is recommended. Multiple channels with the total capacity to carry the maximum flow and velocity control either manually or by means of side-flow weirs in a distribution box or a diversion channel is sometimes adopted but is not economical. A satisfactory method of controlling velocity of flow through the grit channels is by

using a control section which placed at the end of the channel, varies the cross sectional areas of flow in the section in direct proportion to the flow.

As for example, for a flow of 5 cumecs, the cross-sectional area of flow should be 5 m² and when flow decreases to 3 cumecs the cross-sectional area of flow should be reduced to 3 m² to maintain the velocity of flow constant at 1 mps. Such control sections include Proportional flow weirs, Sutro weirs, Parshall flumes, Palmer flumes etc., of which the former three are commonly used.

a) Proportional Flow Weir

The proportional flow weir is a combination of a weir and an orifice. It maintains a nearly constant velocity in the grit channels by varying the cross-sectional area of flow through the weir so that the depth is proportional to flow (Fig.11.1(a)).

The general equation for determining the flow through weir, Q, is

$$Q = cb \sqrt{2ag} H \cdot \frac{a}{3} \quad (11.13)$$

where c is a coefficient which is assumed 0.61 for symmetrical sharp-edge weirs.

- a = dimension of weir usually assumed between 25mm and 50mm
 b = base width of the weir
 H = depth of flow

To determine the shape of the curve forming the outer edges of the cut portion, the following equation of curve forming the edge of the weir may be used.

$$x = \frac{b}{2} \left(1 - \frac{2}{\pi} \tan^{-1} \sqrt{\frac{Y}{a} - 1} \right) \quad (11.14)$$

The weir shall be set 100mm to 300mm above the bottom of grit chamber to provide grit storage or for operation of mechanical grit chamber. The weir should also be set at such an elevation as to provide a free fall into the outlet channel as it cannot function under submerged conditions. Each grit chamber should be provided with a separate control weir.

b) Sutro Weir

The Sutro-weir is a half proportional flow weir cut symmetrically and centrally along the vertical axis as illustrated in Fig.11.1(b). The orifice has a straight horizontal bottom forming the weir.

c) Parshall Flume

A Parshall flume is an open constricted channel which can be used both as a measuring device and also as a velocity control device, more commonly used for the latter

purpose in grit chambers. The flume has a distinct advantage over the proportional flow weir, as it involves negligible head loss and can work under submerged conditions upto certain limits. The limits of submergence are 50% in case of 150mm throat width and 70% for wider throat widths upto 1 m. Another advantage is that one control section can be installed for 2 to 3 grit

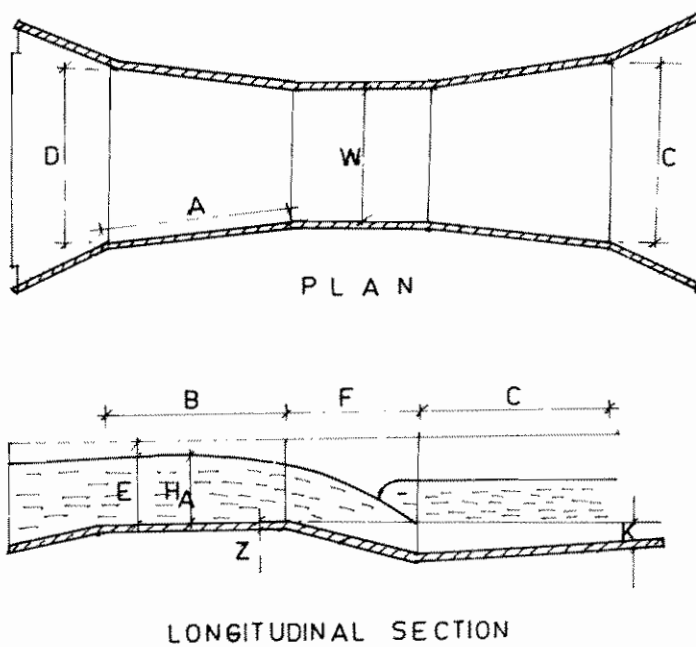

FIG. 11.2: DIMENSIONS FOR PARSHALL FLUME

TABLE 11.2
DIMENSIONS OF PARSHALL FLUME (mm)

†FLOW RANGE Q_{max} (mLd)	W	A	++ B	C	+++D	F	G	K	Z
UP TO 5	75	460	450	175	255	150	300	25	56
5 - 30	150	610	600	315	391	300	600	75	113
30 - 45	225	865	850	375	566	300	750	75	113
45 - 170	300	1350	1322	600	831	600	900	75	225
170 - 250	450	1425	1397	750	1010	600	900	75	225
250 - 350	600	1500	1472	900	1188	600	900	75	225
350 - 500	900	1650	1619	1200	1547	600	900	75	225
500 - 700	1200	1800	1766	1500	1906	600	900	75	225
700 - 850	1500	2100	2060	2100	2625	600	900	75	225
850 - 1400	2400	2400	2353	2700	3344	600	900	75	225

† FOR AVERAGE FLOW AND PEAK FACTORS, SEE 3.2.5

++ VALUE SHOULD BE EQUAL TO $1.5 \times (Q_{max})^{1/3}$ BUT NOT LESS THAN THOSE SHOWN IN THE TABLE

+++ FOR HIGHER VALUES OF B (THAN SHOWN IN THE TABLE), THE VALUES OF D ALSO TO BE INCREASED TO KEEP D/B RATIO SAME AS IN TABLE.

chambers. The flume is also self cleansing and there is no problem of clogging. As the parshall flume is a rectangular control section, the grit chamber above it must be designed to approach a parabolic cross section. However, a rectangular section with a trapezoidal bottom may be used with a parshall flume in which case the variations in velocity at maximum and minimum flow conditions from the designed velocity of flow should be within permissible limits as given by the following equations.

$$Q = 2264W(H_A)^{\frac{3}{2}} \quad (11.15)$$

$$D + Z = 1.1H_A \quad (11.16)$$

and

$$\frac{D_{\min}}{D_{\max}} = \frac{1.1\left(\frac{Q_{\min}}{2264W}\right)^{\frac{2}{3}} - Z}{1.1\left(\frac{Q_{\max}}{2264W}\right)^{\frac{2}{3}} - Z} \quad (11.17)$$

$$D = 1.1\left(\frac{Q}{2264W}\right)^{\frac{2}{3}} - Z \quad (11.18)$$

$$b = \frac{Q_{\max}}{1000D_{\max}V_{\max}} \quad (11.19)$$

or

$$b = \frac{Q_{\min}}{1000D_{\min}V_{\min}} \quad (11.20)$$

$$V = \frac{Q}{1000b.D} \quad (11.21)$$

where

Q = rate of flow in lps

Q min = minimum rate of flow in lps

Q max	=	maximum rate of flow in lps
W	=	throat width in m
H _A	=	depth of flow in upstream leg of the flume at one-third point in m
Z	=	a constant in m
D	=	depth of flow in the grit chamber in m
b	=	width of grit chamber in m and
V	=	velocity of flow in mps at a particular depth of flow

Recommended throat widths for different ranges of flow along with the dimensions of the various elements of the flume (Fig.11.2) for the different throat widths are given in Table 11.2 which should be strictly adhered to.

A typical example is shown in Appendix 11.2.

11.2.5.6 NUMBER OF UNITS

In case of manually cleaned grit chambers at least two units should be provided. All mechanically cleaned units should be provided with a manually cleaned unit to act as a bypass.

11.2.5.7 DIMENSIONS OF EACH UNIT

The surface areas required for each unit is worked out on the basis of the overflow rate chosen as discussed in 11.2.5.2. The breadth of tank is fixed with reference to the control device adopted. The length is then worked out on the basis of the selected overflow rate. In case of mechanised grit chambers, the horizontal dimension may be readjusted to suit the standard sizes of the mechanical equipment after ensuring that the flow-through velocity is within the prescribed limits. The depth of flow is determined by the horizontal velocity and the peak flow. Additional depth for storage of grit between intervals of cleaning should be provided in case of intermittent cleaning. A free board of 150 to 300 mm should be provided. Bottom slopes are based on the type of scraper mechanism used.

11.2.6 Loss of Head

Loss of head in a grit chamber varies from 0.06m to 0.6 m depending on the device adopted for velocity control.

11.2.7 Disposal of Grit

Clean grit is characterised by the lack of odours. Washed grit may resemble particles of sand and gravel, interspersed with particles of egg shell, and other similar relatively inert materials from the households. Grit washing mechanism has to be included whenever the detention time is more and flow through velocity is less. Unless washed, it may contain considerable amount of organic matter. This becomes an attraction to rodents and insects and is also unsightly and odorous. The grit may be disposed of by dumping or burying or by sanitary land fill. The ultimate method used however depends upon the quantity and characteristics of the grit, availability of land for dumping, filling, or burial. In general, unless grit is washed, provision for burial should be made.

SEDIMENTATION

12.1 GENERAL

The purpose of sedimentation of sewage is to separate the settleable solids so that the settled wastewater, if discharged into water courses, does not form sludge banks and when used for land disposal does not lead to clogging of soil pores and excessive organic loading. Primary sedimentation of sewage also reduces the organics load on secondary treatment units. Sedimentation is used in wastewater treatment to remove (i) inorganic suspended solids or grit in grit chamber described in chapter 11 (ii) Organic and residual inorganic solids, free oil and grease and other floating material in plain sedimentation or primary sedimentation tanks which are located after screens and grit chambers (iii) Bio-flocculated solids or bioflocs from effluents of secondary biological treatment units such as trickling filter and activated sludge in secondary settling tanks or secondary clarifiers and (iv) chemical flocs produced during chemical coagulation and flocculation in secondary settling tanks. In addition to primary and secondary settling tanks, intermediate settling tanks are also used to remove the bioflocculated solids in multistage biological treatment units.

Septic tanks, Imhoff tanks and claridigesters are combination units where sedimentation and digestion of settleable solids are combined in single units. Settling also occurs in waste stabilisation ponds and facultative aerated lagoons alongwith organic matter stabilization.

12.2 CHARACTERISTICS OF SETTLEABLE SOLIDS

The settleable solids to be removed from wastewater in primary or secondary settling tanks after grit removal are mainly organic and flocculent in nature, either dispersed or flocculated. The specific gravity of organic suspended solids, may vary from 1.01 to 1.20. The bulk of the finely divided organic solids reaching primary sedimentation tanks are low specific gravity solids which are incompletely flocculated but are susceptible to flocculation. Flocculation occurs within primary settling tanks due to eddying motion of the fluid and aggregation of dispersed flocculent solids becomes more complete as the wastewater is detained for longer periods (hydraulic residence time) in these tanks. Since the particles are subject to flocculation, such settling tanks cannot be designed on the basis of surface overflow rate alone but will have to take into consideration hydraulic residence time or detention period also. However, rate of flocculation rapidly decreases as detention period is increased beyond certain values.

12.3 TYPES OF SETTLING

Basically, four categories of settling occur depending on the tendency of particles to interact and the concentration of solids. These settling types are (i) Discrete settling (ii) Flocculent settling (iii) Hindered or zone settling and (iv) Compression.

12.3.1 Discrete Settling

Discrete particles do not change their size, shape or mass during settling. Grit in wastewater behave like discrete particles. The settling velocity of discrete particles is determinable using Stokes or Transition law. Organic solids in raw wastewater and bioflocs in biologically treated wastewaters cannot be considered as discrete particles and hence Stoke's law is not applicable for these particles.

12.3.2 Flocculent Settling

Flocculent particles coalesce during settling increasing the mass of particles which settle faster. Flocculent settling refers to settling of flocculent particles of low concentration usually less than 1000 mg/l. The degree of flocculation depends on the contact opportunities which in turn are affected by the surface overflow rate, the depth of the basin, the concentration of the particles, the range of particle sizes and the velocity gradients in the system. No adequate mathematical equation exists to describe flocculent settling and therefore overflow rates to achieve a given removal efficiency are determined using data obtained from settling column studies.

The removal of raw sewage organic suspended solids in primary settling tanks, settling of chemical flocs in settling tanks and of bioflocs in the upper portion of secondary sedimentation tanks are examples of flocculent settling.

12.3.3 Hindered or Zone Settling

When concentration of flocculent particles is in intermediate range, they are close enough together so that their velocity fields overlap causing hindered settling. The settling of particles results in significant upward displacement of water. The particles maintain their relative positions with respect to each other and the whole mass of particles settles as a unit or zone. This type of settling is applicable to concentrated suspensions such as are found in secondary settling basins following activated sludge units. In the hindered settling zone, the concentration of particles increases from top to bottom leading to thickening of sludge. Such secondary clarifiers where zone settling occurs are designed on the basis of solid flux or solids loading and checked for surface overflow rate, both of which can be determined by conducting settling column analysis.

12.3.4 Compression

In compression zone, the concentration of particles becomes so high that particles are in physical contact with each other, the lower layers supporting the weight of upper layers. Consequently any further 'settling' results due to compression of the whole structure of particles and accompanied by squeezing out of water from the pores between the solid particles. This settling phenomenon occurs at the bottom of deep sludge mass, such as in the bottom of secondary settling tanks following secondary biological treatment by trickling filters and activated sludge process and in tanks used for thickening of sludge.

12.4 DESIGN CONSIDERATIONS

12.4.1 Factors Influencing Design

Several factors such as flow variations, density currents, solids concentration, solids loading, area, detention time and overflow rate influence the design and performance of sedimentation tanks. In the design of some plants, only a few of these factors may have significant effect on performance while in others, all of them may play an important role. Sedimentation tanks are designed for average flow conditions. Hence during peak flow periods, the detention period gets reduced with increase in the overflow rate and consequent overloading for a short period. If hourly flow variations are wide as in the case of some industrial waste flows, it may be necessary to build an equalization tank, ahead of the treatment units so that uniform loading is made possible in all treatment units.

12.4.2 Design Criteria

For primary sedimentation tanks, both, surface overflow rate and detention period (Hydraulic Residence Time) are important design criteria as the solids to be settled are flocculent in nature and undergo flocculation. The major design parameters for secondary settling tanks designed to remove bioflocculated solids are solids loading rate or solid flux as well as surface overflow rate. The plan surface area of secondary settling tanks is determined using both criteria and the greater of the two is

adopted for design. In addition, other design parameters are depth, displacement velocity (horizontal velocity of flow) and weir loading rate. The design of sludge removal arrangements and inlet and outlet should be done in accordance with the criteria prescribed in subsequent sections for satisfactory performance of any settling tank. Typical values for design parameters of settling tanks are given in Table 12.1.

12.4.2.1 OVERFLOW RATE OR SURFACE LOADING RATE

The overflow rate represents the hydraulic loading per unit surface area of tank in unit time expressed as $m^3/d/m^2$. Overflow rates must be checked both at average plant flows and peak flow. The overflow rates to be adopted for the different settling tanks are given in Table 12.1. The smaller values in the ranges given are applicable to small plants of capacities less than 5 MLD.

**TABLE 12.1
DESIGN PARAMETERS FOR SETTLING TANKS**

Type of Settling	Overflow rate, $m^3/m^2 \cdot d$		Solid loading, $kg/m^2 \cdot d$		Depth, m	Detention Time, hr
	Average	Peak	Average	Peak		
A PRIMARY SETTLING						
1) Primary Settling only	15 - 30	50 - 60			2.5 - 3.5	2.0 - 2.5
2) Primary settling followed by secondary treatment	15 - 50	60 - 120			2.5 - 3.5	·
3) Primary settling with activated sludge return	25 - 35	50 - 60			3.5 - 4.5	·
B SECONDARY SETTLING						
4) Secondary settling for trickling filter	15 - 25	40 - 50	70 - 120	190	2.5 - 3.5	1.5 - 2.0
5) Secondary settling for activated sludge (excluding extended aeration)	15 - 35	40 - 50	70 - 140	210	3.5 - 4.5	·
6) Secondary settling for extended aeration	8 - 15	25 - 35	25 - 120	170	3.5 - 4.5	·

12.4.2.2 DETENTION PERIOD

The rate of removal of BOD and SS is maximum during the first 2 to 2½ hours of settling and thereafter decreases appreciably. Hence, increase in the detention time beyond 2 to 2½ hours will not increase the percentage removal of BOD or SS proportionately. Longer detention period may affect the tank performance adversely due to setting in of septic conditions, particularly in tropical climates. Experience has shown that a detention period of 2 to 2½ hours for primary settling tanks and 1½ to 2 hours for secondary settling tanks will produce the optimum results.

Longer detention periods in secondary settling tanks may result in denitrification which adversely affects the settling efficiency.

12.4.2.3 SOLIDS LOADING RATE

The solids loading rate or solid flux is an important decision variable for the design of secondary sedimentation tank receiving bioflocculated solids. The solid flux represents the solids loading per unit surface area of tank per unit time and is expressed as $kg \text{ SS}/m^2 \cdot d$. Design solid loadings at average and peak flows are presented in Table 12.1

12.4.2.4 WEIR LOADING

Weir loading influences the removal of solids in sedimentation tank, particularly in secondary settling tanks where flocculated solids are settled. There is no positive evidence that weir loading has any significant effect on removal of solids in primary settling tanks. However, certain loading rates based on practice are recommended both for primary as well as secondary tanks. For all primary, intermediate and secondary settling tanks, except in the case of secondary tanks for activated sludge process, weir loading of the order of $125 \text{ m}^3/\text{d.m.}$ for average flows is recommended. For secondary settling tanks in activated sludge or its modifications, the weir loading is around $185 \text{ m}^3/\text{d.m.}$ The loading should however ensure uniform withdrawal over the entire periphery of the tank to avoid short circuiting or dead pockets. Performance of existing sedimentation tanks can be improved by merely increasing their weir length.

This restriction in weir overflow rate requires special outlet weir design including a total weir length several times the tank width, for rectangular tanks and often two weirs with an outlet channel between them for circular tanks. Very long weirs cannot be maintained truly level over their full length, except perhaps at considerable expense; and satisfactory distribution of flow is more readily obtained by forming indentations at regular intervals such as shallow-V-notches say 50mm deep spaced 0.15 to 0.3 m apart. In addition to the head above the V-notches, a reasonable free fall of 0.05 to 0.15m should be allowed for maximum flows depending in part, on the total head available.

12.4.2.5 DEPTH

The depth sets the detention time in the settling tank and also influences sludge thickening in secondary settling tanks of activated sludge plants. The depth recommended for horizontal flow tanks are given in Table 12.1. In vertical flow tanks, depth may be 2.0m excluding hoppers.

12.4.2.6 SLUDGE REMOVAL

Sludge can be removed manually, hydrostatically or mechanically from the sedimentation tanks. Mechanical cleaning of sludge should be preferred to manual cleaning even in small plants, where power is available for running the plant machinery. Even where power is not available or inadequate or exorbitantly costly, hydrostatic removal should be adopted to avoid manual handling of sludge to prevent exposure of workers to health hazards.

Manual removal requires the tank to be put out of commission for dewatering. Sludge is then flushed by a jet of water into sumps. Workers may also have to enter tank and push the sludge into sumps by means of brushes and squeegees. The sludge collected in the sumps is withdrawn from the tank by gravity, hydrostatic pressure or pumping. The slope of the tank floors should be gentle, not more than 1 to 2 percent, towards the sump for men to walk on the floor. Tank capacity should also provide for storage of sludge between intervals of cleaning not exceeding 7 days in tropical climates. Manual cleaning has been largely given up in favour of mechanical cleaning in modern practice.

Tanks are provided with hopper bottoms for hydrostatic sludge removal. Generally horizontal flow tanks are provided with rectangular hoppers and vertical tanks with circular or square types. Side slopes of the hoppers should be of the order of 1.2:1 to 2:1 preferably with values greater than 1.7:1 and 1.5:1 for pyramidal and conical hoppers respectively. The floor of the hoppers should not be wider than 0.6 m.

Mechanical sludge scraping is best suited for circular or square tanks and occasionally adopted in rectangular tanks. The scrapers or ploughs push the sludge along the tank bottom to sludge collecting channel or pocket from where it is either pumped directly or gravitated to a sludge sump for further disposal.

In rectangular tanks, sludge hoppers are generally placed at the inlet end. But they may be placed at mid-length in long tanks or at the outlet end in case of secondary settling tank of activated

sludge plant. The sludge scraping mechanism may be of a moving bridge type of flight scrapers mounted on endless chain conveyors. The linear conveyor speed should not exceed 0.010 to 0.015 mps. In case of flight scrapers, the maximum width of tanks is greater than twice the depth. Multiple flight scrapers are placed side by side, in which case the width of tank could be increased upto a maximum 30 m. When multiple flight scrapers are used, the receiving sludge hoppers is designed as a trough with transverse collectors to convey the sludge to a single outlet pocket. A bottom slope of 1% is recommended for mechanical scraping of sludge.

The most common type of sludge scraping in circular or square tanks consists of a revolving mechanism with radial arms having ploughs or blades set at an angle just above floor level. The ploughs push the sludge to a central hopper as the arms are rotated. Sludge from the central hopper is removed to a sludge sump by the side of the tank from where it is pumped. For small dia. upto 9m the revolving bridge is spanned across the tank dia while for larger sizes it is supported on the tank wall on one side and on a hollow pillar at the centre of the tank on the other side which also serves as an inlet. Drive motors can be either stationary or movable in the case of traction drive and are placed above the tank.

The rotating mechanism of the sludge scraper for square tanks is similar to that of circular tanks except for additional pivoted corner blades for removing sludges from the corners. All rotary mechanisms are operated at a low speed of 1 to 2 rph.

The interval between sludge removal should be preferably less than 4 hours and never exceed 12 hours. Light flocculent sludges such as the activated sludge or mixture of activated sludge and primary sludge are scraped and removed continuously from the tank to avoid septicity. The peripheral speed of the scraper should be between 2.5 to 4 cm/sec.

Where sludge is removed intermittently with intervals longer than 4 hrs, provision for sludge storage in the hoppers should be made. Sludge conveyor pipes should not be less than 200 mm in dia. Hopper volumes should be excluded from the effective sedimentation volume of the tank.

12.4.2.7 INLETS AND OUTLETS

Performance of sedimentation tanks is very much influenced by inlet devices which are intended to distribute and draw the flow evenly across the basin. All inlets must be designed to keep down the entrance velocity to prevent formation of eddy or inertial currents in the tank to avoid short circuiting. Design should ensure least interference with the settling zone to promote ideal settling conditions. Choice of inlet and outlet design depends on the geometry of sedimentation tank and the mode of entry and exit from the tank.

In horizontal flow rectangular tanks, inlets and outlets are placed opposite each other separated by the length of tank with the inlet perpendicular to the direction of flow.

In the design of inlets to rectangular tanks the following methods are used to distribute the flow uniformly across the tank:

- (a) Multiple pipe inlets with baffle boards of depth 0.45 to 0.6m in front of the inlets, 0.6 to 0.9 m away from it, and with the top of baffle being 25mm below water surface for the scum to pass over
- (b) channel inlet with perforated baffle side wall between the tank and the channels, or
- (c) inlet channel with submerged weirs discharging into tank followed by a baffle board inside the tank.

A stilling chamber is necessary ahead of inlets if the sewage is received under pressure from pumping mains.

Outlet is generally an overflow weir located near the effluent end, preferably adjustable for maintaining the weir at a constant level. V-notches are provided on the weir to provide for uniform distribution of flow at low heads of discharge over the weir. Weir lengths could be increased by placing outlet channel inside the tank with weirs on both sides. Scum baffles are provided ahead of outlet devices to prevent the escape of scum with the effluent.

In radial flow circular tanks the usual practice is to provide a central inlet and a peripheral outlet. The central inlet pipe may be either a submerged horizontal pipe from wall to centre or an inverted siphon laid beneath the tank floor. An inlet baffle is placed concentric to the pipe mouth generally with a diameter of 10-20% of the tank diameter and extending 1 to 2 m below water surface. Where the inlet pipe discharges into a central hollow pillar, the top of the pillar is flared to provide adequate number of inlet diffusion ports through which sewage enters the tank with an entry velocity of 0.10 to 0.25 mps through the ports. The entry ports are submerged 0.3 to 0.6 m below water surface.

The outlet is generally a peripheral weir discharging freely into a peripheral channel. The crest of the weir is provided with V-notches for uniform draw off at low flows. In all primary settling tanks a peripheral scum baffle extending 0.20 to 0.30 m below water surface is provided ahead of effluent weir. If the length of the peripheral weir is not adequate, a weir trough mounted on wall brackets near the periphery with adjustable overflow weir on both sides is provided to increase the length of weir.

12.4.2.8 SCUM REMOVAL

One distinct feature of primary settling tank is the skimming device which, though desirable is not normally provided in intermediate or secondary settling tanks. The skimming device could be operated by the same scraper mechanism used for sludge scraping at the bottom of the tank. It generally consists of a skimmer arm to which a scraper blade is attached and moved, partly submerged and partly projecting above the water surface, from the outlet end towards the inlet end in case of rectangular tanks or in a circular path in the case of circular tanks. The floating scum is thus collected at the forward end of the scraper blade and moved till it is tripped manually or automatically into a scum trough which discharges the scum to a sump outside the tank from where it is removed for burial, burning or feeding to the digester. A scum baffle at least 0.15 m above and extending to at least 0.30m below water level is provided along the periphery, ahead of outlet device, to prevent the escape of scum with effluent.

12.4.2.9 TYPES AND SHAPES

Circular tanks are more common than rectangular or square tanks. Upflow tanks have been used for sewage sedimentation but horizontal flow types are more popular. Rectangular tanks need less space than circular tanks and could be more economically designed where multiple units are to be constructed in a large plant. They can form a more compact layout with the rectangular secondary treatment units such as aeration tanks in the activated sludge system.

For rectangular tanks, maximum length and widths of 90 and 30m respectively with length to width ratios of 1.5 to 7.5 and length to depth ratios of 5 to 25 are recommended. A minimum depth of 2.5 m in case of primary settling tanks and 3.5 m in case of secondary settling tanks for activated sludge should be provided. Bottom slopes of 1% are normally adopted. Peak velocities greater than 1.5 mph should be avoided.

Diameters of circular tanks vary widely from 3 to 60 m although the most common range is 12 to 30m. Diameters and depths could be chosen at the discretion of the designer in conformity with the manufactured sizes of scraper mechanisms in the country. The water depth varies from 2m for primary to 3.5m for secondary settling tanks. Floors are sloped from periphery to centre at a rate of 7.5 to 10%. The inlet to the tank is generally at the centre and outlet is a peripheral weir, the flow being radial and horizontal from centre to the periphery of the tank. Multiple units are arranged in pairs with feed from a central control chamber.

12.5 PERFORMANCE

Primary sedimentation of domestic sewage may be expected to accomplish 30 to 45% removal of BOD and 45 to 60% removal of SS depending on concentration and characteristics of solids in suspension. Secondary settling tanks, if considered independently, remove a very high percentage of flocculated solids, even more than 99%, particularly following an activated sludge unit where a high mixed liquor suspended solids concentration is maintained in the aeration chamber. However, the efficiency of the biological treatment process is always defined in terms of the combined efficiency of the biological treatment units and its secondary settling tank with reference to the characteristics of the incoming sewage.

12.6 CHEMICAL-AIDED SEDIMENTATION

Chemical-aided sedimentation of sewage or industrial wastewater is analogous to chemical coagulation, flocculation and sedimentation in water treatment. The colloidal and finely dispersed solids which cannot be removed by plain primary sedimentation alone as they possess extremely low settling velocities are aggregated into settleable particles by addition of chemicals in chemical-aided sedimentation. Commonly used chemicals are trivalent or divalent metallic salts such as aluminium sulphate, ferric and ferrous salts and lime. Polyelectrolytes and polymers; cationic, anionic and nonionic, have also been used both as primary coagulants as well as coagulant-aids. The colloidal particles in domestic wastewaters are usually negatively charged and therefore do not agglomerate naturally into settleable mass. Addition of chemical coagulants results in destabilisation, aggregation and binding together by any one or more than one mechanisms of (i) Ionic Layer compression (ii) Adsorption and Charge Neutralisation (iii) Enmeshment in Precipitate and (iv) Interparticle Bridging. When Aluminium and Iron Salts are added to wastewaters in quantities sufficient to exceed the solubility limits of metal hydroxide, polymers of hydroxometal [e.g. $Al_3(OH)_4^{3+}$] complexes are formed which are adsorbed on colloidal particles and neutralise their charge or form bridging between colloidal particles if the polymers are of the same charge as that on colloidal particles. Further, colloidal particles can get entrapped within the metal hydroxide precipitates which are heavy and settleable. Chemically-aided sedimentation produces intermediate results between plain sedimentation and secondary biological treatment. With proper dosages of chemicals, this treatment process may be expected to remove 60 to 80% of suspended solids and 45 to 65% of BOD when it is not preceded by any plain sedimentation.

Chemical-aided sedimentation involves the unit processes and operations of chemical coagulation, flocculation and sedimentation. Therefore, it will not remove dissolved solids. On the contrary, addition of chemicals which are soluble may add to the total dissolved solids concentration of wastewater.

As compared to secondary biological treatment methods such as trickling filter or activated sludge, chemical treatment methods will be less efficient and will work out to be uneconomical and are therefore recommended only when

- i) Plants are operated seasonally or variations in strength and volume of sewage are high
- ii) intermediate treatment between plain sedimentation and secondary biological treatment is adequate
- iii) sludge conditioning for dewatering is needed.

12.6.1 Chemicals Used

The most commonly used chemicals are ferrous sulphate; ferric chloride, ferric sulphate, chlorinated copperas, alum, aluminium chloride, lime and sodium carbonate. Choice of chemical and its dosage depend on cost of chemical, degree of treatment required and the characteristics of the

waste, pH being one of the more important factors. Optimum dosage is determined by conducting Jar Test in the laboratory.

12.6.1.1 IRON SALTS

Ferric salts are better coagulants than ferrous salts because of their higher valency and their efficiency over a wider pH range. Ferric salts are effective at approximate pH values above 3, the efficiency increasing with increase in pH, while the useful pH range of ferrous salts is above 10. But when waste waters are highly alkaline due to presence of trade wastes, it may be cheaper to use larger dosage of ferrous salts as they are relatively cheaper. Chlorinated copperas which is an equimolar mixture of ferric sulphate and ferric chloride formed by the addition of chlorine to ferrous sulphate is also used in place of ferric salts.

12.6.1.2 ALUMINIUM SALTS

Aluminium chloride and sulphate of alumina (filter alum) are the commonly used aluminium salts. Where alum is used, the sludge produced is greater in volume and also bulky than with iron salts making it less easily settleable.

12.6.1.3 LIME AND SODIUM CARBONATE

These are used for pH adjustment to favourable ranges of coagulants especially when sewage is highly acidic. Lime is sometimes used independently as precipitant, particularly when iron pickling liquors are present in sewage. The action may be due to formation of calcium carbonate floc or reactions with small amounts of aluminium or iron salts present in sewage. Lime incidentally helps in grit separation, oil and grease removal and is perhaps the cheapest chemical used in chemical precipitation.

12.6.2 Unit Operations

The process consists of the three unit operations viz., proportioning and mixing of chemicals, flocculation and sedimentation.

12.6.2.1 MIXING

The required dose of chemical is weighed and fed to sewage by means of proportioning and feeding devices, ahead of the mixing unit. Mixing is accomplished in a rapid or flash mixing unit provided with paddles, propellers or by diffused air and having detention period of 0.5 to 3 minutes. The paddles or propellers are mounted on a vertical shaft and driven by a constant speed motor through reduction gears. The size and speed of the propeller is so selected as to give a propeller capacity of twice the maximum flow through the tank. The shaft speed is generally of the order of 100 - 120 rpm and power requirement is about 0.1 kw/mLd.

12.6.2.2 FLOCCULATION

The principle of flocculation in sewage is similar to flocculation in water purification. The flocs that are formed after flash mixing with chemicals are made to coalesce into bigger sizes by either air flocculation or mechanical flocculation. Both diffused air and mechanical vertical draft tube are used for air flocculation. Revolving paddle type is the most common of the mechanical flocculators. The tanks are usually in duplicate with a detention period of 30-90 minutes depending upon results required and the type of sewage treated. However, the dose of chemical required as well as the flocculation period are best determined by laboratory test followed by pilot plant studies for optimum results. The paddles are mounted either on a horizontal or vertical shaft. The peripheral speed of the paddles is kept in the range of 0.3 to 0.45 mps. The flow-through velocity through the flocculator should be in the range of 15 to 25 cm/sec to prevent sedimentation.

In case of domestic sewage and certain industrial wastes, mechanical flocculation without addition of chemicals will induce self-flocculation of the finely divided suspended solids and hence increase the efficiency of sedimentation

12.6.2.3 SEDIMENTATION

The flocculated sewage solids are settled out in a subsequent sedimentation tank. The design features of these tanks are similar to secondary settling tanks as discussed in 12.3.2. Usually detention period of 2 hrs and an overflow rate of not more than $50 \text{ m}^3/\text{d.m}^2$ for average flows is adopted in the design of these sedimentation tanks.

CHAPTER 13

AEROBIC SUSPENDED GROWTH SYSTEMS

13.1 INTRODUCTION

Aerobic suspended growth systems are of two basic types, those which employ sludge recirculation, viz., conventional activated sludge process and its modifications and those which do not have sludge recycle, viz., aerated lagoons. In both cases sewage containing waste organic matter is aerated in an aeration basin in which micro-organisms metabolize the soluble and suspended organic matter. Part of the organic matter is synthesized into new cells and part is oxidized to carbon dioxide and water to derive energy. In activated sludge systems the new cells formed in the reaction are removed from the liquid stream in the form of a flocculant sludge in settling tanks. A part of this activated sludge is recycled to the aeration basin and the remaining forms waste or excess sludge. In aerated lagoons the microbial mass leaves with the effluent stream or may settle down in areas of the aeration basin where mixing is not sufficient.

The suspended solids concentration in the aeration tank liquor, also called mixed liquor suspended solids (MLSS), is generally taken as an index of the mass of active micro-organisms in the aeration tank. However, the MLSS will contain not only active micro-organisms but also dead cells as well as inert organic and inorganic matter derived from the influent sewage. The mixed liquor volatile suspended solids (MLVSS) value is also used and is preferable to MLSS as it eliminates the effect of inorganic matter.

Aerobic and facultative bacteria are the predominant micro-organisms which carry out the above reactions of organic matter i.e. oxidation and synthesis. Their cellular mass contains about 12% Nitrogen and 2% Phosphorous. These nutrients should be present in sufficient quantity in the waste or they may be added, required, for the reactions to proceed satisfactorily. A generally recommended ratio of $BOD_5:N:P$ is 100:5:1. Domestic wastewater is generally balanced with respect to these nutrients.

13.2 ACTIVATED SLUDGE PROCESS VARIABLES

An activated sludge plant essentially consists of the following: (i) Aeration tank containing microorganisms in suspension in which the reaction takes place, (ii) Activated sludge recirculation system, (iii) Excess sludge wasting and disposal facilities, (iv) Aeration systems to transfer oxygen and (v) Secondary sedimentation tank to separate and thicken activated sludge. These are schematically illustrated in Fig.13.1 (a) to (e).

The main variables of the activated sludge process are the loading rate, the mixing regime and the flow scheme.

13.2.1 Loading Rate

The loading rate expresses the rate at which the sewage is applied in the aeration tank. A loading parameter that has been developed empirically over the years is the hydraulic retention time (HRT), θ , d

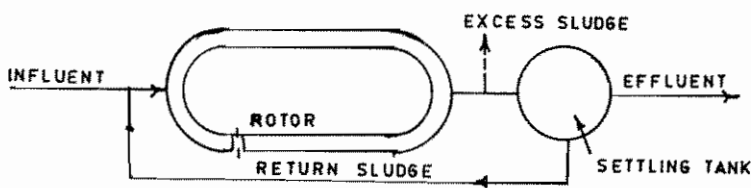
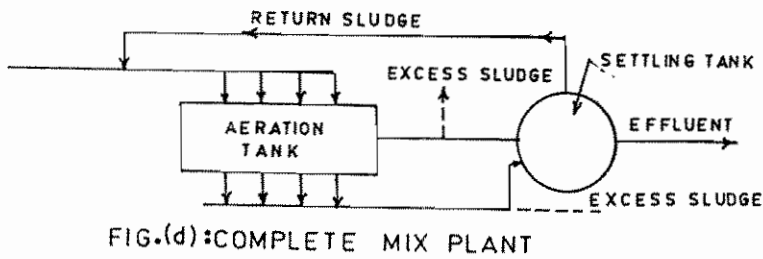
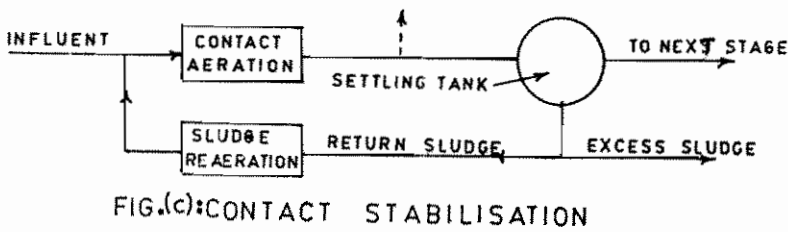
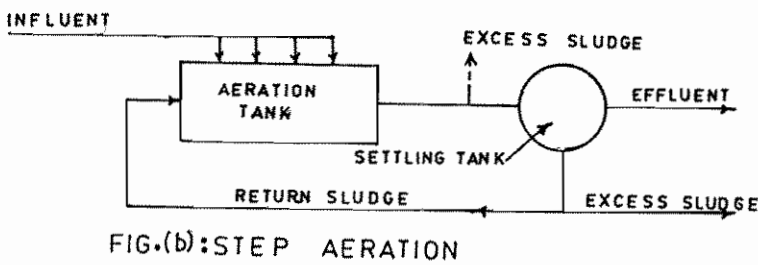
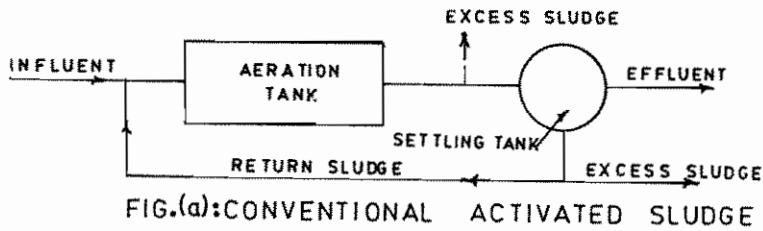

FIG.13.1: SCHEMATIC DIAGRAMS OF ACTIVATED SLUDGE TREATMENT WITH DIFFERENT MODIFICATIONS.

$$\theta = \frac{V}{Q} \quad (13.1)$$

Where

V = volume of aeration tank, m^3 , and

Q = sewage inflow, m^3/d

Another empirical loading parameter is volumetric organic loading which is defined as the BOD applied per unit volume of aeration tank, per day.

A rational loading parameter which has found wider acceptance and is preferred, is specific substrate utilization rate, U , per day which is defined as:

$$U = \frac{Q (S_0 - S)}{V X} \quad (13.2)$$

A similar loading parameter is mean cell residence time or sludge retention time (SRT), θ_c , day:

$$\theta_c = \frac{VX}{Q_w X_s} \quad (13.3)$$

Where S_0 and S are influent and effluent organic matter concentrations respectively, conventionally measured as BOD_5 , (g/m^3) X and X_s are MLSS concentration in aeration tank and waste activated sludge from secondary settling tank under flow, respectively, (g/m^3) and Q_w = waste activated sludge rate, (m^3/d).

Under steady state operation the mass of waste activated sludge is given by

$$Q_w X_s = YQ (S_0 - S) - k_d X V \quad (13.4)$$

Where Y = maximum yield coefficient (microbial mass synthesized/mass of substrate utilised) and k_d = endogenous respiration rate constant, (d^{-1}).

From the above equations it is seen that

$$1 / \theta_c = YU - k_d \quad (13.5)$$

Since both Y and k_d are constants for a given waste, it is, therefore, necessary to define either θ_c or U . Eq. (13.5) is plotted in Fig.13.2 for typical values of $Y = 0.5$

and $k_d = 0.06/d$ for municipal wastewaters.

If the value of S is small compared to S_0 , which is often the case for activated sludge systems treating municipal wastewater, U may also be expressed as Food applied to Microorganism ratio, F/M :

$$F / M = \quad QS_0 / XV \quad (13.6)$$

The Θ_c value adopted for design controls the effluent quality, and settleability and drainability of biomass. Other operational parameters which are affected by the choice of Θ_c values are oxygen requirement and quantity of waste activated sludge. Figure 13.3 gives Θ_c value as a function of temperature for 90-95% reduction of BOD of municipal wastewaters. Typical values of loading parameters for various activated sludge modifications commonly used in India are furnished in Table 13.1.

13.2.2 Mixing Regime

The mixing regime employed in the aeration tank may be plug flow or completely mixed flow. Plug-flow implies that the sewage moves down progressively along the aeration tank essentially unmixed with the rest of the tank contents. Completely mixed flow involves rapid dispersal of the incoming sewage throughout the tank. In the plug flow system, the F/M and the oxygen demand will be highest at the inlet end of the aeration tank and will then progressively decrease. In the completely mixed system, the F/M and the oxygen demand will be uniform throughout the tank.

13.2.3 Flow Scheme

The flow scheme involves the pattern of sewage addition and sludge return to the aeration tank and also the pattern of aeration. Sewage addition may be at a single point at the inlet end of the tank or it may be at several points along the aeration tank. The sludge return may be directly from the settling tank to the aeration tank or through a sludge reaeration tank. Aeration may be at a uniform rate or it may be varied from the head of the aeration tank to its end.

13.3 CONVENTIONAL SYSTEM AND MODIFICATIONS

The conventional system represents the early development of the activated sludge process. Over the years, several modifications to the conventional system have been developed to meet specific treatment objectives by modifying the process variables discussed in 13.2.

In step aeration, settled sewage is introduced at several points along the tank length which produces a more uniform oxygen demand throughout. Tapered aeration attempts to supply air to match oxygen demand along the length of the tank. Contact stabilization provides for reaeration of return activated sludge from the final clarifier, which allows a smaller aeration or contact tank. While conventional system maintains a plug flow hydraulic regime, completely mixed process aims at instantaneous mixing

of the influent waste and return sludge with the entire contents of the aeration tank. Extended aeration process operates at a low organic load producing lesser quantity of well stabilized sludge. The conventional system and the last two modifications named above have found wider acceptance. These are described below in greater detail.

13.3.1 Conventional System

The Conventional system is always preceded by primary settling. The plant itself consists of an aeration tank, a secondary settling tank, a sludge return line and an excess sludge waste line leading to a digester.

The BOD removal in the process is 85-92 percent. The plant employs a plug flow regime which is achieved by a long and narrow configuration of the aeration tank with length equal to 5 or more times the width. The sewage and mixed liquor are let in at the head of the tank and withdrawn at its end. Because of the plug flow regime, the oxygen demand at the head of the aeration tank is high and then tapers down. However, air is supplied in the process at a uniform rate along the length of the tank. This leads to either oxygen deficiency in the initial zone or wasteful application of air in the subsequent reaches. Another limitation of the plug flow regime is that there is a lack of operational stability at times of excessive variation in rate of inflow and in influent strength. For historical reasons, the conventional system is the most widely used type of the activated sludge process. Plants upto 300 mld capacity have been built in India.

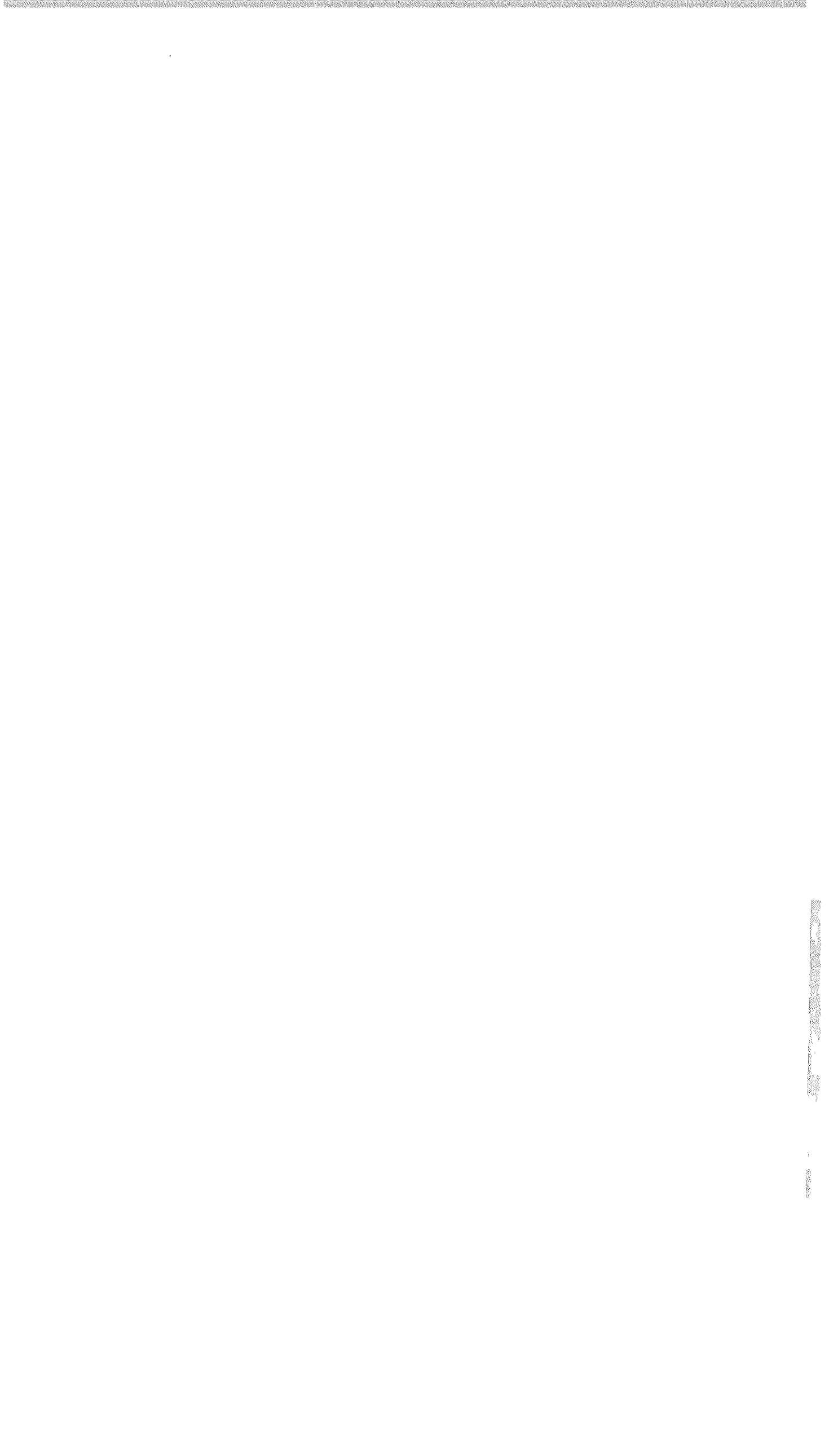

227 (A)

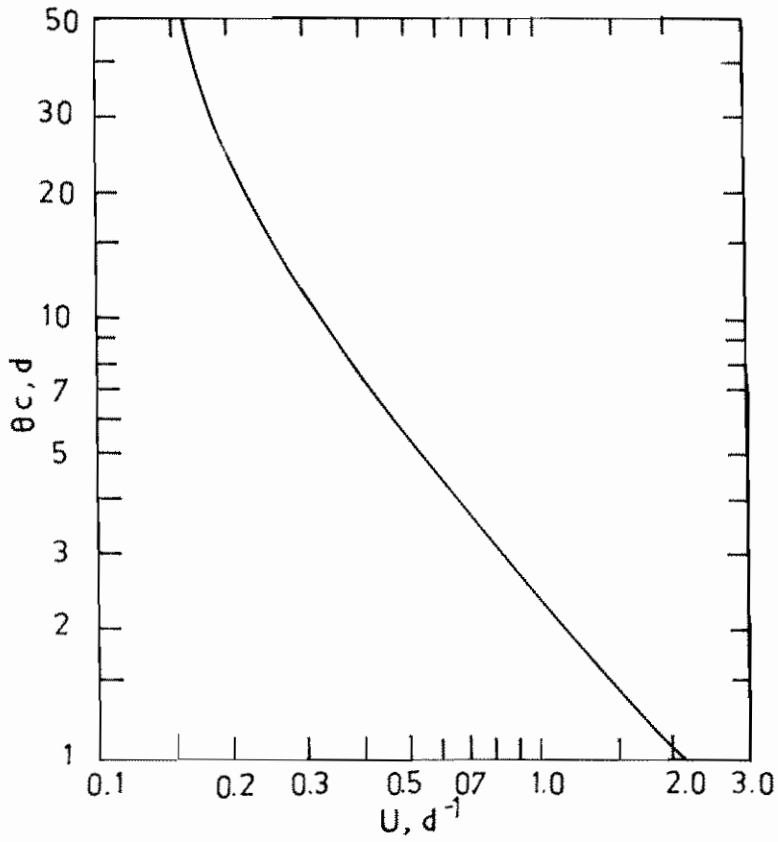

FIG.132: RELATIONSHIP BETWEEN SRT (θ_c) AND SPECIFIC SUBSTRATE UTILIZATION RATE (U) FOR $Y = 0.5$ AND $k = 0.06 d^{-1}$

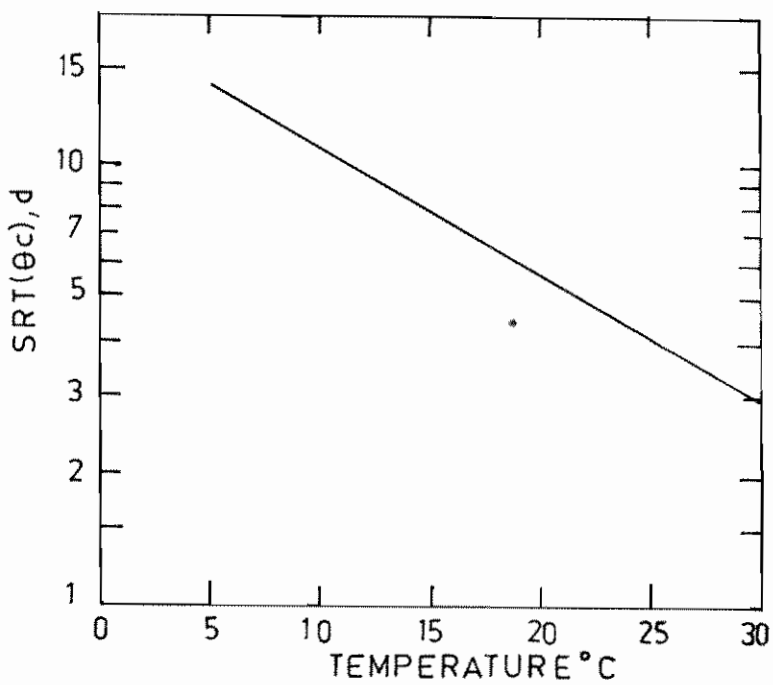

FIG.133: SRT AS A FUNCTION OF AERATION BASIN TEMPERATURE FOR 90-95% BOD REMOVAL

13.3.2 Completely Mixed

The complete mix activated sludge plant employs a completely mixed flow regime. In a rectangular tank, complete mixing is achieved by distributing the sewage and the return sludge uniformly along one side of the tank and withdrawing the aerated sewage uniformly along the opposite side. In a circular or square tank complete mixing is achieved by mechanical aerators with adequate mixing capacity installed at the centre of the tank.

The completely mixed plant has the capacity to hold a high MLSS level in the aeration tank enabling the aeration tank volume to be reduced. The plant has increased operational stability at shock loadings and also increased capacity to treat toxic biodegradable wastes like phenols.

13.3.3 Extended Aeration

The flow scheme of the extended aeration process and its mixing regime are similar to that of the completely mixed process except that primary settling is omitted. The process employs low organic loading, long aeration time, high MLSS concentration and low F/M. The BOD removal efficiency is high. Because of long detention in the aeration tank, the mixed liquor solids undergo considerable endogenous respiration and get well stabilised. The excess sludge does not require separate digestion and can be directly dried on sand beds. Also the excess sludge production is a minimum.

The oxygen requirements for the process is higher and the running costs are also therefore high. However, operation is rendered simple due to the elimination of primary settling and separate sludge digestion. The method is, therefore, well suited specially for small and medium size communities and zones of a larger city.

In small plants intermittent operation of extended aeration systems may be adopted. Intermittent aeration cycles are: (i) closing of inlet and aerating the sewage, (ii) stopping aeration and letting the contents settle and (iii) letting in fresh sewage which displaces an equal quantity of clarified effluent. Sludge is wasted from the mixed liquor. To handle continuous flows a number of units may be operated in parallel.

The oxidation ditch is one form of an extended aeration system having certain special features like an endless ditch for the aeration tank and a rotor for the aeration mechanism. The ditch consists of a long continuous channel usually oval in plan. The channel may be earthen with lined sloping sides and lined floor or it may be built in concrete or brick with vertical walls. The sewage is aerated by a surface rotor placed across the channel. The rotor not only aerates the sewage but also imparts a horizontal velocity to the mixed liquor preventing the biological sludge from settling out.

13.4 DESIGN CONSIDERATION

The items for consideration in the design of activated sludge plant are aeration

tank capacity and dimensions, aeration facilities, secondary sludge settling and recycle and excess sludge wasting.

13.4.1 Aeration Tank

Equations 13.2 to 13.4 can be combined to yield

$$VX = \frac{YQ(S_0 - S)}{1 + k_d \theta_c} \quad (13.7)$$

The volume of the aeration tank is calculated for the selected, value of θ_c by assuming a suitable value of MLSS concentration, X , in Eq. (13.7).

Alternatively the tank capacity may be designed from F/M and MLSS concentration according to Equation 13.6. The F/M and MLSS levels generally employed in different types of commonly used activated sludge systems are given in Table 13.1 along with their corresponding BOD removal efficiencies.

It is seen that economy in reactor volume can be achieved by assuming a large value for X . However, it is seldom taken to be more than 5000 g/m³. A common range is between 1000 and 4000 g/m³. Considerations which govern the upper limit are: initial and running cost of sludge recirculation system to maintain a high value of MLSS, limitations of oxygen transfer equipment to supply oxygen at required rate in a small reactor volume, increased solids loading on secondary clarifier which may necessitate a larger surface area to meet limiting solid flux, design criteria for the tank and minimum HRT for the aeration tank for stable operation under hydraulic surges.

Except in the case of extended aeration plants and completely mixed plants, the aeration tanks are designed as long narrow channels. This configuration is achieved by the provision of round-the-end baffles in small plants when only one or two tank units are proposed and by construction as long and narrow rectangular tanks with common intermediate walls in large plants when several units are proposed. In extended aeration plants other than oxidation ditches and in complete mix plants the tank shape may be circular or square when the plant capacity is small or rectangular with several side inlets and equal number of side outlets, when the plant capacity is large.

The width and depth of the aeration channel depends on the type of aeration equipment employed. The depth controls the aeration efficiency and usually ranges from 3 to 4.5 m, the latter depth being found to be more economical for installations treating more than 50 mld. Beyond 70 mld duplicate units are preferred. The width controls the mixing and is usually kept between 5 and 10 m. Width-depth ratio should be adjusted to be between 1.2 to 2.2. The length should not be less than 30 or not ordinarily longer than 100 m in a single section length before doubling back. The horizontal velocity should be around 1.5 m/min. Excessive width may lead to

settlement of solids in the tank. Triangular baffles and fillets are used to eliminate dead spots and induce spiral flow in the tanks. Tank free-board is generally kept between 0.3 and 0.5 m.

Due consideration must be given in the design of aeration tanks to the need for emptying them for maintenance and repair of the aeration equipment. Intermediate walls should be designed for empty conditions on either side. The method of dewatering should be considered in the design and provided for during construction.

The inlet and outlet channels of the aeration tank should be designed for empty conditions on either side. The method of dewatering should be considered in the design and provided for during construction.

The inlet and outlet channels of the aeration tanks should be designed to maintain a minimum velocity of 0.2 mps to avoid deposition of solids. The channels or conduits and their appurtenances should be sized to carry the maximum hydraulic load to the remaining aeration tank units when any one unit is out of operation.

The inlet should provide for free fall into aeration tank when more than one tank unit or more than one inlet is proposed. The free fall will enable positive control of the flows through the different inlets. Outlets usually consist of free fall weirs. The weir length should be sufficient to maintain a reasonably constant water level in the tank. When multiple inlets or multiple tanks are involved, the inlets should be provided with valves, gates or stop planks to enable regulation of flow through each inlet.

13.4.2 Oxygen Requirements

Oxygen is required in the activated sludge process for the oxidation of a part of the influent organic matter and also for the endogenous respiration of the micro-organisms in the system.

The total oxygen requirement of the process may be formulated as follows:

$$O_2 \text{ required } \frac{g}{d} = \frac{Q S_0 - S}{f} + 1.42 Q_w X_s \quad (13.8)$$

Where

f = ratio of BOD_5 to ultimate BOD and 1.42 = oxygen demand of biomass, g/g.

The formula does not allow for nitrification but allows only for carbonaceous BOD removal. The extra theoretical oxygen requirement for nitrification is 4.56 Kg O_2 /per kg NH_3 -N oxidised to NO_3 -N

The total oxygen requirements per Kg BOD_5 removed for different activated

sludge processes are given in Table 13.1. The amount of oxygen required for a particular process will increase within the range shown in the table as the F/M value decreases.

13.4.3 Aeration Facilities

The aeration facilities of the activated sludge plant are designed to provide the calculated oxygen demand of the waste water against a specific level of dissolved oxygen in the waste water. The aeration devices apart from supplying the required oxygen demand shall also provide adequate mixing or agitation in order that the entire mixed liquor suspended solids present in the aeration tank will be available for the biological activity. The recommended dissolved oxygen concentration in the aeration tank is in the range 0.5 to 1 mg/l for conventional activated sludge plants and in the range 1 to 2 mg/l for extended aeration type activated sludge plants and above 2 mg/l when nitrification is required in the activated sludge plant.

Aerators are rated based on the amount of oxygen they can transfer to tap water under standard conditions of 20° C, 760 mm Hg barometric pressure and zero DO.

The oxygen transfer capacity under field conditions can be calculated from the standard oxygen transfer capacity by the formula:

$$N = \frac{N_s(C_s - C_L) \times 1.024^{T-20} \alpha}{9.17} \quad (13.9)$$

Where

- N = oxygen transferred under field conditions, Kg O₂/hr
- N_s = oxygen transfer capacity under standard conditions, kg O₂/hr
- C_s = dissolved oxygen saturation value for sewage at operating temperature
- C_L = operation DO level in aeration tank usually 1 to 2 mg/l
- T = Temperature, degree C
- α = Correction factor for oxygen transfer for sewage, usually 0.8 to 0.85

Oxygen may be supplied either by surface aerators or diffused air aeration systems employing fine or coarse diffusers. In India surface aerators are the method of choice because of easier maintenance. The oxygen transfer capacities of surface, fine and coarse diffused air systems under standard conditions lie between 1.2-2.4,

1.2-2 and 0.6-1.2 kg O₂/kw.h., respectively.

13.4.3.1 DIFFUSED AIR AERATION

Diffused air aeration involves the introduction of compressed air into the sewage through submerged diffusers or nozzles. The aerators may be of the fine bubble or coarse bubble type. In the former, compressed air is released at or near the bottom of the aeration tank through porous tubes or plates made of aluminium oxide or silicon oxide grains cemented together in a ceramic matrix.

Air supplied to porous diffusers should contain less than 0.02 mg of dust per m³. Troubles due to clogging from the inside can be reduced by providing air filters and those due to clogging from outside can be avoided by providing adequate air pressure below the diffusers at all times. In spite of such precautions, fine bubble diffusers will require periodical cleaning.

Coarse bubble aerators have slightly lower aeration efficiency than fine bubble aerators but are cheaper in first cost and are less liable to clogging and do not require filtration of air. Air diffusers are generally placed along one side of the aeration tank, helping to set up a spiral flow in the tank which improves mixing and prevents the solids from settling. They are located 0.3m to 0.6m above tank floor to aid in tank cleaning and reduce clogging during shutdown. The agitator-sparjer is a special mechanical aerator system involving the release of compressed air at the bottom of the aeration tank in large bubbles and the breaking up of the bubbles into fine bubbles by submerged turbine rotors located above the air outlets. The turbine rotors also provide mixing.

13.4.3.2 SURFACE AERATORS

Surface aerators were linked to small installations in the past but with recent improvements in their design, they are being increasingly used for large plants in preference to diffused air aeration systems. Some of their advantages are higher oxygen transfer capacity, absence of air piping and air filter and simplicity of operation and maintenance.

Surface aerators generally consist of large diameter impeller plates revolving on vertical shaft at the surface of the liquid with or without draft tubes. A hydraulic jump is created by the impellers at the surface causing air entrainment in the sewage. The impellers also induce mixing. The speed of rotation of the impellers is usually 70-100 rpm for geared motor systems.

The aeration rotors for small oxidation ditches are generally of cage type but may also be of the angle iron type. Particular attention must be paid to the design of shaft length, bearings and alignment. Vertical shaft aerators are easier to maintain and are used with deeper ditches.

13.4.3.3 MIXING REQUIREMENTS

The aeration equipment have also to provide adequate mixing in the aeration tank to keep the solids in suspension. Mixing considerations require that the minimum power input in activated sludge aeration tanks where MLSS is of the arder of 4000-5000 mg/l, should not be less than $15-26 \text{ w/m}^3$ of tank volume. The power input of aerators derived from oxygenation considerations should be checked to satisfy the mixing requirements and increased where required.

13.4.4 Measuring Devices

Devices should be installed for indicating flow rates of raw sewage or primary effluent, return sludge and air to each aeration tank. For plants designed for sewage flow of 10 mld or more, integrating flow recorders should be used.

13.4.5 Secondary Settling

Secondary settling assumes considerable importance in the activated sludge process as the efficient separation of the biological sludge is necessary not only for ensuring final effluent quality but also for return of adequate sludge to maintain the MLSS level in the aeration tank. The secondary settling tank of the activated sludge process is particularly sensitive to fluctuations in flow rate and on this account it is recommended that the units be designed not only for average overflow rate but also for peak overflow rates. The high concentration of suspended solids in the effluent require that the solids loading rate should also be considered.

The recommended overflow rates and solids loading rates for secondary settling tanks of activated sludge have been given in Table 12.1.

13.4.6 Sludge Recycle

The MLSS concentration in the aeration tank is controlled by the sludge recirculation rate and the sludge settleability and thickening in the secondary sedimentation tank.

$$\frac{Q_R}{Q} = \frac{X}{X_s - X} \quad (13.10)$$

Where

$$Q_R = \text{Sludge recirculation rate, m}^3/\text{d}.$$

The sludge settleability is determined by sludge volume index (SVI) defined as volume occupied in ml by one gram of solids in the mixed liquor after settling for 30 min and is determined experimentally. If it is assumed that sedimentation of suspended solids in the laboratory is similar to that in sedimentation tank, then $X_s = 10^6/\text{SVI}$. Values of SVI between 100 and 150 ml/g indicate good settling of suspended solids and can be achieved for values suggested in Fig.13.3.

The X_s value may not be taken more than $10,000 \text{ g/m}^3$ unless separate thickeners are provided to concentrate the settled solids or secondary sedimentation tank is designed to yield a higher value. Using the above value for X_s and 5000 mg/l for X in Eq.(13.10), the sludge recirculation ratio comes out to be 1.0. The return sludge is always to be pumped and the recirculation ratio should be limited to the values suggested in Table 13.1.

13.4.7 Excess Sludge Wasting

The sludge generated in the aeration tank has to be wasted to maintain a steady level of MLSS in the system. The excess sludge quantity will increase with increasing F/M and decrease with increasing temperature.

The excess sludge generated under steady state operation may be estimated from Eq.(13.3) or (13.4).

In the case of domestic sewage, the excess sludge to be wasted will be about $0.35\text{-}0.5 \text{ kg/kg BOD}_5$ removed for the conventional system and about $0.25\text{-}0.35 \text{ Kg/Kg BOD}_5$ removed in the case of extended aeration plants having no primary settling. The volume of sludge to be wasted will depend on the suspended solids concentration in the waste stream.

Excess sludge may be wasted either from the sludge return line or directly from the aeration tank as mixed liquor. The latter procedure is to be preferred as the concentration of suspended solids will then be fairly steady in the waste stream providing better control on biomass wasted. The waste sludge is either discharged into the primary settling tank or thickened in a sludge thickening unit and digested directly. In extended aeration plants the excess sludge is taken to sludge drying beds directly and the sludge filtrate discharged into the effluent stream.

13.4.8 Nitrification

Activated sludge plants are ordinarily designed for the removal of only carbonaceous BOD. However, there may be incidental nitrification in the process. Nitrification will consume part of the oxygen supplied to the system and reduce the DO level in the aeration tank. Nitrification will also lead to subsequent denitrification in the secondary settling tank causing a rising sludge problem also called 'blanket rising'. Nitrification is aided by low F/M and long aeration time. It may be pronounced in extended aeration plants especially in hot weather. At the other extreme in the contact stabilisation process and in the modified aeration plant, there may be little or no nitrification.

Nitrification though generally not desired may be required in specific cases, e.g. when ammonia has to be eliminated from the effluent in the interest of pisciculture or when nitrification cum denitrification is proposed for elimination of nitrogenous matter from the effluent for control of eutrophication. In such cases, plug flow systems have been developed for efficient removal of both carbon and nitrogen. Alternatively a two stage system may be designed with carbonaceous BOD removal in the first stage and

nitrification in the second stage.

13.4.9 Operation

The most important aspect in the operation of an activated sludge plant is the maintenance of proper F/M which is achieved by increasing or decreasing the MLSS levels in the aeration tank to suit the influent BOD₅ loads. The MLSS in the aeration tank can be regulated by controlling the rate of sludge return based on SVI determined experimentally. Excess sludge wasting is generally controlled based on experience.

The quick settleability of sludge is an important factor in the efficient performance of the activated sludge plant. The SVI serves also as an index of sludge settleability. SVI values of 80-150 are considered satisfactory.

Sludge with poor settling characteristics is termed bulking sludge. Sludge bulking results in poor effluent due to the presence of excessive suspended solids and also in rapid loss of MLSS from aeration tank. Sludge bulking is generally due to inadequate air supply resulting in low pH or septicity and growth of filamentous organisms.

Sludge bulking is controlled by eliminating the causes and by application of chlorine either to the sewage or to the return sludge to control filamentous growths. Chlorine requirements are 0.2 to 1.0 percent of dry solids weight in return sludge.

Occasionally, the secondary settling tank may function poorly even when the sludge volume index is satisfactory and sludge may rise up in the tank and escape with the effluent. Rising sludge may be due to denitrification in the settling tank releasing nitrogen bubbles which buoy up the sludge. The problem can be overcome by increasing the return sludge rate, increasing the speed of the sludge scraper mechanism and increasing the sludge wasting rate.

TABLE 13.1
CHARACTERISTICS AND DESIGN PARAMETERS OF ACTIVATED SLUDGE
SYSTEMS FOR MUNICIPAL WASTEWATERS

Process Type	Flow regime	MLSS mg/l	MLVSS / MLSS	F/M KgBOD ₅ / Kg MLSS Day	HRT h	θ_c d	Q_a O	Eff %	Kg O ₂ / KG BOD ₅ removed
Conventional	Plug Flow	1500 - 3000	0.8	0.3 - 0.4	4 - 6	5 - 8	0.25 - 0.5	85 - 92	0.8 - 1.0
Completely mixed	Completely mixed	3000 - 4000	0.6	0.3 - 0.5	4 - 5	5 - 8	0.25 - 0.8	85 - 92	0.8 - 1.0
Extended aeration	Completely mixed	3000 - 5000	0.6	0.1 - 0.18	12 - 24	10 - 25	0.5 - 1.0	95 - 98	1.0 - 1.2

13.5 AERATED LAGOONS

Aerated lagoons are generally provided in the form of simple earthen basins with inlet at one end and outlet at the other to enable the wastewater to flow through while aeration is usually provided by mechanical means to stabilise the organic matter. The major difference between activated sludge systems and aerated lagoons is that in the latter settling tanks and sludge recirculation are absent.

Aerated lagoons are of two principal types depending on how the microbial mass of solids in the system is handled: Facultative Aerated Lagoons are those in which some solids may leave with the effluent stream and some settle down in the lagoon since aeration power input is just enough for oxygenation and not for keeping all solids in suspension. As the lower part of such lagoons may be anoxic or anaerobic while the upper layers are aerobic, the term facultative is used.

Aerobic Lagoons, on the other hand, are fully aerobic from top to bottom as the aeration power input is sufficiently high to keep all the solids in suspension besides meeting the oxygenation needs of the system. No settlement occurs in such lagoons and under equilibrium conditions the new (microbial) solids produced in the system equal the solids leaving the system. Thus, the solids concentration in the effluent is relatively high and some further treatment is generally provided after such lagoons. If the effluent is settled and the sludge recycled, the aerobic lagoon, in fact, becomes an activated sludge or extended aeration type lagoon.

A few typical characteristics of the above types of lagoons are given in Table (13.2) for ready reference.

Facultative type aerated lagoons have been more commonly used the world over because of their simplicity in operation and minimum need of machinery. They are often referred to simply as 'aerated lagoons'. Their original use came as a means of upgrading overloaded oxidation ponds in some countries without adding to the land requirement. In fact, much less land is required compared to oxidation ponds.

TABLE 13.2

SOME CHARACTERISTICS OF AERATED LAGOONS

Sl.No.	Characteristics	Facultative Aerated Lagoons	Fully Aerobic	Extended Aeration System (for comparison)
1.	Detention time, days.	3 - 5	2 - 3	0.5 - 1.0
2.	Depth, m	2.5 - 5.0	2.5 - 4.0	2.5 - 4.0
3.	Land required, sq.m/person	0.15 - 0.30	0.10 - 0.20	-
4.	BOD removal efficiency %	80 - 90	50 - 60	95 - 98
5.	Overall BOD removal rate, K, per day 20° C (soluble only)	0.6 - 0.8	1 - 1.5	20 - 30
6.	Suspended solids (SS) in unit, mg/l	40 - 150	150 - 350	3000 - 5000
7.	VSS/SS	0.6	0.8	0.6
8.	Desirable power level watts/Cu.m. of lagoon volume	0.75	2.75 - 6.0	15 - 18
9.	Power requirement, kWh/person/year	12 - 15	12 - 14	16 - 20

In earlier times the design of aerated lagoons was often done using simple thumb-rules of detention time and power per capita. But, over the years it has come to be recognised that lagoons being large bodies of water are subject to seasonal temperature effects and flow mixing conditions. Flow conditions in aerated lagoons are neither ideal complete-mixing nor ideal plug-flow in nature. They are dependent on lagoon geometry and are better described by dispersed flow models of the type given by Wehner and Wilhelm for first-order kinetics and hence the design procedure given below takes treatability of the waste, temperature and mixing conditions into account.

Fully aerobic lagoons always have a complete-mixing regime and a slightly different mode of design is followed. However, as aerobic lagoons have not yet been built in India (except one case) further discussion is limited to facultative aerated lagoons only.

13.6 DESIGN VARIABLES

For facultative aerated lagoons, the dispersed flow model just referred to gives the relation between influent and effluent substrate concentrations. So and S, respectively and other variables such as the nature of the waste, the detention time and the mixing conditions, as shown in Equation.

$$\frac{S}{S_0} = \frac{4 a \cdot e^{1/2 d}}{(1 + a)^2 e^{a/2 d} - (1 - a)^2 e^{-a/2 d}} \quad (13.11)$$

in which the term $a = \sqrt{1 + 4K\theta \cdot d}$

d = dispersion number (dimensionless)

$$= D/UL = D.\Theta/L^2$$

in which, D = Axial dispersion coefficient (length²/time)

L = Length of axial travel path

Θ = theoretical detention time, (Volume/Flow rate)

U = velocity of flow through lagoon (length/time)

K = Substrate removal rate in lagoon (time⁻¹)

S₀ & S = Initial and final substrate concentrations (mass/volume)

A graphical solution of the above equation is shown in Fig. 13.4 from which it is seen that prior knowledge of the substrate removal rate K as well as of the mixing condition likely to prevail in a lagoon is necessary to determine the efficiency of BOD removal at selected detention time. This is discussed further below.

13.6.1 Mixing Conditions

The mixing conditions in a lagoon are reflected by the term 'd' which is known as the "Dispersion Number" and equals (D / UL) or (D Θ / L²). It is affected by various factors. Observed results have shown the (D / UL) values to be in the approximate range given in Table (13.3) for different length-width ratios of lagoons.

By suitable choice of a lagoon's geometry one can promote either more plug flow or more complete mixing type of conditions. Fig. 13.5 gives some examples of different types of arrangements using baffles or cells in series. In case of cells in series, each cell may be well mixed with value of D/UL approaching 3.0 or 4.0 but overall the arrangements would give a relatively plug-flow type arrangement. Values of D/UL can be determined by conducting dye (tracer) tests on existing units using well-known methods, but where D/UL values are required for design purposes prior to construction, they can be estimated either from lab-scale models or by using empirical equations available. Low values of D/UL signify plug flow conditions and generally give higher efficiencies of substrate removal whereas the converse is the case with higher values of D/UL. However, process efficiency is not the only consideration; process stability under fluctuating inflow quality and quantity conditions, has also to be kept in view. For municipal or domestic sewage, relatively plug flow type conditions (i.e. low values of D/UL) are preferred. In case of industrial wastes, relatively well mixed condition may be preferred (i.e. higher values D/UL) depending upon the nature of the industrial waste; the greater the fluctuations in quality and quantity of industrial wastes, the greater the advantage in adopting well-mixed conditions.

TABLE 13.3

LIKELY VALUES OF DISPERSION NUMBERS D/UL AT DIFFERENT LENGTH-WIDTH RATIOS

Aerated Lagoon	Approximate range of D/UL values.	Typical mixing condition
Length-width ratio 1 : 1 to 4 : 1	3.0 to 4.0 and over	Well mixed
Length-width ratio 8 : 1 or more	0.2 - 0.6	Approaching plug flow
Two or Three cells in series	0.2 - 0.6 (overall)	-- do --

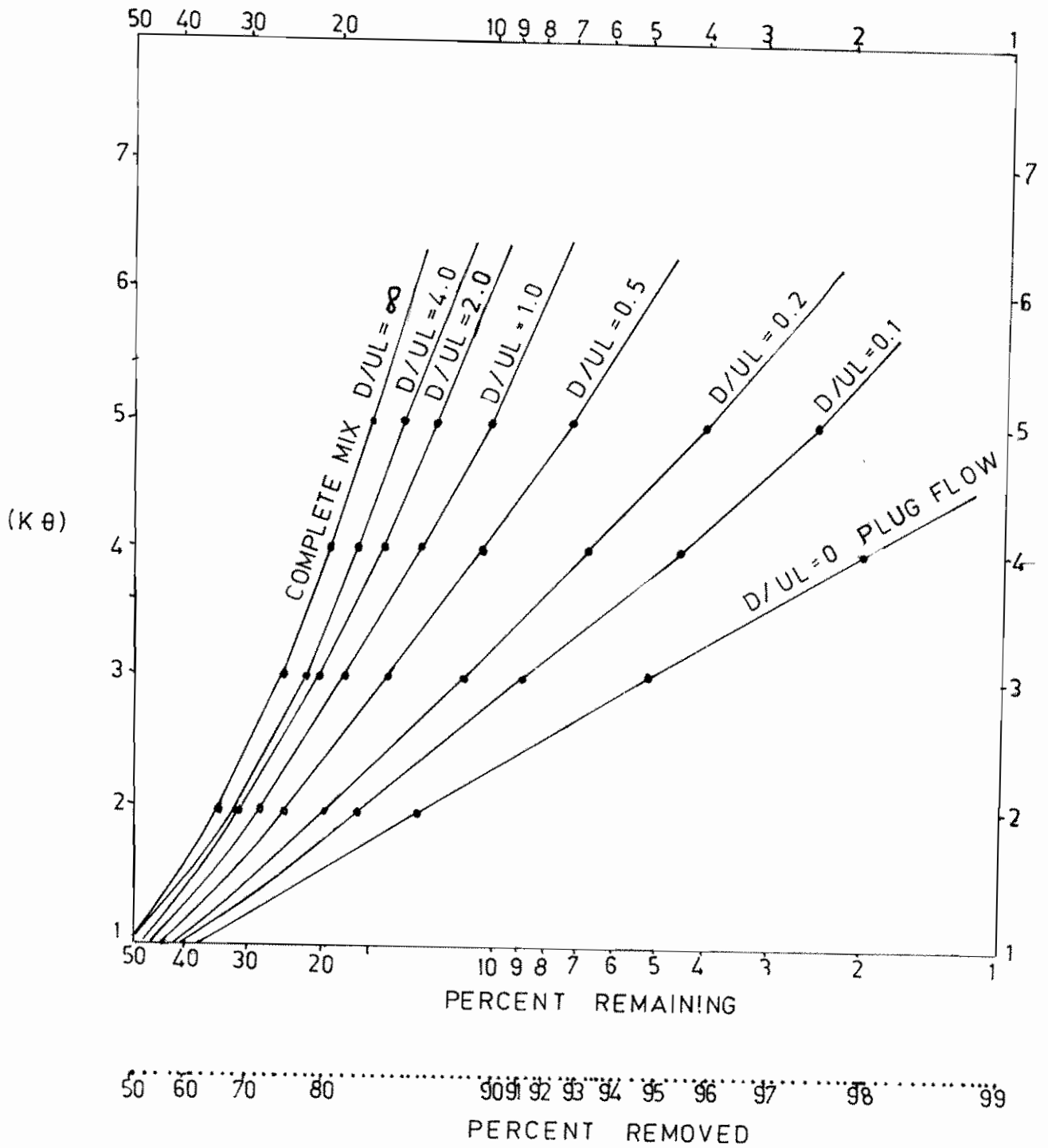

FIG.13.4 : SUBSTRATE REMOVAL EFFICIENCY USING THE DISPERSED FLOW MODEL (WEHNER-WILHEM EQUATION)

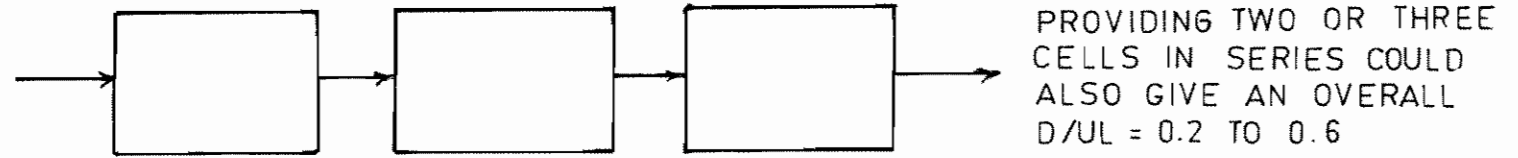
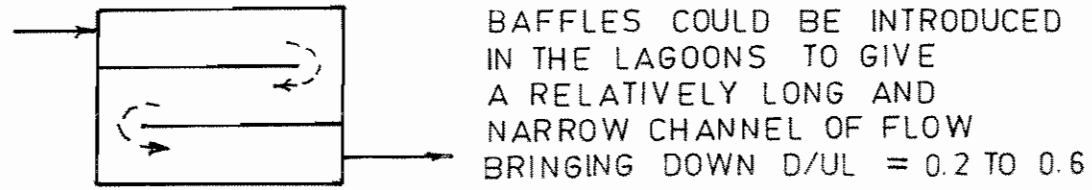
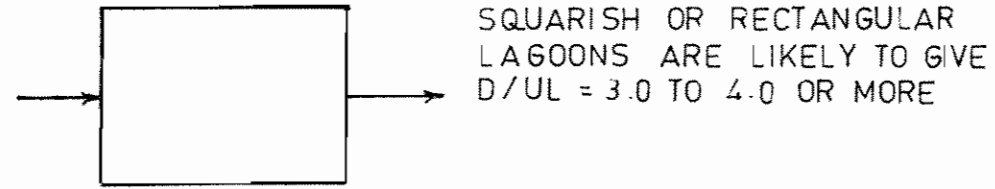

FIG.13.5 : ESTIMATED EFFECT OF LAGOON GEOMETRY ON VALUE OF DISPERSION NUMBER D/UL

Lagoons are generally rectangular in shape though it is not absolutely essential. Natural land contours may be followed to the extent possible to save on earthwork. Lagoon units may be built with different length-width ratios and arrangement of internal baffles to promote desired mixing conditions.

Lagoons may also be provided as two or three stage systems with the subsequent units placed at a lower level than the first if desired.

Construction techniques for aerated lagoons are similar to those used in case of oxidation ponds with earthen embankments. Pitching of the embankment is desirable to protect it against erosion. In cases where soil percolation is expected, suitable lining may have to be provided to maintain the design level in the lagoon and avoid ground water pollution.

13.6.2 Substrate Removal Rates

As shown in Table 13.2 for facultative aerated lagoons the overall substrate removal rate K for sewage varies from 0.6 - 0.8 per day (soluble BOD basis) at 20 deg. C. At other temperatures in lagoons the values are obtained from:

$$(K)_{T^{\circ}C} = (K)_{20^{\circ}C} \times (1.035)^{T-20} \quad (13.12)$$

The temperature in a lagoon T_L is estimated from the following equation:

$$\frac{\Theta}{h} = \frac{T_i - T_L}{f(T_L - T_a)} \quad (13.13)$$

in which Θ = detention time, days, h = depth of lagoon, meters, while T_i and T_a are the temperatures ($^{\circ}C$) of influent wastewater and ambient air respectively and the heat transfer coefficient $f = 0.49$ m/day for aerated lagoons. The average winter month temperature is critical for determining the detention time required. As stated earlier, the detention time to be provided in a lagoon can be determined from Eq.13.11 or Fig 13.4 for any desired efficiency for the computed temperature and mixing conditions in the lagoon.

13.6.3 Power Level

The power input in facultative aerated lagoons has to be adequate only to diffuse dissolved oxygen uniformly in the system; no effort is made to keep the solids in suspension. Hence, a minimum power level of 0.75 Watts per cu.m lagoon volume should be adequate, but this should be checked with the aeration equipment supplier for its oxygenation characteristics and compatibility with proposed depth and shape of lagoon:

For treating domestic sewage the power requirement varies from 12 - 15 kWh/person/year or 2 - 2.5 HP per 1000 population equivalent. The oxygenation capacity of aerators is reported to range from 1.87 to 2.0 kg. Oxygen/kWh at standard conditions for power delivered at shaft. Spacing of aerators should be adequate for uniform aeration all over the lagoon area without much overlap of the circle of influence of adjoining aerators as specified by the manufacturers. A minimum of two aerators would be desirable to provide to make up the total power requirement.

Aerators ranging from 3 HP to 75 HP are now readily available in the country. They can be either floating or fixed type. Floating aerators are mounted on pontoons (which should be corrosion-free). They have the advantage of being able to adjust themselves to actual levels obtaining in the lagoons due to seepage and/or fluctuating inflows. Fixed aerators are mounted on structural columns and carefully levelled with regard to the outlet weir level to ensure required submergence of aerator

blades to give the design oxygenation capacity.

13.6.4 Effluent Characteristics

The effluent is generally made to flow over an outlet weir. As the concentration of solids passing out in the effluent may be nearly the same as that in the lagoon the BOD corresponding to the volatile fraction of these solids (assumed as 0.77 mg per mg VSS in effluent) should be added to the value of the soluble BOD, S , obtained by use of Eq.13.11 or Fig.13.4. Thus, the final effluent BOD is given by:

$$\text{Final BOD, mg/l} = S, \text{ mg/l} + (0.77) (\text{VSS in effluent}), \text{ mg/l}$$

It is because of the suspended solids (expected to range from 40 to 60 mg/l in case of domestic sewage) in the final effluent that the total effluent BOD is difficult to reduce below 30 - 40 mg/l in winter. At other times of the year BOD less than 30 mg/l may be possible. This range of BOD is more than adequate for irrigational purposes, but for river disposal the applicable standards should be ascertained and design made accordingly. Where necessary, further reduction of BOD can be achieved either by a small increase in detention time or by more efficient interception of solids flowing out (e.g. deeper baffle plate ahead of outlet weir) or by provision of an additional treatment unit.

Nitrification is not likely to occur in aerated lagoons. Coliform removal shows considerable seasonal variation (60 - 90% removal).

13.6.5 Sludge Accumulation

Sludge accumulation occurs at the rate of 0.03 - 0.05 cu.m per person per year as in the case of oxidation ponds and is manually removed once in 5 - 10 years and used as good agricultural soil. The depth of the lagoon may be increased a little to allow for sludge accumulation, if desired.

13.7 CONCLUSION

The removal efficiencies in terms of power input are comparable to some of the other aerobic treatment methods seen earlier in this chapter but the greatest advantage with aerated lagoons lies in their simplicity and ruggedness in operation, the only moving piece of equipment being the aerator. Civil construction mainly entails earthwork, and land requirement is not excessive.

AEROBIC ATTACHED GROWTH SYSTEMS

AEROBIC ATTACHED GROWTH SYSTEMS

14.1 GENERAL CONSIDERATIONS

Biological unit processes are broadly classified as suspended growth systems or attached growth systems depending on whether the microbial population remains suspended in the liquid medium or attached to inert support medium. Bioreactors in which biomass grows attached to inert medium such as rocks, slag or specially designed ceramic, plastic material or synthetic materials under aerobic conditions constitute aerobic attached growth systems. Trickling Filters and Rotating Biological Contactors are examples of such systems. These systems, also referred to as fixed film reactors, have been widely employed for removal of organic pollutants and for nitrification.

14.2 TRICKLING FILTERS

Trickling filters are used for the biological treatment of domestic sewage and industrial wastes which are amenable to aerobic biological processes. They find use for complete treatment of moderately strong wastes and as roughing filter for very strong wastes prior to activated sludge units. Trickling filters possess a unique capacity to handle shock loads and provide dependable performance with a minimum of supervision.

The trickling filter consists of a permeable bed of medium through which the sewage or liquid waste is allowed to percolate. The materials used as filter medium include crushed or broken rock, gravel, blast furnace slag or inert synthetic materials such as plastics and ceramics. Randomly packed solid media like rock, gravel and slag are characterised by lower porosities (40-60%), lower specific surface areas ($40-70 \text{ m}^2/\text{m}^3$) and lower depths of 0.9 to 2.5 m. Plastic media of various shapes possess very high porosities (94-97%), and higher specific surface areas ($80-200 \text{ m}^2/\text{m}^3$). While conventional filters usually employ rocks, gravel and slag as filter medium, plastic media are generally used in super rate filters which operate at much higher hydraulic and organic loading rates and are much deeper (upto 12 m) compared to conventional filters. The deep filters containing plastic media are referred to as biotowers and have been used for both domestic and strong industrial wastewaters. The trickling filters may be generally circular but square or rectangular shapes may also be used. The sewage is evenly distributed on the surface of filter medium and the treated effluent is collected by the underdrains.

The trickling filter is preceded by primary sedimentation so that the settleable solids in the sewage may not clog the filter. The sedimentation tanks should have skimmers to remove the scum. The trickling filter is always followed by a final settling tank to remove from the filter effluent the settleable organic solids produced in the filtration process. In some cases, it may be advantageous to provide skimming devices for the final settling tanks also. The trickling filter serves both to oxidise and bioflocculate the organic material in sewage and their efficiency is assessed on the total reduction in BOD effected through the filter and the subsequent settling tank, since the effluent quality is reckoned after the settlement of the bioflocculated solids.

14.2.1 Process Description

As the wastewater trickles through the filter media, biomass grows attached to the media surfaces, normally in a period of two weeks, making the filter ready for operation. During operation, the organic material present in wastewater is metabolised by the biomass attached to the contact medium. The attached biomass is referred to as the biological film or slime layer. The biological slime grows in thickness as the organic matter abstracted from the flowing wastewater is synthesized into new cellular material. The grown slime layer which usually has a total thickness between 0.1 and

2.0mm consists of both aerobic and anaerobic layers. The thickness of the aerobic layer is limited by the depth of penetration of oxygen into microbial layer which depends upon the coefficient of diffusivity of oxygen in the film, the concentration of oxygen at the solid-liquid interface and the overall oxygen utilization rate of microorganisms present in the slime layer.

Utilisation of substrate by the micro-organisms results in increased thickness of the slime layer and the organic matter removed from wastewater is metabolised before it can reach the microorganisms near the media face. As a result of having no external organic source available for cell carbon, the microorganisms near the media face enter into endogenous phase of growth and lose their ability to cling to the media surface. The liquid then washes the slime off the medium and a new slime layer starts to grow. This phenomenon of losing the slime layer is called 'sloughing'.

The sloughed off film and the treated wastewater are collected by an underdrainage system which also allows circulation of air through filter. The collected liquid is passed to a settling tank used for solid-liquid separation.

Filter sloughing aids ventilation by keeping the filter medium open. It also continuously renews the biota, maintaining it active which is essential for the efficient functioning of the filter. The degree of filter sloughing will depend on the organic loading which will control the growth of the slime and the hydraulic loading which will influence its scour.

14.2.2 Types of Filters

Trickling filters may be categorised as low rate, high rate and super rate, primarily based on hydraulic and organic loading rates. Although there is no well demarcated practice, some important distinguishing design criteria and features for the three types of filters are presented in Table 14.1.

TABLE 14.1
DESIGN FEATURES FOR TRICKLING FILTERS

Sl.No.	Design Feature	Low Rate Filter	High Rate Filter	Super Rate or Roughing Filter
1.	Hydraulic loading, m ³ /m ² . d	1 - 4	10 - 40 (including recirculation)	40 - 200 (including recirculation)
2.	Organic loading kg BOD ₅ / m ³ . d	0.08 - 0.32	0.32 - 1.0 (excluding recirculation)	0.8 - 6.0 (excluding recirculation)
3.	Depth, m	1.8 - 3.0	0.9 - 2.5	4.5 - 12
4.	Recirculation ratio	0	0.5 - 3.0 (domestic wastewater) upto 8 or more for strong industrial wastes	1 - 4
5.	Filter media	Rock, gravel, slag etc.	Rock, slag, synthetic materials	Plastic media

The hydraulic loading rate is the total flow including recirculation applied on unit area of the filter in a day, while the organic loading rate is the 5-day 20°C BOD, excluding the BOD of the recirculant, applied per unit volume in a day. Much higher organic loadings than indicated above have been used in roughing filters.

Recirculation is not generally adopted in low rate filters. Media depths for low rate filters range from 1.8m to 3.0m. They require larger media volumes than high rate filters. However, they are easy to operate and give consistently good quality of effluent and are preferred when plant capacities are small as in the case for institutions.

In contrast to the low rate filters, in high and super rate filters a part of the settled or filter effluent is recycled through the filter. Recirculation has the advantage of bringing the organic matter in the waste in contact with the biological slime more than once, thus increasing the efficiency of the filters. It enables higher hydraulic loading and thereby reduces filter clogging and aids uniform distribution of organic load over the filter surface. It also helps to dampen the variations in the strength and the flow of sewage applied on the filter. The ratio of the recycled flow to the sewage flow is known as the recirculation ratio. Recirculation ratios usually range from 0.5 to 3 and values exceeding 3 are considered to be uneconomical in the case of domestic sewage but ratios of 8 and above have been used with industrial wastes and super high rate filters, may be single stage or two stage. Media depths of 0.9 to 2.5 m have been used for high rate filters with an optimum range of 1.5m to 2.0m for the first stage and 1 to 2m for the second stage filters. Single stage units consist of a primary settling tank, the filter, secondary settling tank and facilities for recirculation of the effluent. Various patterns of recirculation are given in (a), (b) and (c) of Fig.14.1 A.

Two stage filters consist of two filters in series with a primary settling tank, an intermediate settling tank which may be omitted in certain cases and a final settling tank. Recirculation facilities are provided for each stage. The effluent from the first stage filter is applied on the second stage filter either after settlement or without settlement. Some of the common flow diagrams are shown in Fig. 14.1 B. In 14.1 B(a), an intermediate clarifier is used for settling the first stage effluent before it is applied to the second stage filter and the recirculation is only through the settling tanks. In 14.1 B(b) the intermediate settling is omitted and the recirculation flows are settled. In 14.1 B(c), which is known as the series-parallel system, part of the settled raw sewage is applied directly to the second stage filter increasing the efficiency of that stage. In 14.1 B(d), there is neither intermediate settling nor settling of filter effluent prior to recirculation.

Two stage filtration will provide a higher degree of treatment than the single stage for the same total volume of media. Two-stage units are used for strong sewage when the effluent BOD has to be less than 30 mg/l.

A well operated low rate trickling filter in combination with secondary sedimentation tank may remove 75 to 90 percent BOD and produce highly nitrified effluent. It is suitable for treatment of low to medium strength domestic wastewaters. The high rate trickling filter, single stage and two stage, are recommended for medium to relatively high strength domestic and industrial wastewaters. The BOD removal efficiency is around 75 to 90 percent but the effluent is only partially nitrified. The super rate or roughing filters find application for high-strength wastewaters. They have also been used as roughing filters to reduce the BOD of high strength wastewaters for further treatment. The effluent from these filters may be partially nitrified only when low organic loadings are employed.

14.2.3 Process Design

The rational design of any biological treatment unit is normally contemplated employing the Monod's equation and associated biokinetic coefficients as used in the design of completely-mixed activated sludge process. The evaluation of kinetic coefficients involves determination of microorganism concentration and the hydraulic flow pattern which have not yet been adequately and precisely evaluated. Therefore completely theoretical kinetic or mechanistic model has not been developed that will accurately predict filter performance due to the unstable characteristics of the slime layer and complex inter-relationships between process variables.

Various empirical design equations based on experience and analysis of data have been developed. These include Rankin's Equation, National Research Council (NRC) of Canada and Gotaas equation. Equations developed by Velz, Eckenfelder and Atkinson have been derived from principles governing the performance of trickling filter. The latter type of equations involves some constants which should be preferably evaluated by conducting laboratory/pilot plant studies. In case it is not possible to conduct experimental studies, empirical design equations may be used.

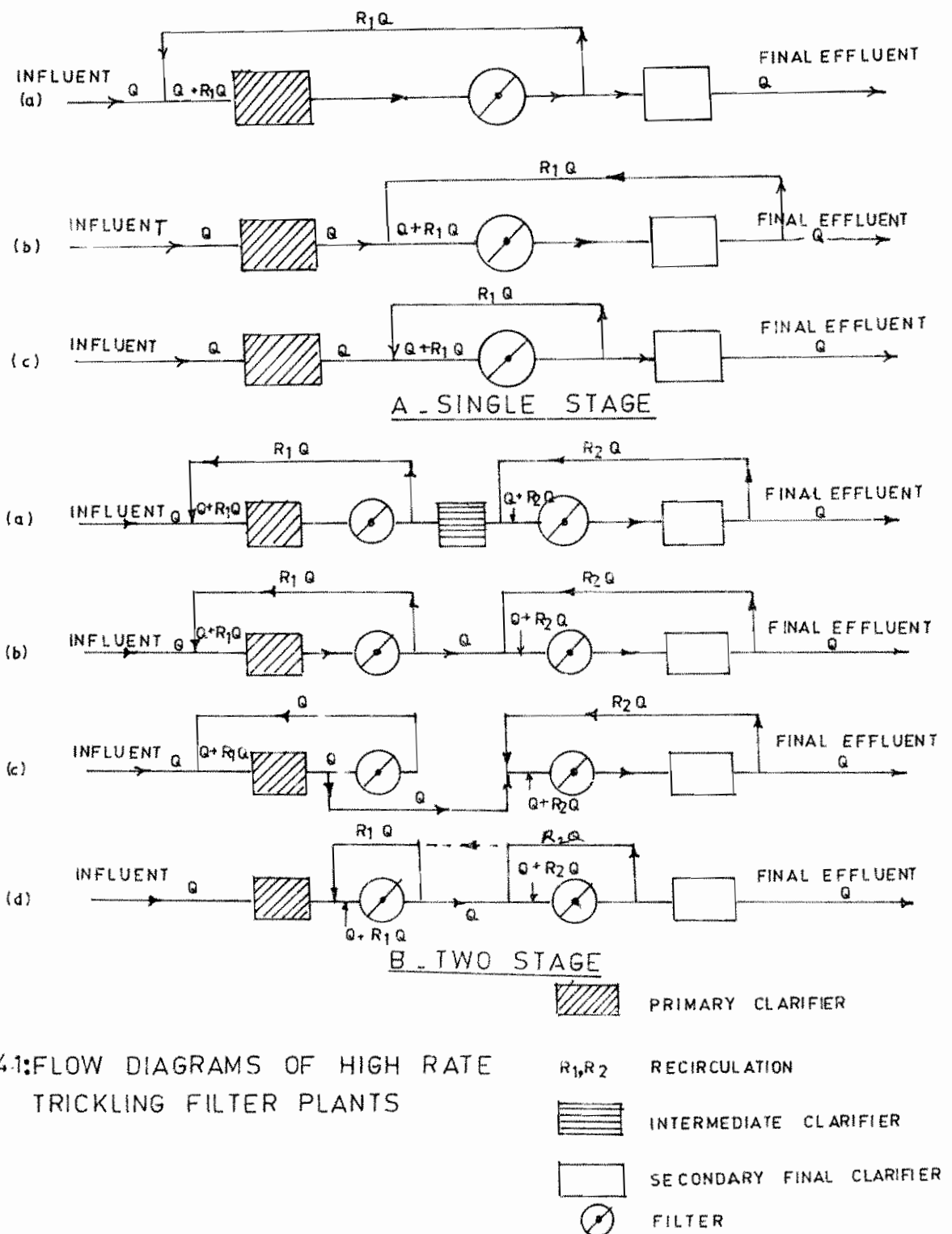

FIG.14-1: FLOW DIAGRAMS OF HIGH RATE TRICKLING FILTER PLANTS

14.2.3.1 RANKIN'S EQUATION

Rankin developed a set of equations for the performance of high rate filters of various flow diagrams based on the requirements of the Ten State Standards of U.S.A. The basic principle is that the BOD of the influent to the filter including recirculation shall not exceed three times the BOD of the required settled effluent.

14.2.3.2 NATIONAL RESEARCH COUNCIL (CANADA) EQUATION

The NRC equation for trickling filter performance are empirical expressions developed from a study of the operation results of trickling filters serving military installations in U.S.A. These equations are applicable to both low rate and high rate filters.

The efficiency of single stage or first stage of two stage filters E_2 is given by:

$$E_2 = \frac{100}{1 + 0.44 \sqrt{\frac{W_1}{V_1 F_1}}} \quad (14.1)$$

For the second stage, the efficiency

$$E_3 = \frac{100}{1 + \frac{0.44}{(1-E_2)} \sqrt{\frac{W_1(1-E_2)}{V_2 F_2}}} \quad (14.2)$$

$$= \frac{100}{1 + \frac{0.44}{(1-E_2)} \sqrt{\frac{W_2}{V_2 F_2}}}$$

Where

- E_2 = percentage efficiency of BOD removal of the single stage or first stage of the two stage filter
- E_3 = percentage efficiency of second stage filter
- W_1 = BOD loading of settled raw sewage in the single stage or first stage of the two stage filter in kg/day
- W_2 = $W_1 (1-E_2)$ = BOD loading on second stage filter in kg/day
- V_1 = Volume of first stage filter in m^3
- V_2 = Volume of second stage filter in m^3

- F_1 = Recirculation factor or number of effective passes for first stage filter

$$= \frac{1 + R_1}{[1 + (1 - f) R_1]^2}$$
 R_1 = recirculation ratio for the first stage filter
 f = treatability factor (0.9 for sewage).
 F_2 = recirculation factor or number of effective passes for second stage filter

$$= \frac{1 + R_2}{[1 + (1 - f) R_2]^2}$$
 and
 R_2 = recirculation ratio for the second stage filter.

14.2.3.3 ECKENFELDER EQUATION

Eckenfelder assumed that trickling filter can be represented as a plugflow reactor and that substrate utilisation follows the first order kinetics. He considered the effect of time of contact between wastewater and microorganisms through the measurable variables of depth of filter media and surface hydraulic loading as well as of microorganism concentration which is related to the specific surface area of the filter media and other factors. Eckenfelder's equation can be written as:

$$\frac{L_e}{L_o} = \exp\left[\frac{-K_o D}{(QA)^n}\right] \quad (14.3)$$

Where

- L_e - soluble BOD of filter effluent, mg/l
 L_o - influent BOD (including recirculation), mg/l
 K_o - treatability factor min^{-1}
 D - filter media depth, m
 QA - hydraulic surface loading $\text{m}^3/\text{m}^2 \cdot \text{min}$
 n - constant

For design of trickling filter, treatability studies to evaluate the constant involved in the rational design equation such as those of Eckenfelder and Atkinson based on pilot plant model's performance are most desirable and should receive due attention especially with industrial wastewater treatment. A brief procedure to conduct treatability studies and to evaluate constant in Eckenfelder's approach is described in following paragraph.

A bench-scale cylindrical column (typical dimensions being 200 mm diameter, 2 m or more in height), preferably of plexiglass, having adequate number (minimum three) of sampling ports, is filled with filter medium. Suitable arrangements for feeding the wastewater at 3 to 4 hydraulic surface

loadings are made.

The filter is fed with wastewater to be treated to generate slime layer on the filter medium which may take from a few days to several weeks depending on the nature of the wastewater. The filter is operated at several hydraulic surface loadings by changing the flow rate and steady state effluent substrate concentration (BOD or COD) remaining at different depths is determined. Percent BOD (or COD) remaining versus sampling depths is plotted on semilog paper for each of the hydraulic loadings and the slope of each straight line is determined. A log-log plot of slope versus surface loading is drawn. The slope of the line gives the value of constant, n .

$$\frac{L_e}{L_o} = \text{Exp} \left[\frac{K_o D}{\left(\frac{Q}{A}\right)^n} \right]$$

or

$$2.303 \log \left(\frac{L_e}{L_o} \right) = \frac{K_o D}{\left(\frac{Q}{A}\right)^n}$$

$$\text{Slope} = \frac{K_o \left(\frac{Q}{A}\right)^n}{2.303}$$

or

$$\log(2.303 \times \text{slope}) = \log K_o + n \log \left(\frac{Q}{A}\right)$$

A table of $\left[\frac{D}{(Q/A)^n}\right]$ versus $\left(\frac{L_e}{L_o}\right) \times 100$ for various values of D and (Q/A) is constructed and on a semilog graph paper $\left(\frac{L_e}{L_o}\right) \times 100$ versus $\left[\frac{D}{(Q/A)^n}\right]$ is plotted. The slope of the straight line gives the value of treatability factor, K_o .

The values of treatability factor, K_o , range from 0.01 to 0.1. Average values for municipal wastewater for filters using plastic media have been reported to be around 0.06 at 20° C. The coefficient n for plastic media modular construction, can be assumed as 0.5 without significant error.

14.2.3.4 APPLICABILITY OF THE DIFFERENT EQUATIONS

The Eckenfelder equation is based on rational approach as it considers the effect of specific surface area of filter medium and time of contact between wastewater and microorganisms. This approach is versatile and applicable to low rate, high rate and super rate filters using plastic media. The application of this equation requires that bench or pilot scale treatability studies should be conducted or the values of treatability factor, K_o and constant n should be known. If it is not possible

to conduct treatability studies or values of K_d and n cannot be assumed, empirical equations may be used. However, considerably different filter volumes are obtained by using different empirical equations for any given situation. In general, Rankin's approach has been found to give fairly satisfactory results in Indian conditions. The NRC equations would seem to apply when recirculation is not considered, when seasonal variations in temperatures are not large and when sewage load is highly variable and of high strength.

14.2.4 Constructional Features

14.2.4.1 SHAPE OF FILTER

Filters may have circular, rectangular or square shape. If fixed nozzles or nozzles mounted on moveable arms are used for flow distribution, rectangular or square shapes are employed. For rotary distribution, circular shape is used. The circular shape also has the advantage of structural economy.

14.2.4.2 PROVISION FOR FILTER FLOODING

Provision for flooding the filters is useful for controlling filter flies and ponding. To enable flooding, the filter walls must be designed for the internal water pressure and the main collecting channel must be placed inside the filter and provided with gate valves. An overflow pipe leading from the filter to the main collecting channel down-stream from the gate valve is also necessary.

Provision for filter flooding should always be made in the case of small filters, especially the low rate filters. Such a provision in large filters would not only increase the cost but is also likely to cause hydraulic problems with the sudden discharge of large volumes of sewage when the flooded filter is drained. In such cases alternate methods may be required for controlling filter flies and ponding.

14.2.4.3 FILTER WALLS

Filter walls may be of reinforced concrete, brick or stone masonry or hollow concrete blocks. For flooding operation, reinforced concrete is preferred.

14.2.4.4 FILTER FLOOR

The filter floor is designed to support the under-drainage system and the superimposed filter media. The usual practice is to provide a nominally reinforced cement concrete slab 10-15 cm thick, over a proper levelling course. The floor should slope between 0.5 and 5% towards the main collecting channel. The flatter slopes are used in larger filters.

14.2.4.5 UNDER-DRAINAGE SYSTEM

The underdrainage system is intended to collect the trickling sewage and sloughed solids and to convey them to the main collecting channel and also to ventilate the filter media. The underdrains cover the entire floor of the filter to form a false bottom and consist of drains with semi-circular or equivalent inverts. They will be formed of precast vitrified clay or concrete blocks, complete with perforated cover or they may be formed insitu with concrete or brick and covered with perforated precast concrete slabs.

The slope of the underdrains should be the same as that of the floor. The drains shall be so sized that flow occupies less than 50% of the cross-sectional area with velocities not less than 0.6 mps at average design flow. The cover over the drains shall be perforated to provide a total area of inlet openings into the drains not less than 15% of the surface area of the filter. Underdrains may be open at both ends so that they may be inspected easily and flushed out if they become clogged.

14.2.4.6 MAIN COLLECTING CHANNEL

The main collecting channel is provided to carry away the flow from the underdrains and to admit air to the filter. In a circular filter, the main channel may be located along the diameter with a slight offset from the centre. Alternatively the channel may be provided along the outer periphery of the filter. If inside the filter, the channel shall be provided with perforated covers to enable drainage and also ventilation of the filter media above the channel. The channel should be extended outside the filter, both at the upper end and lower ends with vented manholes to facilitate ventilation and access for cleaning.

The channels shall have semicircular or other rounded inverts. The velocity in the channels shall not be less than 0.6 mps for the average hydraulic loading. The flow shall be only half-depth particularly where recirculation is low. At the peak instantaneous hydraulic loading, the water level in the channel should not rise above the inverts of the underdrains at their junctions with the channel.

14.2.4.7 VENTILATION

Adequate natural ventilation can be ensured by proper design of the underdrains and effluent channels. For filters larger than 30 m dia., a peripheral head channel on the inside of the filter with vertical vents is desirable to improve ventilation. 1 m² of open grating in ventilating manholes and vent stacks should be provided for 250 m² of filter area. The vertical vents can also be used for flushing the underdrains.

In extremely deep or heavily loaded filters there may be some advantage in forced ventilation if it is properly designed, installed and operated. Such a design should provide for an air flow of 1 m³/min/m² of filter area in either direction.

It may be necessary during periods of extremely low air temperature to restrict the flow of air through the filter to keep it from freezing. However a minimum air flow of 0.1 m³/min/m² of filter area should be provided.

14.2.4.8 FILTER MEDIA

The requirements for filter media are high specific surface area, high percent void space, resistance to abrasion or disintegration during placement, insolubility in sewage or other waste water and resistance to spalling and flaking.

The most commonly used filter media is broken stone (trap rock, granite or limestone), slag or gravel of size 25 to 75mm. The filter material should be washed before it is placed in position. The Brinell Hardness number of the medium should be 12. Such media should be round or cubical in shape and free of thin, elongated and flat pieces. Not more than 5% of the media (by weight) should have the longest dimension greater than 3 times the smallest dimension.

Stones less than 25 mm dia, do not provide sufficient pore space between them to permit free flow of sewage and sloughed solids and also lead to plugging of media and ponding of filters. Large size stones greater than 100mm dia, overcome the plugging problem but due to relatively smaller surface area per unit volume cannot support as large a microbial population as the smaller size stones.

The size of the filter media is of considerable significance as the specific surface area decreases with increase in media size but the percent void space increases as given in Table 14.2.

TABLE 14.2

RECENT VOID SPACE FOR VARIOUS FILTER MEDIA

Media	Size (in mm)	Specific Surface area m^2/m^3	% Void Space
Granite	25 - 75	62	46
Granite	100	43	60
Blast furnace slag	30 - 75	65	49
Plastic		80 - 200	97

The recent trend is towards the use of larger media especially for high rate filters. The current specification for stone media is that when mechanically graded over vibratory screens:

100% should pass through 110 mm square mesh

95-100% should be retained on 75mm sq.mesh

0.2% alone should pass through 50mm sq.mesh

0.1% alone should pass through 25mm sq.mesh

(% given are by weight)

Media shall be placed and packed by hand for at least a height of 30 cm above the underdrains to avoid damage to the underdrainage system. The remainder of the material may be placed by means of wheel barrows or boxes or by belt conveyors. They should not be dumped or tipped from lorries.

14.2.4.9 PLASTIC MEDIA

The above criteria do not apply to plastic synthetic media which have high specific surface area, high void space and low weight. Synthetic filter media have of late been used successfully in super rate filters for the treatment of strong industrial wastes or sewage mixed with strong industrial wastes having hydraulic loading rates in the range of 40-200 $m^3/d/m^2$ and organic loading rates of 0.8-6.0 kg BOD/d/ m^3 . The media consists of interlocking sheets of plastics which are arranged in a honeycomb fashion to produce a porous and nonclog filter media. The sheets are corrugated so that a strong, lightweight media is obtained. Filters as deep as 12 m have been used with this type of synthetic media.

14.2.4.10 FILTER DOSING

In the case of low rate filters, the minimum flow rate of sewage inflow may not be sufficient to rotate the distributor and discharge sewage from all nozzles. Hence, when adequate head is available dosing tank is provided to collect the settled sewage and dose the filter through a siphon intermittently. When head is inadequate, a collection well is provided to store the sewage and a suction level controlled pump, intermittently pumps the sewage to the filter. The dosing siphons are designed to dose the filters once in about 5 minutes under average flow conditions. In the case of high rate filters, there is no need for the special dosing device since continuous dosing is possible.

14.2.4.11 FLOW DISTRIBUTION

Fixed nozzle distributors are not preferred because of the elaborate piping requirement and the necessity of dosing tanks, siphons or motor operated valves to obtain variable dosing rates. Among the moving types, the longitudinally travelling distributors are not common because of the long resting period associated with their time of travel from one end of the bed to the other and the need for a reversing gear at each end of the bed to change the direction of motion.

The present practice is to use only reaction type rotary distributors. Rotary distributors are commercially available in the country upto 60 m dia. The piping to the distributor is generally taken below the filter floor and in rare case through the filter media just above the underdrains. The pipe should be designed for a peak velocity of not greater than 2.0 mps and an average velocity not less than 1 mps.

The reaction type rotary distributor consists of a feed column at the centre of the filter, a turntable assembly at the top and two or more hollow radial distributor arms with orifices. The turntable should be provided with antitilt devices and also arrangements for correcting the alignment to obtain balanced rotation. The turntable assembly is provided with a mercury or mechanical water seal at its base. The current trend is to discourage mercury seals because of the chances of causing mercury pollution. Facilities should be available for draining the central column of the flow distributor for attending to repairs and maintenance.

The distributor arms are generally two in number, multiples of two also being adopted. When multiple arms are provided, low flows are distributed through two arms only and as flow increases, it is distributed by the additional arms. This is achieved by overflows from weirs incorporated in the central column diverting the higher flows into the additional arms. The peak velocities in the distributor arms should not exceed 1.2 mps. The distributor arms are generally fabricated of steel and are liable to rapid corrosion. They should be fabricated and bolted together in such lengths as to facilitate dismantling for periodic repainting of their inside surfaces. The orifices in the distributor arms should be composed with aluminium orifice plates. Spreader plates, preferably of aluminium, should be provided below the orifices to spread out the discharge. The clearance between the distributor pipe and the top of the filter media should be greater than 15 cm.

Distributor arms should have gates at the end for flushing them. At least one end plate should have arrangement for a jet impinging on the side wall to flush out fly larvae. The distributor arms may be of constant cross section for small units but in larger units, they are tapered from the centre towards the end to maintain the minimum velocity required in the arms.

The distribution arrangements should ensure uniform distribution of the sewage over the filter surface for which the size and spacing of the orifices in the distributor arms have to be varied carefully from the centre towards the end. Under average flow conditions, the rate of dosing per unit area at any one point in a filter should be within $\pm 10\%$ of the calculated average dosing rate per unit area for the whole filter. The distributors should also ensure that the entire surface of the filter is wetted and no area is left dry.

Reaction type rotary distributors require adequate hydraulic head for operation. The head required is generally 1 to 1.5 m measured from the centre line of distribution arms to the low water level in the distribution well or the siphon dosing tank preceding the filter. Alternatively, the rotary distributor driven by electric motor may be used. This type is particularly advantageous where adequate head is not available. The speed of rotation of the distributors shall ensure that the intervals of successive dosings is between 15 and 20 seconds.

14.2.5 Multiple Units

In a single stage plant, it is advisable to split the required filter volume into two or more units so that when one filter is taken out of operation for maintenance or repairs, the entire sewage can be passed through the remaining units, overloading them temporarily.

In a two stage plant, if multiple units are proposed in each stage, the entire sewage may be routed through the remaining units of the stage when one filter in that stage is taken out of operation. However, the recirculation flow is maintained at the original level, operating the stage at a lower recirculation ratio. If, instead, only one filter is proposed for each stage a bypass should be provided for each stage. It is customary in the design of two stage filters to use two filters of equal size.

14.2.6 Plant Hydraulics

The feed pipe to the filter, the distributor, the underdrains and the main collection channel should be designed for the peak instantaneous hydraulic loading on the filter. In low rate filters, the peak loading will be the peak discharging capacity of the dosing siphon or the dosing pump. In the case of high rate filters, the peak loading on the filters will be the sum of the peak rate of sewage flow and the constant recirculation rate.

When multiple units are used for the high rate filters in any stage, the hydraulics of the plant should be checked for peak loading with one filter out of operation, the entire flow routed through the remaining units. A reduced recirculation ratio is adopted for this condition so as to reduce the peak loading and avoid oversizing of the piping.

When multiple units are used care should be taken to ensure that the flow is divided properly between the various filters.

14.2.7 Pumping Arrangements

In a high rate filter, pumping is required for recirculation. Pumping may also be required for lifting the filter effluent to the settling tank or to the next stage filter.

Except in the case of small plants, recirculation pumps should be installed in multiple units so that the recirculation rate can be changed as found necessary.

Pumps for lifting the flow-through sewage should have adequate capacity to pump the peak flows through the plant. The pumps should be installed in multiple units to take care of diurnal variations in flow which will approximately be the same as the sewage inflow to the plant. It will further be necessary to provide storage in the suction well equal to about 10 min of discharge capacity of the lowest duty pump. Float control arrangements are desirable in the suction well for controlling the number of pumps in operation.

In all the cases, at least one pump should be provided extra as a standby. Also, in the case of recirculation pumps, flow measuring and recording devices are desirable on the discharge line so that a record can be kept of the recirculation ratio actually employed in the plant.

14.2.8 Operational Problems

Ponding or clogging of the filter media is one of the important operational problems in trickling filters. Ponding decreases filter ventilation, reduces the effective volume of the filter and lessens filter efficiency. Ponding or clogging is due to excessive organic loading, inadequate hydraulic loading and inadequate size of media. Remedies consist of raking or forking the filter surface, washing the filter by applying a high pressure stream of water at the surface, stopping the distributor to allow continuous heavy point by point dosing or chlorinating the influent with a dose not exceeding 5 kg/100 m² of filter area.

Filter flies pose another serious operational problem in trickling filters. The problem is more intense in the case of low rate filters. In high rate filters fly breeding occurs mainly on the inside walls of the filter. The problem can be reduced by (a) removing excessive biological growth by the previously discussed methods (b) flooding the filter for 24 hours at weekly or biweekly intervals, (c) jetting down the inside walls of the filter with a high pressure hose, (d) chlorinating the influent (0.5 to 1.0 mg/l) for

several hours at one to two week intervals and (e) applying insecticides. The insecticide should be applied to the filter side walls and surface at intervals of 4-6 weeks. Development of resistant strains should be guarded against.

Filter odours also present a problem in trickling filter operation. Odours are most serious when treating septic effluents in low rate filters. Odours can be controlled by providing recirculation and maintaining a well ventilated filter.

In conditions of extreme cold weather, ice cover may form on the surface of the bed. Reduction of the recirculation flow, adjustment of nozzles or construction of wind breakers are methods used to reduce icing problems.

14.3 ROTATING BIOLOGICAL CONTACTOR

Rotating Biological Contactor (RBC) is one of the relatively recent addition to the family of biological treatment devices. It has been widely used abroad but not in India for the treatment of both industrial and domestic wastewaters, especially for small and medium-scale units. This is a relatively simple attached growth system operating on the principle of moving media. The RBC units can be adopted for small and medium towns.

The advantages claimed for RBC include (i) low food to microorganism ratio resulting in higher efficiencies of organic matter removal (ii) low hydraulic retention periods minimizing tank volume and capital costs (iii) low head loss and lower power requirements (iv) inherent simplicity and low operational and maintenance cost (v) ability to resist shock loads and (vi) ability to lend itself to modular fabrication to suit required effluent quality.

14.3.1 Process Description

The Rotating Biological Contactor unit consists of a series of closely spaced vertical discs mounted on a horizontal shaft rotating at slow speeds, normally less than 10 rpm, the movement of the discs being perpendicular to the wastewater movement in a cylindrical vessel. The discs, also called biodiscs, support biomass and are partially (40 - 60%) submerged in the wastewater. The rotation of the biodiscs causes the biomass to be alternatively submerged in wastewater to absorb food and to pick up a thin layer of wastewater and then raised out of the liquid into the air to oxidise the absorbed substrate and to allow the wastewater film to slide down the biomass. It has been suggested that the orthogonal rotational motion of biomass on discs relative to horizontal liquid movement results in ideal shear and turbulence conditions at solid - liquid interface to cause exceptionally high transfer of substrate and oxygen into biological slime and waste products from it.

Excess biomass growing on the disc surfaces is sheared off and sloughed biomass is kept in suspension by the mixing action of the discs and carried out of the cylindrical tank along with the effluent. Both the substrate utilisation within the microbial film and the sloughing of excess biomass are continuous processes which help in maintaining a constant thickness of microbial film on the discs. Thickness of biofilm may reach upto 2 to 4 mm depending upon the strength of wastewater and rotational speed of the discs.

The basic process flow sheet of wastewater treatment system may consist of primary sedimentation following screening and grit removal, aerobic biological treatment in RBC unit and secondary settling for solid - liquid separation of sloughed film from treated wastewater. The settled sludge from primary and secondary sedimentation has to be suitable treated and disposed.

14.3.2 Constructional Features

The RBC unit essentially consists of

- i) cylindrical bottomed horizontal flow tank usually divided into an appropriate number of

stages which are hydraulically connected. The tank may be constructed of steel, fibre glass, concrete or masonry.

- ii) circular discs of PVC, asbestos cement or any inert light material of high durability mounted on shaft of sufficient rigidity. The disc diameters usually vary between 1 to 4 m and thickness upto 10 mm.
- iii) A driving mechanism comprising of a motor and a reduction gear.

A reactor module consists of a tank with circular discs mounted on a shaft driven by motor through reduction gear. Several modules may be arranged in parallel and/or in series to meet the flow and effluent quality requirements.

14.3.3 Design And Operational Parameters

Several process parameters affect the performance of RBC as a biological treatment device. Some of the important parameters include (i) hydraulic loading (ii) hydraulic retention time (iii) influent substrate loading (iv) disc rotational speed (v) disc area available for biological growth and (vi) disc submergence.

The hydraulic loading rates vary depending upon the influent substrate concentration and desired quality of effluent, with typical value around 110 litres per day per sq.m. of surface area of the discs for primary settled domestic wastewater. The corresponding organic loading may be 0.022 Kg BOD₅/sqm of surface area/Day for BOD₅ of 200 mg/l for primary settled wastewater. The hydraulic retention period of 1 to 1.5 hr. can result in 90% BOD removal efficiency. The disc rotational speed usually varies from 2 to 6 rpm. The disc submergence is usually between 40 and 60%.

Reductions of 90 % in BOD and SS could be expected at detention periods of 1 - 1.5 hours in the disc chamber and about one hour in the settling basin. The energy consumption varies from 0.6 to 1.2 kWh per kg. of BOD removed with a loss of head of less than 2.5 cm through the unit. This energy consumption corresponds to about 6.6 to 13.2 kwh per person per year in comparison to 10-16 kwh/person/year for other biological treatment units like ASP, oxidation ditch or lagoons.

STABILIZATION PONDS

Stabilization ponds are open, flow-through earthen basins specifically designed and constructed to treat sewage and biodegradable industrial wastes. Stabilization ponds provide comparatively long detention periods extending from a few to several days. During this period putrescible organic matter in the waste is stabilized in the pond through a symbiotic relationship between bacteria and algae. Pond systems, in which oxygen is provided through mechanical aeration rather than algal photosynthesis are called aerated lagoons. These are discussed in chapter 13. Lightly loaded ponds used as tertiary step in waste treatment for polishing of secondary effluents and removal of bacteria are called maturation ponds.

Under many situations in warm climate countries pond systems are cheaper to construct and operate compared to conventional methods. They also do not require skilled operational staff and their performance does not fluctuate from day to day. The only disadvantage of pond systems is the relatively large land that they require, but this is sometimes over-emphasized. In addition, land on the outskirts of a growing city can be a worthwhile investment. Pond systems must be considered as an alternative when treatment of wastewater or upgrading of existing facilities are planned and the life time costs of various other treatment system should be calculated and compared

15.1 CLASSIFICATION

15.1.1 Aerobic

Aerobic ponds are designed to maintain completely aerobic conditions. They are used for soluble wastes (primary effluent) which allow penetration of light throughout the liquid depth. The ponds are kept shallow with depth less than 0.5 m and BOD loadings of 40-120 kg/ha.d. The pond contents may be periodically mixed. Such ponds develop intense algal growth and have been used on experimental basis only.

15.1.2 Anaerobic

Completely anaerobic ponds are used as pretreatment for high strength industrial wastes and sometimes for municipal wastewaters. They are also used for digestion of municipal sludges. Depending on temperature and waste characteristics, BOD load of 400-3000 kg/ha. d and 5-50 day detention period would result in 50-85 percent BOD reduction. Such ponds are constructed with a depth of 2.5-5m to conserve heat and minimize land area requirement. Usually they have an odour problem.

15.1.3 Facultative

The facultative pond functions aerobically at the surface while anaerobic conditions prevail at the bottom. The aerobic layer acts as a good check against odour evolution from the pond. The treatment effected by this type of pond is comparable to that of conventional secondary treatment processes. The facultative pond is hence best suited and most commonly used for treatment of sewage. The discussion in this Chapter is, therefore, confined to facultative ponds

15.2 MECHANISM OF PURIFICATION

The physical, chemical and biological reactions in engineered pond systems are controlled by the design criteria. The functioning of a facultative stabilization pond and symbiotic relationship in the pond are shown schematically in Fig.15.1. Sewage organics are stabilized by both aerobic and anaerobic reactions. In the top aerobic layer, where oxygen is supplied through algal photosynthesis, the non-settleable and dissolved organic matter in the incoming sewage is oxidized to carbon dioxide

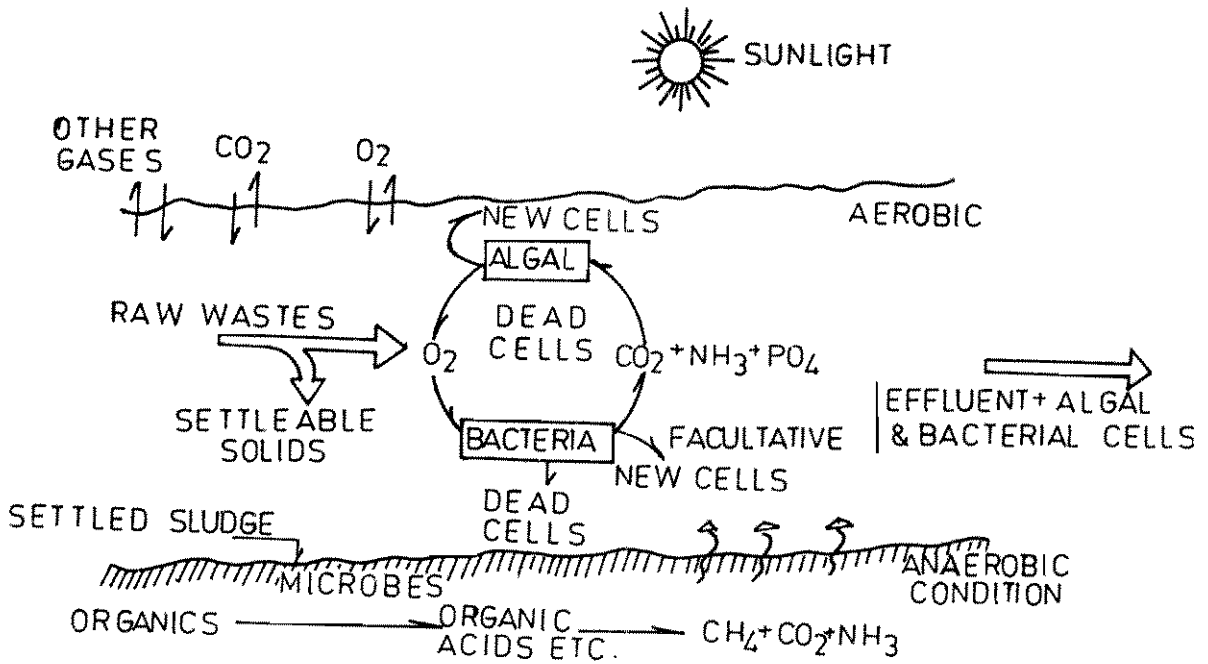
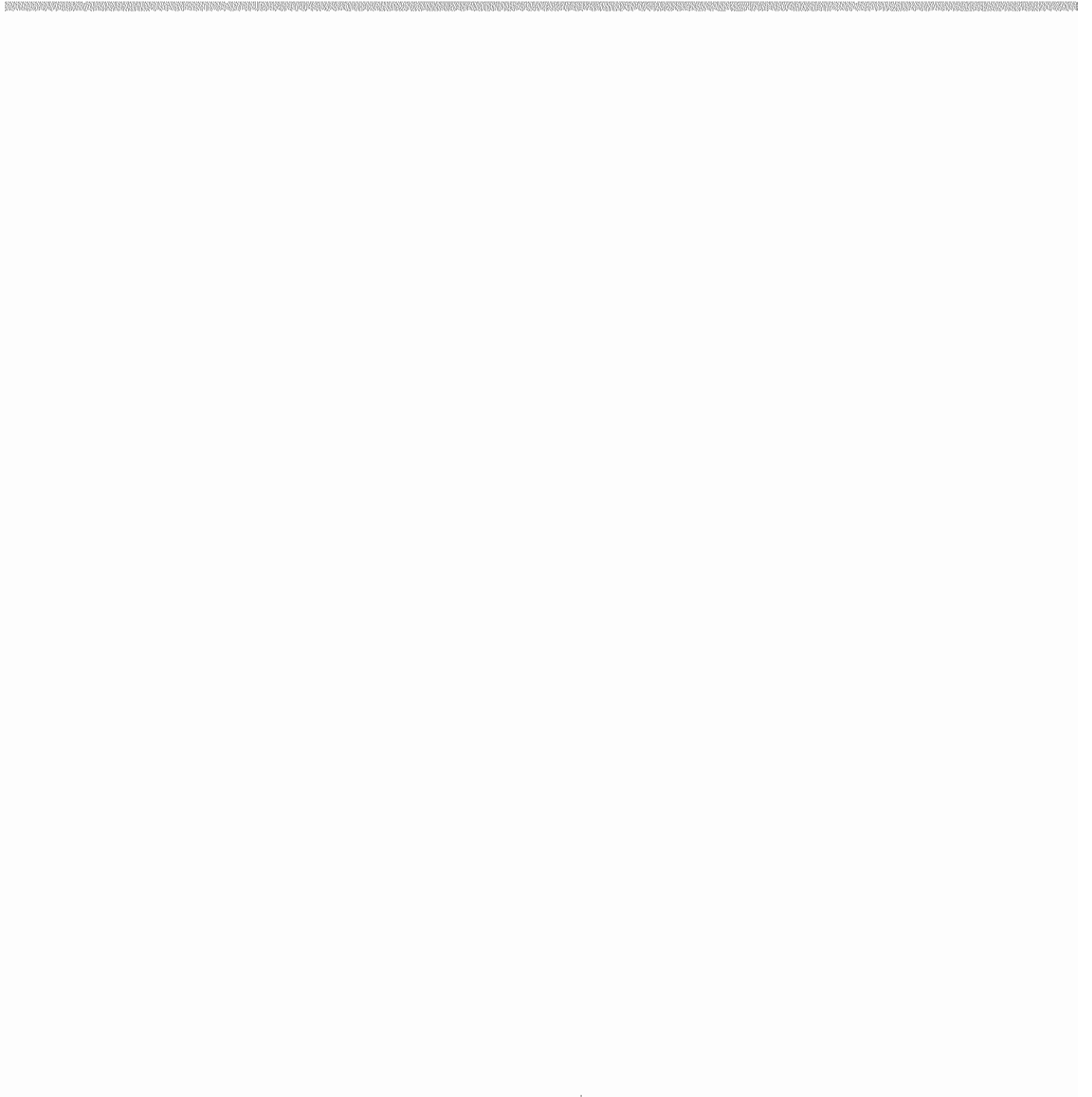

FIG. 15.1: SYMBIOTIC RELATIONSHIP AND FUNCTIONING OF A FACULTATIVE STABILIZATION POND.



and water. In addition, some of the end products of partial anaerobic decomposition such as volatile acids and alcohols, which may permeate to upper layers are also oxidized aerobically. The settled sludge mass originating from raw waste and microbial synthesis in the aerobic layer and dissolved and suspended organics in the bottom layers undergo stabilization through conversion to methane which escapes the pond in form of bubbles. For each kg of BOD-ultimate stabilized in this manner, 0.25 kg or 0.35 m³ of methane is formed. Another reaction which sometimes occurs in the anaerobic layers is conversion of hydrogen sulphide to sulphur by photo-synthetic bacteria. If present in sufficient numbers they give a distinct pink hue to the pond appearance.

15.2.1 Aerobic and Anaerobic Reactions

The depth of aerobic layer in a facultative pond is a function of solar radiation, waste characteristics, loading and temperature. As the organic loading is increased, oxygen production by algae falls short of the oxygen requirement and the depth of aerobic layer decreases. Oxygen diffusing from top layers is quickly and completely utilized. Further, there is a decrease in the photo-synthetic activity of algae because of greater turbidity and inhibitory effect of higher concentration of organic matter.

Gasification of organic matter to methane is carried out in distinct steps of acid production by acid forming bacteria and acid utilization by methane bacteria. Production of methane is fundamental to BOD reduction by anaerobic metabolism. If the second step does not proceed satisfactorily there is an accumulation of organic acids in the pond bottom which diffuses towards the top layers. Further more, under such conditions the pH of the bottom layers may go down. This would result in complete inhibition of methane bacteria and the pond may turn completely anaerobic due to accumulation of end products of partial anaerobic decomposition. Imbalance between the activities of the two sets of microorganisms in a pond may result from two possible reasons. The waste may contain inhibitory substances which would retard the activity of methane producing organisms and not affect the activity of acid producers to the same extent. In treatment of domestic or municipal wastewater such a condition, however, would rarely arise. The other reason for the imbalance may be a fall in temperature of the pond. The activity of methane bacteria decreases much more rapidly with decreasing temperature as compared to the acid formers and gas production stops at temperatures lower than 15 degree C. Thus, year round warm temperatures and sunshine provide an ideal environment for operation of facultative stabilization ponds.

15.2.2 Diurnal Variations

Both the dissolved oxygen and pH of the pond are subject to diurnal variation due to photosynthetic activity of algae which is related to incident solar radiation. A high dissolved oxygen concentration upto about 4 times the saturation value may be observed in the afternoon hours. Simultaneously, the pH value may reach a maximum of 9.0 or more due to the conversion of carbon dioxide to oxygen. Towards the evening or in the night, when photosynthetic activity decreases or stops, there is a gradual decrease in both dissolved oxygen and pH. In properly designed ponds, the dissolved oxygen does not completely disappear from the top layers at any time. The increase of pH is beneficial as it increases the die off rate of faecal bacteria.

15.2.3 Odour Control

In a facultative pond, the nuisance associated with anaerobic reactions is eliminated due to the presence of oxygen in the top layers. The foul smelling end products of anaerobic degradation which permeate to the top layers are oxidised in an aerobic environment. Further more, due to a high pH in top layers, compounds such as organic acids and hydrogen sulphide, which would otherwise volatilise from the surface of the pond and cause odour problems, are ionised and held back in solution.

15.2.4 Algae

In stabilization ponds, the significant algae are green algae which include *Chlorella*,

Scenedesumus, Hydrodictyon Chlamydomonas and Ankistrodesmus and blue-green algae which include Oscillatoria, Spirulina, Merismopedia and Anacystis. Chlorella, Scenedesmus and Hydrodictyon possess relatively high oxygen donation capacity per unit weight. However, it is not practical to promote the growth of any particular type of algae in a pond which will depend on such factors as temperature, characteristics of the waste and intensity of sunlight. Concentration of algae in a stabilization pond is usually in the range of 100-200 mg/l which gives the pond effluent a typical green colour. Floating blue-green algae mats may develop in ponds during summer months. They are undesirable since they restrict penetration of sunlight leading to reduction in depth of aerobic layer. They also encourage insect breeding.

15.3 DESIGN CONSIDERATIONS

From the foregoing discussion it is apparent that a rational design of pond should take into consideration requirements of both aerobic and anaerobic mechanisms of stabilization of organic matter. It is, however, difficult to determine the fraction of the incoming BOD load which should be taken to be stabilized aerobically and predict the loading rate at which a 'protective' aerobic layer would be maintained. The facultative pond system, though simple to operate, is a complex ecosystem which escapes a quantitative definition. It is only on the basis of experience and understanding of the reactions that one can lay down rational criteria.

15.3.1 Areal Organic Loading

The permissible areal organic loading for the pond expressed as kg BOD₅/ha.d will depend on the minimum incidence of sunlight that can be expected at a location and also on the percentage of the influent BOD that would have to be satisfied aerobically. Many different methods have been developed for determining the permissible area loading. Two methods are discussed here.

- (a) The Bureau of Indian Standards has related the permissible loading to the latitude of the pond location to aerobically stabilize the organic matter and keep the pond odour free (Refer IS:5611)

The recommended loading rates are as below:

TABLE 15.1
PERMISSIBLE ORGANIC LOADINGS AT DIFFERENT LATITUDES

Latitude (N) degree	Organic loading Kg BOD ₅ /ha.d
36	150
32	175
28	200
24	225
20	250
16	275
12	300
8	325

The recommended BOD loadings are for municipal sewage and are inclusive of the BOD of the settleable solids in the wastes. The values are applicable to towns at sea levels and where the sky is clear for nearly 75% of the days in a year.

The values of organic loading given in Table 15.1 may be modified for elevations above sea level by dividing by a factor of $(1+0.003 \text{ EL})$ where EL is the elevation of the pond site above MSL in hundred meters. An increase in the pond area has to be made when the sky is clear for less than 75% of the days. For every 10% decrease in the sky clearance factor below 75%, the pond area may be increased by 3%.

Another design approach, based on field experience in warm climates relates the permissible area BOD loading to the ambient temperature on the assumption that temperature would depend on solar radiation:

$$L_o = 20T - 120 \quad (15.1)$$

Where L_o = design organic load, kg BOD₅/ha. d and T = average temperature during coldest month of the year, 0° C.

The designs based on the two methods given above, as well as other methods developed empirically, wherever possible should be checked against field experience in the region. When the ponds are intended to serve small communities or when they are located close to residences, it will be prudent to adopt lesser BOD loading so as to fully ensure absence of odours.

15.3.2 Detention Time and Hydraulic Flow Regimes

The flow of sewage through a pond can approximate either plug flow or complete mixing, which are two extreme or ideal conditions. If BOD exertion is described by a first order reaction, the pond efficiency is given by:

For Plug flow

$$\frac{L_e}{L_i} = e^{-K_d t} \quad (15.2)$$

for Complete Mixing

$$\frac{L_e}{L_i} = \frac{1}{1 + K_d t} \quad (15.3)$$

Where L_i and L_e = influent and effluent BOD respectively, t = detention time, and k_d = BOD reaction rate constant. The value of k_d varies between 0.05 and 0.2 per day and is independent of temperatures above 15 degree C. The lower values were determined for secondary and tertiary ponds.

In practice the hydraulic regime lies between the two regime and is described as dispersed flow. The efficiency of treatment for different degrees of intermixing, characterized by dispersion numbers, can be determined as given in section 13.8 for aerated lagoons.

Dispersion numbers are determined by tracer studies. Dispersion numbers for stabilization ponds vary from 0.3 to 1.0. Choice of a larger value for dispersion number or assumption of complete mixing would give a conservative design and is recommended.

15.3.3 Depth

Having determined the surface area and detention capacity or volume of a pond, it becomes necessary to consider the depth of the pond only in regard to its limiting values. Shallow depths in facultative ponds will allow growth of aquatic weeds in the ponds. The optimum range of depth for facultative ponds is 1.0 - 1.5 m. When depth determined from area and detention period works out lesser than 1.0m, the depth should be increased to 1.0 m, keeping surface area unchanged.

15.3.4 Sludge Accumulation

The rate of sludge accumulation in facultative ponds depends primarily on the suspended solids concentration in the influent wastes. The reported rate of sludge accumulation in ponds treating municipal sewage ranges from 0.05 to 0.10 m³/capita/year. A value of 0.07 m³/capita/year forms a reasonable assumption in design. In multiple cell ponds operated in series, most of the sludge accumulation will be in the primary cells.

Continued sludge accumulation in ponds over many years will cause (i) sludge carryover into the effluent, (ii) development of aquatic weeds, and (iii) reduction in pond efficiency due to reduction in the detention period. Facultative ponds therefore require periodical desludging at intervals ranging from 6 to 12 years.

15.3.5 Bacterial Reduction

Bacterial reduction in ponds is analogous to BOD reduction described in 15.3.2 above, except the BOD reduction rate constant is replaced by bacterial dieoff constant, K_b and inputs and outputs are in terms of bacterial concentrations N_i and N_e respectively. It is customary to use completely mixed conditions when calculating bacterial reduction. This gives a conservative design. Overall bacterial reduction in 'n' ponds of equal detention time 't' in series is given by

$$\frac{N_e}{N_i} = \frac{1}{(1+K_b t)^n} \quad (15.4)$$

A commonly used value of K_b for fecal bacteria at 20 degree C is 2.0 per day. The value of K_b at other temperatures may be calculated by:

$$K_{b,T} = k_{b,20} (1.19)^{1.04(T-20)} \quad (15.5)$$

where $K_{b,T}$ and $K_{b(20)}$ are values of the constant at T and 20° C respectively.

15.4 CONSTRUCTION DETAILS

15.4.1 Site Selection

Facultative pond sites should be located as far away as practicable (at least 200m) from habitations or from any area likely to be built up within a reasonable future period. If practicable the pond should be located such that the direction of prevailing wind is towards uninhabited areas. The pond location should be downhill of ground water supply source to avoid their chemical or bacterial pollution. Special attention is required in this regard and in porous soils and in fissured rock formations.

The pond site should not be liable to flooding. Wherever possible, the elevation of the site should permit the pond to discharge the effluent by gravity to the receiving streams. The site should preferably allow an unobstructed sweep of wind across the pond, open to the sun and not shaded by trees. Advantages should be taken of natural depressions while locating the ponds.

15.4.2 Pretreatment

It is desirable to provide medium screens and grit removal devices before facultative ponds.

15.4.3 Construction in Stages

In cases where the design flow will materialise only in the course of time, it is important to design facultative ponds in multiple cells and construct the cells in stages. Otherwise, the small flows in the initial years may not be able to maintain satisfactory water levels in the ponds and objectionable weed growths and mosquito breeding may develop in the installations.

Construction in stages will also reduce initial costs and help in planning future stages based on the performance data of first stage.

15.4.4 Multiple Units

Multiple cells are recommended for all except small installations (0.5 ha or less). Multiple cells in parallel facilitate maintenance as any one unit can be taken out of operation temporarily for desludging or repairs without upsetting the entire treatment process. The parallel system also provides better distribution of settled solids.

Multiple cells in series decrease dispersion number and enable better BOD and coliform removal and reduced algal concentration in the effluent. The series system implies a high BOD loading in the primary cells and to avoid anaerobic conditions in these cells, they should have 65-70% of the total surface area requirements.

A parallel series system possess the advantages of both parallel and series operations. A convenient arrangement for this system consists of three cells of equal area, of which two are in parallel and serve as primary ponds and the third serves as secondary pond in series. Individual cell should not exceed 20 ha in area.

15.4.5 Pond Shape

The shape should be such that there are no narrow or elongated portions.

Rectangular ponds with length not exceeding three times the width are to be preferred. Maximum basin length of 750 m is generally adopted. The corners should always be rounded to minimise accumulations of floating matter and to avoid dead pockets.

15.4.6 Embankment

Ponds are usually constructed partly in excavation and partly in embankment. The volume of cutting and the volume of embankment should be balanced to the maximum extent possible in order to economise construction costs.

Embankment materials usually consist of material excavated from the pond site. The material should be fairly impervious and free of vegetation and debris. The embankment should be compacted sufficiently. The top width of the embankment should be atleast 1.5 m to facilitate inspection and maintenance.

The free board should be at least 0.5 m in ponds less than 0.5 ha in area. In larger installations, the free board should be designed for the probable wave heights and should be at least 1.0m.

Embankment slopes should be designed based on the nature of soil, height of embankment and protection proposed against erosion. Outer slopes are generally 2.0-2.5 horizontal to 1 vertical.

Inner slopes are made 1.0-1.5 when the face is fully pitched and flatter, 2.0-3.0, when the face is unprotected. Inner slopes should not exceed 4 as flatter slopes create shallow areas conducive to the growth of aquatic weeds.

The outer faces of the embankments should be protected against erosion by turfing. The inner faces should preferably be completely pitched to eliminate problems of erosion and growth of marginal vegetation. Pitching may be by rough stone revetment or with plain concrete slabs or flat stones with adequate gravel packing. When complete pitching is not possible, at least partial pitching from a height 0.3m above water line to 0.3m below water line is necessary and the face above the line of pitching should be turfed to the top of embankment.

15.4.7 Pond Bottom

The pond bottom should be level, with finished elevations not more than 0.10 m from the average elevation. The bottom should be cleared of all vegetation and debris. The soil formation of the bottom should be relatively impervious to avoid excessive liquid losses due to seepage. Where the soil is loose, it should be well compacted. Gravel and fractured rock areas must be avoided.

15.4.8 Pond Inlets

The pipeline conveying raw sewage to the pond, whether by gravity or by pumping, should be terminated in a flow measuring chamber located close to the pond. There should be sufficient fall from the measuring chamber to the pond surface so that the measuring weir may not be submerged. If the pond installation is in multiple parallel cells, the measuring chamber should have flow splitting provision and there should be separate pipeline to each cell. The size of the pipeline may be designed to maintain an average velocity of 0.3m/s. The pipeline should be semi-flexible and should be properly supported inside the pond.

In case the pond cell is large, multiple inlets should be provided along the inlet side of the pond at the rate of one for every 0.5 to 1.0 hectare of pond area. This requirement applies also to outlets. In case the pond is small, a single inlet and a single outlet will be sufficient. The inlets in the pond shall be so located as to avoid short-circuiting of flow to the outlets. The inlets should not be upwind of the outlets and should be extended into the pond for one-third to one-fourth the pond length or 15 to 20 m, whichever is less. The discharge may be horizontal and at half depth. A concrete apron of adequate size should be provided under the discharge to prevent erosion of pond bottom, especially when the pond is getting filled up.

15.4.9 Pond Outlets

Multiple outlets are desirable except in small ponds and may be provided at the same rate as for inlets, one for every 0.5 ha pond area. The outlets should be so located with reference to the inlets as to avoid short circuiting. The outlet structures may consist either of pipes projecting into the ponds or weir boxes. In the former case vertical tees and in the later case hanging baffles submerged to a depth of 0.25 m below the water surface should be provided to ensure that floating algal scum is not drawn along with the effluent.

When the outlet structure is a weir box, it is desirable to provide adjustable weir plates so that the operating depth in the pond can be altered if required. Where the pond effluent is to be used for farming and involves pumping, the outlet pipe should be led to a sump of adequate capacity (30 minutes at the rate of pumping). All piping should be provided with suitable valves to facilitate operation and maintenance.

15.4.10 Pond Interconnections

Pond interconnections are required when ponds are designed in multiple cells series. These interconnections should be such that the effluent from one cell withdrawn from the aerobic zone can

be introduced at the bottom of the next cell. Simple interconnections may be formed by pipes laid through the separating embankments. At their upstream ends, the interconnecting pipes should be submerged about 0.25 m below the water level. The downstream ends may be provided with a bend, facing downward, to avoid short circuiting by thermal stratification, care being taken to prevent erosion of the embankment.

15.4.11 Other Aspects

Provision should be made for flow measurement both at inlet and outlet of the ponds. Wherever practicable, facilities should be available to drain out the pond completely by gravity through a sluice arrangement. The pond site should be fenced to prevent entry of cattle and discourage trespassing. Public warning boards should also be put up near the ponds clearly indicating that the pond is a sewage treatment facility.

15.5 OPERATION AND MAINTENANCE

In commissioning a pond, the sewage should be allowed to fill the pond gradually to a depth of about 30 cm and this level maintained by admitting periodically, a small quantity of raw sewage. Algal growth will establish itself naturally, without requiring any artificial seeding. After the first algal bloom has established itself which may take a week or two, further raw sewage is admitted gradually at a rate not exceeding the design rate until the entire pond is filled up. The pond is then allowed to rest for two to three days to ensure that the algal growth has fully established. The pond at this stage is ready for continuous inflow of sewage.

Once the pond is in normal operation, the effluent and influent piping should be inspected daily to check that they are not blocked. The pond embankments should be inspected periodically to examine whether there is any damage to them by burrowing animals.

It is very important to ensure that weeds and grass do not grow from the bank into the water. The environment in a facultative pond is not conducive to mosquito breeding; but, if there is vegetation at the water line, sheltered pockets will harbour mosquito larvae and a serious health and nuisance problem may arise. Where the inside slopes of the embankments are fully lined, there will be no growth of marginal vegetation and little attention will be required for its control.

In summer months, blue green algae may grow vigorously in the ponds giving rise to floating mats of algae. The algae in the mats may then die and give rise to odours. The algal mats may also attract flies. The growth of algal mats should therefore be controlled by frequent removal in the case of small ponds and by breaking up the mat from a boat and allowing them to sink in the case of large ponds.

Facultative ponds require desludging at long intervals when sludge has accumulated to an extent effecting pond performance. Desludging may be done by emptying the pond upto the top level of the sludge and allowing the sludge to dry out in the sun. The dried sludge can be removed and sold as solid conditioner. Adequate thought should be given even at the time of design and construction of the ponds to the method of desludging that will be adopted. In multicell serial ponds, desludging may be required only in the first pond.

15.6 PERFORMANCE

The algae in the pond effluent will exert BOD in the standard laboratory BOD test involving darkroom incubation and will also give high SS values. The BOD and SS values may each be in the range of 50-100 mg/l. However, the effluent will not cause nuisance when disposed of on land or discharged into receiving waters because the algal cells do not readily decompose or exert oxygen demand under natural conditions. In fact, the algae increases the oxygen levels in the receiving water by continued photosynthesis.

Because of the above reasons, the standard BOD and SS tests are not considered useful for evaluating the quality of facultative pond effluents. The quality is usually assessed based on the BOD₅ of the filtered effluent, the assumption being that the suspended solids in the effluent are all algae. The filtration procedure adopted for the test is the same as for the suspended solids test.

Well designed facultative ponds give about 80-90% BOD reduction based on the filtered BOD₅ of the effluent.

Facultative ponds also effect high bacterial reduction, the efficiency being particularly high in multicell ponds operated 'in series'. Coliform and faecal streptococci removals are as high as 99.99%. Intestinal pathogens belonging to Salmonella and Shigella groups are reported to be completely eliminated in stabilisation ponds. Cysts of Entamoeba histolytica and helminthic larvae are also eliminated.

15.7 APPLICATIONS

The facultative pond is simple and cheap to construct. It does not require skilled operation and is easy to maintain. Properly designed, the pond also gives consistently good performance. The facultative pond has therefore become very popular for municipal and institutional sewage treatment. The method is suited wherever land is cheap and readily available and may be used for treating sewage either for discharge into streams or lakes or for use on land. The effluent from stabilization pond may be used for pisciculture. The method is particularly useful for interim sewage treatment when due to lack of funds or due to meagre flow in the initial stages, it is considered inexpedient to construct initially the treatment plant envisaged ultimately.

The facultative pond is also suited for the treatment of industrial wastes which are biodegradable provided the wastes are not coloured and do not contain substances toxic to algae.

Because of high level of performance in terms of pathogen removal and reliability, effluents from ponds having a minimum detention time of 4-6 days can be safely used for irrigation for crops which are not to be eaten raw. For unrestricted irrigation, series of pond systems may be designed to meet the microbial quality criteria for irrigation water.

ANAEROBIC TREATMENT OF WASTEWATERS

16.1 INTRODUCTION

Anaerobic treatment of wastewaters has a number of advantages over aerobic treatment processes, namely, the energy input of the system is low, as no energy is required for oxygenation, lower production of excess sludge (biological synthesis) per unit mass of organic matter stabilized, lower nutrient requirement due to lower biological synthesis and the degradation of waste organic material leads to the production of biogas which is a valuable source of energy.

Anaerobic digestion as a unit process in municipal wastewater treatment has been in use since the beginning of this century. It is employed for stabilization of sludge solids from primary and secondary sedimentation tanks either in closed digesters or open lagoons. Anaerobic lagoons are also used for treatment of industrial wastes. Conventionally the anaerobic process is considered a slow process requiring digesters of large hydraulic retention time (HRT).

In recent years a number of high rate systems have been constructed to treat concentrated liquid industrial wastes and for direct treatment of municipal wastewater. Application of anaerobic treatment technology for treatment of municipal waste water has special significance in India because of high energy savings and low capital and OM & R costs. This chapter briefly reviews various high rate systems and summarizes the available design criteria. It also lists aspects of anaerobic treatment which must be evaluated in the designs.

16.2 HIGH RATE ANAEROBIC SYSTEMS

High rates of conversion of organics into methane can be obtained by maintaining a high concentration of microorganisms in a reactor and preventing them from escaping with the effluent. This concept is expressed as Sludge Retention Time (SRT). The SRT is defined as the ratio of mass of biological solids in the system to that escaping from the reactor. Maximal SRT is desirable for process stability and minimal sludge production. Minimal HRT minimizes the reactor volume and thus reduces capital costs. Other requirements of high rate systems are intimate contact between incoming waste and the biological solids and maintenance of sufficiently warm temperatures. Fig.16.1 schematically shows basic configurations of high rate anaerobic systems.

16.2.1 Anaerobic Contact Process

The Anaerobic Contact (AC) process. Fig.16.1 (a), is a stirred tank reactor in which the biomass leaving with the reactor effluent is settled in a sedimentation tank and recycled, thus increasing SRT. The settling of the anaerobic sludge may at times be a limiting factor. Biomass separation may be improved using parallel plate separators. The process lends itself to concentrated wastes containing refractory suspended matter. Continuous and complete mixing in the reactor is not recommended since this may adversely affect settling characteristics of the sludge. On the other hand, inadequate mixing may result in formation of dead zones inside the reactor. This process has been used for treatment of industrial wastewaters.

16.2.2 Anaerobic Filter

In Anaerobic Filter (AF) Fig.16.1(b), microbial cells are both entrapped as clumps of cells in the interstices between packing material and as biofilm attached to the surface of the packing material.

The packing or filter media is usually of naturally crushed rock of 15 to 25mm size or consisting of plastic or ceramic material. The filter media should have high specific surface and porosity to allow for maximum possible film growth and retention of biomass. The reactor is operated as upflow submerged packed bed reactor. A number of such filters have been constructed for treatment of low strength wastes such as municipal wastewater.

16.2.3 Anaerobic Fixed Films Reactor

In Anaerobic Fixed Film (AFF) Reactor, Fig.16.1 (c), the microbial mass is immobilized on fixed surfaces in the reactor. It is operated in downflow mode to prevent accumulation of refractory particulates contained in the influent and sloughed biofilm. The sloughed biofilm is also discharged with the effluent. The reactor may be operated in either submerged or unsubmerged condition. The reactor packing is usually of modular construction consisting of plastic sheets providing a high void ratio. Such reactors have been constructed to treat high strength wastes.

16.2.4 Fluidized and Expanded Bed Reactor

The Fluidized Bed (FB) reactor, Fig.16.1(d), incorporates an upflow reactor partly filled with sand or a low density carrier such as coal or plastic beads. A very large surface area is provided by the carrier material for growth of biofilm. The system readily allows passage of particulates which could plug a packed bed, but requires energy for fluidization. Expanded Bed (EB) reactors do not aim at complete fluidization and use a lower upflow velocity resulting in lesser energy requirement. These reactors can be used for treatment of municipal wastewater as well.

16.2.5 Upflow Anaerobic Sludge Blanket Reactor

The Upflow Anaerobic Sludge Blanket Reactor (UASB), Fig.16.1(e), maintains a high concentration of biomass through formation of highly settleable microbial aggregates. The wastewater flows upwards through a layer of sludge. At the top of the reactor phase separation between gas-solid-liquid takes place. Any biomass leaving the reaction zone is directly recirculated from the settling zone. The process is suitable for both soluble wastes and those containing particulate matter. The process has been used for treatment of municipal wastewater at few locations and hence limited performance data and experience is available presently.

16.3 DESIGN AND OPERATIONAL CONSIDERATIONS

16.3.1 Organic Load and Sludge Retention Time

It is customary to express the organic matter in wastewaters in terms of Biochemical Oxygen Demand (BOD) or Chemical Oxygen Demand (COD). In anaerobic treatment systems, the COD value is finding greater usage which lends itself directly to mass balance calculations. Reduction in COD for municipal wastewater would normally correspond to equivalent amount of ultimate BOD reduction. Table 16.1 summarizes volumetric organic loads used in some of reactors for municipal wastewaters.

TABLE 16.1

ORGANIC LOADINGS AND PERFORMANCE EFFICIENCIES OF SOME HIGH RATE ANAEROBIC REACTORS

Reactor Type	Organic Load kg COD/m ³ . d	Efficiency %
AF	0.3 - 1.2	65 - 75
UASB	1.0 - 2.0	50 - 70

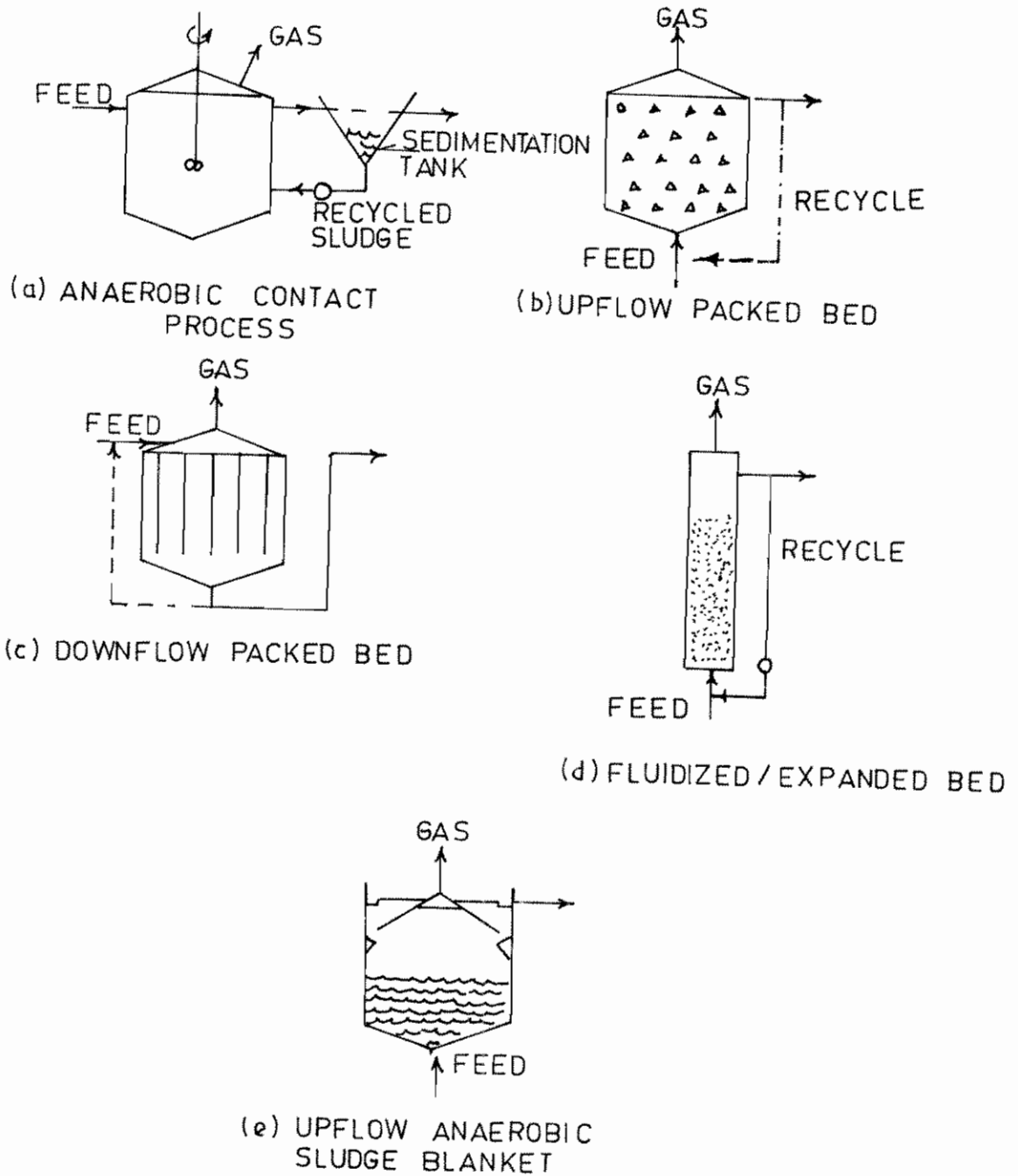

FIG.16.1: BASIC CONFIGURATIONS OF HIGH RATE ANAEROBIC SYSTEMS

SRT which is a more rational design parameter is difficult to calculate for anaerobic reactors. For AC and UASB it ranges between 15 to 30 days while for other systems it is estimated to be about 100 days or more giving them greater operational stability.

16.3.2 Hydraulic Load

For dilute wastes, the minimum HRT at average flow may be 6 to 12 h for wastes containing suspended organic matter. In UASB reactors where a settling zone is provided, the average hydraulic over flow rate should not exceed 1 m/h for flocculent sludge and 3 m/h for granular sludge. The velocity through port between reaction zone and settling zone for the two types of sludges should not exceed 3 and 12 m/h respectively. The face velocities for FB/EB reactors depend on the characteristics of the media used.

16.3.3 Effect of Temperature

Activity of methanogenic bacteria is strongly influenced by temperature. It approximately doubles for every 10° C rise in temperature in the range of 18° to 38° C. However, high micro-organism concentration in high rate anaerobic reactor compensates the decreased activities of the anaerobic organisms at lower temperature.

16.3.4 Excess Sludge production and Nutrient Requirement

In UASB treatment systems directly treating municipal wastewater the sludge production is reported to be 0.1 to 0.2 Kg dry matter/m³ wastewater treated or 0.4 to 0.7 kg dry matter/kg BOD removed. The sludge is well stabilized and dries directly on sand bed. The above reported quantity includes both inert matter present in waste and biological synthesis. The sludge production due to microbial synthesis from anaerobic systems is of the order of 0.01 to 0.1 kg VSS/kg COD removed. The lower values are for systems maintaining high SRT values. Consequently, the requirement of nitrogen and phosphorus is also low. In addition to nitrogen and phosphorus, methanogenic bacteria also require iron, cobalt, nickel and sulphide. These elements are usually present in municipal wastes but may have to be added to an industrial waste before it can be treated anaerobically.

16.3.5 Toxicity

A number of compounds which may be present in industrial wastes are reported to be toxic to methanogenic organisms. Anaerobic bacteria like most micro-organisms can be acclimated to different levels of various toxicants. However, because of their slow growth rate the acclimatization period may be comparatively longer. Industrial wastewaters should be evaluated for their toxic effects before anaerobic treatment is adopted.

16.3.6 Recirculation

Recirculation may be practiced for dilution of incoming waste organic matter and/or biodegradable toxicants. It also provides flow for fluidization in case of FB/EB reactors. In case of municipal wastewater, no recirculation is required except for fluidization in FB/EB reactors.

16.3.7 Gas Yield and Utilization

Methane production can be directly related to degree of treatment on the basis of COD value of methane produced and COD reduction. Theoretically 0.35 m³ methane is produced per kg COD reduction. Biogas contains 65-70% methane and 30-35% carbon dioxide. Since for low strength wastes there is considerable through put of liquid in a high rate anaerobic treatment system, the gases also escape from the system with the effluent in soluble form. For municipal wastewater, therefore, only 0.15 to 0.2 m³ methane/kg COD removed may be recovered. Further, because of considerably higher solubility of carbon dioxide in comparison to methane, the off gas is enriched in its methane content to about 90%.

The generation of biogas is considered an asset of anaerobic wastewater treatment. It is true for anaerobic digestion of sludges and strong industrial wastes where large amounts of gas may be generated. However, in the case of "weak" municipal wastewater the recovery is less. Furthermore, for financial viability there should be an opportunity for utilization of the gas. Direct use of biogas in boiler houses in industries, utilization in institutions or in house-holds is a more attractive option compared to generation of electricity which requires greater initial investment and operational and maintenance cost.

16.4 PRETREATMENT

Screening and grit removal are commonly used pretreatment unit operations for direct anaerobic treatment.

16.5 EFFLUENT QUALITY AND POST TREATMENT

In the case of treatment of municipal wastewaters, the effluent BOD can be expected to be about 50 mg/l assuming influent BOD of 200 mg/l. For concentrated wastes the BOD concentration would be higher. Depending on the situation, one or more of the following post-treatment operations may be considered:

- i) Holding pond of one day detention time followed by Fish pond/aqua culture pond
- ii) Aerobic treatment (aerated lagoons, oxidation pond, etc.)

SLUDGE THICKENING DEWATERING, DIGESTION AND DISPOSAL

17.1 INTRODUCTION

Organic sludges are important by-products of conventional domestic wastewater treatment. The settleable solids that are originally present in raw sewage and those synthesized and bio-flocculated during biological treatment are removed in settling tanks as sludge. The sludges are loose structures of particulate or flocculent solids with included water. The water content of sludges is relatively larger as solids constitute only a small portion of the total sludge volume.

Disposal of sludge presents problems due to two important characteristics of sludge, viz. (i) solids present in sludges are chiefly organic and hence putrescible and (ii) volume of sludge is many times that of its constituents solids. Consequently, various unit operations and processes employed for treatment of sludges aid at stabilization of organic matter and reduction of volume of sludge by removing water. While reduction and stabilization of organic matter are achieved by digestion, incineration and composting, the treatment methods aimed at removed of water from sludges include thickening, dewatering and drying.

Sludge thickening or dewatering is adopted for reducing the volume of sludge or increasing the solids concentration to (a) permit increased loadings to sludge digesters; (b) increase feed solids concentration to vacuum filters; (c) economize on transport costs as in ocean barging in case of raw sludges; (d) minimize the land requirements as well as handling costs when digested sludge has to be transported to disposal sites; and (e) save on the auxiliary fuel that may otherwise be needed when incineration of sludge is practiced.

17.2 SLUDGE THICKENING

This practice is adopted for the separation of greater amount of water from sludge solids than can be attained in settling tanks. Thickening produces a saving in unit costs compared to sludge digestion and dewatering processes.

Three types of thickening are commonly practiced, viz (a) gravity thickening, (b) air flotation, and (c) centrifugation.

17.2.1 Gravity Thickening

Gravity thickening is the most common practice for concentration of sludges. This is adopted for primary sludge or combined primary and activated sludge but is not successful in dealing with activate sludge independently. Gravity thickening of combined sludge is not effective when activated sludge exceeds 40% of the total sludge weight, and other methods of thickening of activated sludge have to be considered.

Gravity thickeners are either continuous flow or fill and draw type, with or without addition of chemicals. Use of slowly revolving stirrers improves the efficiency. Continuous flow tanks are deep circular tanks with central feed and overflow at the periphery. They are designed for a hydraulic loading of 20,000 to 25,000 lpd/m². Loading rates lesser than 12,000 lpd/m² are likely to give too much solids to permit this loading and hence it is necessary to dilute the sludge with the plant effluent.

The surface loadings for various types of sludges are given in Table 17.1 along with solids concentration various types of thickened sludges.

Table 17.1
SURFACE LOADINGS AND SOLIDS CONCENTRATION

Type of Sludge	Solids surface Loading (Kg/day/m ²)	Thickened Sludge Solids concentration (%)
Separate Sludges		
Primary	90 - 140	5 - 10
Activated	25 - 30	2.5 - 3.0
Trickling filter	40 - 45	7 - 9
Combined Sludges		
Primary + activated	30 - 50	5 - 8
Primary + trickling filter	50 - 60	7 - 9

Better efficiencies can be obtained by providing slow revolving stirrers, particularly with gassy sludges.

Continuous thickeners are mostly circular with a side water depth of about 3 m. Concentration of the underflow solids is governed by the depth of sludge blanket up to 1 m beyond which there is very little influence of the blanket. Underflow solids concentration is increased with increased sludge detention time, 24 hours being required to achieve maximum compaction. Sludge blanket depths may be varied with fluctuation in solids production to achieve good compaction. During peak conditions, lesser detention times will have to be adopted to keep the sludge blanket depth sufficiently below the overflow weirs to prevent excessive solids carryover.

It is necessary to ensure provisions for (a) regulating the quantity of dilution water needed; (b) adequate sludge pumping capacity to maintain any desired solids concentration, continuous feed and underflow pumping; (c) protection against torque overload and (d) sludge blanket detection.

17.2.2 Air Floatation

Air floatation units employ floatation of sludge by air under pressure or vacuum and are normally used for thickening of waste activated sludge. These units involve additional equipment, higher operating costs, higher power requirements, more skilled maintenance and operation. However, removal of grease and oil, solids, grit and other material as also odor control are distinct advantages.

In the pressure type floatation units, a portion of the subnatant is pressurized from 3 to 5 kg. per cm² and then saturated with air in the pressure tank. The effluent from the pressure tank is mixed with influent sludge immediately before it is released into the floatation tank. Excess dissolved air then rises up in the form of bubbles at atmospheric pressure attaching themselves to particles which form the sludge blanket. Thickened blanket is skimmed off while the unrecycled subnatant is returned to the plant.

The vacuum type employs the addition of air to saturation and applying vacuum to the unit to release the air bubbles which float the solids to the surface.

The efficiency of air floatation units is increased by the addition of chemicals like alum and polyelectrolytes. The addition of polyelectrolytes does not increase the solids concentration but improves the solids capture from 90 to 98%.

17.2.3 Centrifugation

Thickening by centrifugation is resorted to only when the space limitations or sludge characteristics will not permit the adoption of the other two methods. This method involves high maintenance and power costs. Centrifuges employed are of either disc or solid bowl type. Disc centrifuges are prone to clogging while the latter type gives poorer quality of effluent.

17.3 SLUDGE DEWATERING

Most of the digested primary or mixed sludge can be compacted to a water content of about 90% in the digester itself by gravity but mechanical dewatering with or without coagulant aids or prolonged drying on open sludge drying beds may be required to reduce the water content further. The dewatering of digested sludge is usually accomplished on sludge drying beds which can reduce the moisture content to below 70%. But excess oil or grease in the sludge will interfere with the process. Where the required space for sludge drying beds is not available, sludge conditioning, followed by mechanical dewatering on vacuum filters, filter presses or centrifugation followed by heat drying or incineration could be adopted.

In most parts of the country, the climate is favorable for open sludge drying beds which is economical and easy to manage.

17.3.1 Sludge Drying Beds

This method can be used in all places where adequate land is available and dried sludge can be used for soil conditioning. Where digested sludge is deposited on well drained bed of sand and gravel, the dissolved gases tend to buoy up and float the solids leaving a clear liquid at the bottom which drains through the sand rapidly. The major portion of the liquid drains off in a few hours after which drying commences by evaporation. The sludge cake shrinks producing cracks which accelerates evaporation from the sludge surface. The areas having greater sunshine, lower rain fall and lesser relative humidity, the drying time may be about two weeks while in other areas, it could be four weeks or more. Covered beds are not generally necessary.

17.3.1.1 DESIGN CRITERIA

The sludge drying process is affected by weather, sludge characteristics, system design (including depth of bed) and length of time between scraping and lifting of sludge material. High temperature and high wind velocity improve drying while high relative humidity and precipitation retard drying.

a) *Area of Beds*

The area needed for dewatering and drying the sludge is dependent on the volume of the sludge, cycle time required to retain sludge for dewatering, drying and removal of sludge and making the sand bed ready for next cycle of application and depth of application of sludge on drying bed. The cycle time between two dryings of sludge on drying beds primarily depends on the characteristics of sludge including factors affecting its ability to allow drainage and evaporation of water, the climatic parameters that influence evaporation of water from sludges and the moisture content allowed in dried sludge. The cycle time may

vary widely, lesser time required for aerobically stabilized sludges than for anaerobically digested sludge and for hot and dry weather conditions than for cold and/or wet weather conditions.

Area of land required for sludges can be quite substantial with value of 0.1 to 0.25 m²/capita being reported for anaerobically digested sludge under conditions that are unfavorable for dewatering and drying. The average cycle time for drying may range from a few days to 2 weeks in warmer climates to 3 to 6 weeks or even more in unfavorable ones. A typical worked out example is presented at Appendix 17.2.

b) **Bed Specifications**

A sludge drying bed usually consists of a bottom layer of gravel of uniform size over which is laid a bed of clean sand. Open jointed tile underdrains are laid in the gravel layer to provide positive drainage as the liquid passes through the sand and gravel.

i) Gravel

Graded gravel is placed around the underdrains in layers up to 30 cm with a minimum of 15 cm above the top of the under drains. At least 3 cm of the top layer shall consist of gravel of 3 to 6 mm size

ii) Sand

Clean sand of effective size of 0.5 to 0.75 mm and uniform coefficient not greater than 4.0 is used. The depth of sand may vary from 20 to 30 cm. The finished sand surface shall be level

iii) Underdrains

Underdrains are made of vitrified clay pipes or tiles of at least 10 cm dia laid with open joints. However other suitable materials may also be used. Underdrains shall be placed not more than 6 m apart

iv) Walls

Walls shall preferably be of masonry and extend at least 40 cm above and 15 cm below sand surface. Outer walls should be kerbed to prevent washing outside soil on to beds

v) Dimensions

Drying beds are commonly 6 to 8 m wide and 30 to 45 m long. A length of 30 m away from the inlet should not be exceeded with a single point of wet sludge discharge, when the bed slope is about 0.5%. Multiple discharge points may be used with large sludge beds to reduce the length of wet sludge travel

vi) Sludge inlet

All sludge pipes and sludge inlets are so arranged to easily drain and have a minimum of 200 mm dia terminating at least 30 cm above the sand surface. Splash plates should be provided at discharge points to spread the sludge uniformly over the bed and to prevent erosion of the sand

vii) Drainage

Drainage from beds should be returned to the primary settling units if it cannot be satisfactorily disposed of otherwise

c) *Preparation of Bed*

Sludge drying beds should be prepared well in advance of the time of application of a fresh batch of sludge. All dewatered sludge which has formed a cake should be removed by rakes and shovels or scrapers, care being taken not to pick up sand with the sludge. After the complete removal of sludge cake, the surface of the bed is cleaned, weeds and vegetation removed, the sand levelled and finally the surface properly raked before adding the sludge. The raking reduces the compaction of the sand on the surface and improves the filterability of the bed.

Only properly digested sludge should be applied to the drying beds. Poorly digested sludge will take a much longer time for dewatering. Sludges containing oils, grease and floating matter clog the sand and interfere with percolation. Samples of sludge from the digester should be examined for the physical and chemical characteristics to ensure that it is ready for withdrawal.

d) *Withdrawal of Sludge*

Sludge should be withdrawn from the digester at a sufficiently high rate to clear the pipeline. Rodding and back-flushing of the inlet pipe may sometimes become necessary to make the material flow easily. Valves must be opened fully to start with and later adjusted to maintain regular flow. The flow may be regulated to keep the pipe inlet from being submerged. Naked flames should be prohibited while opening sludge valves and exposed discharge channels.

e) *Removal of Sludge Cake*

Dried sludge cake can be removed by shovel or forks when the moisture content is less than 70%. When the moisture content reaches 40% the cake becomes lighter and suitable for grinding. Some sand always clings to the bottom of the sludge cake and results in loss of sand thus reducing the depth of the bed. When the depth of the bed is reduced to 10 cm, clean coarse sand which matches the original sand, should be used for replenishment to the original depth of the bed.

f) *Hauling and Storage of Sludge Cakes*

Wheel barrows or pick up trucks are used for hauling of sludge cakes. In large plants mechanical loaders and conveyors may be required to handle large quantities of dried sludge. Sludge removed from the bed may be disposed of directly or stored to make it friable, thereby improving its suitability for application to soil.

17.3.2 Mechanical Methods

Vacuum filtration is the most common mechanical method of dewatering, filter presses and centrifugation being the other methods. Chemical conditioning is normally required prior to mechanical methods of dewatering. Mechanical methods may be used to dewater raw or digested sludges preparatory to heat treatment or before burial or landfill. Raw sludge is more amenable to dewatering by vacuum filtration because the coarse solids are rendered fine during digestion. Hence filtration of raw primary mixture of primary and secondary sludges permits slightly better yields, lower chemical requirement and lower cake moisture contents than filtration of digested sludges. When the ratio of secondary to primary sludges increases, it becomes more and more difficult to dewater in the filter. The feed solids concentration

has a great influence, the optimum being 8 to 10%. Beyond 10% sludge becomes too difficult to pump and lower solids concentration would demand unduly large filter surface. In this method, conditioned sludge is spread out in a thin layer in the filtering medium, the water portion being separated due to the vacuum and the moisture content is reduced quickly.

17.3.2.1 SLUDGE CONDITIONING

Prior conditioning of sludge before application of dewatering methods renders it more amenable to dewatering. Chemical conditioning and heat treatment are the two processes normally employed.

i) Chemical conditioning

Chemical conditioning is the process of adding certain chemicals to enable coalescence of sludge particles facilitating easy extraction of moisture. The chemicals used are ferric and aluminium salts and lime, the more common being ferric chloride with or without lime. Digested sludge, because of its high alkalinity exerts a huge chemical demand and therefore the alkalinity has to be reduced to effect a saving on the chemicals. This can be accomplished by elutriation. Polyelectrolytes show promise for sludges with finely dispersed solids. The choice of chemical depends on pH, ash content of sludge, temperature and other factors. Optimum pH values and chemical dosage for different sludges has to be based on standard laboratory tests. The dosage of ferric chloride and alum for elutriated digested sludge are of the order of 1.0 kg/m³ of sludge. Alum when vigorously mixed with the sludge, reacts with the carbonate salts and release CO₂ which causes the sludge to separate and water drains out more easily. Hence for effective results, alum must be mixed quickly and thoroughly. The alum floc, however, is very fragile and its usefulness has to be evaluated vis-a-vis ferric chloride before resorting to its application.

Feeding devices are necessary for applying chemicals. Mixing of chemicals with sludge should be gentle but thorough, taking not more than 20 to 30 seconds. Mixing tanks are generally of the vertical type for the small plants and of the horizontal type for large plants. They are provided with mechanical agitators rotated at 20 to 60 rpm.

ii) Elutriation

The purpose of elutriation of sludge is to reduce the coagulant demand exerted by the alkalinity of the digested sludge, by dilution with water of lower alkalinity followed by sedimentation and decantation. Some end products of digestion such as ammonium bicarbonate which exert increased demand of chemicals in conditioning are removed in the process. There are three methods of elutriation, viz. single stage, multi-stage and countercurrent washing, the water requirement being dependent upon the method used. For a given alkalinity reduction, single stage elutriation requires 2.5 times as much water as the two stage and 5 times as much water as countercurrent washing. Hence single stage washing is used only in small plants. Countercurrent washing, although higher in initial cost, is adopted in all large plants. Water requirement also depends on alkalinity of dilution water, alkalinity of sludge and desired alkalinity of elutriated sludge. Sludge and water are mixed in a chamber with mechanical mixing arrangement, the detention period being about 20 secs. The sludge is then settled in settling tanks and excess water decanted. A maximum surface loading on settling tank of about 40 m³/m²/day and a detention period of about 4 hours are adopted.

Countercurrent elutriation is generally carried out in twin tanks similar to sedimentation tanks, in which sludge and wash water enter at opposite ends. Piping and channels are so arranged that wash water entering the second stage tank comes first in contact with sludge already washed in the first stage tank. The volume of wash water required is roughly 2 to 3 times the volume of sludge elutriated.

The dosage of chemicals, detention period and flow of conditioned sludge to mechanical dewatering units are automatically controlled by float switches so that these variables are adjusted on the basis of performance and the quality of sludge cake coming out.

iii) Heat Treatment (Proteus Process)

In this process, sludge is heated for short periods of time under pressure.

Sludge is preheated in a heat exchanger before it enters a reactor vessel where steam is injected to bring the temperature to 145° to 200°C under pressure of 10 to 15 kg/cm². After a 30 minute contact time, the sludge is discharged through the heat exchanger to a sludge separation tank. The sludge can be filtered through a vacuum filter to a solid content of 40 to 50% with filter yields of 100 kg/m²/hr.

17.3.2.2 EQUIPMENTS

a) *Vacuum Filters*

The vacuum filter consists of a cylindrical drum over which is laid a filtering medium of wool, cloth or felt, synthetic fibre or plastic or stainless steel mesh or coil springs. The drum is suspended horizontally so that one quarter of its diameter is submerged in a tank containing sludge. Valves and piping are arranged to apply a vacuum on the inner side of the filter medium as the drum rotates slowly in the sludge. The vacuum holds the sludge against the drum as it continues to be applied as the drum rotates out of the sludge tank. This pulls water away from the sludge leaving a moist cake mat on the outer surface. The sludge cake on the filter medium is scraped from the drum just before it enters the sludge tank again. Vacuum pumps, moisture traps, filtrate pumps, filtrate receivers, conveyors and pipes and valves are necessary adjuncts to the filter. Operating costs of vacuum filters are usually higher than for sludge drying beds. However, they require less area since dewatering is rapid. The operation is independent of weather conditions and it can be used for dewatering even raw or partially digested sludges requiring drying or incineration. The capacity of the filter varies with the type of sludge being filtered. In calculating the size of filter the desired moisture content of the filter cake is a factor. If wetter cake is acceptable, higher filtration rates and lower coagulant dosage can be used. The filtration rate is expressed in kg of dry solids per square metre of medium per hour. It varies from 10 kg/m²/hr for activated sludge alone to 50 kg/m²/hr for primary sludges. A design rate of 15 kg/m²/hr is a conservative figure that can be used when the quality of the sludge and the type of the filter to be used are not known. Filter drums are rotated at a speed of 7 to 40 rph with a vacuum range of 500 to 650 mm of mercury. The filter run does not exceed 30 hrs per week in small plants to allow time for conditioning, clean up and delays. At larger plants, it may work for 20 hrs a day. The moisture of the filtered cake varies normally from 80% in case of raw activated sludge to 70% for digested primary sludges. Filters should be operated to produce a cake of 60 to 70% moisture if it is to be heat dried or incinerated. At the end of each filter run, the filter fabric is cleaned to remove sticking sludge. A high pressure stream of water is used to clean the filter cloth. The filters are usually located in a separate room or building with adequate light and ventilation.

b) *Centrifugation*

The process of high speed centrifuging has been found useful to reduce the moisture in sludge to around 60%. Usually the liquor from the centrifuge has a high solids content than filtrate from sand drying beds. Return of this liquor to the treatment plant may result in a larger recirculated load of these fine solids to the primary settling and sludge system and also in reduced effluent quality.

17.3.3 Heat Drying

The purpose of heat drying is to reduce further the moisture content and volume of dewatered sludge, so that it can be used after drying without causing offensive odors or risk to public health. Several methods such as sludge drying under controlled heat, flash drying, rotary kiln, multiple hearth furnaces, etc., have been used in combination with incineration devices. Drying is brought about by directing a stream of heated air or other gases at about 350°C. The hot gases, dust and ash released during combustion are to be removed by suitable control mechanisms to minimize air pollution. The dried sludge removed from the kilns is granular and clinker-like which may be pulverized before use as soil conditioner.

17.3.4 Incineration

The purpose of incineration is to destroy the organic material, the residual ash being generally used as landfill. During the process all the gases released from the sludge are burnt off and all the organisms are destroyed. Dewatered or digested sludge is subjected to temperatures between 650°C to 750°C. Cyclone or multiple hearth and flash type furnaces are used with proper heating arrangements with temperature control and drying mechanisms. Dust, fly ash and soot are collected for use as landfill.

It has the advantages of economy, freedom from odors and a great reduction in volume and weight of materials to be disposed of finally. But the process requires high capital and recurring costs, installation of machinery and skilled operation. Controlled drying and partial incineration have also been employed for dewatering of sludges before being put on conventional drying beds.

17.4 SLUDGE DIGESTION

The principal purposes of sludge digestion are to reduce its putrecibility or offensive odour, pathogenic contents and to improve its dewatering characteristics. This can be achieved through any of the following biological processes:

- i) Anaerobic digestion
- ii) Aerobic digestion

17.4.1 Anaerobic Digestion

Anaerobic digestion is the biological degradation of organic matter in the absence of free oxygen. During this process, much of the organic matter is converted to methane, carbon-di-oxide and water and therefore the anaerobic digestion is a net energy producer. Since little carbon and energy remain available, to sustain further biological activity, the remaining solids in the sludge are rendered stable.

17.4.1.1 MICROBIOLOGY OF THE PROCESS

Anaerobic digestion involves several successive biochemical reactions carried out by a mixed culture of microorganisms. There are three degradation stages viz. hydrolysis, acid formation & methane formation. Fig.17.1 shows, in simplified form, the reactions involved in anaerobic digestion.

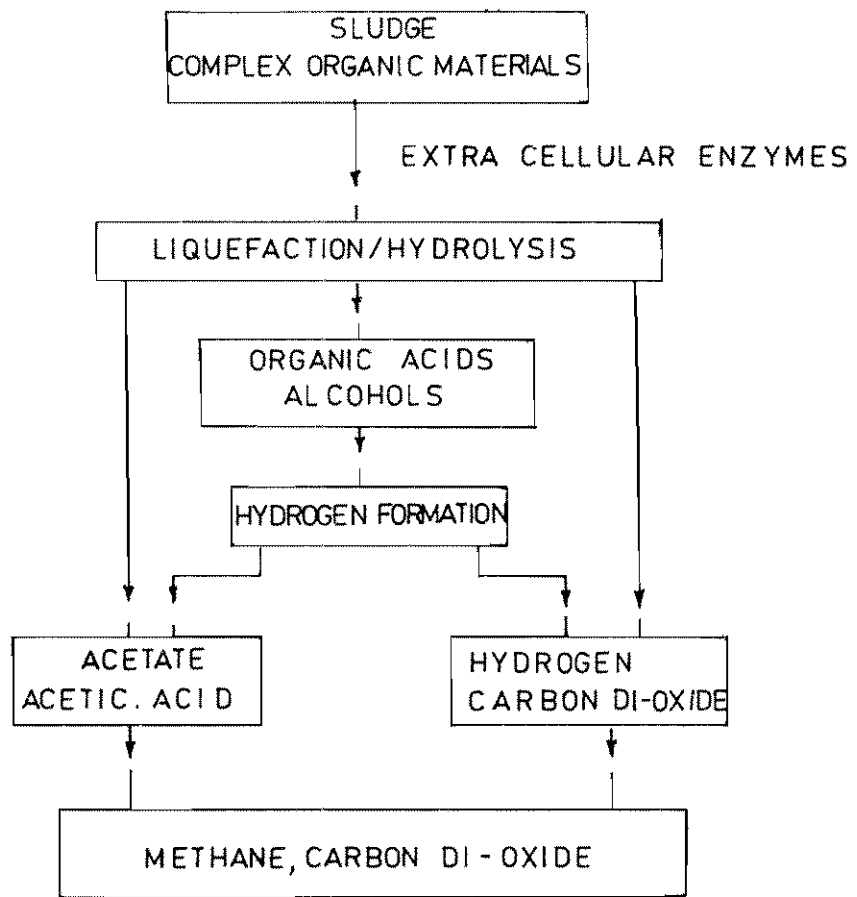

FIG.17.1:ANAEROBIC DIGESTION MECHANISMS

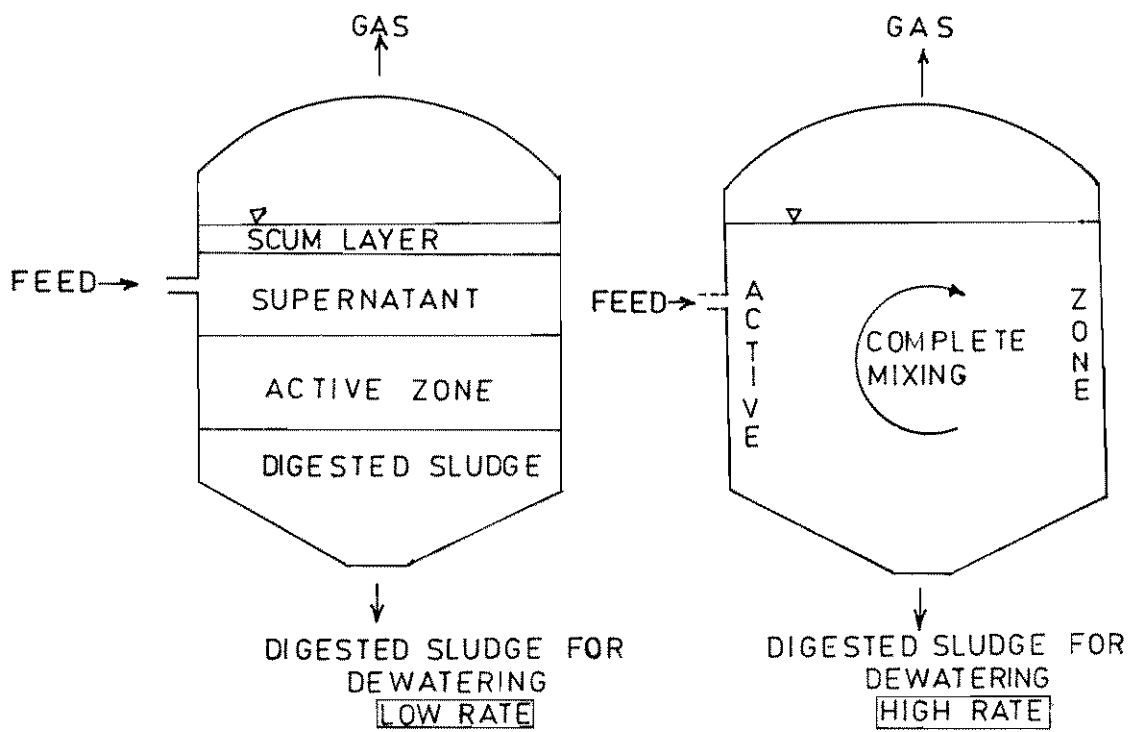

FIG.17.2:SLUDGE DIGESTION SYSTEM

In the first stage of digestion, the complex organic matter like proteins, cellulose, lipids are converted by extra cellular enzymes into simple soluble organic matter.

In the second stage, the soluble organic matter is converted by acetogenic bacteria into acetic acid, hydrogen, carbon dioxide and other low molecular weight organic acids.

In the third stage, two groups of methanogenic bacteria, strictly anaerobic, are active. While one group converts acetate into methane and bicarbonate, the other group converts hydrogen and carbon-dioxide into methane.

For satisfactory performance of an anaerobic digester, the second and third stages of degradation should be in dynamic equilibrium i.e. the volatile organic acids should be converted into methane at the same rate as they are produced. However, methanogenic microorganisms are inherently slow-growing compared to the volatile acid formers and they are adversely affected by fluctuations in pH, concentration of substrates and temperature. Hence, the anaerobic process is essentially controlled by the methanogenic microorganisms.

17.4.1.2 TYPES

Two different types in anaerobic sludge digestion process viz. Low rate and High rate, are used in practice. The basic features of these processes are shown in Fig.17.2.

a) *Low Rate Digestion*

Low rate digestion is the simplest and oldest process. Essentially a low rate digester is a large storage tank, occasionally, with some heating facility. The basic features of this process are shown in Fig.17.2.

Raw sludge is fed into the digester intermittently. Bubbles of sewage gas are generated and their rise to the surface provides some mixing. In the case of few old digesters, screw pumps have been installed to provide additional intermittent mixing of the contents, say once in 8 hrs for about an hour. As a result, the digester contents are allowed to stratify, thereby forming four distinct layers: a floating layer of scum, layer of supernatant, layer of actively digesting sludge and a bottom layer of digested sludge. Essentially the decomposition is restricted to the middle and bottom layers. Stabilized sludge which accumulates and thickens at the bottom of the tank is periodically drawn off from the centre of the floor. Supernatant is removed from the side of the digester and recycled back to the treatment plant.

b) *High Rate Digestion*

The essential elements of high rate digestion are complete mixing and more or less uniform feeding of raw sludge. Pre-thickening of raw sludge and heating of the digester contents are optional features of a high rate digestion system. All these four features provide the best environmental conditions for the biological process and the net result is reduced digester volume requirement and increased process stability.

- 1) Complete mixing of sludge in high rate digesters creates a homogeneous environment throughout the digester. It also quickly brings the raw sludge into contact with microorganisms and evenly distributes toxic substances if any, present in the raw sludge. Furthermore, when stratification is prevented because of mixing, the entire digester is available for active decomposition, thereby, increasing the effective solids retention time.

- 2) Pre-thickening of raw sludge before digestion results in the following benefits :
- i) Large reduction in digester volume requirements
 - ii) The thickener supernatant is of far better quality than digester supernatant, thereby it has less adverse impact when returned to the wastewater treatment stream
 - iii) Less heating energy requirements
 - iv) Less mixing energy requirements

There is however a point, beyond which, further thickening of raw sludge, has following effects on digestion:

The higher solid concentration, beyond 6%, in the digester affects the viscosity, which, in turn affects mixing and hence deserves special consideration.

In case of highly thickened raw sludge, the concentration of salts and heavy metals present in the raw sludge and end products of digestion such as volatile acids, ammonium salts may exceed the toxic levels.

- c) Sludge temperature is one of the important environmental factors. Where the digester sludge temperatures are low, digester heating is beneficial because the rate of microbial growth and therefore, the rate of digestion increases with temperature.

17.4.1.3 DIGESTER CAPACITY

Determination of digester tank volume is a critical step in the design of anaerobic system. The digester volume must be sufficient to prevent the process from failing under all accepted conditions. Process failure is defined as accumulation of volatile acids i.e. resulting in decrease in pH, when volatile acids/alkalinity ratio becomes greater than 0.5 and the cessation of methane production occurs. Once the digester turns sour, it usually takes several days to return to normal operation, after the corrective actions are taken. Digester capacity must also be large enough to ensure that raw sludge is adequately stabilized as discussed below in the paragraph on Solids Retention Time. The relationship between % volatile matter in the raw sludge, reduction in % of volatile matter and detention time is shown in Fig. 17.3.

a) *Loading Criteria*

Traditionally, volume requirements for anaerobic digestion have been determined from empirical loading criteria. Volatile solids loading rate-kg VSS/day/m³ criteria has been commonly used to size the anaerobic digesters. Table 17.2 lists the typical loading rates used for design purpose. However, it is now recognized that process performance is better correlated to Solids Retention Time (SRT), which are also shown in the table and are discussed subsequently.

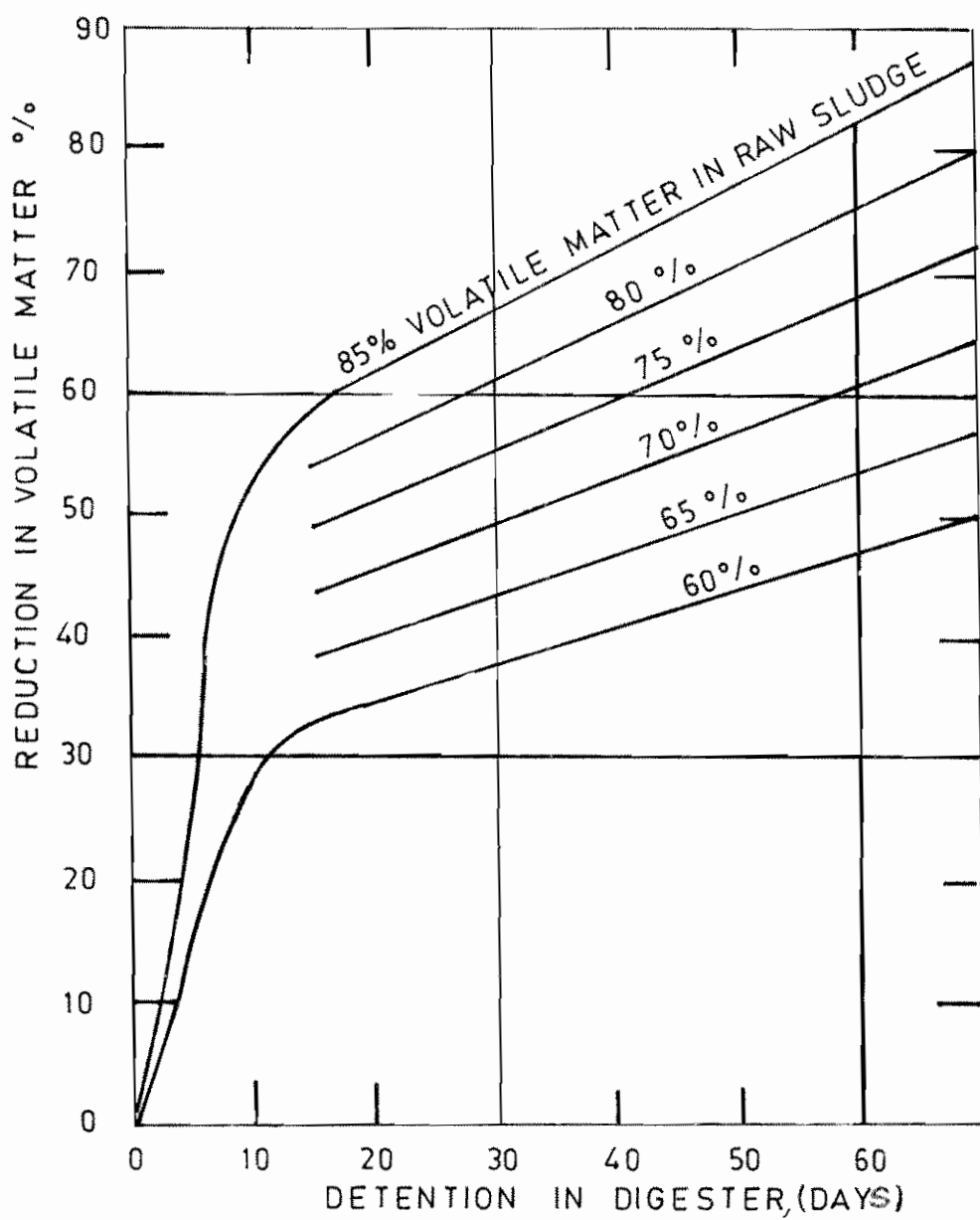

FIG.17.3:REDUCTION OF VOLATILE MATTER AS RELATED TO DIGESTER DETENTION TIME

TABLE 17.2
TYPICAL DESIGN CRITERIA FOR SIZING MESOPHILIC
ANAEROBIC SLUDGE DIGESTERS

Parameters	Low Rate Digestion	High Rate Digestion
Volatile Solids Loading rate KgVSS/day/m ³	0.6 - 1.6	1.6 - 6.4
Solids Retention Time, days	*	10 - 20
Hydraulic Retention Time, days	30 - 40	10 - 20

* Computation of actual SRT is rather difficult as it depends on the capacity utilization.

b) Solids Retention Time

The most important consideration in sizing anaerobic digester is that the microorganisms must be given sufficient time to reproduce so that they can (a) replace the cells lost with the withdrawn sludge and (b) adjust the microbial mass to the organic loading and its fluctuation.

The key design parameter for anaerobic biological treatment is the biological solids retention time (SRT), which is the average time a unit of microbial mass is retained in the system. In the anaerobic digesters without recycle, the SRT is equivalent to the hydraulic retention time i.e., volume of digester/volume of sludge withdrawn per day. Experiments have proved that percentage of destruction of volatile solids and formation of methane decreases as the SRT is reduced. The SRT can be lowered to a critical point (SRT_c) beyond which the process will fail completely.

Temperature has an important effect on bacterial growth rates and accordingly changes the relationship between SRT and digester performance. The effect of temperature on volatile solids destruction is shown in Fig.17.4. The inset in Fig.17.4 - shows that at SRT values greater than 30 days, fluctuations in temperature do not affect the digester stability, i.e., no significant change in percentage volatile solids reduction.

Depending upon the temperature range, different kinds of micro-organisms are active in the digester. For an operating temperature range of 20 - 40°C, the range is known as mesophilic and 40 - 60°C, the range is known as thermophilic. The ambient temperature in the country is generally favorable for operation under mesophilic condition, throughout the year. But in special conditions, where extremely low temperatures are likely to be encountered, it may be necessary to heat the digesters in specific periods of the year.

Size of anaerobic digester should be adequate enough to ensure that the solids retention time in the system is always well above the SRT_c. Typical solids retention time design criteria followed for high rate digestion design are given in Table 17.3.

TABLE 17.3
SOLIDS RETENTION TIME AT DIFFERENT TEMPERATURES

Operating Temperature °C	Solids Retention Time, days	
	SRT _d	Suggested for Design (SRT _d)
18	11	28
24	8	20
30	6	14
35	4	10
40	4	10

The solids retention time design criteria must be met under all anticipated conditions including :

- i) Maximum grit and scum accumulations: Considerable amount of grit and scum may accumulate before a digester is cleaned. This reduces the active volume of the tank. Hence about 0.6m to 1.0m additional depth for grit and scum accumulation must be provided
- ii) Free Board: About 0.6 to 0.8m free board (from rim of the digester wall to the highest liquid level) must be allowed for differences in the rate of feeding and withdrawing and to provide reasonable operational flexibility.
- c) **Storage For Digested Sludge**

Storage capacity for digested sludge is required in places where digested sludge is applied to drying beds for dewatering, and use of sludge drying beds is interrupted during monsoon periods. This additional capacity requirement can be met either by increasing the digester capacity or by providing a separate digested sludge holding tank. Normally, an additional 10-15 days digested sludge storage capacity should be sufficient. However if local meteorological data is available, such data should be used to determine the capacity needed for storage.

17.4.1.4 SIZING OF LOW RATE DIGESTERS

Lack of proper mixing in the conventional digesters leads to stratification, giving rise to distinct layers of scum, supernatant, actively digesting sludge and digested sludge. The supernatant is withdrawn periodically and returned to the influent of the treatment plant while the sludge is added at mid depth and withdrawn from the bottom.

Since the supernatant is removed during digestion, resulting in decrease in digesting sludge volume, the capacity of the digester is given by the expression :-

$$V = [V_f - 2/3 (V_f - V_d)] T_d \quad (17.1)$$

where

- V = Volume of digester, m³
- V_f = Volume of fresh sludge m³ added per day.
- V_d = Volume of digested sludge m³ withdrawn per day.
- T_d = HRT, days.

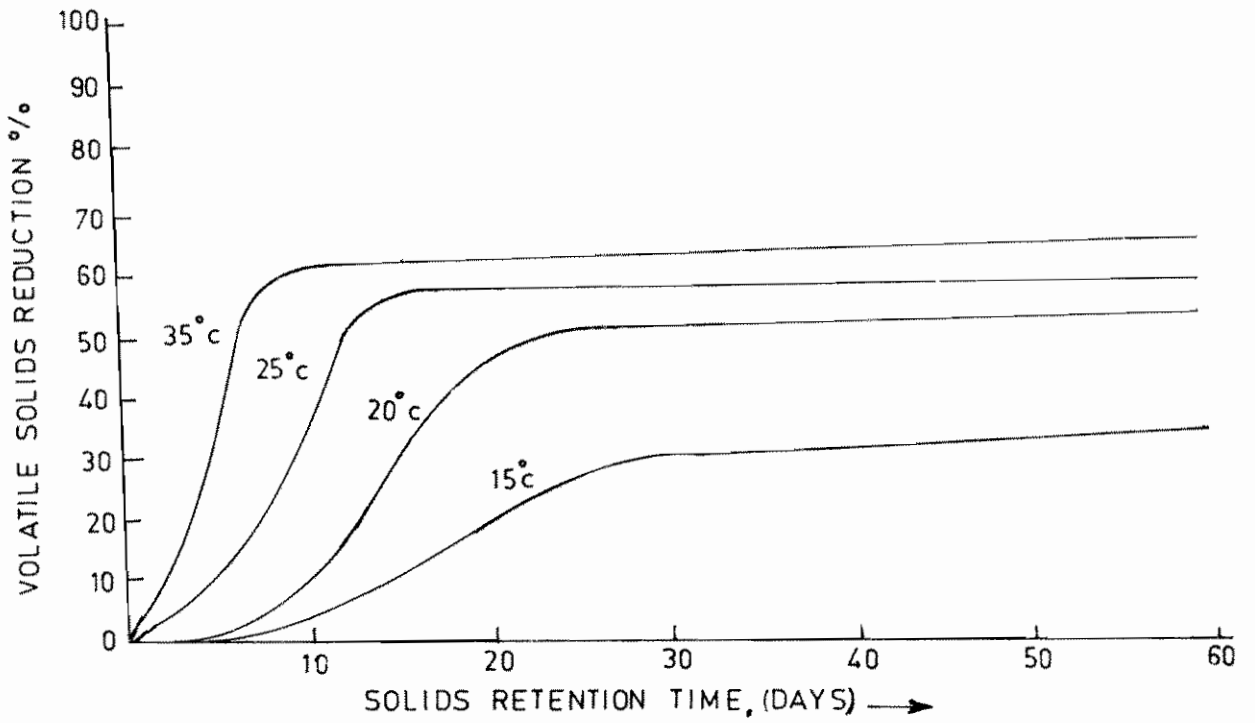
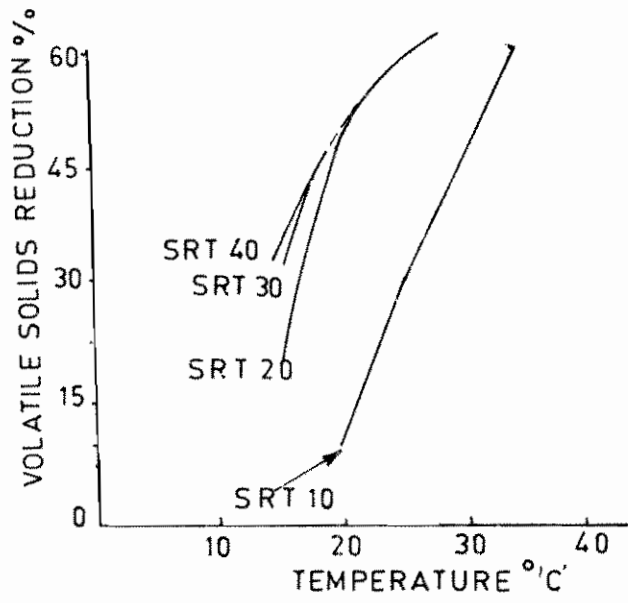

FIG.17.4: EFFECT OF SOLIDS RETENTION-TIME AND TEMPERATURE ON VOLATILE SOLIDS REDUCTION IN A LABORATORY SCALE COMPLETELY MIXED ANAEROBIC DIGESTER

Additional capacity to store sludge during the monsoon period - when the sludge drying bed option is used for sludge dewatering, is given by the expression:

$$\text{Additional monsoon storage volume} = V_d T_2 \quad (17.2)$$

Where T_2 = Storage in days, during monsoon.

The digester can be a single unit or two units - the primary and the secondary, the former being provided with the needed time for digestion and the latter to meet the requirements of monsoon storage.

As discussed above in paragraph 17.3.1.3, further additional capacity to compensate for grit accumulation and free board, should be provided.

17.4.1.5 SIZING OF HIGH RATE DIGESTERS

Because of good mixing, there is no stratification and hence no loss of capacity due to scum or supernatant layers. By adopting more or less continuous addition of raw sludge and resorting to pre-thickening of the raw sludge to a solid content of about 6%, the digester volume can be designed for 10-15 days retention time. When the digested sludge is to be dewatered on sludge drying bed, a second stage digester is normally provided where separation of supernatant and reduction in volume of sludge due to gravity thickening take place and digestion is completed. Additional storage capacity needed for the monsoon period can also be provided in the second stage digester. Capacities for high rate digestion may be determined by

$$V' = V_f T_n \quad (17.3)$$

$$V'' = [V_f - 2/3(V_f - V_d)] T + V_d T_2 \quad (17.4)$$

Where

- V' = Volume of first stage digester, m^3
- V'' = Volume of second stage digester, m^3
- V_f = Volume of fresh sludge m^3 added per day
- V_d = Volume of digested sludge m^3 withdrawn per day
- T_n = Detention time in the high rate digester, days
- T = Detention time in the second stage digester, which is of the order of 10 days and
- T_2 = Storage in days, during monsoon

As discussed above in paragraph 17.4.1.3, further additional capacity to compensate for grit accumulation and free board, should be provided.

A typical mass balance of solids in sludge is given in Table 17.4.

17.4.1.6 DIGESTER ELEMENTS

a) *Number of Units*

Conventional digesters are designed as single units for plants treating up to 4 mld. For larger

plants, units are provided in multiples of two, the individual capacity not exceeding 3 mld.

High rate digesters are designed comprising primary and secondary digestion tanks, each unit generally capable of handling sludge from treatment plants up to 20 mld.

b) *Digester Shape and Size*

The most common digester shape is a low, vertical cylinder with dia. ranging from 6-38 m and with height ranging from 6-12 m. Digester mixing is effective, when the ratio of digester diameter to sludge depth is between 1.5 and 4.

c) *Free Board and Depth*

The free board is dependent upon the type of cover and the maximum gas pressure. For fixed dome or conical roofs free-board between the liquid level and the rim of the digester wall should not be less than 0.6m. For flat covers, the free board between water level and the top of the tank wall should preferably be not below 0.6m. For fixed slab roofs, a free board of 0.8m is recommended.

Sludge depth in a digester has to be carefully worked out. Too deep a digester causes excessive foaming which may result in choking of the gas pipes, building up high pressures in the digester. In case of conventional low rate digester, when gas production reaches a figure of about $9 \text{ m}^3/\text{day}/\text{m}^2$ of top surface of sludge, foaming becomes noticeable. Therefore, before the tank depth and surface area of a digester are worked out, maximum gas production rate should be determined. An average of about 0.9 m^3 of gas is produced per kg of volatile solids destroyed. The optimum diameter or depth of digester is calculated such that at the average rate of daily gas production, the value of 9 m^3 per m^2 of tank area is not exceeded.

d) *Floor Slope*

The floor slope should be in the range of 1 in 6 to 1 in 10 to facilitate easy withdrawal of sludge. The digester floor should be designed for uplift pressure due to the subsoil water or suitably protected by anchoring.

TABLE 17.4
MASS BALANCE OF SOLIDS IN SLUDGES - PRIMARY AND
EXCESS ACTIVATED SLUDGE, BEFORE AND AFTER HIGH RATE DIGESTION
(PER CAPITA PER DAY BASIS)

	Treatment Process	Total (gm)	Volatile (gm)	Non volatile (gm)	% of solids in wet sludge
i.	RAW SEWAGE CHARACTERISTICS				
a.	Total S.S. in sewage	90	63	27	-
b.	Settleable solids (60%)	54	38	16	-
c.	Non settleable solids (40%)	36	25	11	-
ii.	PRIMARY SEDIMENTATION AND DIGESTION				
a.	Solids removed as primary sludge	54	38	16	4 - 5
b.	Solids digested (a)	-19	-19	-	-
c.	Solids remaining in the digested primary sludge	35	19	16	2.6 - 3.3
iii.	PRIMARY SEDIMENTATION + ACTIVATED SLUDGE PROCESS & DIGESTION				
a.	Solids removed as primary sludge	54	38	16	4 - 5
b.	Non settleable solids entering the activated sludge process	36	25	11	-
c.	Solids digested in the activated sludge process 100% of volatile solids (b)	-25	-25	-	-
d.	Non volatile solids (of raw-sewage) that will be entering the final sedimentation tank.	11	-	11	-
e.	Excess activated solids produced per capita/day (c)	14.3	10	4.3	0.5 - 0.8
f.	Solids carried away by the treated effluent (d)	-1.5	-1	-0.5	-
g.	Combined primary and excess activated sludge feed to the digester (a+d+e-f) (without pre-thickening)	77.8	47	30.8	3 - 4
h.	Solids digested (a)	-23.5	-23.5	-	-
i.	Solids remaining in the digested sludge	54.3	23.5	30.8	2.1 - 2.5

FOOTNOTES

- a) It is assumed that 50% of the volatile matter is destroyed during digestion.
 - b) The net solids destruction/digestion per unit of solids entering the activated sludge process and the remaining non destructed organic solids are taken into account in the step (e) - computation of excess activated solids produced per capita/day.
 - c) It is assumed that the BOD removed per capita per day in a conventional activated sludge process is $200 \text{ g/m}^3 \cdot 0.150 \text{ m}^3/\text{day} \cdot 0.95(\text{efficiency}) = 28.5 \text{ gms}$. For an assumed excess sludge production rate of 0.5 kg per kg of BOD removed, the excess sludge produced per capita per day is 14.3 kg.
 - d) For an effluent suspended solids conc. of 10 mg/l, S.S. carried away by the treated effluent = $10 \text{ gm/m}^3 \cdot 0.150 \text{ m}^3/\text{day} = 1.5 \text{ gm/day}$.
- In this example, the additional recycle solid loads from sludge treatment processes such as digestion, dewatering etc. have not been taken into account. The solids load from such processes could have a significant effect on the quantities of waste activated sludge and primary sludge produced.
- The above figures should only be used as indicative figures and the actual sludge dry solids balance should be computed, on similar lines on the basis of actual design/field data.

e) **Roofing**

Sludge digesters can have either fixed or floating roofs. Reinforced concrete domes, conical or flat slabs are used for fixed roof and steel domes are used for floating cover. Steel floating covers may either rest on the liquid or act as gas holders in the digesters themselves. If a floating cover is used for gas holder in a digestion tank, an effective vertical travel of 1.2 to 2 m should be provided.

f) **Digester Control Room**

Normally a control room is provided near the digesters to house the piping and the process control equipment, which are principally the sludge heating units, sludge transfer and recirculation pumps, sludge sampling sinks, thermometers, blowers for ventilation and electrical control equipment. Where heating of sludge digesters is practiced, the operation could be managed by locating conveniently, the necessary valves for supernatant and sludge withdrawal, in the digester wall itself. However, in sewage treatment plants having more than four digesters, it is advisable to have a separate operation control room to house the necessary control equipments for convenient operation.

g) **Mixing of digester contents**

A certain amount of natural mixing occurs in anaerobic digester caused by both the rise of sludge gas bubbles and the thermal convection currents created by the addition of heated sludge. This effect of natural mixing is significant, particularly in case of high rate digesters fed continuously. However, this natural mixing is not sufficient to ensure stable performance of the digestion process. Therefore, methods used for mixing include external pumped circulation, internal mechanical mixing and internal gas mixing.

External pumped circulation while relatively simple is limited in application because of large flow rates involved. However, this method can achieve substantial mixing, provided that sufficient energy in the range of 5-8 watts/m³ is dissipated in the digester. More energy will be required if piping losses are significant. Pumped circulation allows external heat exchanges to be used for heating the digester contents and uniform blending of raw sludge with heated circulating sludge prior to the raw sludge's entry to the digester.

Internal mechanical mixing of digester contents, by means of propellers, flat-bladed turbines, or draft tube mixers are also often used. Mechanical mixers can be installed through the cover or walls of the digester. Substantial mixing can be effected with about 5-8 watts/m³ of digester contents.

Internal gas mixing types normally used for digesters are:

- * The injection of a large sludge gas bubble at the bottom of a 30 cm diameter tube to create piston pumping action and periodic surface agitation.
- * The injection of sludge gas sequentially through a series of lances suspended from the digester cover to as great a depth as possible, depending on cover movement.
- * The free or unconfined release of gas from a ring of spargers mounted on the floor of the digester.
- * The confined release of gas within a draft tube positioned inside the tank.

The first method generally has a low power requirement and consequently, produces only a low level of mixing. As a result, the major benefit derived from its use is in scum control. Lance free gas lift, and draft tube gas mixing, however, can be scaled to induce strong mixing of the digester contents. The circulation patterns produced by these two mixing methods differ. In the free gas lift system, the gas bubble velocity at the bottom of the tank is zero, accelerating to a maximum as the bubble reaches the liquid surface. Since the pumping action of the gas is directly related to the velocity of the bubble, there is no pumping from the bottom of the tank with a free gas lift system. In contrast, a draft tube acts as a gas lift pump which, by the law of continuity, causes the flow of sludge entering the bottom of the draft tube to be the same as that exiting at the top. Thus, the pumping rate is largely independent of height. The significance of this difference is that draft tube mixers induce bottom currents to prevent or at least reduce accumulations of settleable material. Another difference among internal gas mixing systems is that the gas injection devices in a free gas lift system are fixed on the bottom of the digester and thus cannot be removed for cleaning without draining the tank. To reduce clogging problems, provisions should be made for flushing the gas lines and diffusers with high pressure water. With the lance and draft tube systems, the gas diffusers are inserted from the roof and, therefore, can be withdrawn for cleaning without removing the contents of the tank. A drawback of these systems, though, is that the draft tube and gas lines suspended inside the tank may foul with rags and debris contained in the digesting sludge. Generally strong mixing can be achieved if 5 to 8 watts/m³ of digester content is dissipated in the digester.

h) *Piping*

Cast Iron is commonly used for pipelines carrying sludge including fittings and joints. Pipes should be well supported and be capable of being drained. Vents should be provided at high points in order that the gas generated by the digesting sludge does not accumulate in these pipelines. Adequate number of flanges and flexible couplings should be provided on exposed sludge lines to facilitate dismantling and insertion of cleaning equipment whenever necessary. In long pipe runs, tees with flanges equipped with 40 to 60 mm hose connectors should be provided for easy cleaning and flushing of the pipe.

Flushing is an important requirement and adequate arrangements should be provided for flushing the sludge lines with water or clarified sewage.

A minimum dia of 200 mm should be used for the sludge pipelines for both gravity withdrawal and suction to pumps. Velocities of 1.5 to 2.4 mps should preferably be maintained to prevent solids deposition and accumulation of grease which ultimately clogs sludge piping.

Primary and digested sludge have different hydraulic characteristics from those of water, though the secondary sludge is almost similar to water in its characteristics. The head loss in sludge pipes increases with the increase in percentage of solids and as such 'C' values of 40 to 50 in Hazen William formula should be used for designing the pipelines.

For gas lines CI, GI or HDPE are commonly used. Galvanized steel may also be used for exposed gas piping. Flanged joints may be provided for exposed gas piping of sizes 100 mm and above in dia while screw or welded type joints are recommended for pipe less than 100 mm. Mechanical joints should be used for underground piping. It is necessary that all gas piping be located at a level that will allow proper draining of the condensate. It is desirable to maintain a gas pipe slope of 1 in 50 with a minimum of slope of 1 in 100 for adequate drainage. Gas pipes should preferably be painted with bituminous coating. For dia of 100 mm and above, cast iron with flanged gasketed joints or flexible mechanical joints may be used. Adequate pipe supports should be provided to prevent breakage. It is desirable to provide a flanged pipe bypass before a gas meter. A firm foundation should also be laid below the pipe and caution must be exercised during back filling to prevent any disturbance of the alignment and grade. In highly acidic or alkaline soils, the pipe must be wrapped with either asbestos or some other protective material. Coal tar enamel may also be used in some cases. Cathodic protection is not generally needed on gas lines. Adequate number of drip traps must be provided in gas pipelines, especially at the downward bends. Suitable number of tees should also be provided with removable screwed plugs or flanges for cleaning purposes. A drip trap of 1 litre capacity would be satisfactory. Trap outlets should run to floor drains wherever convenient. It is preferable to use positive type traps which prevent gas from escaping while emptying the condensate.

i) *Sampling sinks and valves*

A sink should be provided for each digester unit for drawing the supernatant liquor and sludge from various levels in the digester. Sinks should either be of white enamelled cast iron or of stainless steel. They should be made at least 30 cm deep. The supply of adequate water for flushing the sinks should also be provided.

The sludge sampling pipes usually of GI should be short and between 40 to 50 mm in dia. These pipes may be arranged so as to draw samples from at least three levels in the digester at 0.6 m intervals. Sink valves should be either brass plug type or CI flanged type.

j) *Liquid level indicator*

The digester may be designed for a fixed liquid level. Alternatively, a liquid level indicator with gauge board or any other positive level measuring device may be used for each digester.

k) *Gas collection*

Sludge gas is normally composed of about 60 to 70% methane and 25 to 35% carbon dioxide by volume, with smaller quantities of other gases like hydrogen sulphide, hydrogen, nitrogen and oxygen. The combustible constituent in the gas is primarily the methane. Depending upon the sulphate content of the sewage and the sludge, the concentration of hydrogen sulphide in the gas varies. Hydrogen sulphide in

addition to its corrosive properties imposes a limit on the usability or causes nuisance during the burning of the gas. Sludge gas containing 70% methane has a fuel value of about 5,800 k cal/m³. In term of solids digested, the average gas production is about 0.9m³/kg. of volatile solids destroyed at a normal operating pressure of 150 to 200 mm of water.

Minimum or maximum rates of gas production will however depend upon the mode of feeding of raw sludge into the digester. When batch feeding is practiced, the minimum and maximum gas production rates may vary from 45% to more than 200%. In the continuous feeding system, the difference between the maximum and the minimum is considerably reduced. Intermittent mixing of digester contents is also responsible for wide fluctuations in gas production rates. It is, therefore, desirable to feed the high rate digesters with raw sludge and run the mixing device as continuously as possible to obtain not only a uniform rate of digestion but also uniform production of gas.

Sludge gas should be collected under positive pressure to prevent its mixing with air and causing explosion. The explosive range of sludge gas is between 5 to 15% by volume of gas with air. The gas may be collected directly from under a floating cover on the digester or from the fixed cover by maintaining a constant water level. Where primary and secondary units are provided to operate in series with the primary having a fixed cover and the secondary with a gas holding or floating cover, the gas piping from the each digester should be interconnected. A separate gas holder may be provided to collect the gas from the primary unit where the secondary units are kept open.

A gas dome above the digester roof should be used for gas take off. The velocity in sludge gas piping should not exceed 3.5 mps to prevent carry over of the condensate from the condensation traps and avoid high pressure loss and damage to meters or flame traps and other appurtenances of the system.

An integrating meter made of corrosion resistant material should be used to measure gas production from the digesters. Removal of condensate from the meter is also desirable. Pressure release valves are provided for controlling the gas in the digester by releasing gas pressure exceeding 200 to 300 mm of water and also preventing partial vacuum and possible cover collapse during rapid withdrawal of sludge or gas.

A distance of at least 30 m should be kept between a waste gas burner and a digestion tank or gas holder to avoid the possibility of igniting the gas mixture. Waste gas burners should be located in the open for easy observation. A pilot device should also be provided with the waste gas burners. Condensate traps, pressure release valves and flame traps should also be provided ahead of waste gas burners. Manometers indicating the gas pressure in cm of water may be used on the main gas line from the digester or ahead of the gas utilization device. A common open end U tube manometer should not be used for such purposes as it may be hazardous.

Where the gas is to be used as domestic fuel or for power generation, additional equipments like compressor, H₂S Scrubber may have to be used.

1) **Gas holder**

The primary purpose of a gas holder is to adjust the difference in the rate of gas production and consumption as well as to maintain uniform pressure at the burner. When gas holders are also used for storage of gas for utilization, a storage capacity of at least 25% of the total daily gas production should be provided.

The gas holders may be of the following types:

- i) A bell shaped cylindrical tank submerged in water installed either on the top of a digester or as a separate unit. The structure holding the water may be made of RCC. As the gas enters or leaves, the holder rises or falls
- ii) A pontoon cover type which floats on the liquid content of the digester consisting of steel ceiling, skirt plates, a gas dome and steel trusses
- iii) Dry type gas holder consisting of a cylindrical steel tank in which a disc-shaped piston makes contact at its periphery with the inside of the tank. The gas enters the holder from beneath the piston which floats on the gas. Leakage of gas is prevented by either tar or a felt seal around the edge of the piston. A suitable roof should be provided if this type of dry gas holder is installed
- iv) A high pressure holder either cylindrical or spherical in shape and made of either welded or rivetted steel construction, for storing the gas under high pressure. This type of gas holder is seldom used for sewage treatment plants unless the gas has to be utilized for special purposes.

The appurtenances for gas holders include ladders, condensate drains, pressure gauges and safety valves.

17.4.1.7 PERFORMANCE OF DIGESTERS

The following parameters of the digested sludge are indicative of good design:

- | | | | |
|----|--|---|--------------------|
| a) | Approximate % of Volatile Solids reduced in digestion | : | 50 % |
| b) | Gas production per kg of volatile matter destroyed | : | 0.9 m ³ |
| c) | pH of the digesting sludge | : | 7 - 8 |
| d) | Methane content of gas produced | : | 60 - 70% |
| e) | Solid contents in the digested sludge for a feed sludge solids content of 4-6% | | |
| | i) Low rate digesters | | |
| | Primary | : | 10 - 15% |
| | Mixed | : | 6 - 10% |
| | ii) High rate digesters | | |
| | Primary | : | 2.6 - 4% |
| | Mixed | : | 2.0 - 3% |
| f) | Volatile acids concentration | : | 200 - 400 mg/l |

g)	Grease	:	Practically absent
h)	Color	:	Black
i)	Bicarbonate Alkalinity	:	2000-5000 mg/l

17.4.2 Aerobic Digestion

Aerobic digestion is also a useful method of stabilizing sewage sludge. It can be used for secondary tank humus or for a mixture of primary and secondary sludge but not for primary sludge alone. The major advantage of aerobic digestion over the anaerobic digestion are:-

- i. lower BOD concentration in digester supernatant
- ii. production of odourless and easily dewaterable biologically stable digested sludge
- iii. recovery of more basic fertilizer value in the digested sludge
- iv. lower capital cost, and
- v. fewer operational problems.

Because of these advantages, aerobic digesters are being increasingly used particularly for small treatment plants. However, running cost in terms of the power cost, is much higher than for anaerobic digesters.

The factors that should be considered in designing an aerobic digester include detention time, loading criteria, oxygen requirement, mixing and process operation. The volatile solids destroyed in aerobic digestion at about 10 to 12 days time, at a temperature of 20 C would be 35 to 45%. Higher temperature will result in reduction in the period of digestion. Oxygen requirements normally vary between 1.7 to 1.9 gm/gm of volatile solids destroyed. It is also desirable to maintain the dissolved oxygen between 1 and 2 mg/l in the system. Operational difficulties may be expected if compressed aeration is practiced. Extended aeration system including oxidation ditches are examples of aerobic digestion.

17.4.3 Merits and demerits of anaerobic digestion

Anaerobic digestion offers the following major advantages over aerobic digestion process:

- i) Recovery of methane, a useful source of energy, as a by-product. The process is a net energy producer, since the energy content of the digester gas is more than the energy demand for mixing and heating of the digester contents
- ii) Anaerobically digested sludge contains nutrients and organic matter that can improve the fertility and texture of soils
- iii) Pathogens in the sludge die off during the relatively long detention periods used in anaerobic digestion.

Following are the major disadvantages of anaerobic digestion process :

- i) Relatively large closed digestion tanks are required, resulting in high capital investment costs
- ii) Microorganisms involved in anaerobic digestion are sensitive to small changes in the environment. Close process control and performance monitoring are required to prevent upsets
- iii) Supernatant from anaerobic digestion often have a high oxygen demand and high concentration of nitrogen and suspended solids.

17.5 SLUDGE DISPOSAL

Sludge is usually disposed of on land as manure to soil, or as a soil conditioner, or barged into sea. Burial is generally resorted to for small quantities of putrescible sludge. The most common method is to utilize it as a fertilizer. Ash from incinerated sludge is used as a landfill. In some cases, wet sludge, raw or digested, as well as supernatant from digester can be lagooned as a temporary measure but such practice may create problems like odour nuisance, ground water pollution and other public health hazards. Wet or digested sludge can be used as sanitary landfill or for mechanized composting with city refuse.

17.5.1 Sludge as Fertilizer

The use of raw sludge as a fertilizer directly on land for raising crops as a means of disposal is not desirable since it is fraught with health hazards. Application of sewage sludges to soils should take into consideration the following guiding principles:

- i) Sludge from open air drying beds should not be used on soils where it is likely to come into direct contact with the vegetables and fruits grown
- ii) Sludge from drying beds should be ploughed into the soil before raising crops. Top dressing of soil with sludge should be prohibited
- iii) Dried sludge may be used for lawns and for growing deep rooted cash crops and fodder grasses where direct contact with edible part is minimum
- iv) Heat dried sludge is the safest from public health point of view. Though deficient in humus, it is convenient for handling and distribution. It should be used along with farmyard manure
- v) Liquid sludge either raw or digested is unsafe to use. It is unsatisfactory as fertilizer or soil conditioner. If used, it must be thoroughly incorporated into the soil and land should be given rest, so that biological transformation of organic material takes place. It should be used in such a way as to avoid all possible direct human contact.

In general, digested sludges are of moderate but definite value as a source of slowly available nitrogen and some phosphate. They are comparable to farmyard manure except for deficiency in potash. They also contain many essential elements to plant life and minor nutrients, in the form of trace metals.

The sludge humus also increases the water holding capacity of soil and reduces soil erosion making an excellent soil conditioner specially in arid regions by making available needed humus content which results in greater fertility.

17.5.2 Sludge Lagooning

Use of sludge lagoons for storage, digestion, dewatering and final disposal of dried sludge may be adopted in isolated locations where the soil is fairly porous and when there is no chance of ground water contamination. Drainage water should not be allowed to enter the lagoon. The depth of lagoon and its area should be about twice that required for sand drying under comparable conditions. Depth may range from 0.5 to 1.5 m. Lagoons have been used for regular drying of sludge on a fill and draw basis or allowed to fill dry and then levelled out and used as lawns. Lagoons have also been employed as emergency storage when digesters have to be emptied for repairs. As they are less expensive to build and operate, they have been resorted to, particularly for digested sludge in areas where large open land suitably located is available. Use of lagoons is not generally desirable, as they present an ugly sight and cause odour and mosquito breeding.

17.5.3 Land Fill

When organic solids are placed in a land fill, decomposition may result in odour if sufficient cover is not available. Besides surface water contamination and leaching of sludge components to the ground water must be considered. Decomposition may result in soil settlement resulting surface water ponding above the fill. Typical depths of soil cover over the fill area are 0.2 m after each daily deposit and 0.6 m over an area that has been filled completely.

Surface topography should be finished to allow rainfall to drain away and not allow it to infiltrate into the solid land fill.

Land fill leachate requires long term monitoring and should satisfy water pollution standards. Vegetation must be established quickly on completed areas to provide for erosion control. It is general practice not to crop the land fill area for a number of years after completion.

Land fills are not usually recommended for disposal of sludge. In case they are adopted the above points should be considered.

17.5.4 Disposal in Water or Sea

This is not a common method of disposal because it is contingent on the availability of a large body of water adequate to permit dilution. At some sea coast sites the sludge, either raw or digested, may be barged to sea far enough to make available the required dilution and dispersion. The method requires careful consideration of all factors for proper design and siting of outfall to prevent any coastal pollution or interference with navigation.

CHAPTER 18

SLUDGE PUMPING

18.1 GENERAL CONSIDERATIONS

Pumping is important in handling sludge, because sludge produced in the different units of a sewage-treatment plant has to be moved from point to point.

The selection of a pump depends upon the type of sludge to be handled, viz. whether the sludge is primary, secondary, return, elutriated or thickened and concentrated. The sludge may be watery, thick or occasionally scum. Sludge is more viscous than water. An important characteristic of the different types of sludges is the percentage content of the suspended solids, as summarised in Table 18.1.

TABLE 18.1

SOLIDS IN DIFFERENT TYPES OF SLUDGES

Type of Sludge	% of Solids
Raw Primary Sludge	4 to 8
Secondary Sludge	1 to 5
Raw Primary and Secondary Sludge	3 to 8
Digested Sludge	6 to 10
Chemical Sludge	4 to 12
Alum and Ferric Sludge	2 to 6
Chemical Slurries	1 to 30
Incinerator as slurries	5 to 20

18.2 SLUDGE-PUMPING

Sludge pumping may be intermittent or continuous, depending upon the type and design of the waste-treatment processes and of the sludge-handling and treatment units.

Pumping of sludge is required in the following situations :-

- i) for transfer of the sludge from the sedimentation tanks to thickeners and/or digesters
- ii) for recirculation of secondary sludge
- iii) for transfer of excess sludge from secondary biological treatment units to thickeners and/or digester or to primary settling tanks
- iv) for carrying sludge from extended aeration system directly to drying beds
- v) for disposal of sludge into lagoons or on land

18.3 SLUDGE PUMPS

Sludge-pumps have to be resistant to abrasion as sludges quite often contain sand and grit. The sludge-pumps should be slow speed machines to contain the rate of wear and tear.

Since a sludge-pump may have to run intermittently or continuous, a sludge-pump has to be dependable in respect of satisfactory trouble-free operation, whether under the fatigue of the intermittent operation or with the endurance desired for long continuous operation.

The type of pumps generally used for pumping sludges are:

- i) Centrifugal pumps
- ii) Air Lift pumps
- iii) Screw pumps
- iv) Reciprocating pumps of the plunger type or of diaphragm type

Table 18.2 shows the typical applications of pumps of these different types and the types of sludges handled by them.

TABLE 18.2
TYPICAL APPLICATIONS OF SLUDGE PUMPS

Type of Pump	Max. Suction Lift (m)	Max. % Solids generally handled	Typical applications
Centrifugal			
(a) non-clog	4.5	2	Primary settled sludge, secondary settled sludge, chemically treated sludge, incinerator slurries
(b) vortex flow	4.5	6	Sludge recirculation
Air Lift	0	6	Return sludge
Screw Pump	0	6	Return sludge
Positive displacement, plunger or diaphragm pump	6.5	10	Primary settled sludge, thickened sludge, digested sludge, incinerated sludge, heat conditioned sludge, chemically treated sludge, slurries

There are specific considerations to be borne in mind in the use of the different types of pumps for handling sludge.

18.3.1 Centrifugal Pumps

The centrifugal pumps for handling sludge must be of the non-clog type. They should be of robust construction and should have easily accessible hand-holes for cleaning. Pumps of the macerator type impeller with a cutting ring whereby stringy rags and other fibrous material can get cut, are preferable.

When the specific speed of the pump would be low, the non-clog impellers are designed with fewer number of blades than in impellers for handling clear liquids. In pumps of high specific speed, the mixed flow impeller would generally have wide passages. The centrifugal pumps with non-clogging impellers have less efficiency than those of normal design, handling clear liquids. The rating for the drive-motor has to be selected keeping this in mind.

The specific speed of the pump also affects the suction-lift capability of the pump. This can be overcome by selecting a vertical centrifugal pump to be so installed that the impeller would be adequately submerged.

18.3.2 Air-Lift Pumps

These are used in small extended aeration plants to return the sludge and scum to the aeration tank. Small air bubbles are formed in the liquid, which makes the air-water mixing less dense to get lifted to the discharge point. A compressor or blower supplies the air.

Air-lift pumps and ejectors are pumping systems, which are inherently inefficient. However, there being no moving parts in the path of the movement of the sludge, their operation is fairly trouble-free.

18.3.3 Screw Pumps

Sludge enters the screw pump by a 'screw conveyor', which moves solids to an open impeller, which lifts them to the point of discharge. The submerged lower bearing is of the enclosed and sealed type, the upper bearing is usually grease-lubricated, anti-friction bearing.

A variation of the screw pump is a progressive cavity pump. It has a rubber stator or lining inside a cast iron body. The pumping element is a helical rotor of steel. Although the pump has self-priming capability, the rotor must never run dry against the rubber stator. The pump can pump up or down depending upon the direction of rotation.

18.3.4 Reciprocating Plunger or Diaphragm Pumps

- a) The Plunger type pumps have a plunger reciprocating in a cylinder. A pump can have one or more plungers connected to common crankshaft, thereby obtaining arrangements called simplex, duplex, triplex, etc. Reciprocating pumps may be with capacities of the order of 150 to 250 lpm per plunger. The pump-speeds should be between 40 to 50 rpm. Reciprocating pumps are self-priming and can usually work with suction-lifts upto 3 m. The suction-lift capability depends upon the design of the pump, especially of the suction valve.

The pumps can develop high heads and are hence suitable where accumulation of grease in piping can cause progressive increase in head. However if the piping is likely to get completely choked, the pumps would develop very high pressures against choking and this can cause bursting. A relief valve is provided to protect the pump in case of a clogged delivery line. After each use, the pump should be flushed, so that no solids settle in the cylinder and would damage the pump during the next starting.

The suction and delivery valves are the main source of trouble. The valves should be easily accessible for quick cleaning, in case the valves fail to seat properly.

- b) The diaphragm pumps have a flexible diaphragm, usually of rubber and actuated by a reciprocating movement. The diaphragm is fastened peripherally to the casing, which also houses the suction and delivery valves. The interesting feature of the diaphragm pumps is that the components of the reciprocating mechanism, which are the most wear-prone, are isolated from the path of the sludge. Pneumatic or hydraulic drives can also be employed for the reciprocating movement.

18.4 OPERATIONAL PROBLEMS

- a) Gas often gets liberated, when the sludge, particularly the digested sludge is subjected to suction. This hampers the proper operation of the pump. The pumps should be installed, as far as possible, with positive suction.
- b) If the suction arrangements are improperly designed, a vortex-cone or hole developing in the sludge blanket will cause the watery sludge or supernatant to be pumped instead of the sludge. The suction pipe should not be too long, nor should the pumping be too long or too fast. It is better to pump more often than at reduced speed. With a pump equipped with variable speed drive, the pump can be started at a relatively high speed and the speed can then be reduced.
- c) Sludge from two settling tanks should not be connected to the suction of one pump. The settling tank with the thinner sludge will get pumped and the thickened sludge in the other tank will not get pumped. Similar problem will happen, if the suction lines from the two tanks will have differential frictional losses. The tank with higher frictional loss in its suction piping, which may be because of more length or because of choking, will not get pumped.

The capacity of sludge pumps is required to be regulated according to the sewage load. Further, variable speed drives are more appropriate for regulating, because having delivery valves in the sludge-pumping system makes an inefficient and trouble-prone system.

18.5 REQUIREMENT OF STANDBY UNITS

The number of pumping units required including the standbys is determined by several factors like the particular function involved, the size of the plant and the arrangement of the units, especially having combination of more than one function. A minimum stand by capacity of 50% is recommended.

Since primary and secondary sludge pumping are important functions, standby pumps are provided in actual numbers or by such arrangement that dual duty is possible. Scum is usually mixed with the primary sludge and pumped.

18.6 SLUDGE CONVEYING PIPING

After selecting the type of pump, the next important thing is to design the pipeline to and from the pumps. The design of the piping is to be based on the rate of sludge-handling, the desired velocity of the flow of the sludges, the possible layout and arrangement of the piping etc. Reference may be made to Table 22.2, regarding piping material. The material for piping and valves should be corrosion and abrasion resistant.

Sewage sludge flows like a thin plastic material and hence the formulae for the flow of water are not applicable. The velocity of flow should be in the critical range above the upper limit of the laminar flow and below the lower limit of the turbulent flow, in order to avoid clogging and deposition of grease, so that the application of the hydraulic formulae for flow of water become permissible. In general velocities between 1.5 to 2.5 m/s are satisfactory. The frictional head losses in the sludge pipe can be estimated by applying the Hazen-William's formula, adopting the 'C' value between 40 to 50 depending upon the material to used; the lower value being adopted for high solid content of the sludge.

Pipes less than NS 200 should not be used for gravity withdrawal or for the suction lines to pumps. In order to take care of thin sludge to flow by gravity for short distances within the treatment plant, a 3% or greater slope should be adopted.

Suction and discharge should be arranged in such a way that their lengths are as short as possible, straight and with minimum bends. Adequate provision should be made to facilitate cleaning. Large radius elbows and sweep tees are usually adopted for change in direction. High points should be avoided, as far as possible, to prevent gas pockets. Suitable recess and sleeves are usually provided for all pipes passing through masonry. Double-flanged pipes are usually adopted for sludge-lines, providing valves at selected locations to clean the lines.

18.7 PUMP APPURTENANCES

The performance of the sludge pumps can be more efficient and its assessment and control can be better, if various appurtenances, such as air chambers, sampling devices, measuring devices, valves, gauges are incorporated in the system and facilities such as revolution counters, gland seals, time clocks, etc., are kept available at the plant.

18.7.1 Air Chamber

Air chamber of adequate size is necessary for all plunger type sludge pumps on the discharge side of the pump. It may also be provided on the suction side of the pumps, particularly where positive suction head exists. Such chambers absorb the shock of plunger pump pulsations.

18.7.2 Revolution Counter

Plunger-type sludge pumps should be equipped with revolution counters or integrating recorders to help the operator to determine the quantity of sludge pumped. In duplicate pump installations these aid in equalising the service and wear of each pump.

18.7.3 Gland Seals

In the case of centrifugal pumps, external sealing is provided in the stuffing box, to ensure against the ingress of air into the pump. The external sealing may be a grease seal or water seal. The water seals are preferable, as it also helps the grit and dirt to be washed away. The water to the water-seal has to be potable water. However, the connection of potable water should not be taken directly from the supply lines.

18.7.4 Valves

When a dry pit pump has positive suction head in the wet well, there should be a isolating valve, usually a gate-valve, on the suction line, to facilitate isolating the pump for maintenance.

On the delivery side of centrifugal pumps, a non-return valve is necessary, so that the pump would not experience the back-pressure from the delivery head, when the pump is to be shut off. To minimise the pressure-drop across the valve, during the normal running of the pump, the non-return valve should be of the swing-check type or of the ball-check type. To avoid water-hammer, which is likely to be caused by the closure of the valve, the valve may be provided with an anti-slam device, either of the lever and dead-weight type or of the spring-loading type or of the dash pot type. Dual check valves are sometimes used, which gives more consistent operation and facilitates the use of the pump as metering device. All the valves may be provided with drain plugs.

In larger size plants, where pumps may be run in parallel operation with different permutation of the standbys, isolation valves would be needed to isolate those pumps, which are to be idle. Mostly the isolating valves are gate valves. All gate valves should preferably be of the rising stem type, since they offer the advantage of visual indication of the valve-position. For exterior underground locations, gate valves are generally used. Underground sludge valves should be avoided as far as possible, by taking advantages of the hydrostatic pressure for withdrawal of sludge through a slant pipe and valve arrangement.

18.7.5 Gauges

Pressure gauges shall be provided on both the suction and delivery sides. For pumps having suction lift, the gauge on the suction side should be a composite vacuum-cum-pressure gauge. The gauges should be with a cast iron bowl and an oil-resistant rubber diaphragm, which would keep the sludge away from the finer working parts of the gauges.

18.7.6 Sampling Devices

All sludge pumps are provided with sampling cocks, either within themselves or in the piping adjacent to the pump. These are usually plug valves, normally of size NS 40. Plug valves are simple and easy to operate for taking the samples.

18.7.7 Washouts and Drains

Washout or flushing arrangements are provided for sludge pumps to facilitate easy and rapid cleansing. The drains on the pump body should be of ample size to ensure release of pressure and drainage of the liquid. The outlet of the drain should be connected to an adjacent floor drain to keep the floor clean.

18.7.8 Time clocks

Time clocks, wired across the magnetic starters or motor leads of sludge pumps can be valuable help to the operators. They help to keep an accurate record of the hours of run of the pump for observing the preventive maintenance schedules in respect of attending to the lubrication, equalisation of wear and tear, etc.

18.7.9 Measuring Devices

While time clocks and counters are adequate for small plants, supplementary flow-metering arrangements, such as flow tubes with flushing provisions are used in large plants for measuring and recording the quantities of sludge handled. Magnetic meters are more suitable for sludge metering.

18.8 PUMP DRIVE EQUIPMENT

The prime movers for the pumps are usually the electric motors, which are discussed in detail in 9.8. It is desirable to use flame proof motors.

I.C. Engines may be used for standby services in the case of failure of electric power. Again, the I.C. Engines are better used as prime mover for a standby generator than as a prime-mover for the pumps, because the standby generator can then provide the power for lighting and ventilation facilities.

Gas engines using sludge gas as fuel, would help not only as the standby power supply facility but also as an effective method of energy-conservation in the operation of the plants.

CHAPTER 19

TERTIARY TREATMENT OF SEWAGE FOR REUSE

19.1 GENERAL

Tertiary treatment is supplementary to primary and secondary treatment for the purpose of removing the residual organic and inorganic substances and in some cases even the refractory and dissolved substances to the degree necessary.

Tertiary Treatment of sewage is increasingly being adopted in India. Some of the purposes for which it can be considered are

- industrial reuse of the reclaimed water in cooling systems, boiler feed, process water etc.
- reuse in agriculture, horticulture, pisciculture, watering of lawns, golf-courses and such purposes.
- Ground water recharge for augmenting ground water resources for downstream users or for preventing saline water intrusion in coastal areas.

As more such applications are likely to be made in the future, this subject has been included in the manual for general guidance.

19.2 BASIC APPROACH

When water is used once by a community, various organic and inorganic substances are added to those already contained in the fresh municipal water supply. The concentration of additional constituents can be estimated from the extent of water supplied in lpcd and the likely contribution of each constituent some of which are given in Table 19.1 in grams/person/day. In this manner, the composition of raw sewage expected from one-time use of water by a community can be computed.

During primary and secondary treatment of sewage many constituents, though not all, undergo reduction in concentration. Some dissolved and refractory (non-degradable) substances, are however, not reduced at all.

Tertiary treatment provides only the additional treatment necessary to meet the desired end use. Thus, tertiary treatment is quite use-specific and may involve only one item like simple chlorination of treated sewage or several items as in the case of high pressure boiler feed water.

It is, therefore, very important that clear-cut specifications of the reusable water are first obtained.

In spite of a high degree of treatment achieved in all cases, water is reclaimed only for non-potable uses. In fact, the actual quality may be comparable to that of drinking water but any attempt to supply potable water directly would only meet with psychological resistance from the public and might even present some problems since the full public health significance of direct reuse over a long period of time is not yet known. Indirect use of reclaimed water for potable uses through ground water recharge is no doubt, feasible as the applied water loses its identity in underground travel and, in fact, benefits from natural purification in downstream flow through soil. Indirect reuse systems based on treated sewage have not yet been implemented in India in any planned manner.

TABLE 19.1
DOMESTIC WASTE WATER CHARACTERISTICS

Item	Range of Values contributed in wastes (gpcd)
BOD ₅	45 - 54
COD (dichromate)	1.6 to 1.9 x BOD ₅
Total Organic Carbon	0.5 to 1.0 BOD ₅ (Soluble)
Total Solids	170 - 220
Suspended Solids	70 - 145
Grit (inorganic 0.2 mm and above)	5 - 15
Alkalinity, as CaCO ₃	20 - 30
Chlorides	4 - 8
Nitrogen, total, as N	6 - 12
Organic Nitrogen	0.4 x Total N
Free Ammonia	0.6 to Total N
Nitrate Nitrogen	absent
Nitrite Nitrogen	absent
Phosphorus, total, as P	0.8 - 4.0
Organic phosphorus	0.3 x Total P
Inorganic (ortho and Polyphosphates)	0.7 x Total P
Potassium, as K ₂ O	2.0 - 6.0

19.3 TERTIARY TREATMENT METHODS

Tertiary treatment methods are mostly physico-chemical in nature, some examples of which are given below:

- Disinfection
- Oxidation
- Chemical dosing for water quality correction
- Chemically aided settling
- Filtration
- Softening

Activated carbon treatment

Anion/Cation exchange (demineralization)

Reverse Osmosis.

A tertiary treatment plant, therefore, generally, looks like a sewage treatment plant followed by a typical industrial water treatment plant.

Table 19.2. gives the range of removal of impurities that can be expected in sewage treatment using different combinations of different processes.

TABLE 19.2
PROGRESSIVE REMOVAL OF IMPURITIES IN SEWAGE TREATMENT

St. No.	Process	% Removal based on raw waste concentration						
		B.O.D.	Phosphates	Nitrogen	ABS*	Suspended Solids	T.D.S	Colifomrs
1	Conventional Sewage Treatment	90	40-50	40-50	50	90	5	95 - 99
2	Conventional Sewage treatment + lime - alum coagulation, settling filtration	93-95	95	50	50 - 55	99	10	99 - 99.9
3	2 above + absorption on activated carbon	99	95	50- 55	95	99	15	99 - 99.9
4	3 above + demineralization or Reverse Osmosis	99	97	75	98	99	80 Further removed by demineralization	99.9 - 100

* ABS - Alkyl Benzene Sulphonate

19.4 DESIGN CRITERIA

In designing a tertiary treatment system for any purpose the crux of the problem lies in determining what specific treatment units will be required, and in what sequence to achieve the desired end-use quality. The capability of each individual treatment unit is generally known from experience. The range of efficiency a unit can achieve in practice as well as the conditions (e.g. concentration, fluctuation, temperature, etc.) under which it can function best are fairly well known, and the required flow sheet can thus be synthesized to give the overall degree of treatment required.

Once the flow sheet is determined, the actual design criteria to be used for each individual treatment step in the flowsheet are the same as those already given in the other chapters of this Manual and the Manual on water supply and treatment. As stated earlier, the critical aspect is to determine the tolerable level of impurities in the final water depending on the reuse planned.

Some important considerations in selecting tertiary treatment methods for various industrial and agricultural purposes are discussed below.

19.5 REUSE FOR INDUSTRIAL PURPOSES

Reuse for industrial purposes generally includes

- make up water required for cooling towers
- boiler feed water for raising steam or hot water
- water for selected unit processes and unit operations in the industry.

The wastewater to be reclaimed for industrial reuse may come from one or more of the following sources :

- sewage from toilet blocks and washing places within factory campus and from housing colony areas
- municipal sewage from public sewers serving the city area i.e. sewage from off-site sources
- wastewaters from certain selected processes and operations within the factory.

In choosing the source of wastewater it is important to select wastewater which are readily treatable (e.g. sewage from domestic sources) and which do not contain difficult industrial wastes in them especially the difficult-to-remove dyes, heavy metals, refractory chemicals, etc. Treatment as such is possible even if the wastewaters are polluted by such substances, but the costs on quality control instrumentation may prove discouraging.

A few industrial reuse examples are give below.

19.5.1. As Cooling Water

Reuse as cooling water is one of the most common industrial applications of reclaimed sewage water. Typical guidelines for cooling water quality are given in Table 19.3 and may be used where specific requirements are not given.

To determine the quality and quantity of water required for reuse in a cooling system, where an open recirculating system is adopted for air conditioning cooling water, the amount of water to be kept recirculating in the system is approximately 11 lpm for every ton of refrigeration capacity when the temperature drop is 5 degrees C. in the cooling tower. For such a situation, the water lost in evaporation (E) is about 1% of the recirculating water.

Windage loss (W) is of the order of 0.1 to 0.3% of the recirculating water when mechanical draft towers are used, but increases to 0.3 to 1.0% for atmospheric towers. Blowdown requirement (B) is estimated from the following equation if the maximum permissible cycles of concentration (C) are known

$$B = \frac{E + W(1 - C)}{C - 1}$$

Where B, E and W are all in lpm.

For trouble free operation and minimum use of water quality- control chemicals in the recirculating water, the cycles of concentration are generally kept at 2.0 to 3.0 and, in no case, more than 4.0 in cooling towers where reclaimed water is used (Table 19.3). Hence, for a 100-ton air-conditioning plant recirculating 1100 liters/min of water with a temperature drop of, say 10 degrees C through a mechanical draft tower where cycles of concentration are to be restricted to 2.0

$$E = 2\% \times 1100 = 22 \text{ lpm.}$$

$$W = 0.2\% \times 1100 = 2.2 \text{ lpm.}$$

$$B = \frac{22 + 2.2(1 - 2)}{(2 - 1)} = 20 \text{ lpm (approx.)}$$

The total make-up water requirement thus equals 44.2 lpm (= 22 + 2.2 + 20) or 63.4 cum/day for 24 hr. working of a 100-ton plant.

TABLE 19.3
COOLING WATER QUALITY GUIDELINES

PARAMETER / CONDITION		RECOMMENDED VALUE
(A)	In make-up water	
1.	pH	6.8 - 7.0 (Variation less than 0.6 units in 8 hours)
2.	Average TDS value (with variation - 25% permissible on 8 hour average)	Cycles of concentration in recirculating water
	3000 mg/l	2.0
	1000 mg/l	3.5
	500 mg/l	6.0
3.	Oil & Grease	Absent
4.	BOD (5 day, 20 degrees C)	Less than 5.0 mg/l
5.	Chlorides (Cl)	Less than 175 mg/l
6.	Ammonia	No appreciable amount
7.	Caustic Alkalinity	Absent
8.	Methyl Orange Alkalinity (as CaCO ₃)	Less than 200 mg/l
B)	In Recirculating Water:	
9.	Silica (as SiO ₂)	Less than 150 mg/l
10.	Phosphates, Sulphates	Not to exceed solubility limit in recirculating water
11.	Alkyl Benzene Sulphonate (ABS)	Foam not to persist more than 1 min after 10 secs of vigorous shaking or recirculating water
12.	Langelier Index at Skin temperature of heat exchange surface	0.5 ± 0.1
13.	Ryzner Stability Index	6.0 to 7.0

Similarly, if 3.0 cycles of concentration are permissible, the total requirement of make-up water reduces to 47.7 Cum-day for a 100 ton plant.

When cycles of concentration equal 3.0, the various stable constituents (e.g. chlorides) in make-up water are theoretically increased by a factor of 3.0 in the recirculating water. If the concentration of various constituents in the make-up water lie within the range of values given in column (F) of Table 19.4 the corresponding concentration in the recirculating water can be readily estimated. For example, if Cl are 60 mg/l in the make-up water, they will increase to 180 mg/l in the recirculating water. However, the pH of the recirculating water cannot be estimated in this manner. The assumption is frequently made that in the absence of phenolphthalein alkalinity, the pH of the water leaving the cooling tower will be between 8.0 and 8.3 due to elimination of free carbon dioxide in the tower. Sometimes, for other reasons, a lower or higher pH may be observed. Thus knowing the pH, the concentrations of calcium, alkalinity and total dissolved solids in the recirculating water, and the temperature in the hottest part of the system, one can determine the Langelier Index and Ryzner Stability Index and not the tendency of the water to scale or corrode. Assuming that the recirculating water shows the tendency for deposition of scale, reduction in hardness and in alkalinity is the usual means of control. Since nothing can be done to reduce temperature, and reduction in total solids would not have much effect on the Index

For this reason, partial zeolite softening (by blending the softened water with by-passed hard water), plus acid feeding if required for reduction of alkalinity provide a relatively simple and flexible means of preventing excessive scaling in this type of installation. The blending ensures a certain amount of hardness in the water which is useful to protect against corrosion of ferrous heat exchanger surfaces. The acid treatment (using H_2SO_4) depends for its functioning on the fact that calcium and magnesium sulfates are much more soluble than the carbonates, with the usually adopted dosages and the cycles of concentration obtaining in the system, calcium sulfate concentrations obtaining in the system. Calcium sulfate concentrations are well below the solubility limit. Similarly, calcium phosphate is also kept within the solubility limit.

Automatic dosing and control equipment is normally not provided in plants in India. The clear water storage tanks helps to maintain uniformity of quality of water pumped to the cooling towers. Storage ensures that pH, total dissolved solids, etc., do not vary much from hour to hour, and the wide variations in inflow quantities are balanced out.

Prechlorination is done as the water enters the coagulation tanks, while postchlorination is mainly in the form of periodic "shock" doses to control lime and algal growths. The latter are likely to form owing of the presence of nitrates and phosphates in the treated water and the warm and sunny climate of India.

A typical flowsheet for making sewage water fit for reuse as cooling water is given in Fig 19.1. Table 19.4 gives an illustrative example of the change in water quality as fresh municipal water becomes wastewater and is gradually renovated for reuse as cooling and process water.

Where nitrates and phosphates in the make-up water are necessary to be reduced, the biological treatment given to wastewater at the secondary stage can itself be modified to include nitrification - denitrification and the addition of lime done in the final settling tank to precipitate phosphates.

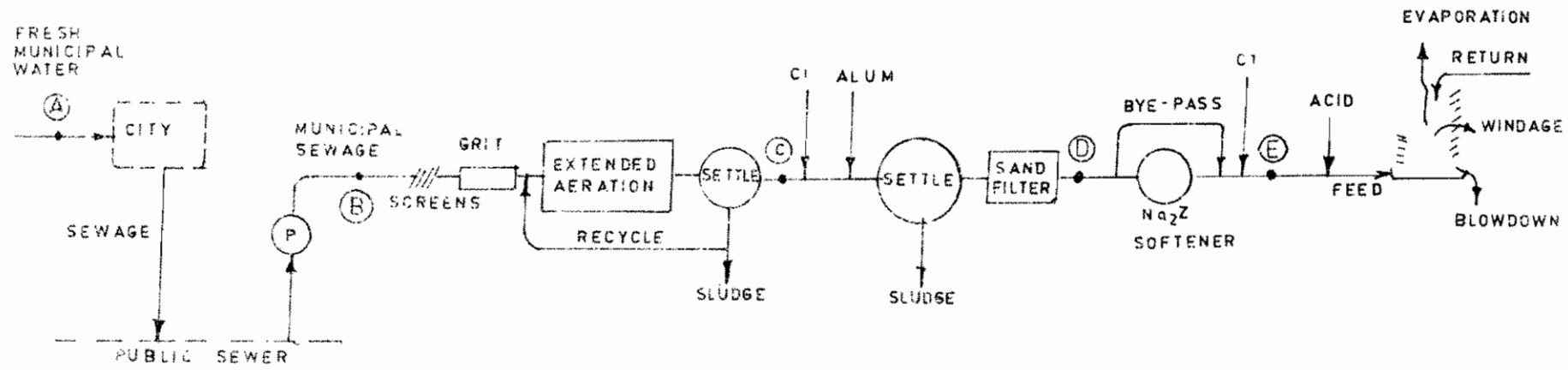

309

FIG.19.1: FLOWSHEET FOR TREATMENT OF MUNICIPAL WASTE WATER FOR REUSE AS COOLING TOWER MAKE - UP WATER

TABLE 19.4
THE RANGE OF CHANGE IN WATER QUALITY AS FRESH WATER BECOMES WASTEWATER AND IS GRADUALLY
RENOVATED FOR REUSE
(ILLUSTRATIVE EXAMPLE)

Item	Fresh Municipal Water	Raw Domestic Sewage from the area	Water quality at different treatment steps			
			After extended aeration and settling	After coagulation and filtration	After softening and chlorination	After demineralization
	(A)	(B)	(C)	(D)	(E)	(F)
pH	7.6-7.8	7.15-7.65	7.2-7.8	7.1-7.3	7.1-7.2	8.75
Total Hardness (mg/l as CaCO ₃)	35 - 40	120 - 160	120 - 160	120 - 170	40 (a)	Nil
M.O. Alkalinity (mg/l as CaCO ₃)	40 - 45	125 - 200	125 - 200	110 - 180 (b)	110 - 180	5.0
Chlorides mg/liter as Cl	15 - 20	60 - 130	60 - 120	60 - 130	60 - 130	Nil.
Sulfates mg/l as SO ₄	1.5 - 2.5	10 - 20	10 - 15	15 - 25	15 - 25	Nil.
Phosphates mg/l as PO ₄	Traces - 0.1	6 - 16	3 - 5	0.2 - 0.5	0.2 - 0.5	Nil.
Nitrates mg/l as NO ₃	1.0 - 2.0	1.0 - 3.0	13 - 19	13 - 19	13 - 19	Nil.
Silica mg/l as SiO ₂	8 - 24	10 - 24	10 - 24	10 - 20	10 - 20	Nil
Total solids mg/l	80 - 90	500 - 800	300 - 500	300 - 450	320 - 480	5.0
Suspended solids mg/l	5 - 10	150 - 250	15 - 30	Nil.	Nil.	Nil.
Turbidity, SiO ₂ Units	5 - 10	Turbid	10 - 20	2.0 - 3.0	2.0 - 3.0	0.2
BOD ₅ days 20 deg C mg/l	0.1 - 1.5	200 - 250	6 - 10	1.0 - 2.0	1.0 - 1.5	Nil.
COD, mg/l	1.0 - 2.0	250 - 350	16 - 40	4 - 6	3.5 - 5.0	Nil
Bacteriological quality (as per coliform standards)	Safe	UnSafe	Unsafe	Safe	Safe	-
Specific conductance	-	-	-	-	-	10 Microbes

- a) Softened water is blended with unsoftened water to give a final hardness of 40 mg/l as in fresh municipal water.
- b) Alkalinity is reduced by acid treatment just prior to use in cooling towers. This increases sulfate content somewhat since H₂SO₄ is used.

19.5.2 As Boiler Feed Water

Reuse as boiler feed water may require additional treatment over that required for cooling purposes. As boiler feed, the quality of water depends on the boiler pressures at which steam is to be raised. The higher the boiler pressure, the purer the water required.

Table 19.5 gives an indication of the water quality required for low and medium pressure boilers. For low pressure boilers, the quality of water required is more or less similar to that for reuse in cooling purposes. For high pressure systems, the treatment required can be quite substantial as can be seen from the water requirements given in Table 19.6. A typical flowsheet given in fig 19.2 includes tertiary treatment in the form of chlorination, chemically aided sedimentation, sand filtration, sodium zeolite softening followed by cation exchange on hydrogen cycle, degassification and weak base anion exchange to give practically complete demineralization.

TABLE 19.5
CHEMICAL REQUIREMENTS OF FEED WATER AND BOILER WATER
FOR LOW AND MEDIUM PRESSURE BOILERS

Sl No.	Characteristic	Requirement for Boiler Pressure			Method of Test (ref to CL No of)	
		Upto 2.0 Nm ² /sq m	2.1 to 3.9 Nm ² /sq m	4.0 to 5.9 Nm ² /sq m	IS 3550 1965 (a)	IS 3025 1964 (b)
1	Feed Water					
	a) Total hardness (as CaCO ₃) mg/l Max	10	10	0.5		16.1
	b) pH Value	8.5 to 9.5	8.5 to 9.5	8.5 to 9.5	-	8
	c) Dissolved Oxygen mg/l, Max	0.1	0.02	0.01	25	
	d) Silica (as SiO ₂) mg/l, Max		5	0.5	16	-
2.	Boiler Water					
	a) Total hardness (of filtered sample) (as CaCO ₃) mg/l, max	NOT DETECTABLE				16.1
	b) Total alkalinity (as CaCO ₃) mg/l Max	700	500	300		13
	c) Caustic alkalinity (as CaCO ₃) mg/l Max	350	200	60		15
	d) pH value	11.0 to 12.0	10 to 12.0	10.5 to 11.0		6
	e) Residual sodium sulphite (as Na ₂ SO ₃) mg/l	30 to 50	20 to 30	-		21
	f) Residual Hydrate zinc (as ZnO) mg/l	0.1 to 1 (if added)	0.1 to 0.5 (if added)	0.5 to 0.3	26	
	g) Ratio Na ₂ SO ₃ caustic alkalinity (as NaOH)		above	2.5		20.2 and 15
	or					
	Ratio NaNO ₃ total alkalinity (as NaOH)		above	0.4		46 and 13

- a) Methods of Test for routine control for water used in Industry
 b) Methods of sampling and test (Physical and Chemical) for water used in Industry.

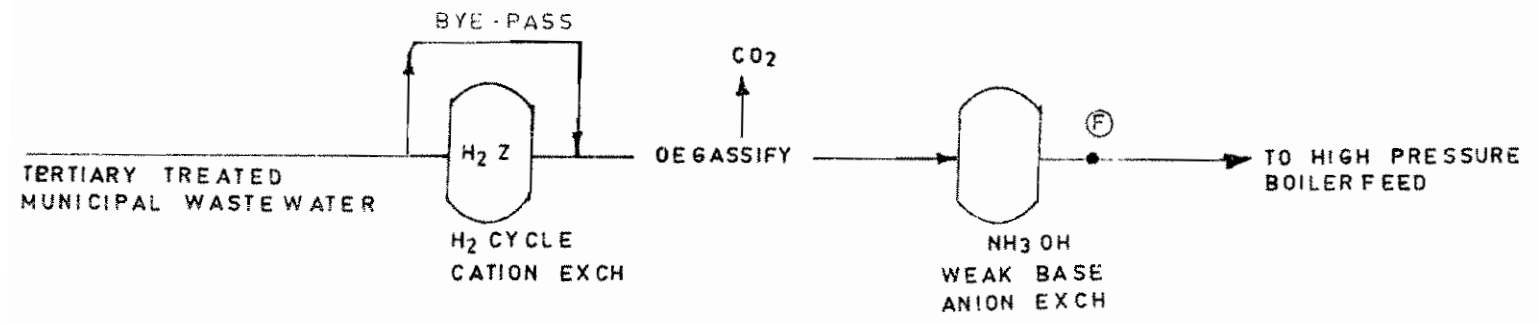

FIG.19.2: FLOW SHEET FOR REUSE OF WASTE WATER AS HIGH PRESSURE BOILER FEED

TABLE 19.6
REQUIREMENTS FOR FEED WATER, BOILER WATER AND CONDENSATE FOR WATER-TUBE BOILERS (DRUM TYPE)

Sl No	Characteristic	Requirements for Pressure (in MPa) of the drum				Methods of test to Cl. No. of		Ref. and Cl. No.
		0.1 - 1.0	1.0 - 9.8	9.8 - 11.8	above 11.8	IS 3550 1965 (IS)	IS 3025 1962 (IS)	
1	Total Hardness (as CaCO ₃) mg/l Max	N ^o	N ^o	N ^o	N ^o		16.1	
2	pH value (see also Note 1)	8.5 - 9.5	8.5 - 9.5	8.5 - 9.5	8.5 - 9.5		4	2.1 (1a)
3	Oxygen (as O ₂) mg/l Max	0.01	0.05	0.1	0.2	2		2.1 (1b)
4	Iron + Copper mg/l Max	0.05	0.1	0.1	0.1	See A 1.3 of A 5.4 method of test		2.1 (1c)
5	Silica (SiO ₂) Max	0.05	0.1	0.1	0.2	See A 1.3 of method of test		2.1 (1d)
6	Oil mg/l Max	N ^o	N ^o	N ^o	N ^o		50	
7	Residual hydrazine (as N ₂ H ₄) mg/l max	0.05	0.05	0.05	0.05	2b		
8	Conductivity after passing through cation exchange column at 25 deg C microsiemens/cm Max	0.5	1.5	1.5	0.3	2		
9	Oxygen consumed in 4 hours mg/l Max (see also Note 2)	N ^o	N ^o	N ^o	N ^o		5.1	

- a) Methods of test for routine control for water used in Industry.
- b) Methods of sampling and test (physical and chemical) for water used in Industry.

19.5.3 As Process Water

In order to keep treatment to a minimum for reuse as process water, one benefits from identifying those processes which must have fresh waters of high quality and those processes which can do with reclaimed water of low quality (e.g. similar in quality to that used for cooling or for low pressure boilers). This is done by having a multiple quality water supply system within the industry (Fig 19.3).

Indian standards for quality tolerances for a few industrial uses are noted below :

- IS 201 : 1964 Quality tolerances for water for textile industry.
- IS 2724 : 1964 Quality tolerances for water for pulp and paper industry.
- IS 3957 : 1966 Quality tolerances for water for ice manufacture.
- IS 4251 : 1967 Quality tolerances for water for processed food industry.
- IS 4700 : 1968 Quality tolerances for water for Fermentation industry.

It may be noted that generally all the processes in an industry do not require water of the relatively high quality given in the above noted Indian Standards. There are always several unit processes and operations where water of lesser quality can be tolerated.

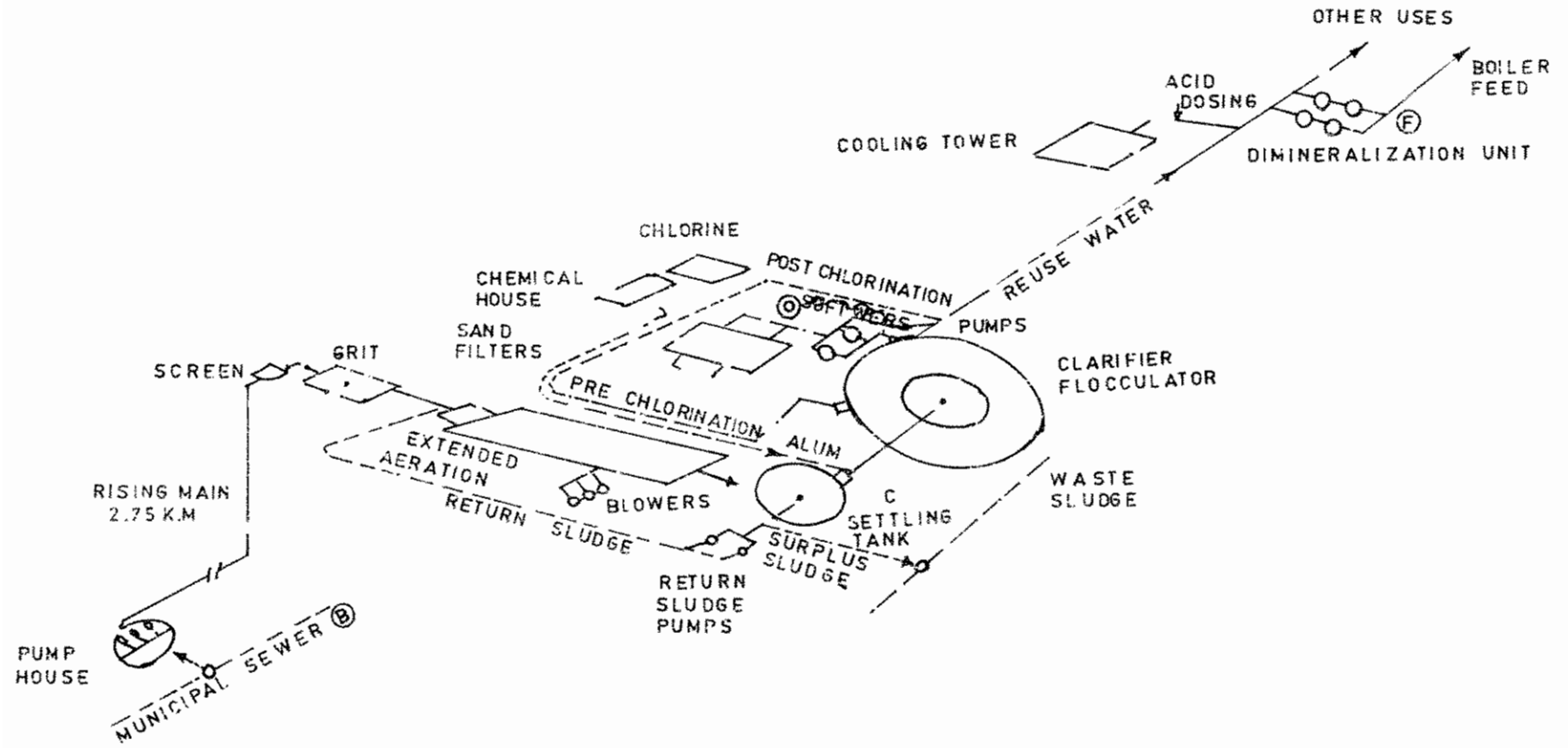

FIG.19.3: ILLUSTRATIVE FLOWSHEET FOR TREATMENT OF MUNICIPAL WASTE WATER FOR REUSE IN COOLING BOILER FEED AND OTHER USES

19.6 REUSE FOR AGRICULTURAL PURPOSES

For general agricultural uses of reclaimed water, the quality guidelines may be useful though it is always advisable to associate an experienced agronomist in deciding on actual water quality requirements, especially in case of large farms. If the water quality after secondary treatment does not meet agricultural use requirements, additional treatment would have to be provided.

Tertiary treatment is mainly needed for meeting coliform and helminth standards which are not met by conventional treatment processes. While coliforms are readily removable by chlorination, helminths are not. Helminth removal can be economically done in the case of relatively large farms by provision of 3-celled oxidation ponds (maturation ponds) of short detention time of 6-7 days only after the regular primary and secondary treatment units (Fig 19.4a). The land requirement of such ponds can generally be found within the relatively large irrigation command area.

For small orchards and farms and for lawns and gardens, helminth removal can be achieved in small land space by using pressure filters or open sand filters rather than oxidation ponds (Fig 19.4b). Chlorination is done for coliform removal. Filtration is also useful where drip irrigation systems are proposed to be used.

19.7 REUSE BY GROUND WATER RECHARGE

A certain amount of unintentional (incidental) ground water recharge occurs during regular land irrigation with fresh water or treated sewage. But intentional recharge at faster precolation rates in soils of required porosity and geological terrain has been limited in India by fresh waters only though treated sewage effluents can also be used.

The availability of suitable sandy, loamy, or gravelly soils with good infiltration characteristics is essential. A number of shallow recharge basins are provided in parallel. Each basin may be a long rectangle, a few hundred meters long dosed with wastewater (pre-treated as necessary) to a depth of about 20-30 cms once or more per day, and operated on an intermittent schedule of a few days wet followed by a few days dry.

Direct recharge systems in permeable soils used in some countries are of the high-rate type and application rates of 1000-3000 cu.m/ha/day have been used with pretreated sewage compared to regular land irrigation rates of only 100-300 cu.m/ha/day. Ground water recharges systems must be differentiated from "deep well" injection systems in which the aim is wastewater disposal to a deep aquifer of poor quality (e.g. brackish aquifer) with no possibility for consumptive use.

The physical, chemical and biological quality of the wastewater has to be kept compatible with the characteristics of the soil and the aquifer into which recharge occurs. Suspended solids, algae, precipitated substances, can affect infiltration rates over a period of time, and the quality of the reclaimed water. Hence some pre-treatment of wastewater before recharge is generally required.

The pollution of ground water by nitrates contained in sewage can be controlled by intermittent operation of the recharge basins. Experiments in USA have shown that a sequence of long inundation periods (14 days wet, 7 days dry) yielded about 90% removal of nitrogen whereas with short sequences (2 days wet, 3 days dry) the nitrogen in sewage was converted to nitrates in the percolated water. Longer wet periods with consequent anaerobicity encouraged denitrification. During dry periods, the soil gets aerated and aerobic degradation of organic matter held in the upper layers of the soil occurs.

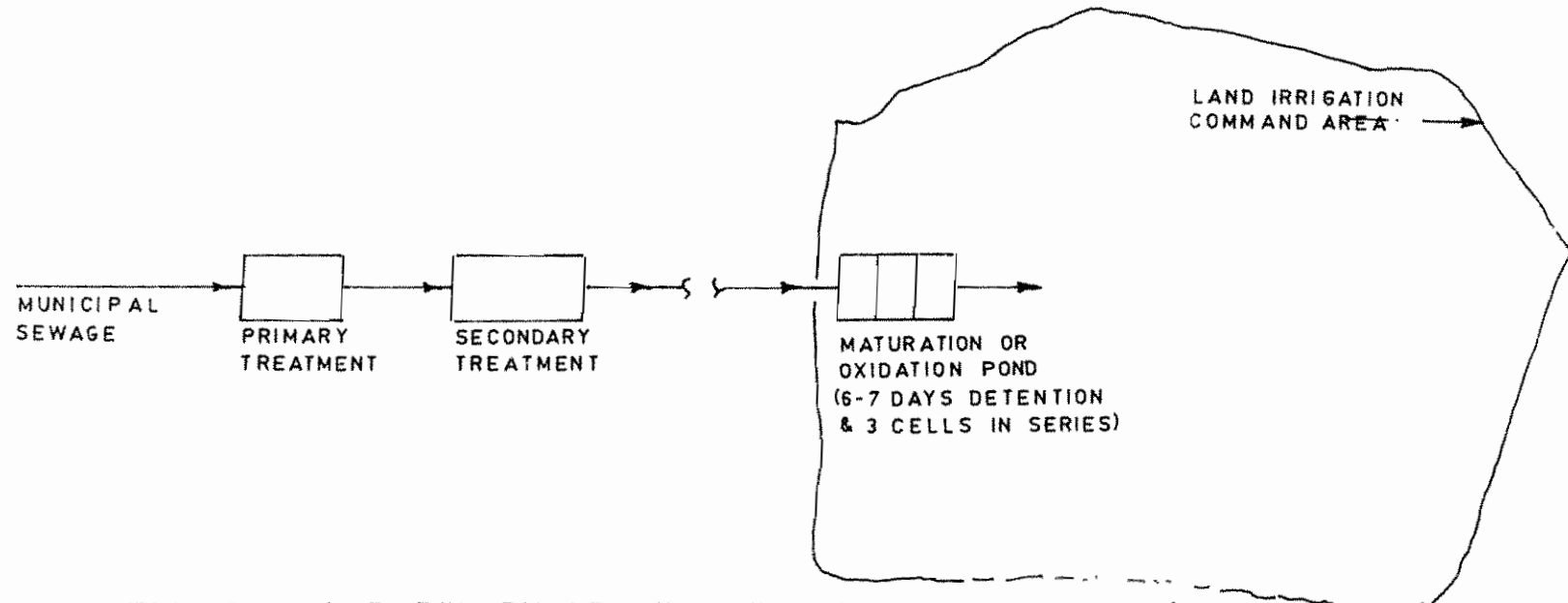

FIG. 19.4 a : TERTIARY TREATMENT FOR LAND IRRIGATION (LARGE SCALE)

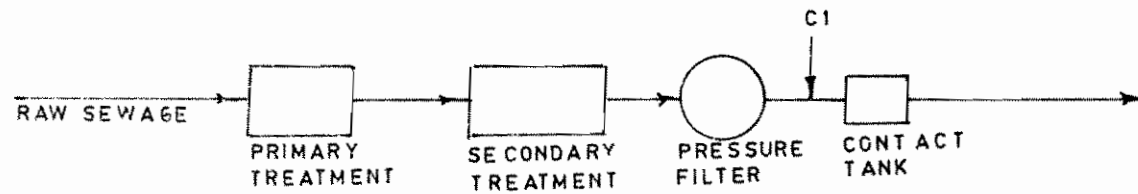

FIG. 19.4 b : TERTIARY TREATMENT FOR SMALL IRRIGATION SYSTEMS SERVING LAWNS, GARDENS, ORCHARDS, ETC.

Most soils are capable of efficiently removing phosphorus and micro organisms from the applied wastewater. Heavy metals are also removed well especially in alkaline soils

Table 19.7 gives the observed efficiency of Rapid Infiltration ponds. A remarkably high degree of removal of most constituents is achieved.

TABLE 19.7
EFFECTIVENESS OF LAND DISPOSAL TECHNIQUES

Item	Approximate Efficiency of Removal (%)
	Rapid Infiltration Ponds
BOD	99
Suspended Solids	99
N	80
P	90
Heavy Metals	95
Organic compounds	90
Viruses	99+
Bacteria	99+
Total Cations	0 - 75
Total Anions	0 - 50

Data on pre-treated sewage application rates on different types of soils, as well as the optimum wet period - dry period schedules based on Indian experience are not available.

The choice of ground water recharge system must take into account the fact that the treated wastewater so used reduces its availability downstream as a surface water resource. This also occurs when land irrigation is done, but irrigational use helps produce food crops whereas ground water recharge is of no special benefit unless someone downstream abstracts the ground water for reuse, or ground water recharge helps prevent saline water intrusion or recharge helps lift up the general ground water level in the downstream area. Thus, a scheme has to be drawn up on a macro-scale to be beneficial.

On a limited scale, wastewater can be treated and recharged into the ground through a basin or well, and abstracted from another well located just 50-100 m downstream so as to use the intervening soil matrix for further treatment of the wastewater to make it fit for reuse in certain industrial purposes.

EFFLUENT DISPOSAL AND UTILISATION

20.1 GENERAL

The effluent from sewage treatment plants may be discharged in receiving waters such as lakes, streams, rivers, estuaries, oceans or on land. The nature and degree of treatment given to the sewage is dependent upon the requirements imposed by the regulatory authorities. It is the large water portion along with small residual organics after treatment that has to be disposed of while the major portion of the organics is handled within the treatment plant itself. The water content of the sewage effluent along with the fertility value of the nutrients serves to make it useful for irrigation and pisciculture; the effluent is also put to low-grade industrial uses where water of high quality is not important or for artificial recharging of aquifers in areas of rapid depletion or underground water sources. Competing land uses, public health impact, energy requirement, aesthetics and biological effects decide the mode of disposal whether on land or in water. The problems encountered in the selection process are complex and demand a multidisciplinary approach.

20.2 DISPOSAL INTO WATER BODIES

Treated effluent conforming to prescribed standards may be disposed into a stream course or into sea or a stagnant body of water. The quality, quantity and use of the receiving water body into which the effluent is discharged decide the degree of treatment required for the sewage. Since the treated waste water may still have a high coliform density, disinfection or any other treatment methods may be considered for reducing the coliform density before disposal of water into the water body.

20.2.1 Disposal into River

Disposal of wastewater in a river causes organic, chemical and microbial pollution. Organic pollution not only depletes the oxygen content in the river resulting in fish kill but also leads to heavy algal growth downstream. The waste assimilating capacity of the river depends on its self-purification properties, the estimation of which is very important to protect and promote the various beneficial uses to which the river water is put to. The wastewater discharge into the river is to be regulated in such a manner that it does not exceed its waste assimilating capacity and the options in this respect include wastewater treatment, wastewater reduction, alternate waste disposal points and methods and increase of the quantity of the available dilution water, where possible.

20.2.2 Disposal into Estuaries

Estuaries behave quite differently with respect to pollution dispersion and they generally have less assimilative capacity when compared to rivers or streams. As in the case of the rivers DO is the most important parameter that governs the presence of fish and other aquatic forms of life in the estuary. The fate and distribution of pollution discharges to an estuary depend on the nature of the pollutant, the type of estuary, well mixed or stratified, location of discharge point, the relative volumes of fresh, saline and wastewater and the mixing characteristics.

20.2.3 Disposal into Ocean

The capacity of the sea to absorb wastewater is less compared to freshwater systems because of its low oxygen and high dissolved solids content, even though the water availability for dilution is high. Since the specific gravity of sea water is greater and temperature lower than that of wastewater, the lighter

and warmer wastewater will rise to the surface when discharged into the sea resulting in the spreading of the wastewater as a thin film or sleek. In view of the special characteristics of the marine eco system, the outfall should be carefully located taking into account sea currents, wind direction, wind velocity, tidal cycles etc. To prevent backing up and spreading of wastewater on the sea shore, it is desirable to dispose of wastewater only during low tides. To ensure effective mixing, the wastewater should be taken to a distance of about 1½ Km into the sea from the shoreline and discharged in deep sea at a point 3 to 5 m below water level. It should be properly supported by piers placed on firm rocky foundation to protect it from external forces, including corrosion and erosion and must be provided with flap gates to prevent tidal waters entering the outfall causing backflow.

20.2.4 Basic Information

The Basic information to be collected for planning effluent outfall works should consist of

- i) Studies on the quantity and the characteristics of the treated effluent including its toxicity
- ii) hydrographic surveys and examination of available hydraulic and hydrographic records including :
 - a) run off records and characteristics of flow both at and below the point of disposal during the lean flow periods in the case of streams
 - b) observations on currents and effects of winds and temperature stratification upon the dispersion of the sewage, in the case of lakes, and
 - c) tides, the effect of winds, salinity and temperature stratification upon the movement of the sewage, in the case of tidal estuaries.
- iii) Studies of possible locations for and forms of sewer outfall in its relation to hydrographic conditions particularly in the case of lakes and ocean outfall, and
- iv) Studies of the various uses of the water receiving the sewage effluent, giving due consideration to the protection of water supplies, safeguarding of the bathing and other recreational facilities, conservation and protection of useful aquatic life, the avoidance of unsightly or offensive conditions created by the sewage solids on or in the waters or along the shores, the prevention of sludge bank formation and of the resulting encroachment on water ways and prevention of pollution of water bodies.

When points of effluent discharge are well arranged and effluent quantities are limited, there is no serious threat to ground water quality. However, in many unsewered residential areas, particularly suburban developments, domestic wastes are disposed of through closely spaced individual sewage disposal units sometimes interspersed with water wells. Adequate precautions should be taken to ensure that the water sources are not contaminated by the improper location of cesspools, septic tanks and subsurface dispersion systems. Some of the synthetic detergents are not usually removed by passage through the soil mantle.

20.3 RECLAMATION OF TREATED EFFLUENT

Complete reclamation of sewage effluent is not generally adopted, this being only supplementary to other methods of disposal. Reclamation is restricted to meet the needs depending upon the availability and cost of fresh water, transportation and treatment costs and the water quality standards and its end uses like watering of lawns and grass lands, cooling, boiler-feed and process water; forming artificial lakes;

wetting of refuse for compaction and composting and raising agricultural crops. Some of these uses may need tertiary treatment as discussed in Chapter 19.

20.4 PISCICULTURE

If local conditions are suitable, partially purified sewage effluent may be used for fish culture without further dilution. Raw sewage cannot directly be used for fish culture as it does not contain sufficient dissolved oxygen for the survival and growth of fish. The waste stabilisation pond effluent and the percolated effluent from sewage farms have been successfully used in fish culture.

20.5 ARTIFICIAL RECHARGE OF AQUIFERS

Artificial recharge of ground water aquifers is one of the methods for combining effluent disposal with water reuse. Replenishment of ground water sources has been done on a practical scale. Treated effluent has been used to arrest salt water intrusion which may take place due to the lowering of ground water table by excessive pumping to meet large water demands. In the present day when conservation, reclamation and reuse of water are receiving increasing emphasis, sewage effluent constitutes a valuable source for recharging ground water.

20.6 DISPOSAL ON LAND

20.6.1 Sewage Farming

The nutrients in sewage like nitrogen, phosphorus and potassium along with the micronutrients as well as organic matter present in it could be advantageously employed for sewage farming to add to the fertility and improve the drainage characteristics of the soil, along with the irrigation potential of the water content. However, use of raw sewage or night soil or sullage is fraught with public health dangers. Even application of treated effluent to land has to be carried out with certain precautions as it is not completely free from this risk. A good sewage farm should be run on scientific lines with efficient supervision with the primary objective of disposal of sewage combined with its utilisation to the possible extent in a sanitary manner without polluting the soil, open water courses or artesian waters or contaminating crops raised on the sewage farm, or impairing the productivity of the soil. It should also provide for hygienic safety of the staff to protect them against the infection by pathogenic organisms and helminths.

Though sewage after primary treatment can be applied to the farms, the temptation of providing only primary treatment and eliminating secondary treatment merely on cost considerations should be resisted. Effluent from properly designed waste stabilisation ponds is also suitable for application on land. Under no conditions, application of raw sewage on sewage farms should be permitted.

A moderately permeable soil capable of infiltrating approximately 5 cm/day or more on an intermittent basis is preferable. In general most soils are suitable for farming, provided proper management practices are followed.

20.7 WATER QUALITY CONSIDERATIONS FOR IRRIGATION WATERS

The quality of water for irrigation is determined by the effects of its constituents both on the crop and the soil. The deleterious effects of the constituents of the irrigant on plant growth can result from (i) direct osmotic effects of salts in preventing water uptake by plants, (ii) direct chemical effects upon the metabolic reactions in the plants (toxic effect) and (iii) any indirect effect through changes in soil structure permeability and aeration.

The suitability of an irrigant is judged on the basis of soil properties, quality of irrigation water and salt tolerance behaviour of the crop grown in a particular climate. The water quality ratings along with the specific soil conditions recommended for the country are shown in Table 20.1.

These limits apply to the situations where the ground water table at no time of the year is within 1.5 m from the surface. The values have to be reduced by half if the water table comes up to the root zone. If the soils have impeded internal drainage either on account of presence of hard stratum, unusually high amounts of clay or other morphologic reasons, advisedly the limit of water quality should again be reduced to half. In cases where canal irrigation exists during the lean period, treated wastewater of higher electrical conductivity could be used.

20.7.1 Osmotic Effects

When water is applied for cultivation on land, some of it may run off as surface flow or be lost by direct surface evaporation, while the remainder infiltrates into the soil.

TABLE 20.1
WATER QUALITY RATINGS

Nature of Soil	Crop to be grown	Permissible limit of Electrical Conductivity of Water for safe irrigation (micro-mhos/cm)
Deep black soils and alluvial soils having a clay content more than 30%.	Semi-Tolerant	1500
Fairly to moderately well drained soils	Tolerant	2000
Heavy textured soils having a clay content of 20 - 30%	Semi-Tolerant	2000
Soils well drained internally and having good surface drainage system	Tolerant	4000
Medium textured soils having a clay content of 10 - 20%	Semi-Tolerant	4000
Soils very well drained internally and having good surface drainage system	Tolerant	6000
Light textured soils having a clay content of less than 10%	Semi-Tolerant	6000
Soils having excellent internal and surface drainage	Tolerant	8000

Of the infiltration water, a part be used consumptively, and part is held by the soil for subsequent evapotranspiration and the remaining surplus percolates or moves internally through the soil. The water retained in the soil is known as the 'soil solution' and tends to become more concentrated with dissolved constituents as plants take relatively purer water. An excessive concentration of salts in the soil solution prevents water uptake by plants. Table 20.1 shows permissible levels of electrical conductivity (EC) and hence total salts in water for safe irrigation in the four types of soils. It may be pointed out that good

drainage of the soils may be a more important factor for crop growth than the EC of the irrigant as leaching of soils results in maintaining a low level of salt in soil solution in the root zone.

20.7.2 Toxic Effects

Individual ions in irrigation water may have toxic effects on plant growth. Table 20.2 lists some of the known toxic elements and their permissible concentration in irrigation waters when continuously applied on all soils and also when used on fine texture soils for short terms. Many of these are also essential for plant growth.

The suggested values for major inorganic constituents in water applied to land are presented in Table 20.3.

Table 20.4 presents the suggested limits for salinity in irrigation waters.

TABLE 20.2
MAXIMUM PERMISSIBLE CONCENTRATION OF TOXIC ELEMENTS
IN IRRIGATION WATERS

Element		Maximum Permissible concentration (mg/l)	
		For water used continuously on all soils	For short term use of fine texture soils
Aluminium	Al	1.0	20.0
Arsenic	As	1.0	10.0
Beryllium	Be	0.50	1.0
Boron	B	0.75	2.0
Cadmium	Cd	0.005	0.05
Chromium	Cr	5.0	20.0
Cobalt	Co	0.2	10.0
Copper	Cu	0.2	5.0
Flourine	F	-	10.0
Lead	Pb	5.0	20.0
Lithium	Li	5.0	5.0
Manganese	Mn	2.0	20.0
Molybdenum	Mo	0.005	0.05
Nickel	Ni	0.5	2.0
Selenium	Se	0.05	2.0
Vanadium	V	10.0	10.0
Zinc	Zn	5.0	10.0

TABLE 20.3
SUGGESTED VALUES FOR MAJOR INORGANIC CONSTITUENTS
IN WATER APPLIED TO THE LAND

Problem and Related Constituent	Impact on the land *		
	No problem	Increasing Problem	Severe
Salinity			
Conductivity of Irrigation water millimhos/cm	< 0.75	0.75 - 3.00	> 3.00
Permeability			
Conductivity of Irrigation water millimhos/cm	< 0.50	< 0.50	< 0.20
SAR	< 6.00	6.00 - 9.00	> 9.00
Specific Ion Toxicity			
from root absorption			
Sodium (evaluated by SAR) me/l	< 3.00	3.00 - 9.00	> 9.00
Chloride, me/l	< 4.00	4.00 - 10.00	> 10.00
Chloride, mg/l	< 142.00	142.00 - 355.00	> 355.00
Boron, mg/l	< 0.50	0.50 - 2.00	2.00 - 10.00
From foliar absorption (sprinklers)			
Sodium, me/l	< 3.00	> 3.00	-
Sodium, mg/l	< 69.00	> 69.00	-
Chloride, me/l	< 3.00	> 3.00	-
Chloride, mg/l	< 106.00	> 106.00	-
Miscellaneous			
NO ₃ - N, NH ₄ - N mg/l for sensitive crops	< 5.00	5.00 - 30.00	> 30.00
HCO ₃ ⁻ , mg/l (only with overhead sprinklers)	< 1.50	1.50 - 8.50	> 8.50
HCO ₃ ⁻ , mg/l	< 90.00	90.00 - 520.00	> 520.00
pH	Normal range 6.5 - 8.4		

* Interpretations are based on possible effects of constituents on crops and/or soils. Suggested values are flexible and should be modified when warranted by local experience or special conditions of crop, soil and method of irrigation.

SAR : Sodium Absorption Ratio.

TABLE 20.4
SUGGESTED LIMITS FOR SALINITY IN IRRIGATION WATERS

Crop Response	Total dissolved solids mg/l	Electrical conductivity mhos/cm
No detrimental effects will usually be noticed.	500	0.75
Can have detrimental effects on sensitive crops.	500 - 1000	0.75 - 1.50
May have adverse effects on many crops.	1000 - 2000	1.50 - 3.00
Can be used for salt tolerant plants on permeable soils with careful management practices.	2000 - 5000	3.00 - 7.50

20.7.3 Impairment of Soil Quality

20.7.3.1 SODIUM HAZARD

In most normal soils, calcium and magnesium are the principal cations held by the soil in replaceable or exchangeable form. Sodium tends to replace calcium and magnesium when continuously applied through irrigation waters. An increase of exchangeable sodium in the soil causes deflocculation of soil particles and promotes compaction, thereby impairing soil porosity and the water and air relations of plants. The sodium hazard of irrigation water is commonly expressed either in terms of percent soluble sodium (PSS) or sodium absorption ratio (SAR) where

$$PSS = \frac{100 \times Na^+}{Na^+ + Ca^{++} + Mg^{++} + K^+}$$

or

$$\frac{100 \times Na^+}{(Total\ Cations)} \quad (21.1)$$

and

$$SAR = \frac{Na^+}{\left(\frac{Ca^{++} + Mg^{++}}{2}\right)^{\frac{1}{2}}} \quad (21.2)$$

and the cations are expressed as meq/l. Generally the sodium hazard of soil increases with the increase of PSS or SAR of irrigation water and exchangeable sodium percentage of the soil. The maximum permissible value of PSS in irrigation water is 60. Where waters with higher PSS values are used, gypsum should be added to the soil occasionally for soil amendment. SAR values greater than 9 may adversely affect the permeability of soils.

Hazardous effect of sodium is also increased if the water contains bicarbonate and carbonate ions in excess of the calcium and magnesium and there is a tendency for calcium and magnesium to precipitate as carbonates from the soil solution and thereby increasing the relative proportion of exchangeable sodium. Values of residual sodium carbonate (RSC)* less than 1.25 mg/l are considered safe and above 2.5 mg/l as unsuitable.

$$* RSC = (CO_3^{2-} + HCO_3^-) - (Ca^{2+} + Mg^{2+})$$

where all ion concentrations are expressed as meq/litre.

The effect of potassium on soil is similar to that of sodium but since the concentration of potassium is generally quite small in irrigation waters, it is often omitted from consideration.

20.7.3.2 ORGANIC SOLIDS

While stable organic matter improves porosity of soil, thereby facilitating aeration, an excessive application of unstable organic matter would lead to oxygen depletion in the soil. Depositing of sediments especially when they consist primarily of clays or colloidal material may cause crust formations which impede emergence of seedlings. In addition, these crusts reduce infiltration with the consequent reduction of irrigation efficiency and less leaching of saline soils.

20.7.4 Other Considerations

Soils are usually well buffered systems. The pH is not significantly affected by application of irrigation water. However, extreme values below 5.5 and above 9.0 will cause soil deterioration. Development of low pH values in soils promotes dissolution of elements such as iron, aluminium or manganese in concentrations large enough to be toxic to plant growth. Similarly, water having high pH values may contain high concentration of sodium, carbonates and bicarbonates, the effect of which have been discussed earlier.

Chlorides and sulphates are toxic to most crops in high concentrations. Ordinarily, the detrimental effects of salinity on crop growth become perceptible first.

Excessively high or low temperature in irrigation water may affect crop growth and yields. A desirable range of water temperature is from 12 to 30°C.

20.8 DESIGN AND MANAGEMENT OF SEWAGE FARMS

Optimum utilisation of sewage in agriculture means the complete and judicious use of its three main components, viz., water, plant nutrients and organic matter on the farms in such a way that (a) the pathogenic infection is neither spread among the farm workers nor among the consumer of sewage farm products, (b) the ground water is not contaminated, (c) there is maximum outturn per unit volume of sewage (d) there is no deterioration of the soil properties and (e) none of the three components is wasted.

20.8.1 Management of Water in Sewage Farming

The principle to be borne in mind in irrigation management is to irrigate only when it is required and only to the extent it is required by the crop. The water requirement depends on the soil type, the crop and the climate. The water requirement (cm) of main soil types to be wetted to a depth of 30 cms required by most of the crops is given in Table 20.5.

TABLE 20.5
WATER REQUIREMENTS (cm) TO WET DIFFERENT
SOILS TO A DEPTH OF 30 CM.

Type of Soil	Requirement (cm)
Sand	1.25
Sandy Loam	2.50
Loam	5.00
Clay Loam	6.25
Clay	7.50

Water requirement of crops vary with the duration of their growing season and the amount of growth in unit time. Details for some of the Indian crops which can be grown on sewage farms are given in Table 20.6.

TABLE 20.6
WATER REQUIREMENTS OF CROPS

	Crops	Growing Period (days)	Total Water requirements (cm)	Optimum pH range
1	Soyabean	110 - 120	37.50	6.0 - 8.5
2	Mustard	120 - 140	37.50 - 55.00	6.0 - 9.5
3	Sunflower (kharif)	100 - 110	37.50	6.0 - 8.5
4	Sunflower (rabi)	110 - 120	67.50	6.0 - 8.5
5	Barley	88	35.25	6.5 - 8.5
6	Cotton	202	105.50	5.0 - 6.0
7	Jowar	124	64.25	5.5 - 7.5
8	Maize	100	44.50	5.5 - 7.5
9	Linseed	88	31.75	5.0 - 6.5
10	Rice	98	104.25	5.0 - 6.0
11	Milking varieties of Sugarcane	365	237.50	6.0 - 8.0
12	Wheat	88	37.00	5.5 - 7.5

20.8.1.1 HYDRAULIC LOADING

The elements to be considered in determining hydraulic loading are the quantity of effluent to be applied, precipitation, evapotranspiration, percolation and run off. For irrigation systems, the amount of effluent applied plus precipitation should equal the evapotranspiration plus a amount of percolation. In most cases, surface runoff from fields irrigated with sewage effluent is not allowed or must be controlled. The water balance then will be

$$\text{Precipitation} + \text{Wastewater application} = \text{Evapotranspiration} + \text{percolation}$$

Seasonal variations in each of these values should be taken into account by evaluating the water balance for each month as well as the annual balance.

The irrigation requirement of any crop is not uniform throughout its growing period. It varies with the stage of growth. For example grain crops require maximum irrigation during the time of ear-head and grain formation. Sugarcane requires more frequent irrigation from about the sixth or the seventh month onwards. In case of fruit trees the irrigation has to be stopped during their resting period. If the irrigation is not given at critical growth stages of the crop, it results in lower yields.

Water requirement of crop at different stages of growth can be determined either directly (gravimetrically) or indirectly by use of Tensiometers or Irrimeters or Gypsum blocks. Normally, when there is about 50% depletion of available moisture in the soil, irrigation is recommended. The crop plants themselves show signs of moisture stress. One has to be always on the look out for such first symptoms to determine the need for irrigation. Some plants like sunflower also serve as good indicators of stress symptoms. Sunken screen pan evaporimeter could also be used for estimating use of water by crop plant and scheduling irrigation.

The extent of irrigation depends on the depth of irrigation to be given and volume of water required to wet the soil to the required depth. If tensiometers or Gypsum blocks are embedded at the required depths, they would indicate the stage when the soil at that depth is saturated. Nearly about 70 to 80% roots of most crops are found in the first 30 cm. of the soil. Some may go deeper to the next 30 cm. Normally, in irrigating medium type of soil it is wetted to about 30 cm. depth or a little more.

If the figures for water requirements for crop as mentioned in Table 20.6 are to be satisfied, much higher hydraulic loadings have to be applied since a portion of sewage after its passage through the soil is carried away by the sub-soil underdrainage system. The extent of desirable percolation rate depends upon the salinity of the irrigant. The applicable hydraulic loadings of settled sewage are therefore dependent upon the type of soil and the recommended rates are given in Table 20.7.

Sewage conforming to the norms should be applied to the soil by strip, basin or furrow irrigation. Wild flooding should not be adopted. Sprinkler irrigation could be used for adequately treated sewage.

The distribution channels should be properly graded to avoid ponding and silting. It is advisable that the main distributary is lined.

TABLE 20.7
RECOMMENDED HYDRAULIC LOADINGS

	Type of Soil	Hydraulic Loading (Cu.M/hectare/day)
i)	Sandy	200 - 250
ii)	Sandy Loam	150 - 200
iii)	Loam	100 - 150
iv)	Clay Loam	50 - 100
v)	Clayey	30 - 50

20.8.1.2 ORGANIC LOADING

11.0 to 28.0 Kg/ha/day of organic loading in terms of BOD₅ is needed to maintain a static organic matter content in the soil that helps to condition the soil by microorganisms without soil clogging. Higher loading rates can be managed depending on the type of system and the resting period. When primary effluent is used organic loading rates may exceed 22.0 Kg/ha/day without causing problems.

20.8.1.3 IRRIGATION INTERVAL

Resting periods for surface irrigation can be as long as 6 weeks but is usually between one and two weeks during which the soil bacteria break down organic matter and the water is allowed to drain from the top few centimeters, thus restoring aerobic condition in the soil. It depends upon the crops, the number of individual plots in the rotation cycle and management consideration.

20.8.2 Management of Soil

A well-planned program of crop growth and harvesting can help to maintain a soil receptive to effluent application. Crop uptake of nutrients followed by removal of the crop from the field increases the capacity of the land for removal of nutrients from the next effluent application.

It is necessary that the soil is given rest for about 3 to 4 months every alternate or third year preferably in summer months. This can be achieved if the farm is designed on the basis of water requirement in the winter season. After the harvest of the crop, the soil may be opened up by deep ploughing and cultivated appropriately to make it as porous and permeable as possible before the next crop is raised.

Maintenance of soil oxygen level is very important as it is required for root respiration and a number of biological processes in the soil. Refilling of oxygen in the pores in the surface layers of soil depends upon the reestablishment of contact of the soil with the atmosphere. This process can be accelerated by suitable cultural practices and by providing sufficient irrigation intervals. It is, therefore, desirable that an intercultural operation is followed as soon as the soil condition allows working after every irrigation. It should always be seen that the soils of sewage farm should have a surplus of oxygen than that normally required in the ordinary farm because the soil oxygen has to perform an additional job of satisfying the BOD of sewage. The intercultural operation following every one or two irrigations is all the more necessary in the case of clayey soil. In the areas where rainfall is low, it is desirable to flood the soils with irrigant at least once a year to leach down the salts accumulated in the soil. If the soil salinity and alkalinity pose

a serious problem, amendment of soil with the required quantity of gypsum should be carried out. Subsoil drainage is very important. Poor drainage should be improved by installing underground drains.

Sewage farm fields must be laid out in accordance with the natural slope of the terrain to eliminate the irregularities of distribution.

On sewage farms, no sewage should be allowed to flow beyond the farm boundaries. With this in view, protection banks are arranged along the lowest lying boundaries of each crop rotation field.

20.8.3 Utilisation of Plant Nutrients

Sewage contains 26-70 mg/l of nitrogen (N), 9-30 mg/l of Phosphate (P_2O_5) and 12-40 mg/l or even more of potash (K_2O). The recommended dosages for N, P and K for majority of field crops are in the ratio of 5:3:2 or 3 respectively. The figures for N, P, and K contents of sewage on the other hand show that sewage is relatively poor in phosphates. Excess potash is not of significance but a relative excess of nitrogen affects crop growth and development. Crops receiving excessive dosage of nitrogen show superfluous vegetative growth and decrease in grain or fruit yield. The phosphate deficit of sewage, therefore, should be made good by supplementing with phosphate fertilisers, the extent of phosphate fortification depending upon the nature of crop and its phosphate requirements. As the availability of phosphate is low in the irrigant it would be desirable to apply the required quantity of phosphatic fertiliser at the time or even (about a fortnight) before the sowing or planting of the crop.

Even when sewage nutrients are balanced by fortification, irrigation with such sewage may supply excessive amount of nutrients resulting in waste or unbalanced growth of plants with adverse effects on yields. It may therefore be necessary to dilute the sewage. Dillution also helps in reducing the concentration of dissolved salts and decomposable organic matter in the sewage thus decreasing hazards to the fertility of the soil. It is desirable to limit the BOD and total suspended solids of sewage to be disposed on land for irrigation, as per relevant standards.

20.8.4 Land requirements

The field-area requirement for farming based on the liquid loading rate is calculated by

$$A = [3.65 Q / L]$$

Where

- A = Field-area in hectares
 Q = Flow rate in Cu.m./day
 L = Annual liquid loading, cm/year

For loading of constituents such as Nitrogen

$$A = [0.365 CQ / L_c]$$

Where

- C = Concentration of the constituents, mg/l.
 L_c = Loading rate of the constituent, kg/ha/year.

20.9 ALTERNATIVE ARRANGEMENTS DURING NON-IRRIGATING PERIODS

During rainy and non-irrigating seasons, sewage farm may not need any water for irrigation. Even during irrigating season, the water requirement fluctuates significantly. Hence satisfactory alternative arrangements have to be made for the disposal of sewage on such occasions either by storing the excess wastewater or discharging it elsewhere without creating environmental hazards. The following alternatives are generally considered :

1. Provision of holding lagoons for off-season storage. They enable irrigation of a fixed area of land to varying rates of crop demand. They may also serve as treatment units such as aerated or stabilisation lagoons, provided the minimum volume required for treatment is provided beyond the flow-balancing requirement
2. Provision of additional land where wastewater is not required on the main plot of land
3. Discharge of surplus wastewater to river or into sea with or without additional treatment. Combining surface discharge facilities with irrigation system is quite common and often quite compatible
4. Resorting to artificial recharge in combination with an irrigation system where feasible.

20.10 PROTECTION AGAINST HEALTH HAZARDS

Sewage farms should not normally be located within 1 Km of sources of centralised water supply, or mineral springs; in the vicinity where waterbearing layers prevail; or on areas with ground water levels less than 2 m below the surface. Measures should be taken to prevent pollution of artesian water. Sewage farms must be separated from residential areas by at least 300 m.

The Public Health aspects of sewage farming should be considered from the view points of exposure of farm workers to sewage and that of the consumers to the farm products.

Evidence is on the increase to show that labourers working on the sewage farms suffer from a number of ailments directly attributed to handling of sewage. In view of this it is desirable to disinfect sewage and where feasible mechanise sewage farm operation.

Sewage or wastewater of individual enterprises engaged in the processing of raw material of animal origin or hospitals, biofactories and slaughter houses should in addition be disinfected before they are taken to the sewage farms.

Agricultural utilisation of sewage containing radio active substances are carried out in accordance with special instructions.

The staff of sewage farms must be well educated in the sanitary rules on the utilisation of sewage for irrigation as well as with personal hygiene.

All persons working in sewage farms must undergo preventive vaccination against enteric infections and annual medical examination for helminthoses and provided treatment if necessary.

Sewage farms should be provided with adequate space for canteens with proper sanitation, wash-stands and lockers for irrigation implements and protective clothing; besides, safe drinking water must be provided for the farm workers and for population residing within the effective range of the sewage farms.

All the farm worker should be provided with gum boots and rubber gloves which must compulsorily be worn while at work. They should be forced to observe personal hygiene such as washing after work as well as washing before taking food. The use of antiseptics in the water used for washing should be emphasized. The farm worker should be examined medically at regular intervals and necessary curative measures enforced.

Cultivation of crops which are eaten raw should be banned. Cultivation of paddy in bunded fields is likely to give rise to sanitation problems and hence is undesirable. Growing of nonedible commercial crops like cotton, jute, fodder, milling varieties of sugarcane and tobacco would be suitable. Cultivation of grasses and fodder legumes, medicinal and essential oil yielding plants like menthal and citronella may be allowed. Cultivation of cereals, pulses, potatoes and other crops which are cooked before consumption may be permitted, if sewage is treated and care is taken in handling the harvests to ensure that they are not contaminated. Cultivation of crop exclusively under seed multiplication programmes would be advantageous as these are not consumed. As an additional safeguard, sewage irrigation should be discontinued at least two months in advance of harvesting for fruits and berries, one month for all kinds of vegetables and a fortnight for all other crops. Direct grazing on sewage farms should be prohibited.

20.11 STANDARDS

It is necessary to adhere to the standards laid down by the Pollution Control Boards/Environmental Protection Act with regard to the quality of the sewage to be discharged into a body of water, inland or marine, or on land for farming purposes or into underground for purposes of recharge. Wherever, these provisions do not exist, the standards laid down by the Bureau of Indian Standards may be adhered to.

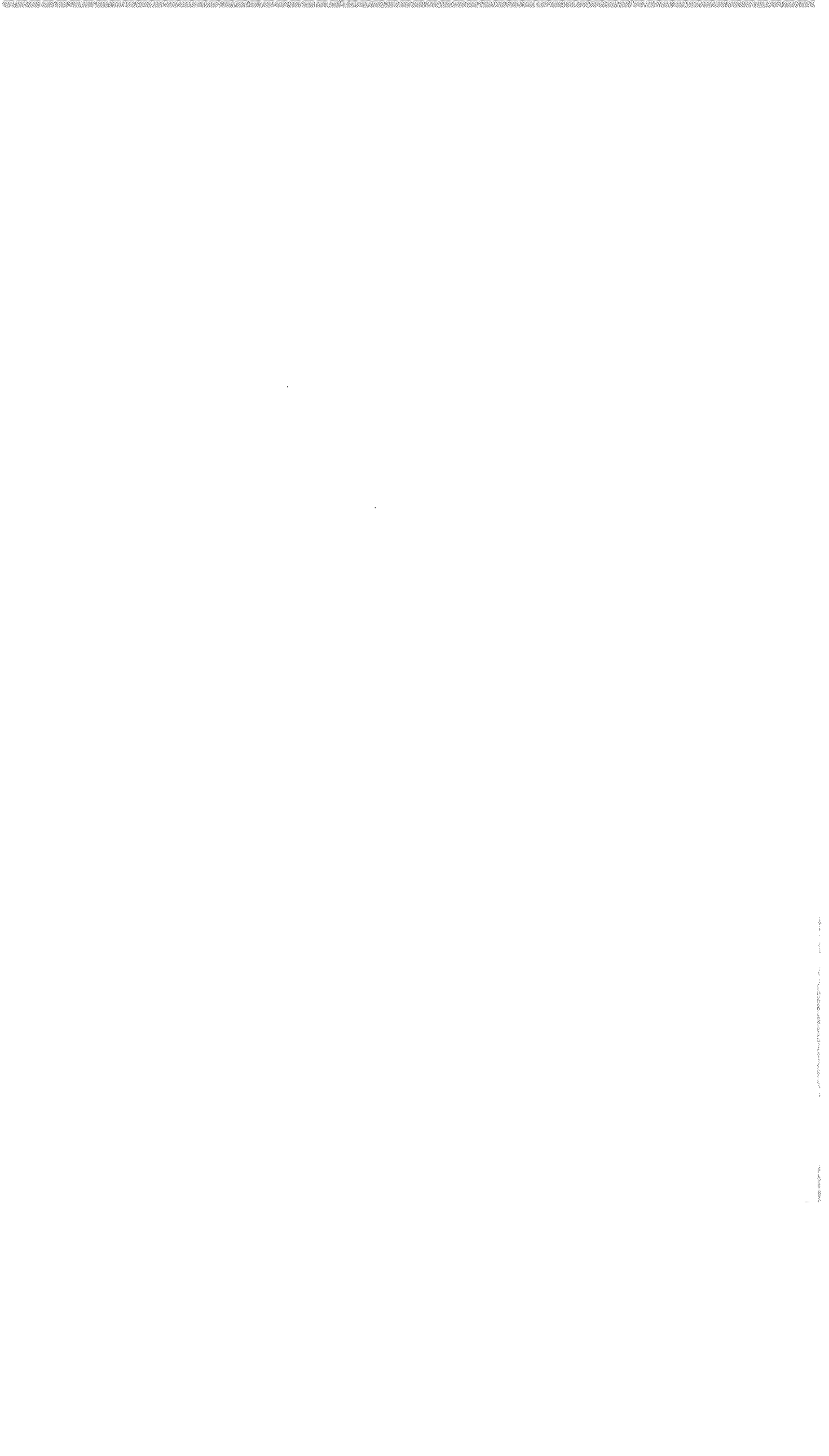

CHAPTER 21

ON-SITE SANITATION

21.1 BACKGROUND

The conventional off-site excreta disposal method - water borne sewerage system followed by a sewage treatment and disposal plant, is an expensive option and not affordable by low income communities and by small communities in rural areas. This resulted in the development of several alternative low cost on-site disposal methods, with almost the same health benefits. However, over a period of time most of these options have been discarded, mostly due to various operational reasons and only two options - Septic tanks and Twin pit Pour Flush latrines are being widely used. Therefore in this chapter, while the septic tank and twin pit pour flush latrines are discussed in detail, only an overview of other options is given.

21.2 SEPTIC TANK

A septic tank is a combined sedimentation and digestion tank where the sewage is held for one to two days. During this period, the suspended solids settle down to the bottom. This is accompanied by anaerobic digestion of settled solids (sludge) and liquid, resulting in reasonable reduction in the volume of sludge, reduction in biodegradable organic matter and release of gases like carbon dioxide, methane and hydrogen sulphide. The effluent although clarified to a large extent, will still contain appreciable amount of dissolved and suspended putrescible organic solids and pathogens. Therefore the septic tank effluent disposal merits careful consideration. Because of the unsatisfactory quality of the effluent and also the difficulty in providing a proper effluent disposal system, septic tanks are recommended only for individual homes and small communities and institutions whose contributory population does not exceed 300. For larger communities, septic tanks may be adopted with appropriate effluent treatment and disposal facilities.

21.2.1 Design

Several experiments and performance evaluation studies, have established that only about 30% of the settled solids are anaerobically digested in a septic tank. In case of frequent desludging, which is necessary for satisfactory effluent quality, still lower digestion rates have been reported. All these studies have proved that when the septic tank is not desludged for a longer period i.e., more than the design period, substantial portion of solids escape with the effluent. Therefore for the septic tank to be an efficient suspended solids remover, it should be of sufficient capacity with proper inlet and outlet arrangements. It should be designed in such a way that the sludge can settle at the bottom and scum accumulates at the surface, while enough space is left in between, for the sewage to flow through without dislocating either the scum or the settled sludge. Normally sufficient capacity is provided to the extent that the accumulated sludge and scum occupy only half or maximum two-thirds the tank capacity, at the end of the design storage period.

Experience has shown that in order to provide sufficiently quiescent conditions for effective sedimentation of the suspended solids, the minimum liquid retention time should be 24 hours. Therefore, considering the volume required for sludge and scum accumulation, the septic tank may be designed for 1 to 2 days of wastewater retention.

The septic tanks are normally rectangular in shape and can either be a single tank or a double tank. In case of double tank, the effluent solids concentration is considerably lower and the first compartment is usually twice the size of the second. The liquid depth is 1-2 m and the length to breadth

ratio is 2-3 to 1. Recommended sizes of septic tanks for individual households (upto 20 users) and for housing colonies (upto 300 users) are given below in tables 21.1. and 21.2 respectively :

TABLE 21.1
RECOMMENDED SIZES OF SEPTIC TANK UPTO 20 USERS

No. of Users	Length (m)	Breadth (m)	Liquid depth ((cleaning interval of)	
			2 years	3 years
5	1.5	0.75	1.0	1.05
10	2.0	0.90	1.0	1.40
15	2.0	0.90	1.3	2.00
20	2.3	1.10	1.3	1.80

Note 1 : The capacities are recommended on the assumption that discharge from only WC will be treated in the septic tank.

Note 2 : A provision of 300 mm should be made for free board.

Note 3 : The sizes of septic tank are based on certain assumption on peak discharges, as estimated in IS : 2470 (part 1) - 1985 and while choosing the size of septic tank exact calculations shall be made.

TABLE 21.2
RECOMMENDED SIZES OF SEPTIC TANK FOR RESIDENTIAL COLONIES

No.of Users	Length (m)	Breadth (m)	Liquid depth ((cleaning interval of)	
			2 years	3 years
50	5.0	2.00	1.0	1.24
100	7.5	2.65	1.0	1.24
150	10.0	3.00	1.0	1.24
200	12.0	3.30	1.0	1.24
300	15.0	4.00	1.0	1.24

Note 1 : A provision of 300 mm should be made for free board.

Note 2 : The sizes of septic tank are based on certain assumptions on peak discharges, as estimated in IS : 2470 (Part 1)-1985 and while choosing the size of septic tank exact calculations shall be made.

Note 3 : For population over 100, the tank may be divided into independent parallel chambers of maintenance and cleaning.

21.2.2 Construction Details

The inlet and outlet should not be located at such levels where the sludge or scum is formed as otherwise, the force of water entering or leaving the tank will unduly disturb the sludge or scum. Further, to avoid short circuiting, the inlet and outlet should be located as far away as possible from each other and at different levels. Baffles are generally provided at both inlet and outlet and should dip 25 to 30 cm into and project 15 cm above the liquid. The baffles should be placed at a distance of one fifth of the tank length from the mouth of the straight inlet pipe. The invert of the outlet pipe should be placed at a level 5 to 7 cm below the invert level of inlet pipe. Baffled inlet will distribute the flow more evenly along the width of the tank and similarly a baffled outlet pipe will serve better than a tee-pipe.

For larger capacities, a two-compartment tank constructed with the partition wall at a distance of about two-thirds the length from the inlet gives a better performance than a single compartment tank. The two compartments should be interconnected about the sludge storage level by means of pipes or square openings of dia or side length respectively of not less than 75 mm.

Every septic tank should be provided with ventilation pipes, the top being covered with a suitable mosquito proof wire mesh. The height of the pipe should extend at least 2 m above the top of the highest building within a radius of 20 m.

Septic tanks may either be constructed in brick work, stone masonry or concrete cast in situ or pre-cast materials. Pre-cast household tank made of materials such as asbestos cement could also be used, provided they are watertight and possess adequate strength in handling and installing and bear the static earth and superimposed loads.

All septic tanks shall be provided with watertight covers of adequate strength. Access manholes of adequate size shall also be provided for purposes of inspection and desludging of tanks.

The floor of the tank should be of cement concrete and sloped towards the sludge outlet. Both the floor and side wall shall be plastered with cement mortar to render the surfaces smooth and to make them water tight. A typical two compartment septic tank is shown in Figure 21.1.

21.2.3 Sludge withdrawal and Disposal

When sludge is drawn off from the bottom of the tank, at first the small quantity of sludge in the immediate vicinity of the outlet or suction pipe is withdrawn. This is followed by drawing off sewage, because the sludge, being only slightly heavier but much more viscous than the sewage, lies away from the point of outlet and the scum remains floating on the surface. With continued draw-off more sewage is removed, until finally only sludge and scum remain in the tank. These come off last, and then only if there is sufficient slope on the floor of the tank, force them to gravitate to the outlet. This is the reason for the slow bleeding-off of sludge from steep bottomed pyramidal sedimentation tanks and for desludging the septic by complete emptying. If septic tanks are desludged by partial removal only of the contents, they become more and more filled with sludge and scum, and the quality of the effluent deteriorates soon. For some reasons, desludging of septic tanks under hydrostatic head by means of a sludge pipe -collecting of sludge from the lowest point in the tank and discharging at a higher level, -should be discouraged. As far as particable manual handling of sludge should be avoided. If possible particularly in case of densely populated large cities, mechanical vaccum tankers should be used by the municipal authorities to empty the septic tanks. Alternately, where space is not a constraint, a sludge pipe -with a delivery valve to draw the sludge as and when required, -be installed at the bottom of the tank to empty its contents into a sump, for subsequent disposal on land or sent for further treatment. Spreading of sludge on the ground in the vicinity should not be allowed. Portable pumps may also be used for desludging in which case there will be no need for sludge pipe or sludge sump.

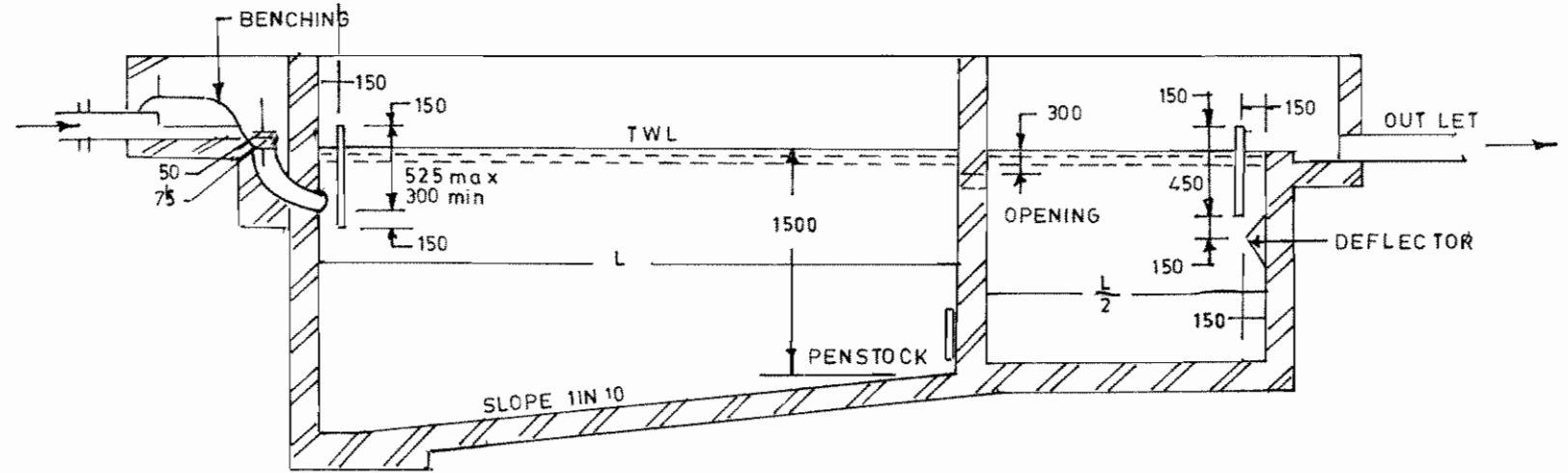
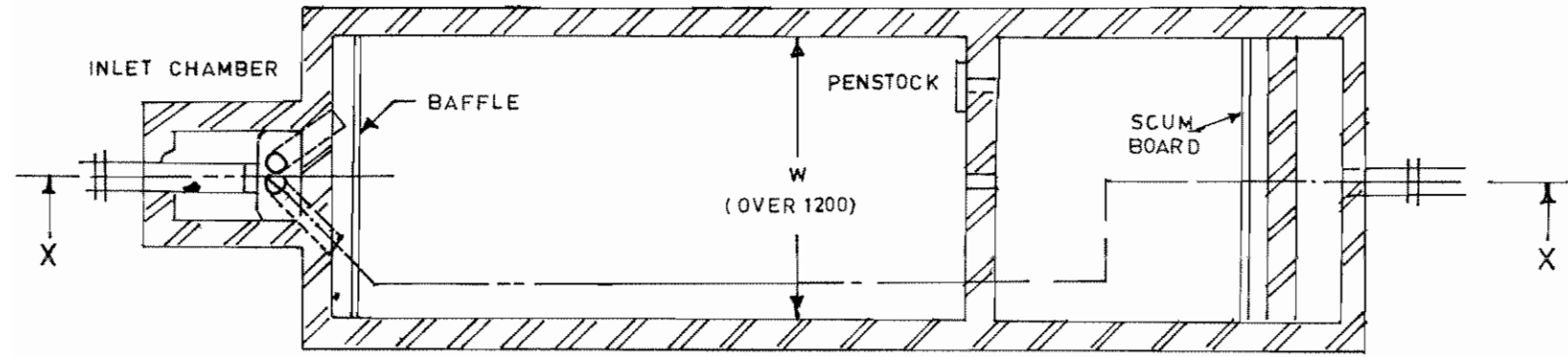

SECTION XX

ALL DIMENSIONS IN mm

FIG.21.1 : TYPICAL SKETCH OF TWO COMPARTMENT SEPTIC TANK FOR POPULATIONS OVER 50 (IS : 2470 (PART 1)-1985)

Yearly desludging of septic tank is desirable. But if it is not feasible or economical and if there is difficulty to find labour for desludging, small domestic tanks should be cleaned at least once in 1 to 2 years, provided the tank is not overloaded due to use by more than the number for which it is designed.

21.2.4 Secondary Treatment and Disposal of Effluent

The septic tank effluent will be malodorous, containing sizable portion of dissolved organic content and pathogenic organisms and hence need to be treated before its final, safe disposal. Depending upon the situation-the size, treatment objective, resources available etc., -the extent and type of secondary treatment facility can vary from the most conventional land disposal methods like soak pits or dispersion trenches to additional secondary biological treatment systems.

Normally the land disposal methods, are designed to achieve subsurface percolation or seepage into the soil. Satisfactory disposal therefore depends, to a great extent, on porosity and percolation characteristics of the soil. In addition, other factors, such as level of subsoil water table, the climatic conditions, presence of vegetation, aeration of soil and concentration of suspended solids in the effluent also influence the application of these methods. Soak pits or dispersion trenches can be adopted in all porous soils where soak percolation rate, as discussed in Appendix 21.1, is below 25 minutes per cm and the depth of water table is 2 m or more from the ground level. Dispersion trenches should be preferred in soils with percolation rates between 12 and 25 minutes if adequate land is available. In areas with higher water table, dispersion trenches should be located partly or fully above ground level, in a mound.

The subsoil dispersion system shall be at least 20 m away from any source of drinking water. It should also be as far as possible from the nearest dwellings but not close than 7 m to avoid any corrosive effect due to tank gases vented into atmosphere. Subsoil dispersion system is not recommended in limestone or crevice rock formations where they may be solution cavities which may convey the pollution to long distances and pollute water resources. In impervious soils such as dense clays and rocks, where percolation rate exceeds 25 minutes, adoption of upflow or reverse filters, trickling filters, subsurface sand filters or open sand filters followed by chlorination should be considered, particularly for larger installations.

In the absence of information relating to ground water or subsoil, subsurface explorations are necessary. Percolation tests as described in Appendix 21.2 determine the acceptability of the site and serve as the basis of design for liquid absorption. The total subsurface soil area required for soak pits or dispersion trenches is given by the empirical relation

$$Q = 130 \sqrt{t} \quad (21-1)$$

Where

- Q = maximum rate of effluent application in lpd/m² of leaching surface, and
t = Standard percolation rate for the soil in minutes.

In calculating the effective leaching area required, only area of trench bottom in case of dispersion trenches and effective side wall area below the inlet level for soak pits should taken into account.

21.2.4.1 SOAK PITS

Soak pits or seepage pits are cheap to construct and are extensively used. They need no media when lined or filled with rubble or brick bats. The pits may be of any regular shape, circular or square being more common. When water table is sufficiently below ground level, soak pits should be preferred only when land is limited or when a porous layer underlies an impervious layer at the top, which permits easier vertical downward flow than horizontal spread out as in the case of dispersion trenches. Minimum

horizontal dimension of soak pit should be 1 m, the depth below the invert level or inlet pipe being at 1 m. The pit should be covered and the top raised above the adjacent ground to prevent damage by flooding.

21.2.4.2 DISPERSION TRENCHES

Dispersion trenches consist of relatively narrow and shallow trenches about 0.5 to 1 m deep and 0.3 to 1 m wide excavated to a slight gradient of about 0.25%. Open joined earthenware or concrete pipes of 80 to 100 mm size are laid in the trenches over a bed of 15 to 25 cm of washed gravel or crushed stone. The top of pipes shall be covered by coarse gravel and crushed stone to a minimum depth of 15 cm and the balance depth of trench filled with excavated earth and finished with a mound above the ground level to prevent direct flooding of trench during rains. The effluent from the septic tank is led into a small distribution box from which several such trenches could radiate out. The total length of trench required shall be calculated from the Eq.(21.1) and the number of trenches worked out on the basis of a maximum length of 30 m for each trench and spaced not closer than 2 m apart. Parallel distribution should be such that a distribution box should be provided for 3 to 4 trenches.

21.2.4.3 UP-FLOW ANAEROBIC FILTER

The up-flow filter can be successfully used for secondary treatment of septic tank effluent in areas where dense soil conditions, high water table and limited availability of land preclude soil absorption or the leaching system for effluent disposal. It is a submerged filter with stone media and the septic tank effluent is introduced from the bottom. The microbial growth is retained on the stone media making possible higher loading rates and efficient digestion. The capacity of the unit is 0.04 to 0.05 m³ per capita or 1/3 to 1/2 the liquid capacity of the septic tank it serves. BOD removals of 70% can be expected. The effluent is clear and free from odor. This unit has several advantages viz. (a) a high degree of stabilization; (b) little sludge production; (c) low capital and operating cost; and (d) low loss of head in the filter (10 to 15 cms) in normal operation. The up-flow anaerobic filter can either be a separate unit or constructed as an extended part of septic tanks.

21.3 POUR FLUSH WATER SEAL LATRINES

In a conventional water flush latrine, the excreta is normally flushed with 10-14 litres of water from a cistern. In a pour flush latrine, as the name suggests, the excreta is hand flushed by pouring about 1.5 to 2.0 litres of water. These pour-flush leaching pit latrines were first developed in India in mid forties with a single leach pit and a squatting pan placed over it. When the pit in use gets filled up another pit is dug and the squatting slab is removed and placed over the new pit. The first pit is covered with earth and the excreta is allowed to digest. After one or two years, the digested excreta is used as a manure.

In late fifties, a modified design off-set system was developed. In this system the leach pit is kept away from the seat instead of placing it underneath the pan. In a single pit system, desludging has to be done almost immediately after the pit has been filled up to enable its re-use; this involves handling of fresh and undigested excreta containing pathogens - a health hazard. Single leach pit is appropriate only if it is desludged mechanically by a vacuum tanker. To overcome this short-coming, the Twin-pit design was introduced -when one pit is full, the excreta is diverted to the second pit. The filled up pit can be conveniently emptied after 1 1/2 to 2 years, when most of the pathogens die off. The sludge can safely be used as manure. Thus the two pits can be used alternately and perpetually.

With simple care, pour-flush water-seal latrine is a very satisfactory and hygienic sanitation system and hence it can be located inside the house since the water-seal prevents odour and insect nuisance.

21.3.1 Design and Materials

21.3.1.1 SQUATTING PAN, TRAP, FOOTRESTS AND CONNECTING DRAIN

The squatting pan is of special design with steep bottom slope 25 - 28° and a trap having 20 mm water seal set on a cement concrete floor. The hydraulic design of the pan is such that the human excreta can be flushed by pouring only 1½ to 2 liters of water. The squatting pan and trap design details are shown in Figure 21.2.

The squatting pan can be of ceramic or glass fibre reinforced plastic (GRP), High Density Polyethylene (HDPE) or Poly Vinyl Chloride (PVC), Poly propylene (PP), Cement mosaic or even concrete. The squatting pan is connected to the leaching pit through a trap and a pipe or covered drain.

The design and material details for latrine units squatting pan, trap, footrest and the connecting drain are summarized below in Table 21.3.

TABLE 21.3
MATERIAL AND OTHER DETAILS FOR LATRINE UNITS

Sl. No.	Squatting Pan	Trap	Footrests	Connecting Drain
1.	Horizontal length of pan should be at least 425mm and longitudinal bottom slope 25 - 28°	It should be 70 to 75 mm with 20 mm water seal	It should be 250 x 125 mm with 15 to 20 mm height	May be non pressure pipes of AC or PVC minimum 75 mm dia
2.	Material : Ceramic, FRP, PP, HDPE, PVC, Cement mosaic or Cement concrete	Fibre Glass, Ceramic, HDPE or CC traps	Ceramic or concrete with mosaic finish brick or stone	Bricks or stone semi circular bottom
3.	Should conform to IS:2556 (Pt.III) 1985, IS-11246, 1985 GRP Sq.Pan	Should conform to IS:2556 (Pt. XIII), 1973	Should conform to IS:2556, (Pt. X), 1974	Slope should be 1 in 5 to 1 in 15 as per the site conditions
4.	Ceramic, FRP, PP are smooth and require less water for flushing. FRP cheaper, lighter and easier to transport than the other			The inlet pipe should project 100 mm in to the leach pit A junction chamber of 250 x 250 mm should be provided in case of pipe.

21.3.1.2 SUPER STRUCTURE

A minimum latrine size of 75 cm x 90 cm is recommended. However, it is desirable to provide more spacious latrine of 80 cm x 100 cm size if cost is not a major consideration. The super structure of latrine cubicle could be brick or stone in mud or cement mortar. The low cost unit could be constructed of bamboo matting with mud plaster outside and inside with thatched or tiled roof.

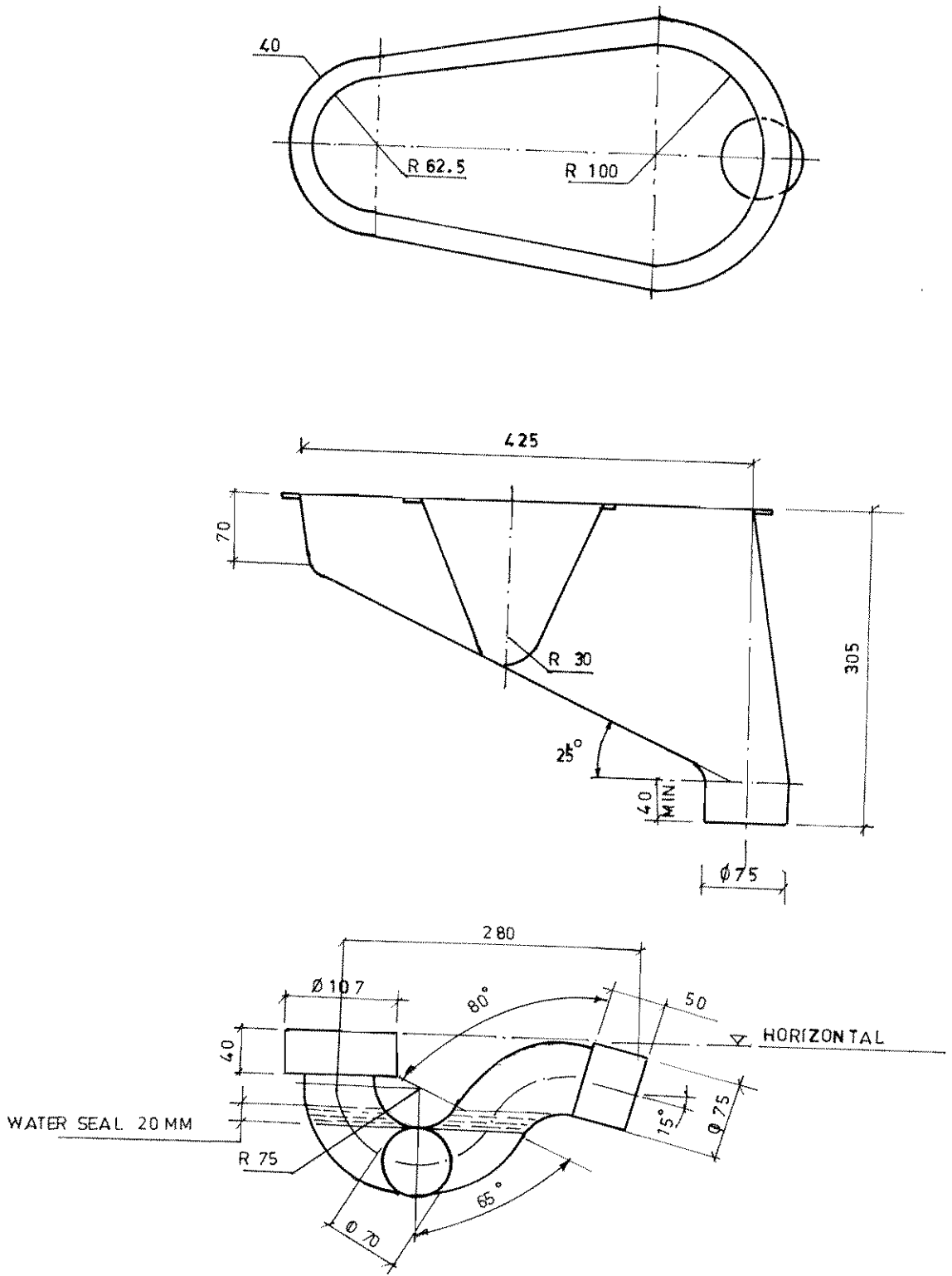

FIG.21.2 : SQUATTING PAN AND TRAP

21.3.1.3 LEACH PITS

Leach pits serve a dual function of (a) storage and digestion of excreted solids and (b) infiltration of the waste liquids. Leach pits, are therefore, to be designed on the basis of the following parameters :

- a) Solids accumulation rate
- b) Long term infiltration rate of the liquid fraction across the pit soil interface
- c) Hydraulic loading on the pit
- d) Minimum period required for effective pathogen destruction
- e) Optimal pit emptying frequency.

The above parameters are discussed below :

a) Solids Accumulation Rate

The sludge accumulation rate is a function of a wide range of variables including water table level, pit age, water and excreta loading rates, microbial conditions in the pit, temperature and local soil conditions and the type of material used for anal cleansing.

The leach pit is classified as wet or dry depending on whether the ground water table is above the bottom of pit or below. In dry pits, the pit volume needed is calculated on the basis of solids accumulation rate. But in wet pits though the sludge accumulation rate is lower - the sludge digestion rate is high in the presence of water, yet volume of pit has to be increased to prevent flooding due to surcharge of pits. The sludge accumulation rates given below may be used to calculate the pit volume.

**TABLE 21.4
VOLUME OF LEACH PITS**

Material used for anal cleansing	Effective Volume in m ³ per Capita per Year *		
	Pit under dry conditions	Pit under Wet conditions	
		with successive desludging intervals	
		2 years	3 years
Water	0.04	0.095	0.067
Soft Paper	0.053	0.114	0.080

* Effective volume is the volume of the pit below invert level of pipe or drain.

b) Long Term Infiltration Rate

On account of clogging of soil pores around the leach pits, the long term infiltration capacity (after clogging) of the soil is always less than the natural percolative capacity. The recommended design values of the long term infiltrative capacity can be derived for typical soil conditions as given in Table No.21.5.

TABLE 21.5
LONG TERM INFILTRATION RATES OF DIFFERENT TYPES OF SOILS

Sl. No.	Soil Type	Long Term Infiltrative Loading Rate (l/m ² per day)
1.	Sand	50
2.	Sandy Loam, Loams	30
3.	Porous silty loams, Porous silty Silty clay loams	20
4.	Compact silty loams, Compact silty clay loams, clay	10

c) **Hydraulic Loading**

The hydraulic loading rate is the total volume of liquids entering the leach pit and is expressed in liters per day although it is often more convenient to consider per capita loadings (liters per capita per day). For computing the pit hydraulic loading, wastewater contribution of 9.5 liters per day per person, including water used for ablutions and flushing, urine, excreta etc. can be taken as the basis. The outer surface area (perimeter) of the pit from pit bottom to invert level of pipe or drain is to be considered for infiltration. The pit bottom is not taken into account as it gets clogged in course of time. The infiltration area required is the total flow in the pit per day divided by the long term infiltrative rate of the soil where pits will be located. The infiltrative area of leach pits, sized on the basis of sludge accumulation rate should conform to the computed infiltrative area.

d) **Pathogen Destruction**

After a period of one and half years, almost all pathogens viruses, bacteria, protozoa and helminths - eventually die off in the leach pit or in the surrounding soil, with the exception of *Ascaris Lumbricoides* (the large human round-worm) - particularly if the leach pit is wet. After about one or one-and-half-years of storage in the pit, it may not be hazardous to handle the contents of the pit for use as manure.

e) **Optimal Pit Emptying Frequency**

The minimum acceptable design interval between successive manual desludging of each twin leach pit could be one and a half years. But to provide a reasonable degree of operational flexibility, it is desirable to provide three years storage volume in urban areas and a two-year period in rural areas.

f) **Size of Pits**

Sizes of leach pits, [designed as per the above criteria, for different number of users, using water ablation and for different sub- soil water levels], with 3 years sludge storage volume, are given in Table 21.6. The surface area of these sizes of pits is adequate, enough for soils with long term infiltrative rate down to 20 liters per sq.m. per day

TABLE 21.6
SIZES OF LEACH PITS

	5 users		10 users		15 users	
	dia	depth *	dia	depth *	dia	depth *
Dry Pits	900	1000	1100	1300	1300	1400
Wet Pits	1000	1300	1400	1400	1600	1500

* Depth from bottom of pit to invert level of incoming pipe or drain (all dimensions are in mm)

The above depths should be increased by 300 mm to provide a free board depth of pit from invert level of pipe or drain to bottom of pit cover. A typical pour flush latrine with circular pits is shown in Fig.21.3.

g) Design of Pits under Different Conditions

In water Logged Area: The pit top should be raised by 300 mm above the likely level of water above ground level at the time of water logging. Earth should then be filled well compacted all round the pits upto 1.0 m distance from the pit and upto its top (Fig.21.4.). The raising of the pit will necessitate raising of latrine floor also.

In high sub-soil water level: Where the sub-soil water level rises to less than 300 mm below ground level, the top of the pits should be raised by 300 mm above the likely sub-soil water level and earth should be filled all round the pits and latrine floor raised as stated above (Fig.21.5).

In rocky strata: In rocky strata with soil layer in between, the leach pits can be designed on the same principle as those for low sub- soil water level and taking the long term infiltrative capacity as 20 liter per sq.m. per day. However, in rocks with fissures, chalk formations, old root channels, pollution can flow to very long distances; hence these conditions demand careful investigation and adoption of pollution safeguards as stated in para below.

In black cotton soil: Pits in black cotton soil should be designed taking infiltrative rate of 10 liters per sq.m. per day. However a vertical fill (envelope) 300 mm in width with sand, gravel or ballast of small sizes should be provided all round the pit outside the pit lining.

Where space is a constraint: Where circular pits of standard sizes cannot be constructed due to space constraints, deeper pit with small diameter (not less than 750 mm), or combined oval, square or rectangular pits divided into two equal compartments by a partition wall may be provided. In case of combined pits, the partition wall should not have holes. The partition wall should go 225 mm deeper than the pit lining and plastered on both sides with cement mortar, (Fig 21.6).

21.3.2 Construction of Pour Flush Latrine

21.3.2.1 SQUATTING PAN AND TRAP

The pan could be ceramic, glass Fibre plastic (GRP), PVC, PP, Cement Concrete or Cement Mosaic. Ceramic are the best but costliest. Mosaic or cement concrete pans have the advantage that these can be manufactured locally by trained masons but the surface tends to become rough after long use. Their acceptance is less compared to other types.

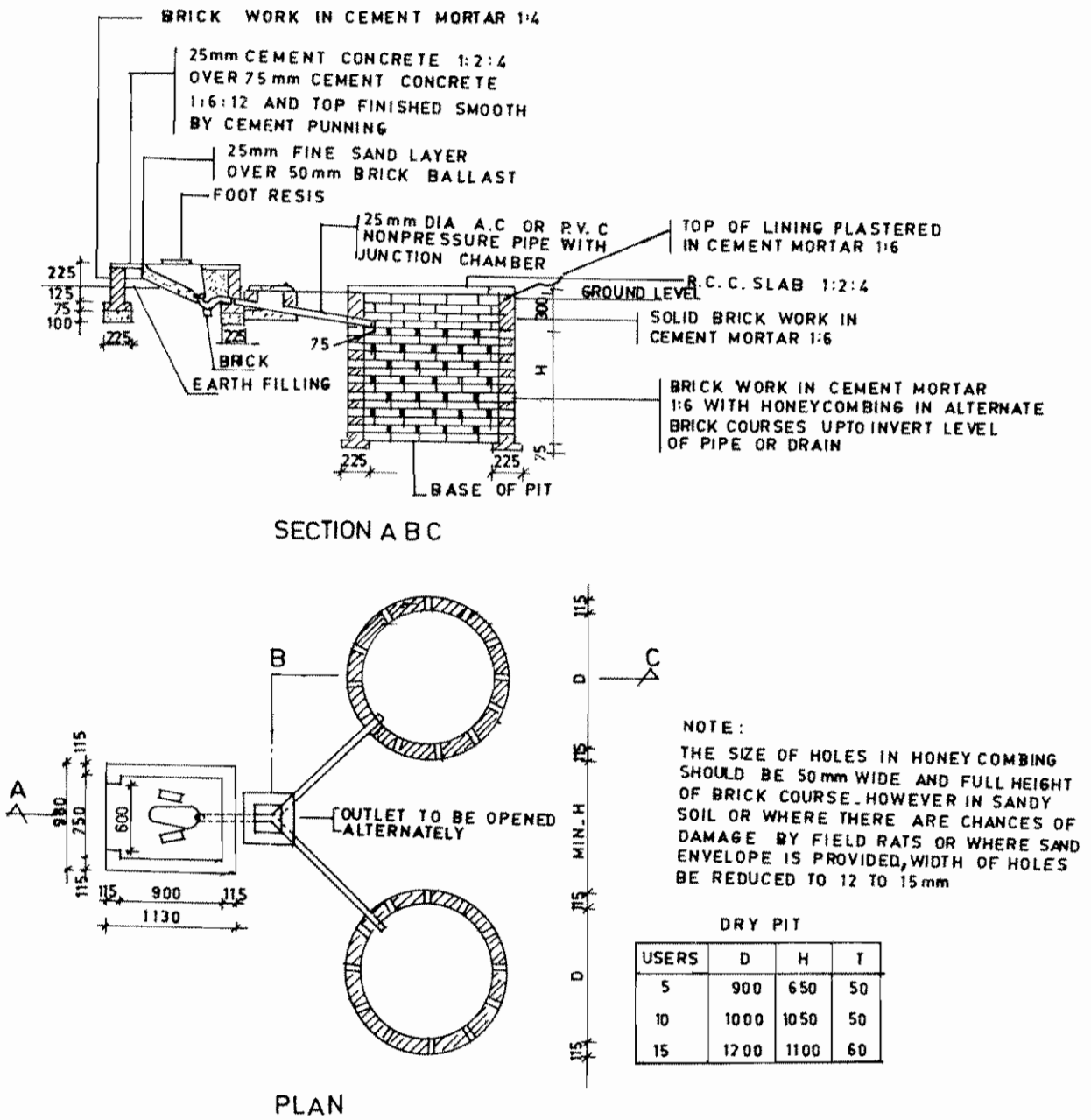
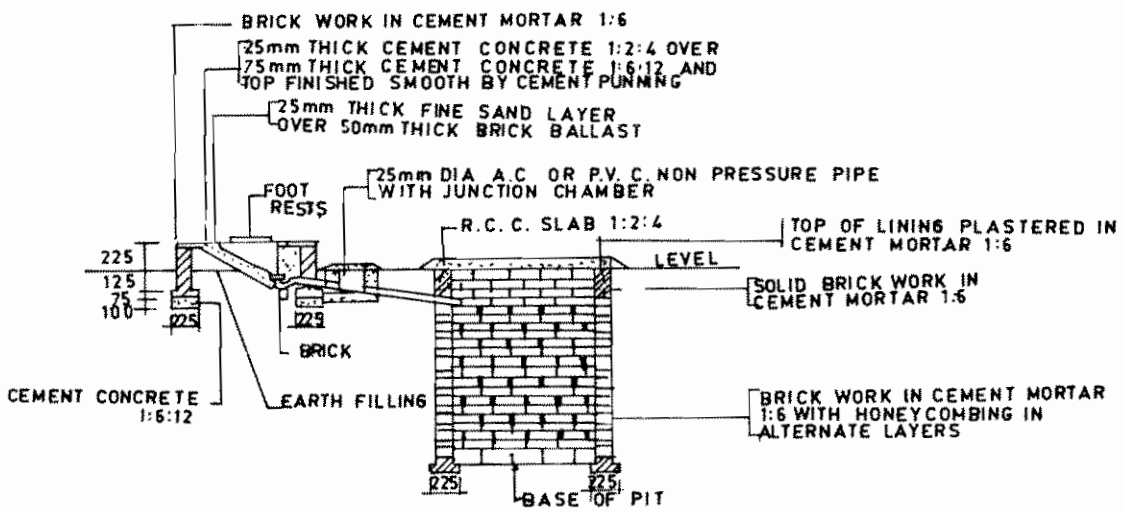
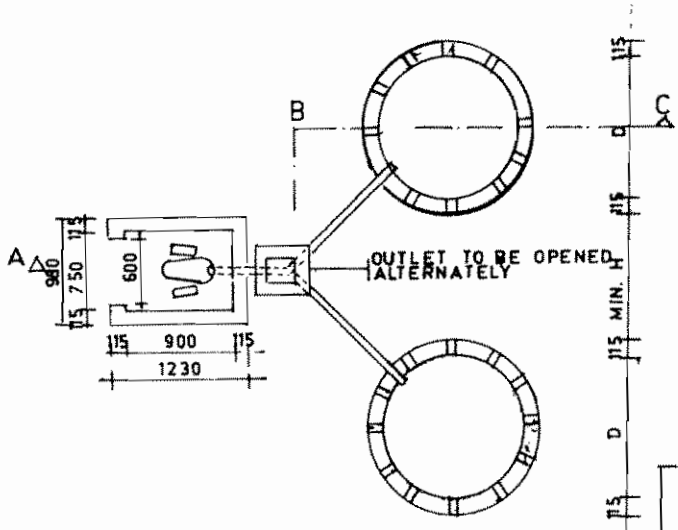

FIG.21.3(a):POUR FLUSH LATRINE WITH CIRCULAR PITS



SECTION A.B.C



PLAN

NOTE:
 THE SIZE OF HOLES IN HONEYCOMBING SHOULD BE 50mm WIDE AND FULL HEIGHT OF BRICK COURSE HOWEVER IN SANDY SOIL OR WHERE THERE ARE CHANCES OF DAMAGE BY FIELD RATS OR WHERE SAND ENVELOPE IS PROVIDED WIDTH OF HOLES BE REDUCED TO 12 TO 15 mm.

WET PIT			
USERS	D	H	T
5	900	1250	50
10	1200	1400	60
15	1600	1880	75

FIG. 21.3(b) POUR FLUSH LATRINE WITH CIRCULAR PITS

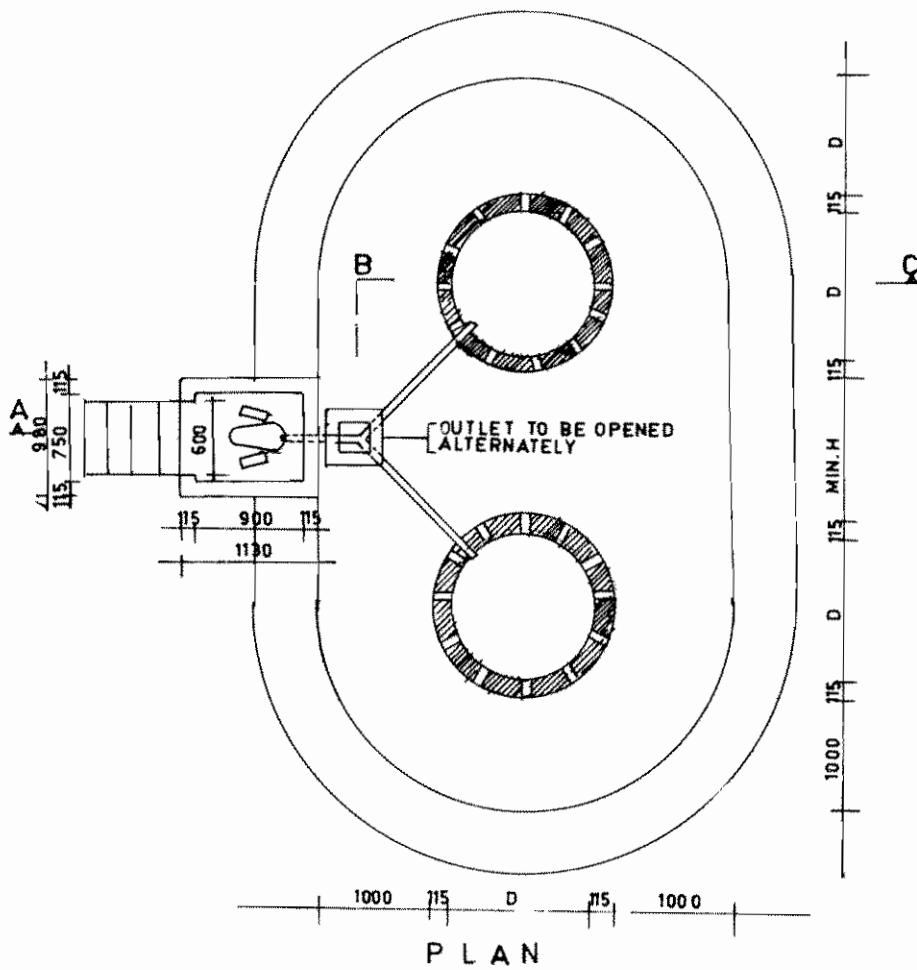
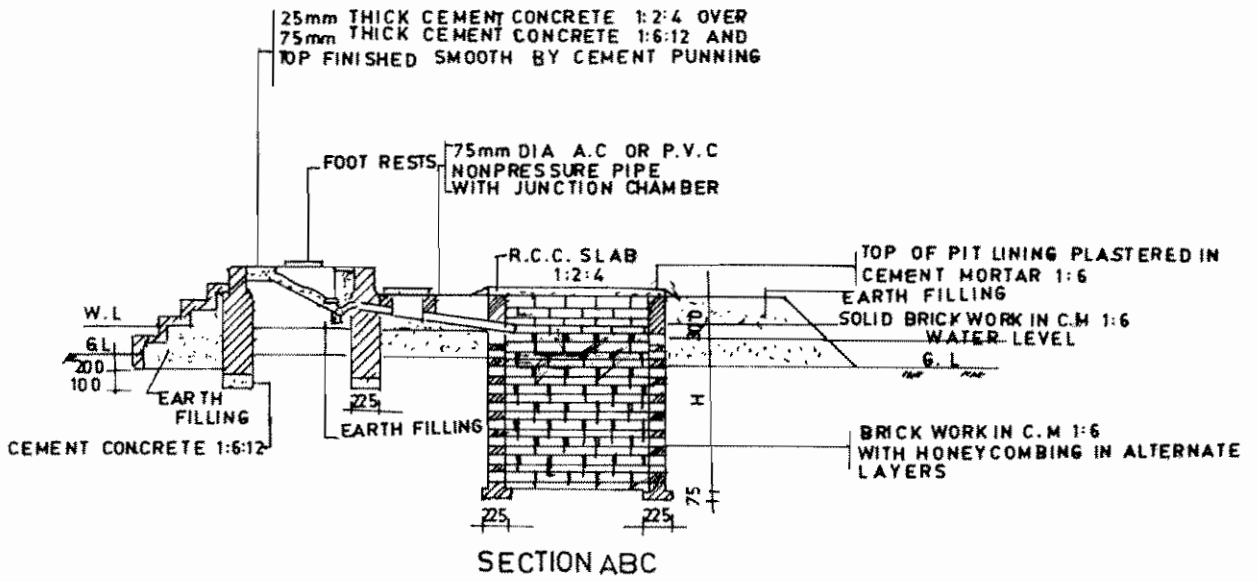
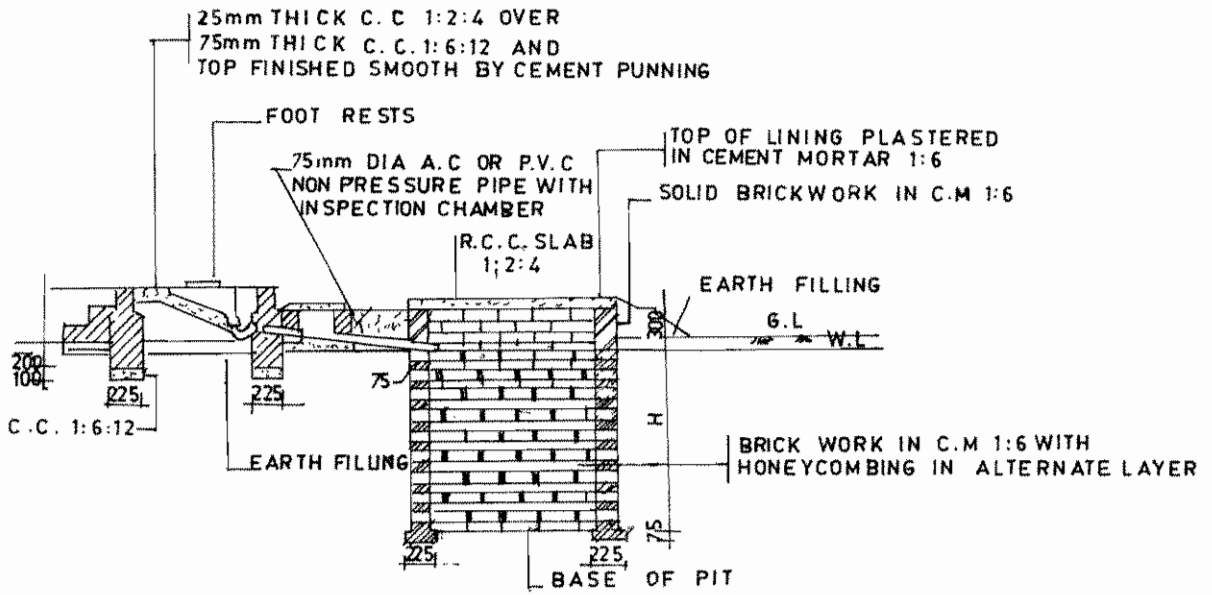

FIG.21.4 : POUR FLUSH LATRINE IN WATERLOGGED AREAS



SECTION ABC

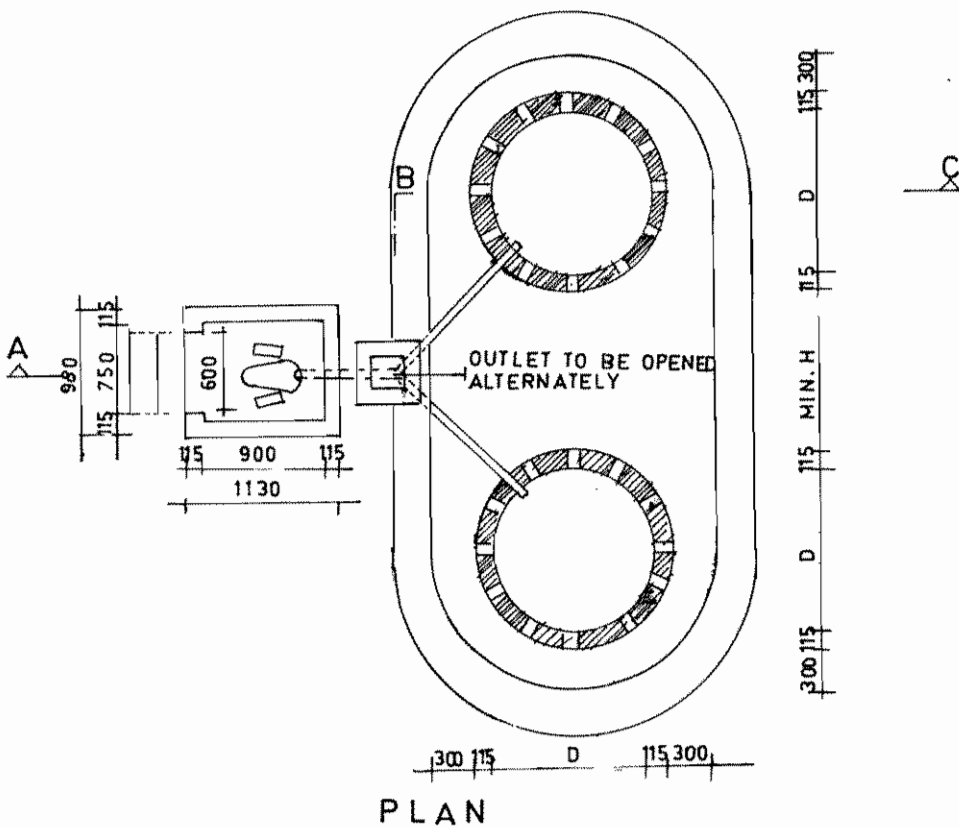
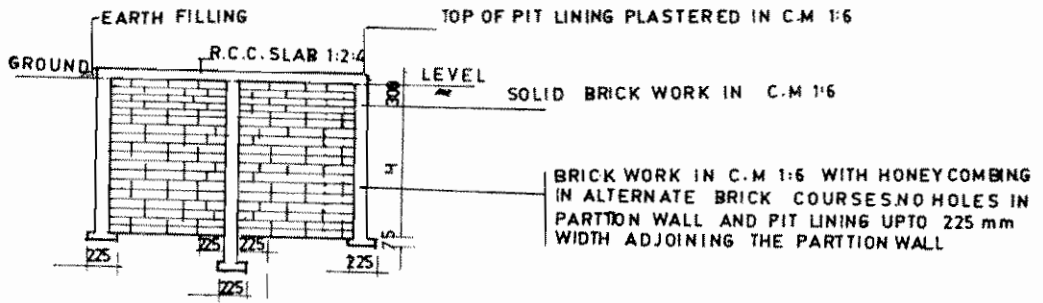
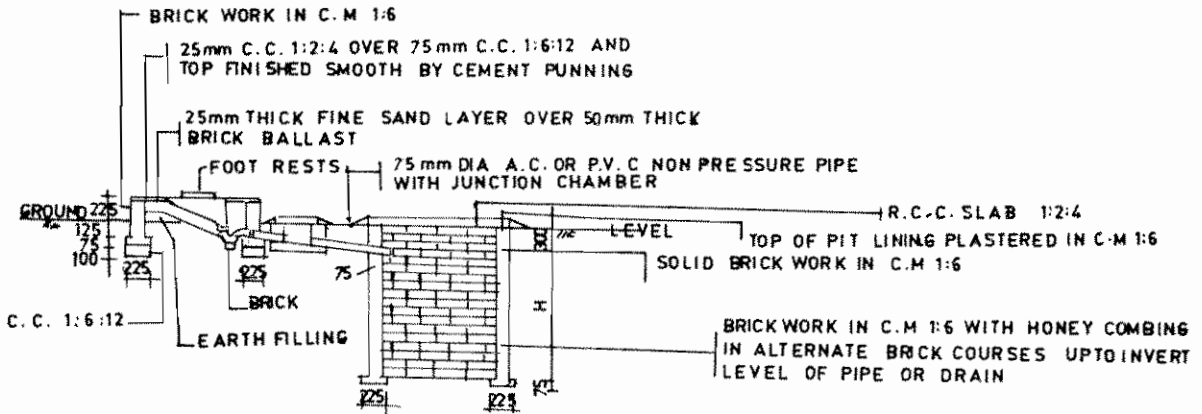

FIG.21.5 : LEACH PITS IN HIGH SUBSOIL WATER LEVEL



SECTION D-E



SECTION A-B-C

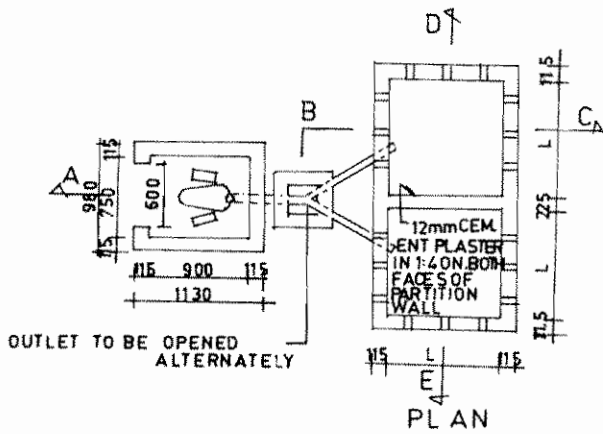

NOTE:
 THE SIZE OF HOLES IN HONEYCOMBING SHOULD BE 50mm WIDE AND FULL HEIGHT OF BRICK COURSE IN SANDY SOIL OR WHERE THERE ARE CHANCES OF DAMAGE BY FIELD RATS OR WHERE SAND ENVELOPE IS PROVIDED WIDTH OF HOLES BE REDUCED TO 12 TO 15mm

FIG.21.6: POUR FLUSH LATRINE WITH COMBINED PITS

Traps for ceramic pans are made of the same material but of GRP pans. HDPE traps are used. For mosaic pans, traps are of cement concrete.

21.3.2.2 FOOT-RESTS

These can be of ceramic, cement concrete, cement mosaics or brick plastered. The top of the foot rest should be about 20 mm above the floor level and inclined slightly outwards in the front.

21.3.2.3 PIT LINING

The pits should be lined to avoid collapsing. Bricks joined in 1:6 mortar are most commonly used for lining. Locally, manufactured bricks should be used wherever available. Stones or laterite bricks of cement concrete rings could also be used depending upon their availability and cost. However, for ease of construction, use of concrete rings will be advantageous where the subsoil water level is above the pit bottom.

The lining in brick work should be 115 mm thick (half brick) with honey combing upto the invert level of incoming pipe or drain; the size of holes should be about 50 mm wide upto the height of the brick course. For ease of construction, holes should be provided in alternate brick courses. In case the soil is sandy and sand envelope is provided, the width of openings should be reduced to 12 to 15 mm. Where foundation of building is close to the pit, no holes should be provided in the portion of lining facing the foundation and in rest of the lining, 12 to 15 mm wide holes be provided. The lining above the invert level of pipe or drain upto the bottom of pit's cover should be in solid brick work i.e. with no openings.

The concrete rings used for lining should be 50 mm thick, about 450 mm in height and of required diameter in 1:3:6 cement concrete and have 40 mm circular holes staggered about 200 mm apart. The rings are not jointed with mortar but are put one over the other. The rings above the invert level of pipe or drain should not have holes and are jointed with cemented mortar.

21.3.2.4 PIT BOTTOM

Except where precautions are to be taken to prevent pollution of water sources, the pit bottom should be left in natural condition.

21.3.2.5 PIT COVER

Usually RCC slabs are used for covering the pits, but depending upon the availability and cost, flag stones can also be used. The RCC Slab may be cast in pieces for convenience of handling and centrally cast.

21.3.2.6 LEACH PIT CONNECTION

The toilet pan is connected to the pit through a 75 mm brick channel of 'U' shape covered with loosely jointed bricks or 75 mm dia A.C. or PVC non-pressure pipe laid in 1: 15 gradient. In case pipes are used, a chamber of minimum size 225 x 225 mm is provided at the bifurcation point to facilitate clearing and allowing flow to one pit. In case of drain 'Y' portion of the drain serves the purpose by taking out the brick cover.

21.3.3 Pollution Safeguards

In order that the pollution risk of ground water and water sources in minimal, the following safeguards should be taken while locating the pits.

21.3.3.1 SAFE DISTANCE FROM DRINKING WATER SOURCES

In dry pits or unsaturated soil conditions, i.e. where the distance between the bottom of the pit and the maximum ground water level throughout the year is 2 M and more.

- a. The pits can be located at a minimum distance of 3 m from the water sources such as tube wells and dug wells if the effective size (E.S.) of the soil is 0.2 mm or less, and
- b. for coarser soils (with E.S. greater than 0.2 mm) the same distance can be maintained if the bottom of the pit is sealed off by an impervious material such as puddle clay or plastic sheet and 500 mm thick envelope of fine sand of 0.2 mm effective size is provided around the pit.

In wet pit saturated soil conditions, i.e. where the distance between the bottom of the pit and the maximum ground water level during any part of the year is less than 2 m.

- a. The pits can be located at a minimum distance of 10 m from the water sources such as tubewells and dug wells, if the E.S. of the soil is 0.2 mm or less and
- b. For coarser soils (with E.S. more than 0.2 mm), minimum distance of 10 m can be maintained if the pit is sealed off by an impervious material such as puddle clay or plastic sheet and a 500 mm thick envelope of fine sand of 0.2 mm effective size is provided all round the pit.

21.3.3.2 SAFE DISTANCE FROM WATER SUPPLY MAINS

Lateral distance between the leach pit and the water mains should be at least 3 m provided the water table does not rise during any part of the year above the pit bottom and the inlet of the pipe or drain to the leach pit is below the level of water main. If the water table rises above the bottom of the pit, the safe lateral distance should be kept as 8 m. If this cannot be achieved, the pipes should be completely encased to a length of at least 3 m on either side of the pit.

When the pits are located either under the foot path or under the road, or the water supply main is within a distance of 3 m from the pits, the invert of the inlet pipe should be kept at least 1 m below the ground level. This would ensure that the liquid level in the pits does not reach the level of the water main as the water mains are generally laid at 0.9 m depth.

The water pipe should not cut across the pit, but where this is unavoidable, the water pipe should be completely encased for length of 3 m on either side of the pit including the portion across the pit to prevent infiltration or exfiltration.

21.3.3.3 LOCATION OF PITS

The ideal position for locating the pits is that the pits are placed symmetrically at the backside of pan. The pits may be located within premises, under foot path or narrow lanes or under road. The minimum space between two pits should be equivalent to at least the effective depth (distance between the invert level of pipe or drain and bottom of the pit) of the pit, spacing can be reduced by providing an impervious barrier like cut off screen or puddle wall.

In many cases, the space available for constructing leaching pits may be small and placement of pits near existing structure may be unavoidable. The digging of pits and subsequent seepage may disturb the soil around the pits. The safe distance of the leaching pits from the foundations of existing building depends upon the soil characteristics, depth as well as type of foundation of the structure, depth of the leaching pits etc., and varies from 0.2 to 1.3 m.

However, in cases where the leaching pits are quite close to the existing building foundation, the opening in the brick work lining of the leaching pit may be reduced to 12 - 15 mm.

Where the bottom of the pit is submerged below the maximum ground water level :

- i) the top of the pits should be raised above the ground level, if necessary, so that the pipe into the pit is at least 0.75 m above the maximum ground water level
- ii) the sand envelope is taken upto 0.3 m above the top of the inlet pipe and confined suitably to exclude any surface drainage including rain water directly entering the sand envelope
- iii) in mound type latrines, 1 m high earth filling be provided at least 0.25 m beyond the sand envelope with the edges chamfered to lead away the rain or surface water and
- iv) the honeycomb brick work for the pit lining should be substitute by brick work in cement mortar 1:6 with open vertical joints, i.e., without mortar. Where sand is not available economically, local soil of effective size of 0.2 mm can also be used.

21.3.3.4 SUB-SOIL CONDITIONS

In depression and water logged areas location of pits should be avoided, as far as possible, in depression where waste water or rain water is likely to remain collected all round and over the pits. If, it cannot be avoided or the pits are to be constructed adjacent to ponds or tanks, the top of pits should be raised to 0.6 m to 0.8 m above the ground level and earth filling be done all round the pits upto a distance of 1.5 m right upto the pit top. The raising of pit may necessitate raising of the latrine floor also.

21.4 AN OVERVIEW OF OTHER ALTERNATIVE ON-SITE SANITATION METHODS

An overview of various other low cost on-site sanitation methods prevalent in out country is given below :

21.4.1 Bucket/Dry Latrine

The Bucket/dry type latrine are still widely used in poor urban and semi urban areas, both for households and community toilets. The excreta is manually removed periodically - varying from daily to few days interval, by the scavengers to a trench for composting. A bucket or any other suitable container is placed either on the floor in between the foot rests or in small vault under the latrine floor. In the latter case the latrine servicing can be done from outside, without entering the latrine cubicle. The initial cost of the bucket latrine is low, but the servicing cost by the scavengers is high. In addition, it has several other disadvantages like, major health hazards and social stigma for the scavengers, foul smell, breeding of flies and mosquitos. Therefore this practice should be stopped and the existing bucket/dry latrines should be converted into low cost pour flush latrines with leach pits or connected to sewers, wherever feasible.

In place of leach pits, the night soil can be emptied mechanically using vacuum suction device into a tanker for safe disposal. Thus direct handling of night soil by scavengers will be eliminated.

21.4.2 Trench Latrine (Shallow Type)

This type of latrines are used as a temporary measure during fairs, etc. These consists of rows of parallel trenches of 0.9 m long, 0.3 m wide and 0.3 to 0.6 m deep and provided with privacy screens. A distance of about 0.6 m is maintained between each trench. The faeces, urine and ablution water fall directly into the trench. The trench should be filled up by the excavated earth after every use. This practice being insanitary, may be discarded.

21.4.3 Bore Hole latrine

This type of latrine is constructed where the space available is very little. It consists of a circular hole of 0.30 to 0.40 m diameter and 5.0 to 6.0 m deep, dug in the ground by means of auger. The bore hole is covered with a suitable concrete squatting slab with a central opening and foot rests of about 0.85 m dia. Once the bore is filled up, the squatting slab and the super structure have to be moved to a new bore and the old bore should be filled up with the earth excavated from the new bore. Disadvantages with this type of latrines are foul smell and breeding of flies and mosquitoes.

21.4.4 Dug well Latrine

The dug well latrine consists of a circular pit of 3 to 4 m deep. A brick or concrete ring with an earth mound is provided on top of the pit so that the squatting pan is placed about 200 mm above the ground level. Such an arrangement will prevent the entry of rain water into the pit. The shifting of superstructure to another pit or immediate desludging of the pit, when the pit gets filled up are the major disadvantages of this type latrine. Other disadvantages with this type of latrines are foul smell and breeding of flies and mosquitoes.

21.4.5 Aqua Privy

Aqua privy latrine is a simplified form of septic tank and was earlier used in several regions of our country. The Aqua privy consists of a masonry tank filled with water, a squatting pan or a platform placed above the tank and a ventilation pipe. A long chute or a pipe from the squatting pan is submerged in the tank water. The excreta falls through this chute or pipe into the tank and undergoes anaerobic digestion, as happens in a septic tank. The accumulated digested sludge from the tank is to be removed periodically. To compensate for evaporation and leakage losses and to maintain the water seal - i.e. submergence of the chute in the water, water is to be added every time after its use. In practice, water seal maintenance has proved to be difficult and in some cases even sullage discharge connection was not adequate. Absence of effective water seal often resulted in foul smell, mosquito and fly breeding, visibility of excreta floating through the pipe, splashing of water etc. In addition, the excreta sticks to the pipe and encourages breeding of flies and mosquitoes. In view of these reasons, aqua privies are not recommended.

21.4.6 Ventilated Improved Pit Latrine (VIP Latrine)

Ventilated Improved Pit (VIP) Latrines can provide most of the health and convenience benefits of conventional water borne sewerage but at a fraction of its cost.

Satisfactory odor control is achieved with a ventilation rate (vent pipe air flow rate) of 10 m³/h, minimum vent pipe sizes to achieve this are 100 mm diameter for AC or PVC pipes, 300 mm diameter for rural vent pipes made from cement - rendered reeds, bamboos or similar materials, and 180 mm square for brick work. For permanent installation, especially in congested urban areas where latrines may need to be placed very close to living quarters or in areas where mean wind speeds may fall below 0.5 m/s, and where minimizing cost is not an over-riding consideration, adoption of ventialtin rate of 20 cu.m./hr. will

provide a greater factor of safety; corresponding vent pipe sizes will be 150 mm for AC or PVC pipes, 200 mm for rural vent pipes, and 230 mm square for brick work.

In all cases the vent pipe should extend 500 mm above the highest part of the roof. Opening in the latrine super-structure (e.g. doors) should face into the direction of the prevailing wind in order to maximize ventilation rates. The fly-screen at the top of the vent pipe should have apertures no greater than 1.2 mm x 1.5 mm in order to prevent ingress and egress of insects. These latrines have limited application in Indian Conditions, since water is used for ablution.

21.5 NIGHT SOIL DIGESTERS

The night soil can be anaerobically digested either alone or in combination with animal dung. The characteristics of night soil are somewhat different from those of the cow dung and are presented in Table 21.7

TABLE 21.7
CHARACTERISTICS OF NIGHT-SOIL AND COW-DUNG

Characteristics	Night Soil	Cow Dung
1. Moisture content, %	85 - 90	74 - 82
2. Volatile solids as % of Total Solids	80 - 88	70 - 80
3. Total Nitrogen as N, % on dry basis	3 - 5	1.4 - 1.8
4. Total Phosphorus as P ₂ O ₅ , % on dry basis	2.5 - 4.4	1.1 - 2.0
5. Potassium as K ₂ O, % on dry basis	0.7 - 1.9	0.8 - 1.2

The night soil is richer in nitrogen and phosphorus in comparison to cow dung

21.5.1 Design Criteria

The design criteria for night soil digester are listed in Table 21.8

TABLE 21.8
DESIGN CRITERIA AND PERFORMANCE PARAMETERS FOR DIGESTER

Sl. No.	Item.	Magnitude
1.	Volumetric Organic Loading, Kg VS/m ³ .d	1.6
2.	Hydraulic residence time, d	25 - 30
3.	Solids concentration of slurry fed to digester, %	5
4.	Volatile solids destroyed during digester	45 - 55
5.	Gas yield, m ³ /kg of VS added m ³ /capita/d	0.5 0.034

The night soil digesters are constructed in a similar manner as dung digesters and essentially consist of following components:

- i) Inlet tank with a feed pipe leading to digester
- ii) Digester tank with fixed or floating dome for gas collection
- iii) Outlet pipe from digester discharging digested slurry into a masonry chamber.

21.6 MINI PACKAGE TREATMENT PLANTS

Mini Package Treatment Plants may be considered for multi-storeyed buildings, housing complexes and hospitals for unsewered and inadequately sewerred areas

CORROSION PREVENTION AND CONTROL

22.1 GENERAL

Corrosion is the phenomenon of the interaction of a material with the environment (water, soil or air) resulting in its deterioration. There are many types of corrosion, the major types being galvanic, concentration cell, stray current, stress and bacterial. Wastewater collection and treatment systems are more prone to corrosion in view of the nature of the wastewater. Since wastewater contains solids which are more likely to cause abrasion in sewers, pumps and their components thus removing the protective coating and accelerating the corrosion process, corrosion control becomes all the more important in wastewater systems. It is particularly acute in areas where sewage strength is high, sulphate content of water is substantial and average temperature is above 20° C. The corrosion problem in wastewater systems can be categorised as (1) Corrosion of sewers and (2) Corrosion of treatment systems.

22.2 CORROSION OF SEWERS

The most widely used materials for sewers are reinforced concrete, stoneware, asbestos cement and cast iron. The development of plastics, fibre glass and other synthetic materials has increased the choice of piping materials. For gravity sewers the usual practice is to use vitrified stoneware pipes for smaller sizes and cement concrete pipes for larger sizes. For pumping mains, CI pipes are generally used. Factors such as climate and topography, high temperature, flat grades and long length of sewers may favour the development of highly septic, sulphide containing wastewater in the sewer line. Industrial wastes may aggravate these problems by the introduction of high concentration of pollutants and/or large volumes of hot water that accelerate chemical and biological reaction rates. Concrete sewers are the worst affected because of sulphides in wastewater.

22.2.1 Corrosion due to Biological Reactions

Hydrogen Sulphide may be produced biologically in sewers by (1) the hydrolysis of organic compounds containing sulphur and (2) by reduction of sulphates. Sewage contains a variety of Sulphur - bearing organic compounds (usually at concentration of 1 to 5 mg/l) and inorganic sulphates which find their way through drinking water, industrial water or sea water intrusion. Hydrogen sulphide in sewer is usually produced by bacteriological reduction of sulphates. Hydrogen sulphide gas by itself is not injurious to cement concrete. It gets readily oxidised by dissolved oxygen or by several bacterial species. Oxygen which is normally present in the air between the crown and the sewage, H₂S, a necessary prerequisite for sewer corrosion and CO₂ are usually present in the sewer air. In the presence of air, H₂S gets oxidised to sulphuric acid and this sulphuric acid reacts with the cement constituents of concrete. In fact, it reacts with the lime in the cement concrete to form calcium sulphate which in turn, reacts with the calcium aluminates in the cement to form calcium sulfo-aluminates. Expansion caused by these reactions results in spalling of the surface of the concrete, thereby exposing underlying layers of concrete to further attack. If the corrosion products adhere to the surface of the concrete a certain measure of protection against further acid attack is provided. Sulphuric acid, in fact, does not and cannot penetrate into normal concrete. Acid attack therefore takes place at the surface only. The most outstanding character of this form of corrosion is the fact that it only occurs above the water line in the sewer. In other words, it is the crown portion of the pipe which gets corroded and this phenomenon is referred to as crown corrosion. Due to this corrosion, the reinforcement gets exposed and the sewer gets damaged.

22.2.2 Factors Influencing Sulphide Generation

The factors that influence sulphide generation in sewers include: (i) Temperature of sewage, (ii) Strength of sewage, (iii) velocity of flow, (iv) age of sewage, (v) pH of sewage, (vi) sulphate concentration and (vii) ventilation of the sewer.

22.2.2.1 TEMPERATURE

Since sulphide generation is a biological phenomenon, it is obvious that sewage temperature influences the rate of sulphide generation. Temperature below 20° C generally will not cause any appreciable sulphide build up. From 20° C to 30° C, the rate of sulphide generation increases at about 7% per °C rise in temperature and is maximum at 38° C.

22.2.2.2 STRENGTH OF SEWAGE

A high concentration of bacterial nutrients in sewage will lead to an increased rate of sulphide generation. For any specified sewage temperature and flow condition in a sewer, there is a limiting sewage strength, usually less than 80 mg/l of BOD, below which a build up of hydrogen sulphide will practically cease. However, it is possible in a long force main or at other locations where oxygen is shut off from the sewage for a few hours, that sulphide build up may occur even with low values of BOD.

22.2.2.3 VELOCITY OF FLOW

The velocity should be both self-oxidising and self cleansing. If the velocity of flow is great enough to keep the submerged surfaces of the sewer free from slimes, no generation of H₂S will occur.

The velocity necessary to prevent the build up of sulphides in flowing sewage corresponding to different values of the effective BOD, (BOD_T) are shown in Table 22.1.

TABLE 22.1
REQUIRED VELOCITY TO PREVENT SULPHIDE BUILD UP

BOD _T mg/l	Velocity, m/sec
55	0.30
125	0.45
225	0.60
350	0.75
500	0.90
690	1.05
900	1.20

$$\text{BOD}_T \text{ (Effective BOD)} = 5 \text{ day } 20^\circ \text{ C BOD} \times (1.07)^{T-20}$$

Where T is the temperature in °C.

In determining the velocity to be used in design, the effective BOD should be calculated for the period of the year which gives the maximum value.

22.2.2.4 AGE OF SEWAGE

The oxidation-reduction potential of sewage which in turn is influenced by the age of sewage seems to be one of the important factors contributing to sulphide build up in the lower reaches. When septic sewage is discharged from a collecting system, an Imhoff tank, or from a septic tank into an outfall, it should be treated before it goes into the sewer. When outfall grades are steep, the problem is particularly acute since high turbulence can release the sulphides causing odour and corrosion problems. Long detention times in forced mains greatly influence the generation of sulphides.

The possible sulphide build up in a filled pipe can be roughly estimated as

$$\Delta C_s = 0.066t BOD_T \left(\frac{1 + 0.0004d}{d} \right)$$

where ΔC_s = Increase of Sulphide concentration in the force main in mg/l

t = Detention time in the main in minutes

d = Pipe diameter in mm

22.2.2.5 HYDROGEN ION CONCENTRATION

Sulphide producing organisms are known to have a considerable adaptability so that pH value is not likely to have much effect on the rate of generation in sewers within the pH of 6-8. If the pH value is above 9.0 or below 5.5, sulphide generation will be affected.

22.2.2.6 SULPHATE CONCENTRATION

The more the concentration of Sulphate, the more is its reduction to H_2S .

22.2.2.7 VENTILATION

Ample ventilation through sewers will help in carrying away the generated H_2S , supply additional oxygen to the sewage and keep the walls free of moisture and reduce the tendency for sulphuric acid formation and attack of concrete. Ventilation is particularly important in locations of turbulent flow. Either by better natural ventilation or by forced ventilation by fans, one or more of the necessary factors for optimal bacterial activity can be made limiting. However, it is often very difficult and expensive to provide enough ventilation to prevent corrosion.

22.2.3 Sulphide Control Procedures

The following are some of the criteria that may be taken into account in preventing or controlling sulphide build up and consequent odour and/or corrosion.

22.2.3.1 DESIGN OF SEWERS

In the design of sewer systems, consideration should be given to the desirability of maintaining velocities sufficient to avoid sulphide build up and of minimising pressure lines and points of high turbulence. The designer should take into consideration topography, grades of sewers, ventilation, materials of construction, sewage temperature and strength etc.

Some of the design features which should be considered are as follows :

One of the important factors in the control of H_2S is the velocity of flow. The limiting velocities for prevention of sulphide generation vary with temperature and effective BOD. The velocities given in Table.22.1 are believed to be the minimum that should be used. An allowance of 25% in the velocity should be made as a factor of safety and if industrial wastes are present with a higher content of dissolved organic matter, it may be necessary to increase this allowance to 50%. Where it is impractical to provide a sewer gradient in design to give these limiting velocities, other means of controlling sulphide generation should be considered. Velocities giving high, single point turbulence may, however, result in sulphide release and severe odour and/or corrosion.

Except in the cases where sewage is quite weak and in a fairly well aerated condition, high sulphide generation because of large slime areas can be expected in completely filled lines. Force mains, therefore should be kept to a minimum.

Since biological activity is concentrated largely in the slime layer, it increases with an increase of the wetted perimeter. The oxygen uptake is proportional to the surface width of the stream. Therefore, it follows that deep flow in a pipe is more conducive to sulphide generation than shallow flow. Accordingly where sulphide generation is a critical consideration, a larger pipe is always better than a smaller one for any given slope and sewage flow.

Turbulence caused by high velocities for short distances or improper design of junction manholes permitting sewage lines to intersect at right angles or at different elevations should be avoided as turbulence can cause excessive release of H_2S even where sewage contains only a small amount of dissolved sulphides.

Concrete with a low water-cement ratio of suitable workability, thorough mixing, proper placing and sufficient curing is preferred for sewers.

22.2.3.2 CONTROL OF SEWAGE CHARACTER

Trade wastes containing dissolved sulphides should not be allowed into the sewers. High sulphate concentrations arising from the discharge of tidal or sea water to the sewer should be controlled. The oxidation reduction potential of the sewage can be increased and the rate of generation of H_2S slowed down by steps which include the partial purification of sewage allowed into the sewers by sedimentation or by high rate treatment on filters. Effective BOD of sewage depends upon sewage strength and temperature. By reducing sewage strength and/or temperature, effective BOD as well as minimum velocity required can be reduced. Strength of sewage can be reduced in some cases by diluting sewage with unpolluted water. It must be realised, however, that dilution reduces the waste-carrying capacity of the sewer.

Where velocities are inadequate to control the formation of H_2S or where completely filled lines are encountered as in force mains, supplemental aeration by the use of compressed air may be desirable. Air injection would prevent hydrogen sulphide building up and in any case will greatly reduce generation.

Air addition at about 10 lpm for each cm of pipe diameter is necessary. Care must be taken to prevent the formation of air pockets in such lines, since experience has shown that some H_2S will form on the walls at the points of such air pockets and corrosion will occur.

22.2.3.3 CLEANING OF SEWERS

Removal of slime and silt has the effect of reducing sulphide generation. Periodic cleaning of sewers by mechanical or chemical means is necessary. Any partial blocking of the sewer by debris will result in retardation of flow and consequent anaerobic decomposition of deposited sludge. Periodic mechanical cleaning and flushing of sewers can reduce average sulphide generation by 50%. A good continuing programme of mechanical cleaning is probably the basic foundation for any control programme.

Sulphuric acid is effective in reducing slimes. Intermittent use of sulphuric acid was found to be useful in removing slimes on the submerged walls. Caution must be exercised in the use of sulphuric acid for this purpose, as on acidification, iron sulphide, that may be present on sewer walls, may cause an initial release of H_2S sufficient to be fatal to any workmen inside the sewer. The shift of pH value also changes all the ionised sulphide (in the flow) to H_2S .

Slaked lime, $Ca(OH)_2$, is probably a more suitable chemical for chemically treating slime since no corrosion damage will result from it and sulphide release will not occur. It has been found that if the slimes are subject to a lime slurry of about 8,000 mg/l for 45 minutes, they will be inactivated for periods of from 3-14 days depending upon flow and sewage characteristics.

22.2.3.4 CHLORINATION

Chlorine has been successfully used in controlling sulphide generation for many years. Chlorine is effective in three ways (i) it destroys sulphides by chemical reaction, (ii) it reduces biological activity and produces mild oxidising compounds in the sewage, and (iii) it destroys the slimes. An approximate dosage of 10 to 12 mg/l of chlorine is sufficient. When excess chlorine is applied, it leaves the sewage in an oxidised state, and prevents the re-appearance of sulphide for some distance downstream.

Addition of iron salts : This converts dissolved sulphide to insoluble iron sulphide. This is inexpensive for reducing high concentrations of sulphides to about 1.0 mg/l, but not effective for complete elimination of sulphide. Subsequent dilution will help to reduce dissolved sulphide to a negligible level.

Addition of Zinc salts : This reduces sulphides to zero level. Added at any upstream point, it is effective until all the Zinc has combined with sulphide giving ZnS . The ratio of Zn : S is 2.04. Zinc solution can be prepared from scrap zinc and waste acids.

If the pH value of sewage is increased to above 8.5, H_2S in sewage will be more dissociated resulting in reducing the rate of emission of H_2S into the sewer atmosphere.

Where ponding conditions exist, nitrates have been useful in sulphide control. The cost of nitrate treatment is generally high.

22.2.4 Materials of Construction

When corrosion cannot be prevented by design, maintenance or control of wastes entering the sewer, consideration must be given to corrosion resistant materials such as vitrified-clay or to protective linings of proven performance. Plastic pipes may also be used if accepted in all other respects.

It is possible that supersulphated metallurgical cement, pozzolana-portland cement mixtures or

portland cement low in tricalcium aluminate may be more resistant to attack than normal portland cement.

On concrete pipe, extra wall thickness (sacrificial concrete) sometimes is specified to increase pipe life in the event corrosive conditions develop. On reinforced concrete this takes the form of added cover over the inner reinforcing steel.

Another method of modifying the composition of concrete is by the use of limestone or dolomite aggregate in the manufacture of the pipe materials. The use of such aggregates increases the amount of acid-soluble material in the concrete which prolongs the life of the pipe in corrosive environments. The rate of acid attack of limestone or dolomite aggregate pipe may be only about one fifth as great as when granite aggregate is used. Unfortunately, not all limestone and dolomite aggregates exhibit the same resistance to this form of corrosion. Accordingly tests should be made before limestone or dolomitic aggregate is used. Aluminous cement has initial resistance to acid attack. Its corrosion products are also not extensive. So it may have some use in sewer structures.

22.2.5 Sewer-Protection

Protection of sewer structures by lining or coating against H_2S attack can also be considered if other methods of control are impracticable.

22.2.5.1 LINERS

A plastic polyvinyl chloride sheet, having T-shaped protections on the back which key into the pipe wall at the time of manufacture is one of the successful lining materials. Vitrified clay of low porosity has also been used as a liner. In regions where high sulphides and high production of H_2SO_4 can be expected, problems still remain. Cement mortar joints are subject to attack. Bituminous joints are emulsified and dissolved by soaps, oil and grease. Acid proof cement joints offer the best protection but they are costly. Some type of plastic coatings and/or linings for sewers and other structures have proved moderately successful, given continued inspection and maintenance. The function of these linings is to isolate the concrete from the corrosive atmosphere. To be effective, the lining including joints, must be sealed completely to protect the sewer system throughout its expected life.

The interior of cast iron and ductile iron pipe usually is lined with cement mortar. Steel pipe sometimes is lined similarly. Smooth-walled steel pipe also may be protected by cementing plasticized polyvinyl chloride sheets to the pipe and sealing the joints.

Corrugated metal pipe may be coated inside and out with bituminous material. For added protection, asbestos fibres may be embedded in the molten zinc before it is bituminous coated (asbestos bonded). Such coatings should be of impermeable material of sufficient thickness and free of flaws such as pin holes.

22.2.5.2 PROTECTIVE COATINGS

Any protective coating used should possess the following qualities: (i) it should be resistant to acid attack, (ii) it should bond securely to the concrete, (iii) it should be economical and durable, (iv) it should be resistant to abrasive action by flow of sewage, and (v) when applied, it should be thin enough to fill all pores and irregularities in the surface. The coating should be continuous with no pin holes or other breaks.

The effectiveness of a coating thus depends on its inherent resistance to acid attack and also on its ability to form impervious membrane. In practice, no coating can be applied without discontinuity. Inspection and maintenance must be periodical. Plastic-base paints and coal tar epoxy coatings have

proved to be good.

22.2.5.3 CATHODIC PROTECTIONS

Cathodic protection is the application of electricity from an external power supply or the use of galvanic methods for combating electrochemical corrosion. Cathodic protection should be used as a supplement and not as an alternative technique to other methods of protection. It may be a more suitable and expeditious method of protection for existing pipelines.

a) *Basic Principle*

The basic principle is to make the entire surface of the equipment cathodic thus affording protection since corrosion takes place only at the anodic surface. This can be achieved by connecting it to a D.C. source. In this case, the anode consists of specially earthed electrodes. The general arrangement in a cathodic protection assembly is shown in the Figure 22.1.

The current from the positive pole of the D.C. source flows through the conductor 2 into the earthed anode 3 and then into the soil. From the soil the current flows to the surface of the pipe 4 to be protected and flows along the pipe to the drainage junction point 5, the conductor 6 and back to the negative terminal of the current source. Thus the entire surface of the underground pipe or equipment becomes cathodic and is protected from corrosion while the earthed anode gets corroded. The anode is usually scrap metal e.g. old tubes, rails etc. Other metals which are resistant to attack by surrounding soil like special alloys or graphite are also used. The conductivity of the protective coating has a direct influence on the length of the protected section of the pipe. The required power increases with increasing conductivity of the coating.

b) *Preliminary Investigations*

The existing pipeline has to be inspected to ascertain the sections which require protection. Other basic information required are

1. Plan and details of the pipelines (showing branch connections, diameter, length and wall thickness) and
2. Location plan of the section to be protected along with
 - i) data on soil resistance along the section to be protected at the intervals of at least 100 m as well as the earthing points
 - ii) information on the availability of sources of electricity, amperage, voltage, DC/AC (phase) in the vicinity and spaces for housing current supply and controls
 - iii) data on the conductivity or resistivity of the existing protective insulation ; and
 - iv) condition of the pipeline, if it is already in use.

c) *Power requirements*

With the above data, minimum current density and maximum protection potential can be worked out. The capacity of the current source for a cathodic protection system depends on (1) length of the section to be protected (2) type and state of the coating of the pipeline (3) diameter of the pipe (4) wall thickness of the pipe (5) conductivity of the soil and (6) design of anode earthing. The power requirements vary from 0.4 to 10 kilowatts in most cases. The possible current sources are D.C. Generator,

converter-rectifier, storage batteries of dry or acid type. The pipeline should be at least 0.3 V negative to the soil.

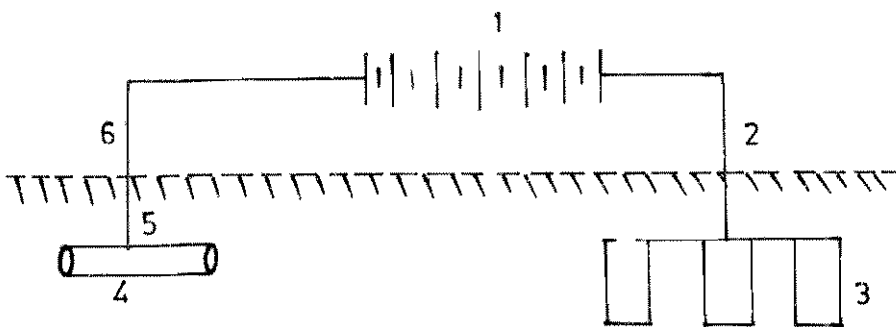

FIG.22.1 : GENERAL ARRANGEMENT OF CATHODIC PROTECTION

d) **Anodes**

The main power loss occurs in the anode earthing. The earthing can be carried out by any metal (pure or scrap) of any shape and also carbon forms like coke or graphite. When tubes are used the earthing can be either horizontal or vertical. Near the earthing zone, soil treatment can be done to reduce soil resistance by adding salts like sodium chloride, calcium chloride or moistening the soil, the former being better and long lasting. Carbon or graphite electrodes have longer durability than metal electrodes.

e) **Other facilities**

A cathodic protection station should provide space for housing the equipment, installation of current sources, supply and distribution zones, equipment for check measurements, construction of earthing structures and facilities for carrying out operational tests.

22.2.5.4 PROTECTION BY SACRIFICIAL ANODE

Sacrificial anodes serve the same purpose as the cathodic protection system but does not require external electric power supply. The required current is supplied by an artificial galvanic couple in which the parts to be protected, usually iron or steel, is made as the cathode by choosing the other metal having the higher galvanic potential, as the anode. Zinc, aluminium and magnesium (with sufficient purity) or their alloys which are higher up in the galvanic series must be used for this purpose. Sheets of zinc suspended in a coagulation basin is an example. A single protector anode will not be sufficient and it will be necessary to instal a number of such anodes generally spaced at 4 to 6 m in the pipeline or the structures to be protected.

The performance and service life of anodes depend mostly on the nature of soil or water surrounding them. Use of fill materials in the soil such as clay and gypsum powder results in low resistance of anode earthing and yields a high current. The costs of protection by galvanic anode would be appreciably higher in the case of pipeline networks in big towns since it would be necessary to suppress incidental contacts. For the application of galvanic protection the resistance of the soil should be less than 12,000 ohm-cm. A higher resistance of the circuit can neither achieve the required current density nor reduction of the pipe to soil potential. In such cases, cathodic protection by means of external power supply offers better protection.

The following measures are also of interest in minimising corrosion :

- i) Minimising point of high turbulence within the system thus resulting in less sulphide generation
- ii) Designing wet wells to preclude surcharge of tributary lines which also result in less sulphide generation
- iii) Provision of forced ventilation at a point where air may be depleted seriously of its oxygen
- iv) Using a coating of another metal such as Zinc (eg) Galvanised iron or using paints appropriately
- v) Gas Scrubbing
- vi) Providing inside sleeving or lining of suitable type of plastic materials.

The problem of sewer corrosion due to Hydrogen sulphide production and its control is a serious one to the waste conveyance system. Prevention of H_2S generation by proper design and continued cleaning of sewers seems to be the best available methods.

22.3 CORROSION OF TREATMENT SYSTEMS

A waste treatment plant generally consists of screen and grit removal units, primary and final settling tanks, sludge digestors, trickling filters or activated sludge treatment units and the various pumping units for pumping of raw sewage, settled sewage, digested sludge, etc. In case of certain industrial wastes acid or alkali neutralisation or preaeration may also be provided. The more important units from the corrosion point of view are the neutralisation tanks. Settling tanks, the digestors and the activated sludge units, in addition to all pumps, and appurtenances.

Screens and grit chamber equipment also need some consideration for corrosion prevention.

22.3.1 Neutralisation Tanks

Where acidic or alkaline wastes are received they may have to be held first in equalisation tanks to balance out fluctuations in quality and quantity, followed by neutralisation of the resultant acidic or alkaline waste as necessary. In such cases the equalisation as well as neutralisation tanks may have to be provided in RCC with acid resistant lining of tiles or bricks laid in acid resisting cement. The neutralising chemicals would need to be stored in acid or alkali resistant containers and the solutions led to the neutralizing tank by PVC piping.

22.3.2 Sedimentation Tanks

The primary sedimentation tanks handle raw waste which is allowed to settle at the bottom. The bottom of the settling tank is scraped by mechanical scraper in order to divert the sludge to a point from where it is withdrawn either continuously or periodically. The scraper arms and the squeegees are constantly immersed in sewage and are subjected to corrosion. Moreover, sewage and most industrial wastes have much lower resistivity than water, which account for rapid corrosion. The specification for the steel used for the under water mechanisms should be carefully drawn to ensure maximum protection from corrosion. It is normally specified that all the steel below liquid level shall be at least 6 mm thick. It is a good practice to keep all chains, bearings or brackets above the liquid surface. All castings in the driving mechanism should be of high grade cast iron.

It is possible to give cathodic protection to the scraper mechanism of the clarifier either by sacrificial anode or by impressed current. The choice of either of the method of cathodic protection will depend upon the comparative costs. In any case, the cost of such a protective measure will not be higher than the cost of good quality acid resistant paint.

22.3.3 Sludge Digestion

In sludge digestion tank, digestion of sludge is carried out under anaerobic conditions for a long period. During the normal functioning of the digester and more so during faulty operations, various acids are produced, for a temporary period. The waste may contain appreciable quantity of sulphates due to seepage of sea water in coastal regions or due to industrial wastes. Under anaerobic conditions in digester the sulphate will be converted to hydrogen sulphide. The corrosion due to hydrogen sulphide is in fact due to sulphuric acid formed in presence of moisture. This will attack the digester walls and also the mechanical equipment to such an extent that breakdown may occur ultimately. Cement resistant to attack by H_2S , such as blast furnace slag cement, should be used in the construction of digesters.

It is observed that the draft tubes inside the digester are sometimes provided of mild steel. This is not a good practice since the life of such metallic tubes in the highly corrosive interior will be very limited. Hume or concrete pipes of thicker cross section are therefore recommended for use as draft tubes. Use of guy ropes inside the digesters should also be discouraged. Screw pumps are provided in the digester for proper circulation of the tank contents. The blades of this screw pump should be of corrosion resistant materials. In many installations the sludge gas is collected and burnt or utilised for other purposes. If the gas contains H_2S , this will be very corrosive under moist conditions to the gas engines, gas meters and all the equipment and piping. It is therefore necessary to remove H_2S by scrubbing in such cases.

22.3.4 Activated Sludge

In the activated sludge plant oxygen is provided to the sewage either by compressed air system or by surface aeration system. In the compressed aeration system the clogging of porous filter material is of frequent occurrence. Clogging can be either on the liquid side or on air side or on both the sides. Clogging on the liquid side can be minimised only by the use of air supply pipelines of noncorrosive material. It is, therefore, important to have the air supply pipelines of non-corrosive material.

In surface aeration, the simplex types of aerators are more widely used in India. The conditions in the aeration tank are more conducive to corrosion since in addition to the corrosiveness of the liquid, oxygen is present to aggravate the situation. Proper material selection and coating are therefore necessary for protection of the exposed parts of the rotor. It may be mentioned here that the protective coating has to be applied at regular intervals since it is found that such coatings have very short life. PVC lining may not be easy to provide due to the shape of rotor while fibreglass lining can be adopted to any irregular shape.

Floating Aerators : For floating aerators, it is desirable to have corrosion resistant lining, such as of fibreglass, for the floats.

22.3.5 Trickling Filters

In trickling filter the mechanical components include the header, the distribution arm and the distribution nozzles. The header and the distribution arm are normally of mild steel and should be protected from corrosion by proper painting. The corrosion and the resulting blockage of distribution nozzles are of common occurrence. This can be avoided by selection of proper corrosion resistant materials such as brass or PVC for nozzles.

22.3.6 Sewage and waste water pumps

For pumps and pumping equipment, proper materials selection is of paramount importance. The pump casing is normally of close grained cast iron capable of resisting erosion on account of abrasive material in the waste. For handling sewage and other corrosive wastes, the impeller is generally made of high grade phosphor bronze or equivalent materials. The wearing rings for impeller should be of good corrosion resistant materials such as bronze. The shafts are normally made of high tensile steel and replaceable shaft sleeves are recommended.

For pump and pumping equipment, painting is the usual protective measure. Both the interior and exterior surfaces of pumps should be painted after rust scale and deposits are removed by sand blasting, wire brushing or rubbing with sand paper.

22.3.7 Preventive Maintenance

It will be seen from the above that anti-corrosive paints, coating and linings have to be used in various equipment to prevent corrosion. The paints, coatings and linings require periodical renewal. Proper maintenance demands that a schedule be drawn up so that the operator may abide by it and undertake repainting or cleaning at appropriate intervals without waiting for corrosion to become obvious.

22.3.8 Piping Requirements in Treatment Plants

Piping requirement in wastewater treatment plants range from wastewater and sludge conduits, drains and water lines to chemical process piping, if any. Construction materials for various pipe line applications are given in Table 22.2.

TABLE 22.2
PIPING MATERIALS

Typical Application	Concentration %	Materials
Influent	0.5 to 2	C, CI, RCP, RC, VC
Secondary Solids	0.5 to 2	C,P,CI
Primary solids	0.2 to 1	C,G,T,P,D,CI
Thickened Sludge	4 to 10	C,P,T,CI D
Digested Sludge	3 to 10	C,P,T,CI
Chemically treated sludge	8 to 25	C,P,H,CI
Dewatered sludge	8 to 25	C,CI
Heat Exchanger	< 0.1	S,
Spray Irrigation	< 0.1	C,CI T,A,P
Chemical Process Piping		C,CI,S,G,T,P,H,D
Aluminum Sulphate	15 to 22	C,D,H,P,T,S
Calcium Hydroxide	63 to 73	C,CI,D,G,H,P,S,T
Calcium Hydroxide	85 to 99	C,CI,D,G,H,P,S,T
Sulphuric Acid	93	S,G,
Ferric Chloride	59 to 98	C,H
Sodium Hydroxide	73	C,S,H
Carbon Slurry	20 to 30	G

Note: * As percent total solids unless otherwise indicated.

C - Carbon Steel
S - Stainless Steel
G - Glass Lined
A - Aluminium
T - Teflon lined
P - Plastic
CI - Cast Iron
D - Ductile iron
H - Plastic or rubber hose
RCP- Reinforced Plastic mortar
RC - Reinforced concrete
VC - Vitrified clay

22.3.9 Modification of Materials

Normally, the materials that are most suitable under circumstances likely to be encountered should be used commensurate with economy. If justified economically, corrosion resistant construction material can be used initially which may not require any additional protective coating frequently. Stainless steel, aluminium and plastics are examples of materials of this nature. It is possible that the use of such corrosion-resistant materials would be cost-effective in the long run. However, in treatment plants, it is found that it is usually less expensive to use ordinary structural steel to which protective coatings are applied.

CHAPTER 23

TREATMENT PLANT OPERATION AND MAINTENANCE

23.1 INTRODUCTION

Maintenance comprises those operations which are well planned systematic programme of maintaining the machinery by taking appropriate steps to prevent breakdown well in advance before it causes major damage. This prevents wastage of time, production loss and prolongs the life of machine. This maintains better efficiency in the system and economises the running cost of the plant. It can be classified as (a) preventive maintenance which constitutes works and precautions to be taken to prevent breakdown and (b) corrective maintenance which involves carrying out repairs after breakdown. Preventive maintenance is more economical than corrective maintenance and provides uninterrupted service which is essential to achieve the basic objectives of treatment, viz protection of health of the community and prevention of nuisance.

Proper maintenance does not start at repairs and maintenance but starts right at the time of planning, selection and the installation of the machinery. In fact much of the preparation starts at the planning stage itself. If due care is not taken in properly forming specification and selection, then it results in poor performance and frequent damage to the machinery. Wrong selection of the material of the parts also leads to frequent breakdowns. Hence, the concept of preventive maintenance should be the basis of all thinking involved in the evaluation of the plant right from planning preparation of specifications, procurement, preparation of layout of the plant installation and finally routine maintenance.

The primary aim of sewage treatment plant operation is the running and maintenance of the plant, efficiently and economically so that the effluent from the plant meet the prescribed standards in terms of BOD/COD/SS/pH etc., laid down by the local body or any other statutory body while discharging the effluent safely in public sewer, on land or in the water body.

The basic requirements of successful operation and maintenance of sewage treatment plants are:

- i) a thorough knowledge of plant and machinery and equipments provided in the treatment plant and their functions
- ii) a thorough knowledge of the processes
- iii) proper and adequate tools
- iv) adequate stock of spare parts and chemicals
- v) assignment of specific maintenance responsibilities to operating staff
- vi) systematic and periodic inspection and strict adherence to servicing schedules
- vii) training of all operating staff in proper operating procedures and maintenance practices
- viii) overall supervision of operation and maintenance schedules
- ix) good house keeping

- x) proper logging of all operation / maintenance activities
- xi) observation of safety precautions & procedures.
- xii) provision for water supply for drinking and other uses.

The various units of the plant are designed for maximum efficiency within a certain flow range and sewage quality. Close control and co-ordination of operation of different units are therefore, required within the limits of design so as to achieve maximum efficiency. Hence, accurate measurements of flow of raw and settled sewage, air, recirculated sludge/effluent, sludges and final effluent are required. For this purpose flow measuring devices and meters, preferably of the indicating and recording types, are provided to guide the operator in his supervision and obtain data for progressive improvement. For quality control, analysis of sewage, sludges, digested sludges, gas composition and volume etc., as they pass through different units of the treatment plant and of the effluent should be carried out on a regular basis as prescribed in Chapter 24. Proper recording of data is essential for an accurate assessment of efficiency of operation. On the chemical side, dosages must be closely and accurately proportioned to the varying rates of flow of sewage and sludge based on analysis.

Better plant operation is possible only when the operating maintenance and laboratory staff are fully conversant with the characteristics and composition of sewage handled and the results achieved during each state or unit of the treatment process.

Operation and preventive maintenance of several treatment units and the frequency of cleaning, lubrication of mechanical equipments etc., are to be strictly adhered to if optimum results are to be expected.

23.2 TREATMENT UNITS

23.2.1 Screens

Hand cleaned screens should be cleaned as often as required to prevent backing up of sewage.

Mechanical screens should be kept properly lubricated as per instructions of the manufacturers. The entire mechanism should be thoroughly cleaned and painted with two coats of appropriate anticorrosive paint at least once in a year. Slack in chains should be promptly rectified. Periodic inspection of mechanical and automatic screens is essential to ensure that the equipment is functioning properly.

Screen chambers should be nosed, at least once a day to keep them clean and the walls should be scrubbed at least once a week. It should be ensured that the side guide channels are properly positioned and secured in their original position.

Prompt and hygienic disposal of screenings is necessary. Mechanical screens may discharge screenings into wheel barrows or containers. Burial is the most common method of disposal. Composting with city refuse, trenching under earth cover and incineration can also be adopted. Where shredders are used, screenings should be washed to remove grit to prevent wearing of the cutting edges of shredders.

Daily record of operations should be maintained to show frequency of cleaning, volume of wet screenings removed and power consumption for mechanically operated screens. Besides, record should also be made of time settings between strokes for mechanically operated screens.

23.2.2 Grit Chamber

The frequency of grit removal should be adjusted such that the storage space is not more than about half full at any time. Cleaning of grit chamber becomes essential after a heavy storm particularly when sewage is received from a combined sewerage system.

In manual cleaning, the flow is shut off, the chamber emptied by gravity or pumping and the grit hauled by using long handled shovels, buckets and wheel barrows. The operator must always use gumboots and hand gloves.

Inspection of mechanically cleaned grit chambers consists of checking of washed grit, lubrication of mechanical equipments as per manufacturer's schedule and routine inspection.

Grit should be disposed off safely at predetermined disposal sites, providing adequate earth cover.

The record of operation should show the dates of cleaning, amount of grit removed and flow through the chamber between cleanings.

23.2.3 Sedimentation Tanks

23.2.3.1 SLUDGE

Sludge removal should be sufficiently frequent to avoid development of septic conditions. Sludge is removed continuously in some plants and 2 to 4 times a day in others.

Sludge from the primary sedimentation tanks is drawn from the sludge sump by means of a pump discharging into digesters, sludge from secondary settling tanks is pumped partially to aeration tanks and partially to primary sedimentation tanks. While drawing the sludge, the operator should take samples and adjust the pumping capacity according to quantities required for feeding the digester or returned to aeration or primary sedimentation tanks. Excessive sludge pumping and withdrawal of watery sludge should be avoided. When the sludge is drawn by hydrostatic pressure, the valve on the pipe is opened partly and the sludge allowed to flow out. When the sludge becomes thin the valve should be closed. Most plants utilizing this method are so designed that the operator can see the sludge as it is being drawn and judge when the valve should be closed.

In sedimentation tanks provided with mechanical sludge scrapers, sludge may be withdrawn continuously or at predetermined intervals. If automatic starting and stoppage of pumps is involved, the setting of this equipment should be periodically checked.

23.2.3.2 BULKING AND RISING OF SLUDGE

The quick settleability of sludge is an important factor in the efficient performance of the activated sludge plant. The SVI serves also as an index of sludge settleability. SVI values of 80-150 are considered satisfactory in plants operating with MLSS of 800-3500 mg/l. Sludge with poor settling characteristics is termed bulking sludge. Sludge bulking results in poor effluent due to the presence of excessive suspended solids and also in rapid loss of MLSS from aeration tank. Sludge bulking is generally due to inadequate air supply, low pH or septicity and also due to growth of filamentous organisms consequent to the presence of industrial wastes containing high concentration of carbohydrates in sewage. Sludge bulking is controlled by eliminating the causes and by application of chlorine either to the sewage or to the return sludge to control filamentous growths. Chlorine requirements are 0.2 to 1.0 percent of dry solids weight in return sludge.

For proper control of anaerobic digestion process three parameters namely pH, alkalinity and volatile acids should be regularly monitored. Digestion proceeds favourably at pH values of 7.0 to 7.6, preferably above 7.2 and the ratio of volatile acids to alkalinity should be kept less than 0.5. If the digester turns sour, lime is usually added to correct the pH to the desirable range. The lime can be added at the sludge pump or in the recirculation pump as recirculation is helpful in bringing about mixing.

When sludge bulking occurs, the suggested remedies are: (i) reduction in rate of sewage flow into aeration tanks; (ii) reduction in ratio of return sludge; (iii) increase in air supply or (iv) dilution of incoming sewage. Chemicals that may be used to reduce bulking include chlorine, lime (raising pH to 8.6 to 8.8) or chlorinated coppers etc. These are added to the return sludge in small doses to ensure that they do not become toxic to micro-organisms.

23.2.3.3 SKIMMINGS

Floating materials collecting on the surface of primary sedimentation tanks are removed by skimming devices operated mechanically. Where such mechanical skimmers are not provided, manual removal at least once a day is recommended. In mechanical skimming devices the skimmer brush tips the scum into a scum trough discharging into a sludge sump, from where it is pumped along with the sludge. The skimmer device should be inspected periodically and moving parts lubricated.

23.2.3.4 STRUCTURES AND MECHANICAL EQUIPMENTS

The side walls of the settling tanks should be so finished as to minimise the collection of solids, grease, oil and aquatic growths. Collections, if any should be removed periodically by brushing and hosing them down without disturbing the tank contents. Dark floating matter and rising bubbles on the surface indicate improper cleaning and inadequate sludge removal.

Inlet and outlet channels should be kept clean and hosed at least once a week. All baffles should be cleaned of any sticky materials and stringy growths on the surface and edges.

The bearings, transmission gears, traction rollers, etc.. should all be properly lubricated as per the lubricating schedule suggested by the manufacturer. (Table to be prepared to show the records to be maintained daily, weekly, monthly etc for various parameters).

In addition, it is good practice to dewater each clarifier at least once a year to inspect the submerged portions of the mechanism such as flight scrapers, squeezes etc. repair or replace the wornout parts, check all nuts and bolts for tightness and repaint all metallic parts. Motors should be checked periodically for overload conditions and electric wirings for proper insulation. Where cathodic protection devices using impressed current are provided, the strength of protective current should be checked.

23.2.3.5 RECORDS

The daily operation records should show frequency and method of cleaning, flow, flow through time, volume of sludge and scum removed and percentage moisture in sludge, settleable solids both in sewage and in effluent from sedimentation tanks. The suspended solids, BOD of both influent and effluent should be recorded as per Appendix 24.2.

23.2.4 Aeration Tanks

The operational variables in an activated sludge plant include rate of flow of sewage, air supply, MLSS, aeration period, DO in aeration and settling tanks, rate of sludge return and sludge condition. The operator should possess a thorough knowledge of the type of system adopted viz. conventional, high rate,

extended aeration or contact stabilisation so that effective control of the variables can be exercised to achieve the desired efficiency of the plant. Inspection of mechanical aerators should be done for bearings, bushes, transmission gears, and they should be lubricated as per the schedule suggested by the manufacturers. The whole unit should be thoroughly inspected once in a year including replacement of worn out parts and painting with anti-corrosive paint to achieve desired efficiency of the plant. The record of operation should be maintained.

23.2.4.1 SEWAGE FLOW

Since the activated sludge treatment is biochemical in nature, conditions in the aeration tank should be maintained uniform at all times. Sudden increase in the rate of flow or slugs of flow should be avoided. Supernatants from digester containing more than 3000 mg/l. of SS if taken into the settling tank, should be pretreated as otherwise heavy load will be imposed on the activated sludge system. Measurements of sewage flow and the BOD applied to the aeration tank should be made.

23.2.4.2 AIR SUPPLY

Frequent checks of DO at various points in the tank and at the outlet end which should not be less than 1 mg/l will help in determining the adequacy of the air supply. The uniformity of air distribution can be easily checked by observing bubbling of the air at the surface, which should be even over the entire surface area of the tank. If the bubbling looks uneven, clogging of diffusers if indicated. Clogging is also confirmed by the increase of 0.1 to 0.15 kg/cm² in the pressure gauge reading. Adding chlorine gas to air may help in removing clogging of diffusers on air side if it is due to organic matter. Other methods of cleaning will have to be resorted to, if this procedure does not clear up the clogging. Air flow meters should be checked periodically for accuracy and hourly and daily air supply and air pressures should be recorded to avoid over-aeration or under-aeration. Mechanical or surface aerators should be kept free from fungus or algal growths by cleaning them periodically.

23.2.4.3 MIXED LIQUOR SUSPENDED SOLIDS

Control of the concentration of solids in the mixed liquor of the aeration tank is an important operating factor. It is most desirable to hold the MLSS constant, at the suggested rates. The test of MLSS should be done at least once a day on large plants, preferably during peak flow. As the MLSS will be minimum when the peak flow starts coming in and will be maximum in the night hours when the flow drops, operating MLSS value would be the average hourly value in a day which should be verified at least once a month. In case of very large plants regular daily check is desirable.

23.2.4.4 RETURN SLUDGE

The return sludge pumps provided in multiple units should be operated according to the increase or decrease in return sludge rate of flow required to maintain the necessary MLSS in aeration unit, based on the sludge volume index. The sludge volume index should be determined daily to know the condition of the sludge. A value of over 200 definitely indicates sludge bulking.

A good operation calls for prompt removal of excess sludge from the secondary tanks to ensure that the sludge is fully aerobic. This should be measured daily and recorded. The excess sludge is taken to digester directly or through primary settling tank.

23.2.4.5 FOAMING

Foaming or frothing is sometimes encountered in activated sludges plants when the sewage contain materials which reduce the surface tension, the synthetic detergents being the major offender. Froth,

besides being unsightly, is easily blown away by wind and contaminates all the surfaces it comes into contact with. It is a hazard to workmen because it creates a slippery surface even after it collapses. Foam problems can be overcome by the application of a spray of screened effluent or clear water, increasing MLSS concentration, decreasing air supply or addition of other special anti-foam agents. The presence of synthetic anionic detergents in sewage also interferes with the oxygen transfer and hence reduces aeration efficiency.

23.2.4.6 MICROSCOPIC EXAMINATION

Routine microscopic examination of solids in aeration tank and return sludge to identify the biological flora and fauna present will enable good biological control of the aeration tanks.

23.2.4.7 RECORDS

Activated sludge operation should include recording of flow rates of sewage and return sludge, DO, MLSS and Biota, sludge age, air, BOD, COD and nitrates in both influent and effluent.

23.2.5 Trickling Filters

23.2.5.1 DISTRIBUTORS

All clogged spray nozzles or orifices in the revolving distributors should be cleaned as soon as clogging is noticed. Dosing tanks should be kept free from accumulation of deposits. Placing of fine screens in the discharge channel of the sedimentation tank prevents the entry of coarse solid into the filter.

All parts of the filter bed should receive equal loading which should be tested periodically by using watertight pans of standard size 90 cm x 120 cm, set flush with the top of filter media, end to end, along the radius. The media surface shall be divided into two concentric circles with the area of the inner being 10% of the total area covered by the distributor. The sewage collection in the pan for 10 revolutions of the distributor when the air is still, is measured. The rate of distribution should not vary more than $\pm 5\%$ from the mean rate of distribution in the outer 90% area and $\pm 10\%$ in the inner 10% area.

Rotary distributor should be inspected daily for the purpose of keeping all nozzles clean and in operating condition keeping the arm level by adjusting turn buckles on the guy rods or cables and keeping the guide rollers in proper adjustment. It is advisable to take out each rotary distributor once a year to paint all surfaces with an anticorrosive paint.

In cold climates, spray nozzles should be kept free from freezing by opening the drain valve in the terminal end of the distribution system. Where dosing tanks with siphons are installed, adequate head should be maintained in dosing tanks. Siphons should be checked for air leaks. Grease and solids accumulate in the dosing tank during high water level and pass into the siphon and clog nozzles. Hence, periodic cleaning of dosing tanks is necessary.

23.2.5.2 PONDING

Pools or ponds sometimes form on the surface of the filter. This is due to organic growth or retained organic matter from poorly settled sewage. Sometimes, this is due to careless dumping of fine material in one place at the time of placing media in the filter box. In many cases the trouble lies in the top layer of the media and forking or raking the media to a depth of 20 to 30 cm. will effectively remove ponding. Washing the filter for 2 to 3 days may also be effective. Prechlorination of sewage or application of caustic soda upto 10 mg/l. has also been tried with success to eliminate clogging and ponding problems. When using chemicals, treatment may be given for 8 hour periods on alternate days.

23.2.5.3 UNDERDRAINS

Filter underdrains should be inspected frequently for clogging. If clogging is evidenced by reduced flow from any drain, this should be flushed and cleaned with sewer rods.

23.2.5.4 ODOUR

Odours from septic sewage must be controlled by eliminating the causes before sewage reaches the spray nozzles, prechlorination being effective in controlling odour.

23.2.5.5 FILTER FLIES

Psychoda filter flies sometimes infest the filters and cause not only nuisance to the workers but also clog the beds. Flooding the bed for 24 hrs. at intervals of 9 to 10 days, application of chlorine at a rate of 3 to 5 mg/l. or use of permitted insecticide once a week are the methods available for destroying the larvae. Adult flies are controlled by pyrethrum spray. Allowing the bed to dry is not a good practice as it will inactivate the microorganisms.

23.2.5.6 RECORDS

Operating records should show the units of filter in service each day, the number of nozzles cleaned, the dates of cleaning the distributors and underdrains and the rates at which the filters were operated. In the case of high rate filters, recirculation pumps should be operated according to the time schedule. Quantity recirculated and hours of recirculation should be properly recorded. Dates on which measures were taken for correction of ponding and psychoda fly control should also be recorded and prominently displayed on structure.

23.2.6 Sludge Digestion Tanks

Sludge should be added according to a set schedule preferably spread over as long a period as possible. Sludge withdrawal should not be excessive since this may lead to retardation of digestion.

23.2.6.1 DIGESTER OPERATION

For start up, digester tanks with fixed covers should be filled initially with water, sludge or sewage to expel air. In tanks with floating cover, the cover should be brought down to the lowest point before filling of the tank is commenced. In order to reduce initial lag period, raw sludge mixed with digested sludge in the ratio of 2:1 to 4:1 may be pumped to the digester so that alkaline digestion starts within a few days after loading. The addition of fresh sludge should commence only after this stage. If digested sludge is not available raw sludge mixed with cow dung is pumped and kept for 2 to 3 weeks before the digester can be loaded. Open digesters can be charged directly.

The raw sludge feeding rate should be such that the volatile solids in the digester should not exceed 3 to 5% so that digestion is not inhibited. Generally a loading rate of 1 to 2 Kg of fresh solids to every 40 to 50 Kg. of digesting volatile solids should be the ratio to maintain a uniform digestion rate.

The Digester tank shall be provided with electric motor on the top with reduction gear box. Vertical stainless steel shaft shall be fitted with screw pump. All these machinery shall be robust and capable of withstanding the effect of gas generated and corrosion. In addition to above, one safety valve to release excess pressure, test cock and manhole shall be provided to the Digester tank. Wherever electric heaters are provided, the heating elements shall be able to withstand corrosion, effect of methane gas and other gases generated in the Digester Tank.

Where digesters are equipped with mixing devices, they should be operated in accordance with the manufacturer's instructions and if necessary same should be rotated in reverse direction to have better mixing sludge. Where facilities for recirculation by pumping exists, they should be used for mixing digester contents, breaking down scum, mixing lime with sludge for pH adjustment etc. Where there is no mixing and recirculation facility, the operator has to rely upon natural mixing of raw and digested sludge in the digestion unit.

Where heating arrangements are provided in the digester, the temperature of the hot water pumped through should not be above 55°C to prevent sludge caking on the outer surface of coils causing loss in heat transfer efficiency. Digestion is generally carried out in the mesophilic range and the temperature of sludge generally varies from 20°C to 40°C. Thermometers to record temperature of sludge should be kept in order and reading noted twice or thrice a day.

Sludge should be withdrawn from the digester only when it is fully digested, judged by the dark greyish colour without visible raw sewage sludge solids. Sludge should be sampled and tested to find out the condition before withdrawing. Generally not more than 10% of the capacity of digester should be drawn at a time, sludge withdrawn being limited by the capacity of the sludge drying beds.

Difficulties in the digestion tanks such as foaming due to overloading or accumulation of acid sludge or excessive formation of H_2S have to be corrected by neutralization and adjustment of pH. H_2S in moist gas leads to corrosion of meters, piping and flame trap through which the digester gas is drawn. This can be overcome by the removal of the H_2S by passing the gas through ferric salts or scrubber. Where digester is utilised for heating digester or operating gas engines etc., equipment supplied for handling the gas should be installed and operated strictly according to manufacturer's instructions. As the gas is highly explosive, ordinary plumbers should not be engaged in correcting any defects in the gas collection system consisting of flame trap, drip trap, pressure relief valve etc., Copper tools should be used so that no spark is created.

Gas pipes should be kept free from sediments, gas meter being periodically lubricated and fusible plugs in the flame traps frequently checked.

If the pumping of the supernatant liquor, having very high BOD and SS, into sedimentation tank adversely affects it, the liquor may be treated on sand beds or discharged separately.

23.2.6.2 RECORDS

Records of the pump capacity and the pumping hours of the sludge from settling tanks to the digester should be maintained. The alkalinity and pH values of sludges should be recorded daily. The dates of withdrawal of sludge, amount drawn, amount of sludge loaded on drying beds and the depth of loading should be recorded. Records of daily estimation of percent dry solids in the raw sludge, total and volatile solids in the digesting and digested sludges, volatile acids in the digesting sludge and BOD and SS of supernatant should also be maintained. Records of the gas production as measured through gas meters and weekly records of production as measured through gas meters and weekly records of gas analysis for percentage composition of methane should be maintained particularly where gas is utilised to produce energy.

23.2.7 Sludge Drying Beds

Sludge that is drawn to the beds contains 4-10% solids depending upon the type of sludge.

Wet sludge should be applied to the beds to a depth of 20 to 30 cm. After each layer of dried sludge has been removed the bed should be raked and levelled. Sludge should never be discharged on

a bed containing dried or partially dried sludge. It is preferable to apply the sludge at least a day or two after the sludge cakes are removed.

Removal of dried sludge from bed surfaces should be done with shovel, taking care that as little as possible of the sand is removed. When the sand layer is reduced to as low as 10 to 15 cm, it should be examined for clogging by organic matter and if found so, the entire sand should be removed and the bed resanded to the original depth of 20 to 30 cm.

The dried sludge cakes may be sold as fertilizer. Some part of the sludge should be used in the plant itself for gardening, lawns, etc., to demonstrate its fertilizer value and to develop a market value for the digested and dried sludge. Suitable storage facilities may be provided for the dried sludge.

Records of operation of sludge drying beds should show the time and quantity of sludge drawn to each bed, the depth of loading, the depth of sludge after drying time and the quantity of dried sludge removed. The solids content of wet digested sludge, its volatile portion and pH should be determined and recorded. Likewise the moisture content and fertilizer value in terms of NPK of dried sludge should also be analysed and recorded.

23.2.8 Stabilization Ponds

As stabilization ponds require comparatively less operation and maintenance, they are often neglected with the result that several failures have been reported. Hence, proper supervision and good housekeeping are needed to ensure that the ponds are well maintained and the expected performance is attained.

23.2.8.1 OPERATION AND MAINTENANCE OF FACULTATIVE POND

Before the pond is put into operation the bottom is cleared of vegetation and debris. Raw sewage is then admitted to stand to a depth of 15 to 30 cm., small quantities of sewage being added each day to maintain this depth till algae establishes itself naturally in a week or two. After ensuring the establishment of algae, the pond is gradually loaded to raise the water level by 15 cm. each day till the entire pond is filled. The pond is then given rest for 2 to 3 days to ensure optimum growth of algae before loading the pond for continuous operation at the designed flow.

Ponds treating industrial wastes or a combination of sewage and industrial waste, may need acclimatization of algal species and addition of nutrients if found deficient.

The bunds should be inspected for the condition of the berms for any burrows by rodents, condition of pitching and erosion due to wind, wave action and rain. Any defects noticed should be promptly set right.

Ponds should be inspected for characteristic changes in colour and odour. A change in colour or odour in all probability forecasts major change in the performance of the pond system. Odour may be caused by the setting in the anaerobic conditions or entry of industrial waste or overloading. Colour changes may be caused by change in volume of inflows, organic loads, temperature, transparency of liquid or light intensity. An aerobic or facultative pond functioning properly will look green on the surface. If the colour changes from green to black accompanied by floating matter, it may be due to too rapid fermentation of bottom sludge, frequent changes in characteristics of incoming waste or over loading. If the ponds turn deep red an invasion by sulphur bacteria is indicated and the sulphate contents of the incoming waste should be controlled.

Overloading of ponds leads to anaerobic conditions. When a pond becomes anaerobic due to overloading, measures should be taken to rectify it immediately by adding sodium nitrate, supplement oxygen, agitating the surface, recirculating the pond effluent or bypassing a portion of the flow.

The pond should be regularly cleared of floating mats of algae at the corners and sides. All marginal growth of weeds and vegetation should be removed by suitable implements. Herbicides should be used only when the growth is unwieldy and cannot be effectively cleared by manual or mechanical means. The overgrown and dead grass on slopes should be periodically cut and removed.

Access roads, fencing etc. should be inspected regularly and repairs, if needed should be attended to promptly.

Maximum average and minimum daily flows into the pond over the weir of parshall flume installed at the entry to the ponds are measured and recorded periodically.

In small installations, where there is no facility for analysis, samples of influent and effluent should be collected at least once a month or when the pond condition appears to deteriorate visibly and get analysed at the nearest laboratory.

In large plants, where a laboratory is always attached, daily analysis should be carried out. The tests to be conducted may include all or a few of the following depending on the nature of the waste, size of the plant and the quality of effluent required: (1) BOD, COD, MPN of coliform organisms total suspended and volatile solids for both influent and effluent; (2) diurnal variation of pH and DO in the pond; (3) Total organic nitrogen, ammonia nitrates and phosphates of effluent if used as irrigants and (4) on anaerobic ponds, oxidation reduction potentials (ORP).

Mosquito breeding in the pond should be prevented by removing all weed growth and marginal vegetation, using larvicidal measures only as a last resort. Seeding the pond with sufficient number of water minnows, such as gambusia which feed on larvae and eggs of mosquitoes may keep the mosquito population under control.

Fly breeding may be another problem in badly maintained ponds. Good house keeping and proper operation is essential to avoid fly breeding. Floating matter and scum should be removed daily, or broken down and drowned by a water spray.

In general, a well maintained pond with clean surroundings, free of waster collections, debris, etc., and a little bit of gardening and landscaping will present an aesthetic sight

23.2.8.2 RECORDS

Operation records should include daily inflow rates, daily or weekly or monthly analysis of influent & effluent, diurnal variation of the temperature, pH and DO in the ponds, dates and nature of maintenance repairs, dates of clearing of weeds, vegetation etc., as per Appendix 24.2.

23.3 BUILDING AND EQUIPMENT

23.3.1 Building and other Structures

Office building and structures should be well ventilated and illuminated. They should be maintained and kept in good repair, white or colour washed, metallic parts being painted annually. The effect of corrosive gases like H₂S could be minimised by proper ventilation, proper collection and disposal of corrosive gases and painting the structures which are prone to be attacked by the gas, with anticorrosive

paints. Dampness inside buildings could be reduced by proper ventilation. Wherever necessary exhaust fans and forced ventilation should be adopted.

23.3.2 Equipments

The operator should maintain a book of catalogues supplied by manufacturers containing instruction sheets of all equipments. In addition, printed or written operating and maintenance schedules should be displayed near each equipment in the language understood by all operating staff.

Lubricating schedules, cleaning and painting schedules, checks for efficiency, leaks and wear and tear and testing of safety devices, should be followed strictly according to manufacturers' instructions.

All metering devices such as weirs and float gauges should be maintained in proper working condition including calibration. Charts should be changed at the same hour every day. Records maintained should show total maximum and minimum rates of flow.

Operating, lubricating and maintenance instructions for all pumps and other mechanical equipment should be strictly followed. Special attention should be given to maintaining pumps in an efficient operating condition, free from clogging, excessive friction or entrance losses and abnormal power consumption due to wear and tear.

Water level in the wet wells should not be lower than the minimum designed level and all accumulations of grease and other deposits removed promptly.

Floats and sequence switches controlling the pumping cycles should be examined at the beginning of each shift. All pumps including standby pumps should be operated in rotation so that the wear and tear is distributed evenly.

All bearings, motors and electrical control equipment should be inspected daily for any overheating. The manufacturers' directions for operation and lubrication should be strictly followed. Packing glands should be checked for overtightening.

When pumps may have to be operated manually time interval between start & stop, should not be less than 5 minutes. A reversing switch shall be installed for dislodging the clogging materials. This can also be achieved by taking the backflow from the header main.

Chlorination equipments should be properly housed and reserve supply of cylinders, valves, gaskets etc. should always be available. Valves and pipings should be regularly checked for leaks. Leaks should be attended to as per the instruction in the manufacturers' catalogues. Chlorine cylinders should be kept on scales and the weight read each day as a check for the amount of chlorine used. Gas masks must be used while attending to chlorine leaks. Operation record should show the volume of sewage chlorinated, rate of application of chlorine, residual chlorine in the plant effluent and the amount of chlorine consumed each day. In case of severe chlorine leakage, arrangement should be provided for dumping chlorine cylinder in lime tank to nullify its effect in the atmosphere.

23.4 SAFETY IN THE PLANT

The work of an operator in a sewage treatment plant presents many hazards that must be guarded against. Common type of accident are injuries from falls, deaths from drowning and asphyxiation. Narrow walks or steps over tanks (particularly in darkness, rains and wind), ladder and spiral staircases are potential danger spots where the operator should be alert; overexertion during operation of valves, moving weights and performing other arduous tasks should be avoided. All open tanks should be provided with

guard rails to prevent accidental falls. Glass parts as well as moving parts should be protected by screen or guards. Adequate lighting within the plant and around the plant should be provided which gives better working facility reducing accidents on account of slipping etc. Honeycomb grating be provided on open channels to avoid accidents on account of falling down or drowning. The staff should be trained and compelled to use helmets, gumboots, hand gloves etc. Wherever necessary, precautionary boards/ danger boards / sign boards should be displayed in the plant wherever necessary, drawing attention to the potential danger spots.

Gas poisoning, asphyxiation and gas explosion are other hazards. Hence smoking or carrying open flames in and around digesters should be prohibited. Covered tanks, wet wells or pits should be well ventilated. Before entering, they should be kept open for sufficient time or preferably forced ventilated as they present problems of asphyxiation. Entry into them should be permitted only after ensuring the safety, by testing for the presence of hazardous gases (Appendix 8.1).

Gas masks should be stored in location where no possibility of contamination by gas exists and should be easily accessible. A first aid kit should be available readily at hand. Fire extinguishers of the proper type should be located at strategic points and maintained in good operating condition at all times by testing them. All staff should be trained in rendering first aid and operating fire extinguishing equipments.

Adequate number of toilets and bathing facilities, drinking water facilities and locker should be provided for the convenience of operating staff and protection from risk of infection. Eating facilities and canteen should be maintained hygienically.

All workers should be compelled to observe personal hygiene such as washing with soap after work as well as washing before taking food. The use of antiseptics along with washing should be emphasized. The employees should be medically checked after every six months specially for eye sight, hearing, indigestion, mental capability, T.B., Diabities, heart troubles etc.

23.5 TRAINING OF PERSONNEL

All operating staff engaged in technical and skilled work should be trained. Large plants should be headed by a plant superintendent who should have the necessary academic training in Public Health Engineering with considerable experience in sewage treatment. Other plants must be placed in charge of superintendent who should be an Engineer with orientation in Public Health Engineering and experience in operation and maintenance of sewage treatment plants. All junior operation staff should receive inservice training. It is desirable that all sewage treatment plants are run and maintained by operators who hold certificates of competency. The person who would be looking after the maintenance and operation of the plant should be preferably involved in the activities at the time of design, procurement and installation including inspection of equipment at manufacturers' place and their test and trials on completion of system.

The operation and maintenance staff should undergo training and refresher courses from time to time as to keep them conversant with the latest technological advances in the field. The staff should also be encouraged by sending them to other similar plants. They should also be provided with well equipped library for references and also be sent for higher studies.

23.6 RECORDING AND REPORTING

All operating records of the various treatment units in a plant should be properly compiled on a day-to-day basis and daily, monthly and yearly reports prepared, maintained and periodically reviewed. These reports will form a valuable guide to better operation and serve as an important document in the event of a legal suit resulting from nuisance or danger attributed to the plant or for meeting the statutory

requirements about the satisfactory performance of the plant. If possible computers should be used for storing and compiling such voluminous information and to have easy access for prompt information when called for. This would also help in reviewing the performance of the various equipments and plant as a whole.

23.7 CHECK LIST

Appendix-23.1 gives a check list of the operation troubles normally encountered in the sewage treatment plants alongwith the possible remedial measures.

Schedule of preventive maintenance as suggested by the manufacturers of the various equipments shall be adhered to. The use of lubricants and their frequency of application as suggested by the manufacturer shall be adhered to. In addition to the above the schedule of preventive maintenance to be carried out for the major equipments like pump, motor, valves, gears and the M.S.Fabricated structures in the treatment plant etc., shall be done as shown in Appendix 23.2.

In case of establishments falling under the purview of the Factory Act and any other statutory act, then the equipments and the civil structures etc. shall be maintained as directed and as required under the relevant statutory act. All the electrical installations, wiring etc. shall be provided and maintained as per Indian Electricity Rules.

PLANT CONTROL LABORATORY

24.1 GENERAL

A well designed and adequately equipped laboratory under a competent analyst is essential in all sewage treatment plants. Very small size plants such as stabilization ponds need not have their own laboratories if the facilities of a nearby laboratory are available. The results of the laboratory analysis will aid in the characterisation of any waste water, pinpoint difficulties in the operation and indicate improvement measures, evaluate the composition of effluents and thus estimate the efficiency of operation and also measure the probable pollutional effects of the discharge of such effluents upon the receiving water bodies. The analytical data accumulated over a period of time is an important document in safeguarding the treatment plant from allegations of faulty operation. The laboratory should also engage in research and special studies for evolving improvements and innovations in the plant operation. The laboratory therefore must form an integral part of the treatment plant.

24.2 PLANNING OF LABORATORY FACILITIES

24.2.1 Physical Facilities

The actual design of the laboratory depends on the size and type of treatment plants and type and volume of analytical work required to be carried out. Due consideration, therefore should be given to the space requirement for permanent installed equipments and smooth performances of analytical work by the personnel. Necessary provision for future expansions should also be incorporated in the laboratory design.

24.2.1.1 SIZE OF THE LABORATORY

The size and equipments needed for the laboratory depends on the capacity of the treatment plant. Even the smallest plant shall be provided with a laboratory, where at least a few simple analyses such as SS, pH, BOD and residual chlorine can be made. On the other hand large plants providing complete treatment may require a well planned laboratory building with facilities for physical, chemical, biological and bacteriological work. A recommended layout for a sewage treatment plant control laboratory of about 25 mld treatment capacity is presented as Fig 24.1. The total area of the laboratory is about 130 sq.m with a small toilet hall and wash room. It includes the main laboratory hall of 75 sq.m with work benches and smaller rooms of about 13 sq.metres each. One of these rooms can be used as the office and the other can be used as a balance room or instrument room etc. The laboratory should have a separate emergency exit.

24.2.1.2 LOCATION

The laboratory should be easily accessible from any unit of the plant and so located as to provided adequate natural lighting (preferably north light) and ventilation. It should be away from pumps and other heavy operating machinery.

24.2.1.3 FLOOR SPACE

Minimum floor space required to accommodate the equipment necessary to be installed in the room and to avoid interference in the work should be provided. The width of walkways between rows of tables or equipments should be not less than 1.0 m. preferably 1.2m. Total floor space requirement of any work room should be arrived at by accounting for space requirement for all equipments and their placement and the number of staff utilising the room.

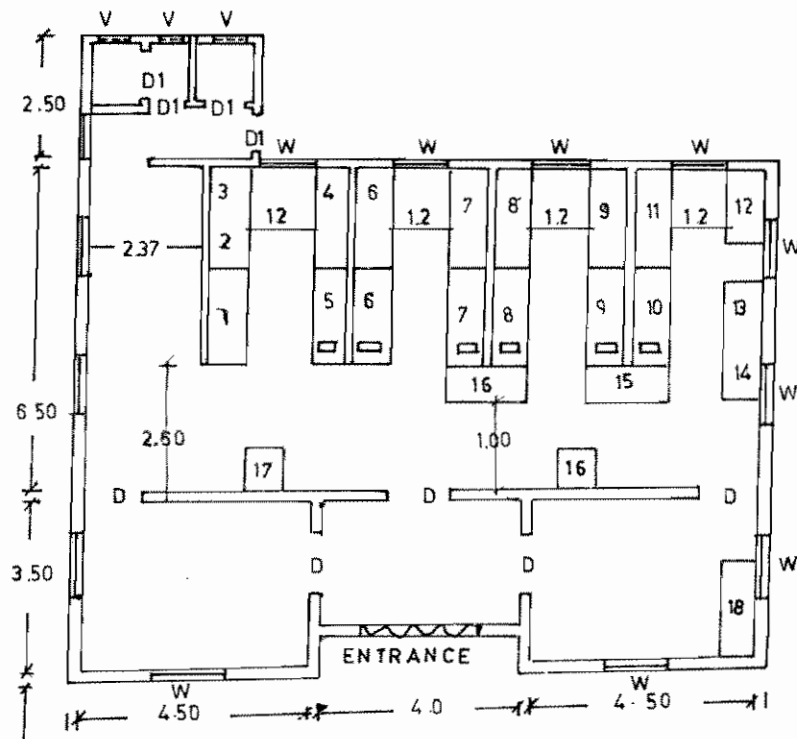

- 1 LAB STIRRER
- 2 CENTRIFUGE
- 3 GAS CHROMATO GRAPH
- 4 PH METER
- 5 TURBIDITY METER
- 6 TITRATIONS
- 7 DISTILLATIONS
- 8 WORK SPACE
- 9 COLORIMETER
- 10 AUTO CLAVE
- 11 HOT PLATE
- 12 ANALYTICAL BALANCE
- 13 DESICCATORS
- 14 HOT AIR OVEN
- 15 WATER BATH
- 16 SAMPLES
- 17 REFRIGERATOR
- 18 BOD INCUBATOR
- 19 DEMINERALISER

FIG.24.1: TYPICAL LAYOUT AND LIST OF EQUIPMENTS
FOR SEWAGE TREATMENT PLANT CONTROL LABORATORY

24.2.1.4 WALLS

Walls should be finished smooth in light colours. The wall space and offsets should be convenient to locate cabinets, benches, hoods, incubators, alongside, without any loss of floor space.

24.2.1.5 LIGHTING

All work rooms in a laboratory including stairways and passages should be well lighted. The window areas in terms of floor area should not be less than 20% and all windows should be fitted with transparent glass panels. Long windows should be preferred to broad windows for greater depth of penetration of light into work rooms. North-South facing should be preferred for prevention of glare on work tables and benches. There must be adequate artificial lighting to supplement day-light, well distributed to provide uniform general lighting with minimum shadow effects. Spot lights should be provided for specific equipment and instruments such as weighing balances, hoods, etc. Adequate number of plug points should be provided for extra lighting and equipment when required.

24.2.1.6 POWER SUPPLY

Adequate electric power supply for at least 200 amps at L.T. voltage is required. Many laboratory equipments require higher voltage and provision for such exigencies should be made. It is also desirable to provide suitable voltage stabilizers to protect sophisticated equipment from damage due to wide fluctuations in the line voltage. This may require consideration in terms of individual units or for the laboratory as a whole.

24.2.1.7 FLOOR

Floors should be of smooth finish but not slippery and should be easy to wash and keep clean. Concrete flooring with terrazo (mosaic) finish and dadoing upto window sill level is recommended.

24.2.1.8 WORK TABLES AND BENCHES

A provision of 10 m² space of work tables and benches per worker should be sufficient. These tables should be preferably located along the walls. Tables located in any other position should have a clear gangway of width not less than 1 m. between adjacent rows. Wall side tables are generally kept 60 to 75 cm wide and centre tables are designed 140 cm wide to allow work space on both sides. Height of tables should be 90 to 95 cm for working in a standing posture and 75 to 80 cm for working in a sitting posture. Table tops should be finished smooth with acid resistant tiles/sheets. A separate rigid table of size 120 cm x 60 cm with revolving adjustable stool should generally be provided for analytical balance. Adequate number of stools should be provided along with work tables and benches. Drains connected to table sinks should also be resistant to attack from corrosive substances.

24.2.1.9 REAGENT CABINETS AND CUPBOARDS

These should be provided in adequate number and size for storing chemicals and reagents and stock solutions, etc. in a systematic order. Sliding glass panelled shutters should be preferred to hinged shutters in these cabinets. The laboratory tables could be provided with cupboards and open glass shelves on the top to provide additional space for storage of chemicals and stock solutions.

24.2.1.10 SINKS

Both table sinks and separate sinks with adequate water supply shall be provided. Table sinks are fitted with gooseneck taps extending high enough above the table to permit washing of litre cylinders. Separate sinks of sufficient size and depth located at suitable points shall also be provided for washing the glassware. Plumbing to sinks and wash basins shall be of proper design and of corrosive resistant materials like PVC particularly for waste water lines.

24.2.1.11 FUME HOODS AND CHAMBERS

Fume hoods and chambers are necessary to prevent spreading of toxic and irritant fumes and odours into other parts of the laboratory and also to prevent condensation of walls, windows and other fixtures causing corrosion. Some analytical work need isolated fume chambers while other could be carried out under an exhaust hood. Positive ventilation with exhaust fans are generally provided for this purpose. Hoods are designed as per standard practice to provide a minimum air velocity of 30 linear m/min.

24.2.1.12 GAS SUPPLY

The plant should provide its own gas supply to the laboratory by installing a gas plant. Efforts should be made to use digester gas if sludge digesters are installed. Gas should be piped to main work tables with hoods with appropriate fixture outlets. Compressed cooking gas in cylinders can also be used out this will require special burners.

24.2.1.13 SPACE FOR ANALYTICAL BALANCE

The analytical balance mounted on a small rigid table to be used in sitting position may be provided in a separate cubicle or enclosure in bigger laboratories. It may also be possible to provide a masonry platform with top surface of polished stone for mounting the balance.

24.2.1.14 CONSTANT TEMPERATURE ROOM

In large plants, provision is sometimes made for constant temperature rooms maintained at 20° C for performances of BOD and other tests. If this is not available commercial type 20° C BOD incubator may be used.

24.2.1.15 SAMPLE PREPARATION ROOM

In large plants employing both primary and secondary processes where number of samples handled daily is large, a separate sample preparation room is very useful. Such room should have refrigerators of suitable capacities. In addition, an attached cold room with storage facilities may also be necessary particularly where bacteriological work is done.

24.2.1.16 MEDIA PREPARATION AND STERILIZATION ROOMS

In large plants where continuous bacteriological analysis is done, additional facilities for media preparation, centrifuging sterilization by autoclaves, etc. are necessary and additional rooms for accommodating these facilities should also be included. Such rooms are usually attached to the laboratory and are located within easy reach of the analysts.

24.2.1.17 SPACE FOR RECORDS

Space for keeping laboratory and plant records should be provided in the laboratory office or in the plant administrative block.

24.2.1.18 WASH AND TOILET FACILITIES

Adequate toilets and wash basins should be provided separately for men and women. Emergency showers should also be provided which can be housed in the work room itself with a curtain to provide temporary privacy. An emergency foot operated spout type eyewash should also be installed in the workroom.

24.2.2 Equipment and Chemicals

24.2.2.1 EQUIPMENT REQUIRED

The type of equipment required for sewage treatment plant laboratory depends on the type of plant, the type of analytical work to be carried out and the frequency of each test to be performed. It is advisable to make initial decisions on the specific analysis to be undertaken, the number of samples, the frequency of sampling and the staff requirement to carry out these analysis, so as to avoid unnecessary purchases and keeping of equipment idle for an indefinite period. Equipment that are not used and are kept idle are often neglected and fall into disuse. Hence, selection of equipment for the plant laboratory requires most careful planning, so that each equipment bought is specifically on the basis of anticipated function and availability of trained staff.

A list of important equipments required for carrying out several analytical works in a laboratory is given in Appendix 24.1. The list is not exhaustive but covers most of the requirements. The quantities required have to be decided as suggested above.

Estimates of essential consumable articles such as chemicals, glassware etc. and recurring replacement in the succeeding years of operation must be worked out with utmost care on the basis of the particular treatment processes for each plant. A list of important tests is given in Appendix 24.2, which serves as a guideline for choosing the required glassware and chemicals for a particular plant.

Refrigerators for reagents and deep freezes provided for preserving samples should be adequate in capacity and numbers

All equipment need a certain amount of maintenance care, particularly those that are electrically operated. Periodic servicing of equipment and checking for their efficiency will save the loss of equipment and prevent faulty analysis leading to work interruptions.

24.2.2.2 STORAGE

All glassware should be stored in an orderly way and used with care to minimize loss due to breakages in handling. Glassware should be cleaned thoroughly after their use and dried before placing in the cupboards and lockers.

Chemicals should be stored in proper shelves and lockers. Toxic chemicals such as arsenic, cyanide etc. should be kept under lock and key and should be under the direct charge of a senior analyst who issues and accounts for them. Acids, bulky glassware etc. which can cause accidents and burns by dropping on the floor should not be stored on high shelves., which need ladders or high stools to reach them.

Chemicals that have a limited life should be bought in such quantities as can be used before their potency is lost.

A stock register for all equipment, chemicals and glassware should be maintained in all laboratories and kept upto date.

24.3 SAMPLING OF SEWAGE AND WASTEWATER

Laboratory analyses will have little value if representative sampling is not done. Sampling points must be located where homogeneity of the sewage or waste water with good mixing of the materials is available. Careless collection of samples give data which may lead to wrong conclusions.

24.3.1 Methods of Sampling

In all cases of sampling, procedures described in 'Standard Methods for the examination of Water and Wastewater (APHA)' or 'Manual of methods for the examination of water, sewage and Industrial Wastes (ICMR)' or other Standard manuals should be followed. Care should be taken to avoid entry of extraneous materials such as silt, scum and floating matters into sampling bottles. This is very important while sampling below weirs, channels and directly from tanks.

24.3.1.1 GRAB SAMPLES

Grab samples are collected when frequent changes in character and concentrations are likely to occur and influence the treatment, undesirable constituents are suspected, the quality is not expected to vary or when samples require on the spot analysis for parameters such as DO, pH and residual chlorine. Representative samples should be taken with good judgement and should be analysed within 2 to 3 hours of sampling. An enamelled bucket or small pail may be suitable for grab sampling.

24.3.1.2 COMPOSITE OR INTEGRATED SAMPLES

Composite samples are required for several analysis such as BOD, SS, nitrites etc. over a period of 12 to 24 hours. The need for the continuous attendance of a person in manual sampling is eliminated in automatic samplers.

24.3.2 Sample Volumes

1 to 2 litres of grab sample would be enough to perform all the tests and repeat some tests if required.

For composite samples, a total quantity of 1 to 2 litres collected over a 24 hour period is adequate. Fractional sample at intervals of 1.2 to 3 hours should be collected in suitable containers, each sample being well mixed and a measured portion proportional to the flow transferred by means of a pipette, measuring cylinder or flask and integrated to form a 1 to 2 litre sample. Hourly records of flow normally available with the Plant Superintendent would facilitate taking of representative samples.

All samples should be immediately transported to the laboratory for analysis. In case there is any delay in transportation, adequate precautions should be taken for fixing the constituents on the spot or preserving the sample in ice.

24.3.3 Selection of Sampling Points

Raw sewage samples should be collected after screens or grit chambers.

Samples of effluent from primary sedimentation or secondary sedimentation tanks should be taken from the effluent trough or pipe or ahead of discharge weirs.

Influent to trickling filter should be collected below the distribution arm and the effluent from the filter from the outlet chamber or at the inlet to secondary sedimentation tank.

A point where there is good mixing should be selected for sampling of mixed liquor in aeration tanks in the activated sludge process.

Influent samples of septic tanks, imhoff tanks, clarifiers and other sole treatment units such as oxidation ponds, oxidation ditches and aerated lagoons should be collected ahead of these tanks, in inlet chambers or channels leading to these units. Effluent samples should be collected outside the units in receiving wells or channels or chambers. Sampling within these tanks should be specified in terms of depth or distance or both.

Samples of raw sludge should be taken from sludge sumps or from the delivery side of the sludge pumps through sampling cocks.

Return sludge sample in activated sludge plant is collected at the point of discharge into primary units or aeration tank.

Samples from mixed primary and secondary sludge should be collected at the point of delivery to the digester.

Digested sludge samples may be drawn from the sampling points in the digester or from the discharge end of the delivery pipe leading to drying beds.

Digester supernatant could be drawn from sampling cocks provided for this purpose or through sampling wells on digester dome.

The flow chart indicating the various treatment units and the sampling points may be exhibited prominently in the laboratory. A list of tests to be carried out daily on the samples may also be displayed as a wall chart. These tests should include pH, BOD, COD and suspended solids.

24.4 TESTS PERFORMED IN THE LABORATORY

Routine tests are performed to control the operation of different treatment units. The procedure suggested in Manuals such as 'Standard methods for the examination of water and waste water' should be followed.

24.4.1 Raw Sewage

Physical tests usually carried out on raw sewage include total suspended and dissolved solids. Chemical tests include those for pH, alkalinity, BOD, COD, nitrogen and its various forms, phosphates, toxic substances and heavy metals.

24.4.2 Primary Sedimentation Tanks

Influent and effluent are analysed for SS, settleable solids, BOD and COD to assess the efficiency. Occasionally volumetric efficiency of tanks is tested by using a dye or tracer, if there is any reason to suspect short circuiting in the tanks. Primary sludge from the tank is analysed for percent solids, organic content and specific gravity, if digestion is practised.

24.4.3 Trickling Filters

BOD, COD, SS, DO, pH, Total Kjeldahl Nitrogen (TKN) and Ammonia Nitrogen, nitrate are determined to evaluate the performance of trickling filters.

24.4.4 Activated Sludge Aeration Tanks

Influent and effluent BOD and COD, DO, ORP, MLSS, SVI for mixed liquor are determined as a routine. Microscopic analyses are conducted to find out whether sufficient ciliated protozoa and rotifers are present. Special tests are made for microbial growth rate and oxygen uptake rate to assess sludge growth and oxygenation efficiency.

24.4.5 Secondary Settling Tanks

Effluents are analysed for SS, settleable solids, filtered and unfiltered BOD, COD, DO, Alkalinity, TKN and nitrates as a routine. Secondary sludges are analysed for percent solids (Total, volatile and fixed) and specific gravity, when digestion is practised.

24.4.6 Septic Tanks and Clarifiers

Samples are periodically analysed for settleable solids, total and suspended solids (fixed and volatile), BOD, and COD on both influent and effluent. The pH, volatile acids and alkalinity are determined on tank contents. Bottom sludges are periodically examined for percent solids and for organic and fixed solids. Occasionally effluents are examined for pathogens and viable ova of hookworm and ascaris.

24.4.7 Sludge Digester

Maintenance of proper environmental conditions is necessary for efficient digestion process. Characterisation of digested sludge is required for further disposal and also to determine the sludge balance in the digester and efficiency of digestion. Digester content is analysed for pH, volatile acids and alkalinity. The digested sludge is analysed for pH, colour, texture, percent solids, volatile solids and alkalinity, volatile acids and NPK percentages. Determination for total solids, pH, alkalinity, nitrogen, suspended solids, BOD and COD are made on the supernatant.

24.4.8 Stabilization Ponds

Influent and effluent samples are analysed for SS, BOD, COD, pH, DO, and turbidity to determine the efficiency of ponds. The pond samples taken from different points and at different times for 24 hours in a day are analysed for DO, pH, alkalinity and algal cell concentration to assess the conditions of the pond for diurnal or seasonal variations. Biological and bacteriological analysis are carried out periodically to study the flora and fauna prevalent in the ponds. pH, measurements, COD, BOD, and ORP tests are essential guides in the control of anaerobic lagoons, specially where industrial wastes are treated. Colour changes are valuable guide in forecasting of adverse conditions in the pond. Visual inspection of colour or colour determinations are therefore found useful.

24.4.9 Digester Gas

Where digester gas is collected for use in the plant as fuel for development of power, a complete gas analysis should be done frequently to determine carbon dioxide and methane and other constituents of the gas like moisture and H₂S.

24.4.10 Residual Chlorine

Where the effluents are chlorinated before discharging into water or land, the residual chlorine test is done regularly to ensure proper chlorination at all times. Usually one sample every 4 hours is sufficient.

24.4.11 Special Tests

Special tests may be required to determine the presence of materials which may create operating difficulties or retard the progress of purification or for meeting pollution control standards. Such materials include various types of oils and grease, toxic chemicals like copper, cyanide, zinc, chromium, lead and other heavy metals, excess sulphides, ABS and radioactive materials.

24.5 DISPOSAL OF LABORATORY WASTES

Any office or other place where a number of people work, requires a proper waste disposal system. In the case of a Sewage Treatment plant Laboratory, special care has to be taken since the laboratory handles harmful chemicals and the samples themselves are capable for transmitting pathogens.

24.5.1 Solid Waste

Solid waste may include filter residues used cotton plugs etc. These should be collected and burnt.

24.5.2 Liquid Wastes

Since the laboratory is attached to a sewage treatment plant, it will be possible in most cases to drain the laboratory wastes to the inlet chamber of the treatment plant, if necessary by pumping.

But as the laboratory wastes may also contain concentrated acids and alkalies, it may be necessary to provide a small holding tank where the concentrated chemicals will be diluted and neutralised to avoid the possibility of affecting the biological activity of the treatment plant.

24.5.3 Radioactive Wastes

If radioactive materials are present in the waste samples special precautions will have to be taken to protect the laboratory staff. Advice on this aspect may be obtained from the Atomic Energy Department.

24.6 ANALYSIS OF DATA

All analysis carried out should be properly recorded. Routine daily analysis, periodic analysis and special analysis should be recorded separately. Copies of these reports should be sent to the plant Superintendent immediately after the analysis is done with explanatory notes to indicate any unsatisfactory conditions or abnormalities. The Superintendent should study the reports and direct the operating staff for proper corrective measures in the operation schedule. Such measures taken should be reported to the laboratory scientists who should check the efficiency of corrective measures by resampling and analysis. Corrective measures followed by sampling and analysis should be repeated till such time as satisfactory results are obtained.

Data collected over period of time on various parameters of plant control should be analysed and represented on charts and graphs and displayed in the laboratory for ready reference by the supervisory staff and visitors. These should be included in the weekly, monthly and annual reports of the laboratory.

24.7 COMPUTERISATION OF LABORATORY DATA

With the availability of personal computers and softwares at reasonable cost, the advantages of electronic data processing for storage, retrieval and processing of laboratory test results are obvious. To start with, the analysis results may be entered from the daily records into computer storage. Simple programme can be written for retrieval and presentation of data relating to any particular parameter. This can be in the form of display of data for a fixed period or weekly or monthly averages or the results of analysis carried out on samples collected at a particular time of the day for the period to be studied etc. A slightly more detailed programming can be prepared for the computer to go through the results of specified parameters entered daily and display or print out any figures which exceed a present value. This can be immediately passed onto the Treatment Plant Staff for investigation and rectification. The computer can also be programmed to display and print out graphs showing the variation in any specified parameters over a period of time.

Analytical instruments are also available for carrying out tests automatically on a large number of samples simultaneously and electronically feed the data directly into the computer using a data logger module.

24.8 PERSONNEL

Laboratories of large plants should be under the charge of a qualified and experienced analyst supported by junior technical staff having background in the field of chemistry, biology and bacteriology. The analyst should assimilate the details for functioning of the plants by experience and acquire the necessary preparedness for receiving further specialised training including performance interpretation and application of advanced techniques which enable him to participate in the efficient operation of the treatment unit.

In the case of small plants the laboratory may be under the charge of a person having some training in analysis of sewage.

FLOW MEASUREMENT

25.1 INTRODUCTION

Measurement of wastewater flow is very essential for the proper design, operation and maintenance of all waste management systems and for process control. Flow records are also very useful for future planning and expansion.

Suitable flow measuring devices can be installed at different locations in a wastewater collection and treatment system.

25.2 METHODS OF FLOW MEASUREMENTS

Two principal types of flow measurements are the direct discharge methods and the velocity-area methods.

25.2.1 Direct Discharge Methods

In these methods, the rate of discharge is related to one or two easily measurable variables. The principal methods and applications are described below :

25.2.1.1 NOTCHES AND WEIRS

a) *Notches*

These are cut from thin metal plates. They are either triangular, rectangular, or trapezoidal.

i) **Triangular notches: (Fig 25.1)**

90° triangular notches are commonly used for measuring quantities of flow upto 1.25 m³/s.

Specification for materials

The plate should be smooth and made of rust proof and corrosion - resistant material. The thickness should not exceed 2 mm, with the downstream edge chamfered at an angle of not less than 45° with the crest surface.

Measuring of head causing the flow

The head causing flow over the notch is usually measured by standard hook gauge upstream at a distance 3 to 4 times the maximum depth of flow over the notch.

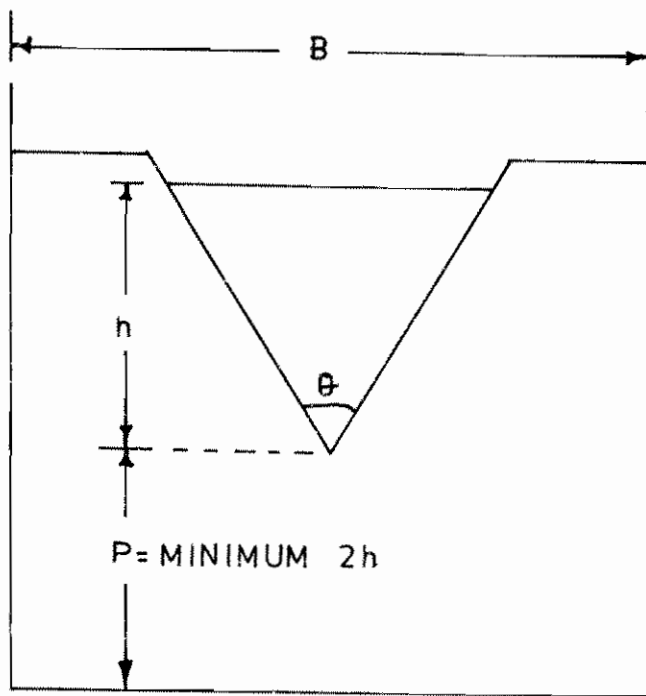

FIG. 25.1 : V - NOTCH

Discharge Equation

The discharge Q (in m^3/s) for V-Notch is given by the expression:

$$Q = \frac{8}{15} C_e \sqrt{2g} \tan \frac{\theta}{2} h^{2.5} \quad (25.1)$$

Where

- C_e = effective discharge coefficient
 g = acceleration due to gravity (9.806 m/sec^2)
 θ = angle of the notch at the centre
 h = measured head causing flow, in metres.

For 90° V-Notch which is generally used, the discharge is given by the expression:

$$Q = 2.362 C_e h^{2.5} \quad (25.2)$$

C_e values vary from 0.603 to 0.686 for values of head varying from 0.060 to 0.377 m.

Limitations

The triangular notches should be used only when the head is more than 60 mm.

Accuracy

The values obtained by the equation for triangular notches would vary by $\pm 3\%$ from the true discharge for discharges from 0.008 to $1.25 \text{ m}^3/\text{s}$.

ii) Rectangular Notches

There are two types of rectangular notches viz (1) with end contractions and (2) without end contractions. The width of the notch in either case should be at least 150 mm.

With End contractions (Fig 25.2)

The contraction from either side of the channel to the side of the notch would be greater than 0.1 m.

The discharge (m^3/s) through a rectangular notch with end contractions is given by the equation:

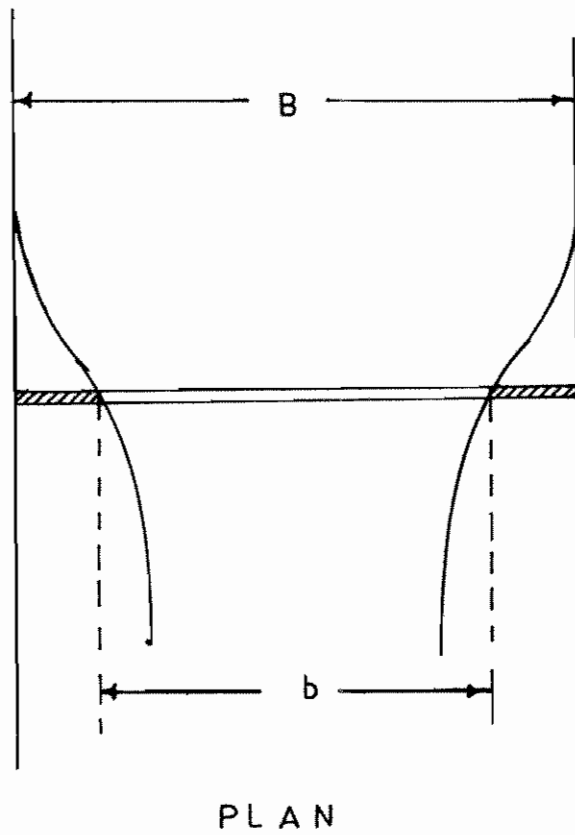

FIG.25.2 : RECTANGULAR NOTCH (WITH END CONTRACTIONS)

$$Q = \frac{2}{3} C_d \sqrt{2g} b_e h_e^{\frac{3}{2}} \quad (25.3)$$

Where

- b = width of the notch, m
- b_e = effective width (m) = actual width of the notch $b + K$ (value of K being 2.5 mm, 3 mm and 4 mm for b/B ranges of up to 0.4, 0.4 to 0.6 and 0.6 to 0.8 respectively);
- b/B = ratio of the width of the notch to the width of the channel
- h_e = effective head (m) = actual head measured (h) + 1 mm ; and
- C_e = varies from 0.58 to 0.72 for values of b/B from 0 to 0.8

Without end contractions (Fig 25.3)

If the end contraction from either side of the channel is less than 1 mm, it will be treated as a notch without end contraction.

The discharge (m^3/s) through a rectangular notch without end contractions is given by the following expression:

$$Q = \frac{2}{3} C_d \sqrt{2g} b h_e^{\frac{3}{2}} \quad (25.4)$$

Where

- b = width of the notch (m)
- h_e = effective head m = actual measured head (h) + 1.2 mm
- C_e = $0.602 + 0.075 h/p$

Where

- p = height of the bottom of the notch from the bed of the channel, m.

iii) Trapezoidal Notches (Cippoletti Notches) (Fig 25.4)

The main advantages in a trapezoidal or Cippoletti notch is that as the flow passes over the weir, the end contractions are either eliminated or considerably reduced.

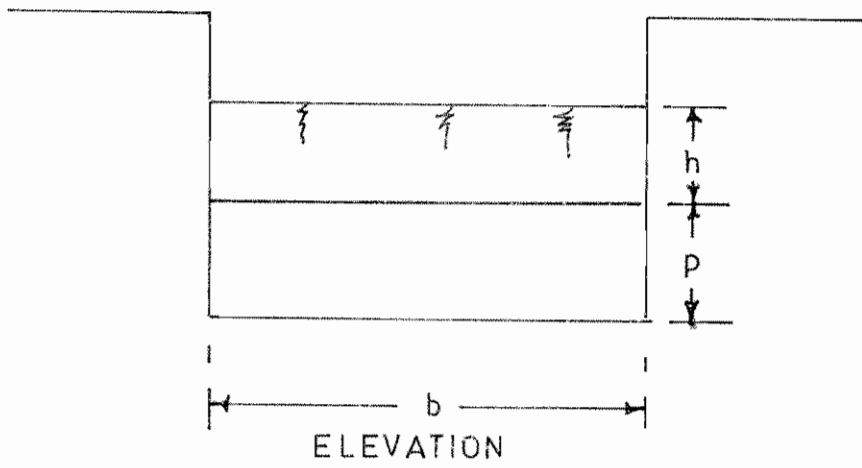

FIG.25.3 : RECTANGULAR NOTCH (WITHOUT END CONTRACTIONS)

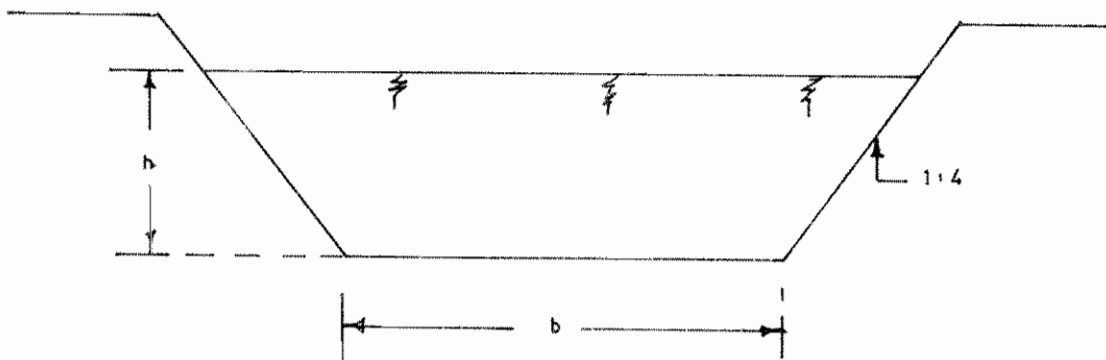

FIG.25.4 : TRAPEZOIDAL NOTCH (CIPPOLETTI WEIR)

The sides of the notch should have a slope of 1:4 such that the top width of discharge is equal to the bottom width of the notch (b) + half the head of water over the sill of the notch ($1/2 h$). Thus the loss of discharge due to end contractions is made good.

$$\text{Discharge equation (Q)} = 1.859 C_e b h^{3/2} \quad (25.5)$$

Where

b	=	bottom of the notch, m
h	=	head over the sill, m and
C_e	=	0.623

Installation requirements

The approach channel should be reasonably smooth, free from disturbance and straight for a length equal to at least 10 times the width. The structures in which the notch is fixed shall be rigid and water-tight and the upstream face vertical. The downstream level should be always at least 5 cm. below the bottom-most portion of the notch (inverted apex) ensuring free flow.

b) Weirs

These are similar to rectangular notches but the thickness in the direction of flow is considerable and therefore co-efficient of discharge will be less. The installation conditions will be the same as for the notches.

i) Without end contraction (Suppressed weirs) (Fig 25.5)

The discharge equation to be used is:

$$Q = 0.5445 C_e \sqrt{g} b h^{3/2} \quad (25.6)$$

C_e varies from 0.864 to 1.0 depending upon the h/b value (ratio of measured head to length of the crest of the weir in the direction of flow) from 0.4 to 1.6. For h/b values lower than 0.4, C_e may be taken as 0.864.

ii) With end contraction (Fig 25.6)

The discharge in this case is given by the following equation.

$$Q = 0.5445 C_e \sqrt{g} (b - 0.1 nh) h^{3/2} \quad (25.7)$$

Where 'n' is the number of Contractions.

Limitations

The weirs should be used only when the head is more than 60 mm. Minimum width of the weir should be 300 mm.

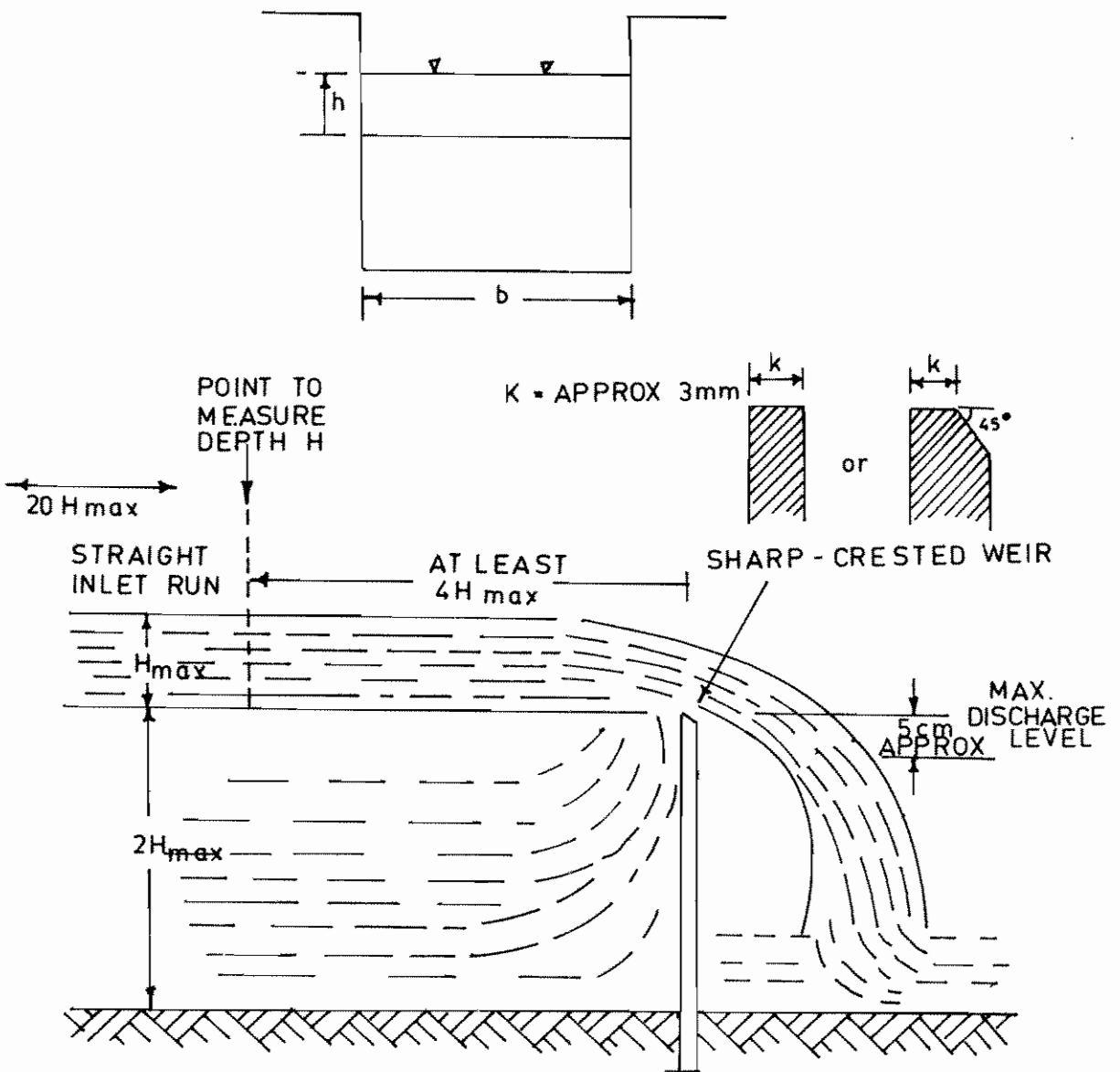

FIG. 25.5 : PROFILE OF SHARP- CRESTED SUPPRESSED RECTANGULAR WEIR

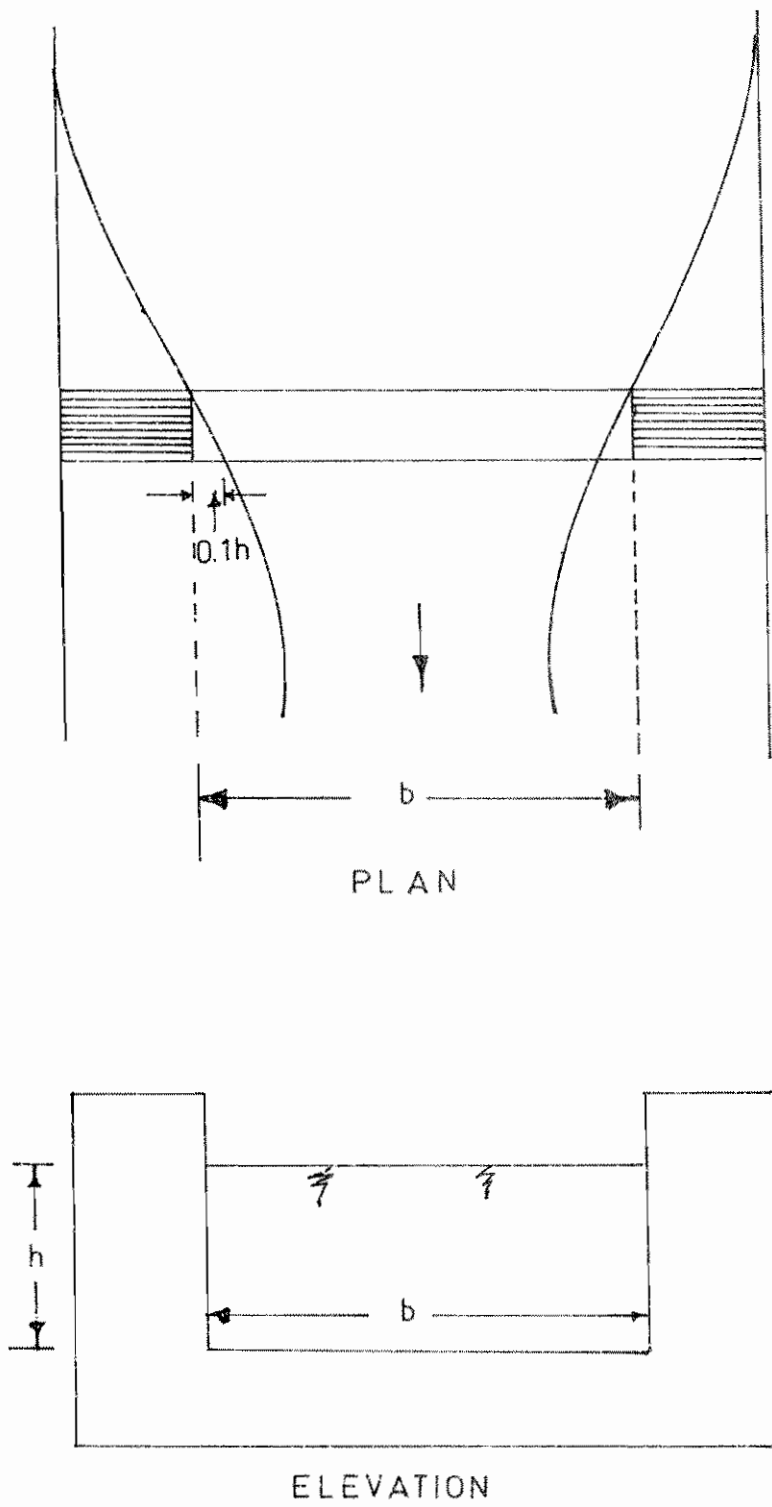

FIG. 25.6 : RECTANGULAR WEIR WITH END CONTRACTION

Accuracy

The discharge values obtained by weir measurements would vary by $\pm 5\%$ of the true discharge.

25.2.1.2 FLUMES (FREE FLOWING)

There are two types of flumes, namely: a) standing wave flumes in which standing wave or hydraulic jump is formed down stream and b) venturi flumes.

a) **Standing Wave flumes**

In a channel where its cross sectional area is reduced resulting in the formation of a throat, there will be a drop in water surface and this may be related to the discharge. If the throat velocity exceeds the critical velocity, it is called a standing wave flume or critical depth flume. Standing waves will be formed at the throat of the flume. Since the velocity is critical, the downstream variations in depth do not affect the upstream depth till the submergence ratio exceeds 0.7. Example of a standing wave flume is a Parshall Flume (Fig 25.7).

i) **Parshall Flume**

A Parshall flume is an open constricted channel which can be used both as a measuring device and also as a velocity control device. It involves negligible headloss and can work under submerged conditions upto certain limits. The limits of submergence are 50% in case of 150 mm throat width and 70% for wider throat widths upto 1 m. The flume is also self cleansing and there is no problem of clogging. The design equations for Parshall Flume are covered under 11.2.5.5 (c).

b) **Venturi Flumes**

Unlike the previous case, if the throat velocity is less than critical, the discharge will be a function of the difference between the upstream and throat depths. In these, standing waves will not be formed. Such flumes are called venturi flumes (Fig 25.7).

i) **Discharge Equation**

The discharge equation is given by

$$Q = 0.5445 C_v C_e \sqrt{g} b h^{3/2} \quad (25.8)$$

Where

C_v is the coefficient of velocity which varies from 1.04 to 1.15. C_e is the effective coefficient of discharge varying from 0.885 to 0.99 depending upon H/l varying from 0.05 to 0.70 where l is the length of throat in the direction of flow.

ii) **Limitations**

Venturi flumes should be used only when head available is between 50 and 1800 mm. Minimum width of the flume should be 90 mm.

iii) Accuracy

The discharge values obtained by measurement with venturi flumes would vary from 95% to 105% of the true discharge.

The installation conditions for the flumes are the same as for notches.

25.2.1.3 VENTURI METERS

This is used to measure flow in closed conduits. It consists of three parts (i) The inlet cone in which the diameter of the pipe is gradually reduced. (ii) the throat or constricted section and (iii) the outlet cone in which the diameter increases gradually to that of the pipe in which the meter is inserted (Fig 25.8).

The throat dimension in standard meter tubes is from 1/3 to 1/2 the diameter of the pipe. Its length is only a few centimeters, just sufficient to allow a suitable pressure chamber or piezometer ring to be inserted in the pipe at this point. A piezometer ring is inserted at the upper or large end of the inlet cone and the determination of the quantity of water flowing is based on the difference in pressure observed or indicated at this point and at the throat of the meter.

The equation for computing discharge through a Venturi meter is given by:

$$Q = \frac{A_1 A_2 \sqrt{2gh}}{\sqrt{A_1^2 - A_2^2}} \quad (25.9)$$

Where

- Q = discharge in m³/s.
 A₁ = Area at upstream end, m²
 A₂ = Area at throat of meter, m²
 h = (h₁ - h₂) Differential head i.e., the pressure head difference between the upstream and the throat in meters.

Under actual operating conditions and for standard meter tubes, including allowance for friction, the above equation reduces to the form.

$$Q = CA_2 \sqrt{2gh} \quad (25.10)$$

Where C = C₁ C₂

$$C_1 = \frac{A_1}{\sqrt{A_1^2 - A_2^2}} \quad (25.11)$$

and

C₂ - coefficient of friction

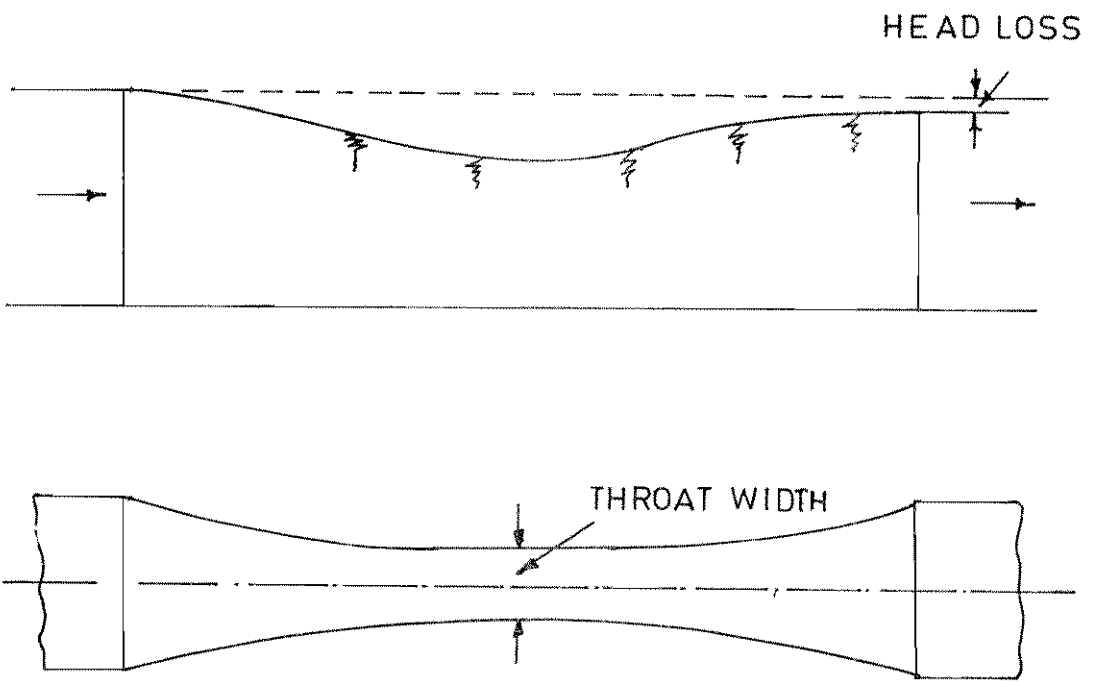

FIG.25.7 : VENTURI FLUME

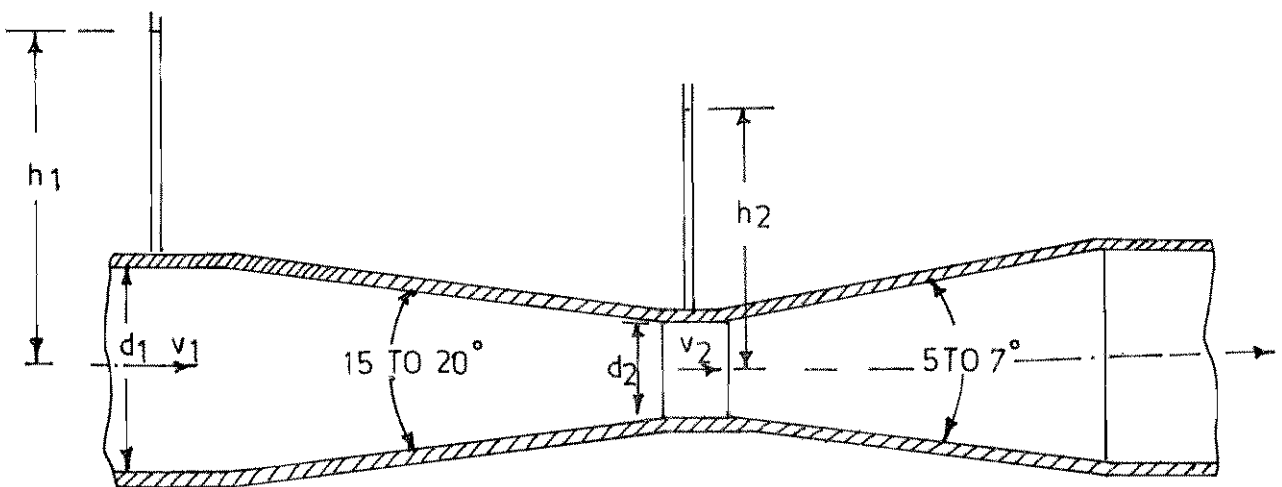

FIG.25.8 : VENTURIMETER

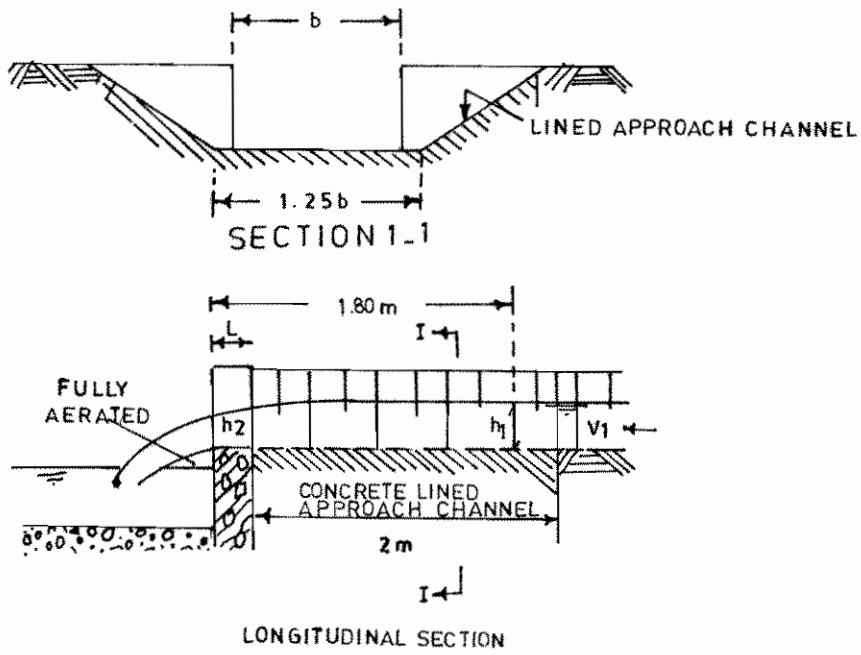

FIG.25.9 : DROP

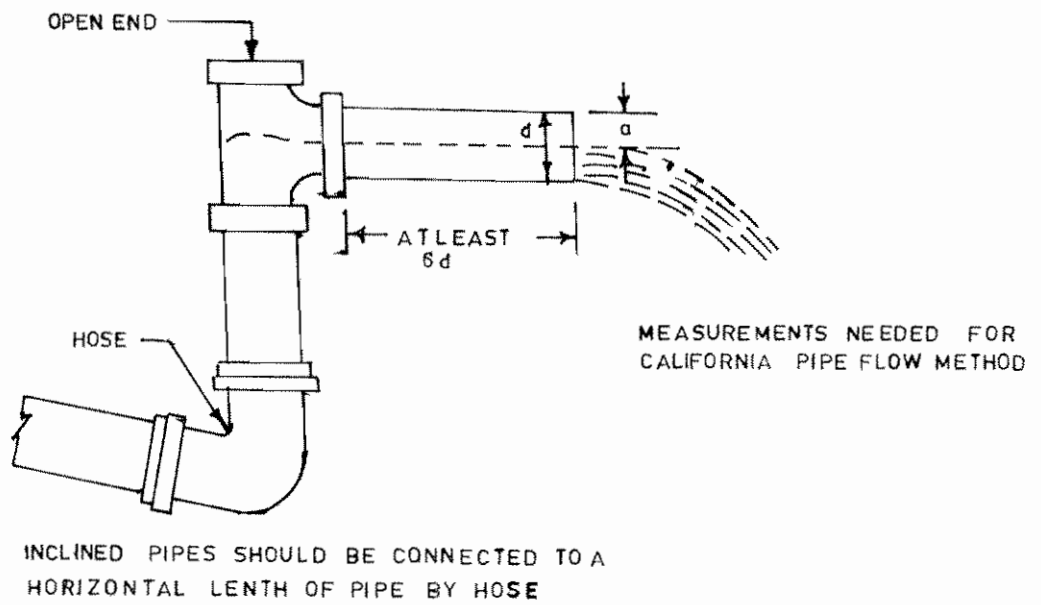

FIG.25.10 : CALIFORNIA PIPE FLOW METHOD

For standard meter tubes in which the diameter of the throat is between 1/3rd and 1/2 that of the pipe, the value of C_1 ranges from 1.0062 to 1.0328 and that of C_2 from 0.97 to 0.99. Thus C has a range of values from 0.98 to 1.02.

Where venturi meters are used for measuring wastewater, there should be valves at each annular chamber or piezometer ring, so that the pressure openings can be closed. These valves may be so designed that in closing, a rod is forced through the opening to clean out any matter that may have clogged it. When all these valves have been closed, the plates covering the handholes in the pressure chamber may be removed and the chamber may be cleaned by flushing with a hose or otherwise. Such flushing at short intervals is usually necessary if venturi meters for wastewater are to be maintained in good operating condition.

25.2.1.4 DROPS (FIG.25.9)

i) Discharge Equation

When the flow falls freely from a channel or conduit to a lower level (ground), measurement can be conveniently made at the point of drop which offers a rough estimate of the discharge. In the approach channel there should be a minimum straight length of 20 times the end depth (h_c). The ratio of the end depth to the critical depth in horizontal and mildly sloped channels has a value of 0.70 and from the critical depth d_c the discharge may be calculated as

$$Q = d_c^{3/2} \sqrt{g} \quad b \quad (25.12)$$

Where b is the width of the channel.

The critical depth is defined as the depth for which the specific energy ($h + V^2 / 2g$ where h is the depth of water and V the velocity of flow at that point) is a minimum and is the depth of flow above which the flow is supercritical and below which the flow is subcritical.

ii) Limitations

Width of channel should be a minimum of 300 mm. Critical depth d_c should be minimum of 50 mm.

iii) Accuracy

The discharge value obtained by measurements made at drops would vary by $\pm 10\%$ of the true discharge.

25.2.1.5 CALIFORNIA PIPE (FIG.25.10)

This involves measuring the depth of flow at the free falling end of a partially filled horizontal pipe (Fig 25.10). The discharge pipe should be horizontal and should have a length of at least six times the pipe diameter. When the pipe is flowing almost full, an air vent should be installed to ensure free circulation of air in the unfilled portions of the discharge pipe. In addition, the approach velocity should be kept a minimum. The discharge can be computed using the following equation.

$$Q = 4.686 [1 - (a / d)]^{1.88} d^{2.38} \quad (25.13)$$

Where

Q = discharge, m^3/s .

- a = distance from inner bottom of pipe to top of water surface measured at point of discharge. m.
- d = diameter of the pipe, m

25.2.1.6 FLOW NOZZLES (FIG.25.11)

Nozzles flow meters in pipes make use of the Venturi principle, but use a nozzle inserted in the pipe instead of Venturi tube to produce the pressure differential. For nozzles placed at the end of pipes, only a single pressure connection is needed to measure the head.

25.2.1.7 ORIFICE PLATE (FIG.25.12)

Orifice plate is a plate with a cylindrical opening in the centre inserted into a closed pipe line. The flow-rate is determined from differential - pressure readings. For computing the discharge through Orifice plates and nozzles, the following equation is used

$$Q = \alpha \frac{\pi d^2}{4} \sqrt{\frac{2\delta P}{e}} = 0.035d^2 \sqrt{\delta p} \quad (25.14)$$

Where

- Q = discharge, m³/s
- α = diameter of the orifice or nozzle, m
- δP = Differential pressure in kgf/m²
- e = density of water, 1000 kg/m³ and
- α = Constant varying from 0.6 to 0.765 for orifice plates for flows with Reynolds number from 5×10^3 to 1×10^7 and 0.99 and 1.19 for nozzles for flows with Reynolds number from 2×10^4 to 1×10^6 .

The discharge values obtained in both the cases vary by $\pm 2\%$ of the true discharge.

25.2.1.8 MAGNETIC FLOW METERS

The design of electromagnetic flow meters is based on the fact that when an electrical conductor is passed through an electromagnetic field, an electromotive force or voltage proportional to the velocity of the conductor is induced in the conductor.

In actual operation, the water or wastewater in the pipe serves as the conductor. The electromagnetic field is generated by placing coils around the pipe. The induced voltage in them is measured by electrodes placed on either side of the pipe. If the pipe is a conductor, the electrodes need not penetrate the wall of the pipe. Where the pipe is constructed of nonconductive materials, the electrodes, must penetrate the pipe wall and in some cases protrude into the liquid. The advantage of this flow meter is that it does not create any headloss and is independent of suspended solids in water. In the velocity range of 1 to 10 mps the accuracy is $\pm 1\%$ of max. flow while at the lower velocities, it is $\pm 2\%$ of max. flow.

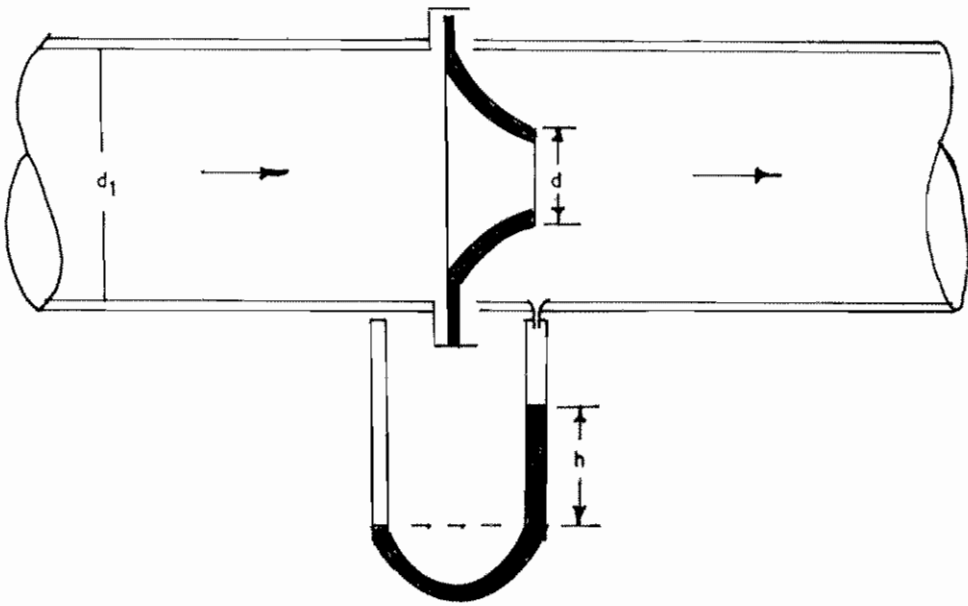

FIG. 25.11 :FLOW NOZZLE METER

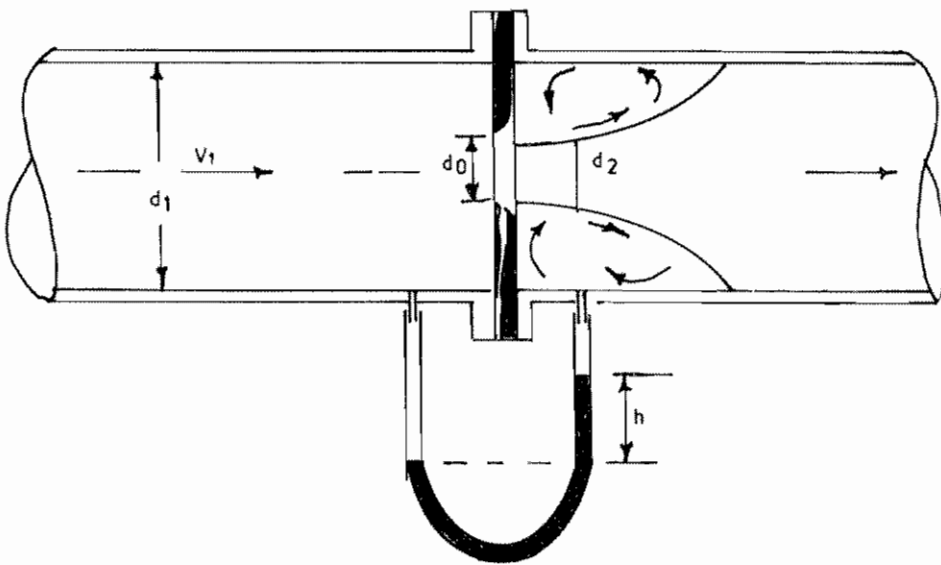

FIG. 25.12 :ORIFICE METER



25.2.1.9 ULTRASONIC FLOWMETERS

Ultrasonic flowmeters are based on the following principle:

If two probes capable of emitting and receiving ultrasonic waves are immersed in a moving liquid in such a way that each is able to receive the wave signals sent out by the other, it will be found that there is a difference in the time of propagation depending on whether the sound wave is travelling upstream or downstream (differential velocity).

- if
- V = the Velocity of the liquid
 - d = the distance between the probes
 - C = the velocity of sound in the medium
 - Θ = the angle between the velocity vector and the orientation of the probes

then we can write the difference in the propagation time as follows :

$$\Delta T = \frac{2vd\cos\theta}{C^2} \quad (25.15)$$

The working principle of an ultrasonic flow meter is shown in Fig 25.13. This equipment also gives a linear reading of the flow rate and is capable of measuring flow rates of clean or slightly polluted liquids ranging from a few litres to several hundred cubic meters per hour.

25.2.1.10 VOLUMETRIC MEASUREMENT

In this method, the volume of liquid discharged over specified time period is measured. This is usually done for small flows. Alternatively the weight of fluid discharged over a specified time period is weighed and converted into a flow rate.

25.2.1.11 DILUTION METHOD

This is based on the fact that a chemical or radioactive tracer injected into a stream or pipe will be completely and uniformly mixed with the natural flow and that the diluted concentration downstream will decrease with increasing discharge. Chemical concentrations are measured by titration or colorimetric methods and radioactivity by Geiger counter. This method permits the direct computation of discharge without measurement of cross-sectional area. The usual tracers used are sodium chloride, sodium dichromate, manganese sulphate, sodium nitrite, lithium and potassium salts, dyes like sodium fluorescein and radioactive isotopes.

These techniques are of particular value in hilly streams where the other methods of measurement gaugings are not feasible and also in wastewater gaugings.

Analysis of concentration of the injected solution and the diluted samples at a position far enough downstream for ensuring complete mixing, allows determination of the discharge of the stream. If C_1 and C_2 are the concentrations of injected solution and the diluted downstream samples respectively and Q and q are the discharge rates of the main flow to be measured and added chemical flow respectively then,

TABLE 25.1
COMPARISON OF OPERATIONAL CHARACTERISTICS OF FLOW MEASUREMENT
DEVICES INSTALLED AT DIFFERENT LOCATIONS

Alternative Location of Flow Measurement Device	Sensitive to Fluctuation in Flow	Measurement Represents the Avg. Flow treated	Affectd by Debris	Affected by silt or other settleable solids	Measurement useful for Plant Operations	Measurement useful for Effluent receiving Source
Within Intercepting sewer or manhole	Yes	No	Yes	Yes	Yes	No
At the head of the plant	Yes	No	Yes	Yes	Yes	No
Below bar screen	Yes	No	No	Yes	Yes	NO
Below grit removal or sedimentation facility	No	No	No	No	Yes	No
Before outfall	No	Yes	No	No	No	Yes

**TABLE 25.2
EVALUATION OF VARIOUS TYPES OF DEVICES COMMONLY USED FOR WASTEWATER MEASUREMENT**

	Application		Flow Range and accuracy		Effect of solids in waste water	Head Loss	Power requirement	Simplicity and Reliability	Unattended operation	Maintenance requirement	Ease of Calibration	Cost	Portability	Application
	Pressure flow	Open channel	Range	Accuracy										
Venturi Meter	Y	N	10 : 1	± 0.5	F	L	L	G	G	M	G	H	N	Force main, Wastewater
Flow nozzle meter	Y	N	5 : 1	± 0.5	H	M	L	G	G	L	G	M	N	- do -
Orifice Meter	Y	N	5 : 1	± 0.5	H	H	L	G	G	H	G	L	Y	- do -
Electromagnetic meter	Y	N	20 : 1	± 1.0	S	L	M	F	G	M	G	H	N	Force main wastewater Sludge
Parsnall flume	N	Y	20 : 1	± 5	S	L	L	G	G	L	G	M	Y	Channel Wastewater sludge
Weirs	N	Y	20 : 1	± 5	H	H	L	G	G	M	G	L	Y	Manhole treatment unit wastewater
Depth measurement	N	Y	10 : 1	± 5	M	L	L	G	M	L	P	L	Y	Interceptor wastewater sludge
Open Flow Nozzle	N	Y	20 : 1	± 1	S	H	L	G	G	M	F	L	Y	Over all, discharge point waste-water sludge

409

Effect of solids is substantially smaller if solids bearing or continuous flushing type Venturi Meter is used.

F = Fair, G = Good, H = High, L = Low, M = Medium, N = No, P = Poor, S = Slight, Y = Yes

TABLE 25.3
TYPES OF FLOW MEASUREMENT DEVICES FOR DETERMINING LIQUID DISCHARGES

<u>Flow measurement device</u>	<u>Method Employed</u>
1. <u>For pressure pipes</u>	
a. Venturi meter	Direct-Discharge method
b. Flow nozzle meter	- do -
c. Orifice meter	- do -
d. Pitot tube	Velocity-Area Method
e. Electromagnetic meter	Direct-Discharge method
f. Rotometer	Velocity-Area method
2. <u>For open channels</u>	
a. Flumes (Parshall)	Direct-Discharge method
b. Weirs	- do -
c. Current meter	Velocity-area method
d. Pitot tube	- do -
e. Depth Measurement	- do -
3. <u>Flow from freely discharging pipes</u>	
i. <u>Pipes Flowing Full</u>	
a. Nozzles and Orifices	Direct-Discharge Method
b. Vertical open end flow	- do -
ii. <u>Pipes Flowing partly full</u>	
a. Horizontal sloped open-end pipe	Direct-Discharge method
b. California pipe method	- do -
4. <u>Miscellaneous methods</u>	
a. Dilution method	Direct-Discharge method
b. Bucket and stop-watch	- do -
c. Volumetric measurement (measuring level change in tank)	- do -
d. Water meter	- do -
e. Pumping rate	- do -

An evaluation of the various types of devices commonly used for wastewater flow measurement is given in Table 25.2.

TABLE 25.4
MAIN MEASUREMENT INSTRUMENTS

Point concerned	Principle of Measurement (in general)	Instruments			Notes
		I	R	S	
<u>Effluent flows</u>					
- Raw effluent	Weir or Parshall flume	1	2	2	Total
- Settled effluent	- do -	2	3	3	Total or per settling tank
- Excess effluent extracted	- do -	3	3	3	total
- Effluent Passed for biological treatment	- do -	2	3	3	per treatment line
- Purified effluent	Weir	1	1	1	total
<u>Sludge flows</u>					
- fresh sludge	Electro-magnetic flow meters	1	2	1	Total and where there is no thickener
- Return sludge	Weir, Parshall or venturi	2	3	3	total or per line
- Excess sludge	Weir	2	3	3	total or per line
- Digested sludge	Electro-magnetic flowmeters	1	1	1	total
- Thickened sludge	- do -	1	2	1	per thickener
<u>Air Flows</u>					
- General	Orifice or Venturi	1	1	1	total
- By blower	- do -	2	3	3	
- By treatment line	- do -	1	3	3	
<u>Digested gas</u>					
- Gas flows produced	Orifice - Venturi meter	1	2	1	global or per digester
- Gas flows consumed	- do -	2	3	2	global or per unit
<u>Sludge drying</u> (filtration or centrifuging)					
- Flow of feed sludge	Electro - magnetic flowmeters	1	2	1	(if this flow is different from the flow of digested or thickened sludge)
I = Integrating R = Recording S = summing	1. Highly desirable 2. Desirable 3. Optional (for highly technical plant)				

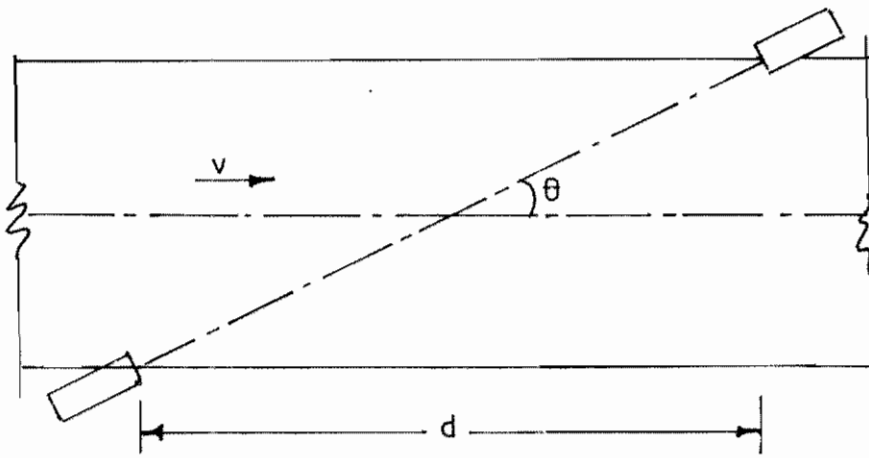

FIG.25.13 : DIAGRAM SHOWING THE WORKING PRINCIPLE OF AN ULTRASONIC FLOW METER

$$\frac{Q+q}{q} = \frac{C_1}{C_2} \quad (25.16)$$

If q is very small relative to Q

$$\text{then } Q = q \frac{C_1}{C_2} \quad (25.17)$$

25.2.1.12 CONSTANT RATE INJECTION METHOD

The concentration solution of chemical is usually prepared at the gauging site in a tank and thoroughly mixed. This is then injected into the stream at a controlled constant rate of flow, the device used being a constant volume displacement pump or constant head tank. The rate is measured with flow meter in the line with a high degree of accuracy. A steady injection of chemical into the stream should continue for a period equal to the time of reaching steady conditions plus time of sampling at the sampling cross-section. A highly turbulent flow and a narrow reach are desirable. The reach should be long enough for complete mixing to occur. Empirical formulae are available in arriving at the mixing length. The samples are taken upstream from the injection point, from the concentrated solution at the point of injection and from two or three points at the sampling section.

b) *Integration (Sudden Injection) Method*

This is preferred for very large flow measurements in a natural stream. A known volume of chemical tracer solution of concentration C_1 is introduced into the stream as quickly as possible. Sampling of water is carried out at a point sufficiently far downstream ensuring complete lateral mixing, for a period during which the tracer passes (which included the complete injection cycle).

The stream discharge Q is given by the expression

$$Q = \frac{q C_1}{T C_2} \quad (25.18)$$

Where T is the total sampling time and C_2 is the average concentration of tracer in water removed at the sampling point during the sampling period.

This expression holds when the tracer is not naturally present in the stream. In this method constant rate injection equipment is not required and the procedure is simple. No calibration is needed and it is not necessary to measure the dimensions of the test section. This method can be used with radioactive tracers.

25.2.2 Velocity-Area Methods

Using the velocity area methods, the flow rate is determined by multiplying the velocity of flow (in m/s) by the cross-sectional area (in m²) through which the flow is occurring. The principal methods of measuring velocity are given below :

25.2.2.1 CURRENT METERS

Current meter measurements may be used to determine accurately the velocity of flow in large sewers or open channels, provided there is not too much paper or other suspended matter present to clog the meter. There are several methods of gauging the velocity.

1. One-two and multiple point methods
2. The method of integrating in sections
3. The method of integrating in one operation

In the one-point method, the meter is held at 0.6 depth from the water surface at the centre of the stream. This is supposed to give the rough mean velocity of the stream. In the two-point method, the velocity is observed at 0.2 and 0.8 of the stream depth and average is taken. In the multiple-point method, the stream can be divided into a number of vertical sections and the average velocity in each section is approximately determined. Then the mean velocity of flow in the cross-section is found by the expression.

$$\frac{\sum_{j=1}^n a_j v_j}{\sum_{j=1}^n a_j} \quad (25.19)$$

Where a_j is the area of the individual vertical section and v_j is the average velocity in that section.

25.2.2.2 FLOAT MEASUREMENTS

These are done in rectangular open channels or in manholes to determine approximately the velocity of flow between the manholes. They can be surface, sub-surface or both. The surface velocities are found and the average velocity is computed approximately as 0.87 of surface velocity. Normally the discharge measurements vary by $\pm 5\%$ of the true discharges.

Subsurface floats consist of relatively large bodies slightly heavier than water, connected by line wires to surface floats of sufficient size to finish the necessary floatation, and carrying marking by which their course may be traced. The resistance of the upper float and connecting wire is generally negligible and hence the combined unit may be assumed to move with the velocity of water at the position of the submerged float.

25.2.2.3 PITOT TUBES

The pitot tubes which is very useful for clear liquids is not useful in sewer gaugings because of the presence of suspended matter in wastewater which tends to clog the tube.

25.2.2.4 CHEMICAL AND RADIOACTIVE TRACERS

Where velocity measurements are to be made, the chemical or radioactive tracers are usually injected into the stream on the upstream side of the two control points. The time of passage of the prism of water containing the tracer is noted at these control points and the velocity computed as the distance between control points divided by the travel time. Where salt is used, as the tracer, the time of passage between control points is measured using electrodes connected to an ammeter or recorder. When the radioactive tracers are used, the time of passage is noted by radioactive counters attached to the outline of the pipe.

25.2.2.5 DYE TRACERS

These are successfully used for measuring the velocity of flow in small sewers.

25.2.2.6 CONCLUSION

The several types of flow measurement devices available for determining wastewater flows and their application and evaluation are summarised and presented in Tables 25.1 to 25.4. The suggested BIS codes on flow measurement are presented in Appendix C.

CHAPTER 26

EMERGING TECHNOLOGIES FOR SEWAGE TREATMENT

26.1 PREAMBLE

Domestic wastewater constitutes a major source of pollution especially of aquatic bodies as wastewaters generated in urban communities are discharged either without or with partial treatment. Though several factors are responsible for inadequate treatment facilities, the primary constraints are paucity of financial resources, high energy inputs required for some treatment technologies e.g. Activated Sludge Process and Extended Aeration Systems (12 - 20 kWh/person/year) and low or insignificant return on capital investments to build treatment plant facilities. To overcome these limitations of currently practised sewage treatment technologies, researches have been carried out to develop alternative technologies. Some of these emerging technologies include :

- i) Duckweed - Pond Technology
- ii) Vermi Culture Technology
- iii) Technology utilising raw sewage for forestry
- iv) Artificial wet Lands / Root Zone Technology

These technologies are based on natural systems of waste management and treatment. They possess the following distinct advantages.

- i) Minimum use of mechanical equipment
- ii) More Eco - Friendly
- iii) Capable of generating revenue

26.2 DUCKWEED POND TECHNOLOGY

26.2.1 General

The wastewater treatment employing duckweed pond system is relatively simple to construct, operate and maintain. Duckweed (Lemnaceae) is an aquatic plant which can grow prolifically when temperatures range between 15°C and 30°C, doubling its weight within 2 - 4 days. It requires basically nitrogen, phosphorus and potassium for growth. The duckweed yield can be quite high around 1 tonne per hectare per day. It can be used as cheap and high quality (high protein) animal feed, valuable protein component of chicken feed and feed for fish. Field trials in Bangladesh have indicated that the yield of fish fed on duckweed can be over 10 tonnes/ha/year

26.2.2 Process

It is claimed that duckweed pond system can be effective in meeting secondary or advanced tertiary treatment standards. The duckweed pond is an earthen basin, preferably lined, where duckweed plant grows and covers the entire water surface. Since this floating aquatic plant is very small, the duckweed is only a few millimetres in size, it can be easily swept off from the water surface to one side by wind or waves. Therefore, a floating grid system of plastic, bamboo or any other suitable material has to be installed to ensure quiescent conditions allowing duckweed to maintain a uniform cover over the entire pond surface. Such a uniform cover of duckweed cuts off penetration of sunlight into the water thereby eliminating growth of algae and aquatic plants which could have consumed the nutrients. Duckweed cover is also effective in suppressing odours and eliminating mosquito breeding. The excess duckweed biomass should be regularly harvested. The fresh duckweed can be introduced into separate fish pond to grow fishes like tilapia, carp, Rohu, Mrigel etc. The duckweed can also be dried or converted into pellets for use as feed for chicken and cattle.

In the duckweed pond, both anaerobic reactions and the activity of duckweed are responsible for removal of carbonaceous matter as well as nutrients and trace metals, if any. Except for a few cms of top layers where duckweed cover exists, the remaining depth of pond is anaerobic in nature

26.2.3 Process Flowsheet

A possible flowsheet for domestic wastewater treatment consists of the unit operations and processes of screening, grit removal, anaerobic treatment, removal of residual organic and nutrients (nitrogen and phosphorus) in a duckweed pond and harvesting/utilisation of duckweed either as animal feed, poultry feed or fish feed. Anaerobic treatment can be avoided by resorting to dilution or substituting it by sedimentation to reduce the BOD of sewage to about 100 mg/l.

26.2.4 Research and Development Needs

Research is required to determine the range of recommended values of hydraulic residence time and other parameters for duckweed pond. Presently the detention periods have ranged from 21 to 28 days. The depth of ponds may vary from 1.5

to 3.0 m. The duckweed pond not only removes the organics and nutrients (N,P) but is also capable of reducing the concentrations of chlorides, potassium, calcium, magnesium and trace metals, if any. There is no literature yet available on the efficiency of duckweed ponds to remove helminths, bacteria and pathogenic organisms. Research is also needed to evaluate whether any health hazards are posed by use of duckweed in food chain, through fish, poultry and animals.

26.3 VERMICULTURE TECHNOLOGY

26.3.1 General

This technology utilises earthworms for the treatment of domestic wastewater. The earthworms have been called as natural bioreactors. The earthworms produce both microorganisms and enzymes that breakdown complex bio-molecules into simple compounds which are utilised by the micro organisms. The earthworms feed on wastes and grind large size waste particles into smaller sizes down to 2 - 4 microns which can be utilised by microbial population residing inside the earthworms. It is claimed that aerobic conditions are maintained by virtue of its haemoglobin with high saturation constant and therefore no external aeration may be required. The earthworms produce vermicastings with immobilised microflora and nutrients. Vermicastings have the potential of being used as biofertilisers.

26.3.2 Process Description

The Vermiculture technology for treatment of domestic waste water is still in developmental stage. Preliminary studies conducted by a group in India indicate that for treatment of 1 mld of sewage, 2 filters of 1000 m² are required. Each filter contains 90 cm layer of active biomass of earthworms supported on sand and coarse aggregate. The sewage is distributed on the earthworm layer which extracts the contaminants and partially treated sewage is collected from the first filter and applied to second filter in series containing earthworms, sand and coarse aggregate. This two stage serial treatment is claimed to be free from odour and fly nuisance.

26.3.3 Research and Development Needs

This technology has the advantages of requiring no energy for aeration, no mechanical equipment for aeration and simple to operate and maintain. It is environmental friendly.

Before being applied in the field for treatment of sewage, it is necessary to undertake extensive pilot-scale and field experiments to develop sound engineering base for design, operation and maintenance of units employed in vermiculture technology. Research is also needed to establish the efficiency of removal of pathogens and helminths by this technology.

26.4 RAW SEWAGE FOR TREE PLANTATION

A method has been tried in India involving forestry, wherein water logging and stagnation have been controlled by utilising the irrigation and nutrient potential of raw sewage. In a research pilot study, one meter wide, 50 cm high ridges have been formed with 2 meter wide furrows. The soil of the experimental field was alluvial in nature with a pH around 8.6 and EC of 0.36 dSm⁻¹. Tree species such as eucalyptus, leucaena and poplar which can grow fast, transpire huge quantity of sewage, and at the same time are able to withstand high moisture content in the root environment have been planted on the ridges. Raw sewage is discharged through a feeding channel into furrows @ 0.5 mld per hectare. The amount of sewage to be applied in the system depends upon the age and type of plant, climatic conditions, soil texture and quality of the effluent. Total discharge of the effluent is so regulated that the same is consumed within 12 to 18 hours leaving no standing liquid in the furrows. It is possible to apply about 0.3 to 1 million litres of effluent per day per hectare under different conditions. Each tree acts as a small bio-pump absorbing liquid through the surrounding soil and releasing it to the environment through transpiration. This technique utilises the entire bio-system as "living filter" for supply of nutrients to soil plants and thus builds up soil fertility with respect to available N, P, K and micro nutrients. It also decreases the soil pH from highly alkaline to neutral levels without significantly building up of salinity. During the study it has been observed that the pH of the soil receiving sewage dropped from 8.4 to 7.4 in 4 years. Since these forest plants are to be used as firewood, timber and pulp, there is no chance of pathogens, heavy metals and toxic elements entering the human food-chain system. Though three different species of trees have been grown, the study revealed that eucalyptus seems to be the best choice.

Expenditure involved in adopting this technique is not much. Recurring cost for channelising the sewage effluent and maintenance of ridges etc., may be about four man days for 2.5 hectare per day. Another important positive aspect of this system is generation of revenue through sale of these trees from time to time for various purposes.

Though the aforesaid technique appears to be relatively cheaper involving less capital and recurring cost, same cannot be adopted as an independent method of sewage disposal in urban areas due to:

- a) lack of adequate waste land in and around cities and towns
- b) possibility of ground water and surface water contamination during non-irrigation period such as rainy season, as sewage effluent is not required by the plants
- c) difficulty in controlling odour and fly and mosquito breeding problems in the vicinity of urban areas due to stagnation of effluent
- d) possible leaching of pollutants into ground water which are accumulated in the furrows

- e) high ground water level in some areas
- f) possible health hazard to farm workers.

More research is required to make this technology applicable on commercial scale keeping in view the aforesaid limitations.

26.5 ROOT ZONE TECHNOLOGY

The root zone technology also referred to as artificial or constructed wetland system, is basically a man made wetland where wastewater is kept at or above the soil surface for enough time during the year to maintain saturated conditions and appropriate vegetation. The three essential components of the system include the soil, the appropriate vegetation such as reeds, cattails, bulrushes and sedges and the microbial organisms. The system has been used in Europe and U.S.A. for treatment of industrial wastewaters including effluents from textile plant containing over 250 organic chemicals, ammonia liquor from a steel industry and acid mine drainage. COD reductions of 84% have been reported from textile plant effluent with COD around 1500 mg/l at hydraulic residence time of 28 days.

26.5.1. Process

The root zone technology employing reeds growing a specially designed swamp (wetland) depends basically on the principle that reeds have an oxygen transport system from the leaves to the roots that permits the roots to survive in the anoxic conditions prevailing in a swamp. The oxygen supplied to the hollow roots called rhizomes is available to the aerobic bacteria growing in wastewater. The aerobic bacteria breakdown the organic matter present in the wastewater in a manner similar to that prevailing in a conventional aerated lagoon. It is claimed that there is greater diversity of microorganisms compared to that obtainable in a conventional treatment system.

The wetland plants used include reeds of the species phragmites which is common to every climate and continent on earth, cattails, bulrushes and sedges. The wastewater is pumped directly into the upper end of the reed bed surrounded by impermeable walls. The reed bed may require considerable time, several months, to grow and develop root system to achieve full treatment efficiency. The land requirements are quite large.

The principal merits of the system include

•

- i) No requirement of energy and mechanical equipment for aeration
- ii) Self regeneration of reed bed and virtually maintenance free
- iii) System can provide natural habitat for fauna.

26.5.2 Research and Development Needs

It is necessary to evolve sound design criteria and other parameters that affect system performance by undertaking both laboratory and field research and development work. The removal of helminths and pathogens by root zone technology needs to be studied.

26.6 CONCLUSION

It is recommended that detailed studies as recommended in the relevant sections should be conducted to evolve sound design parameters before application in the field, with due consideration to economical and environmental impact aspects.

APPENDIX - 'A'
ABBREVIATIONS AND SYMBOLS

AC	asbestos cement	lpcd	litre per capita per day
amp	ampere	lpd	litre per day
AS	activated sludge	lpm	litre per minute
BOD	biochemical oxygen demand	lps	litre per second
BOD ₅	5 days biochemical oxygen demand	m	metre
cc	cubic centimetre	mps	metre per second
CI	cast iron	m ²	square metre
cm	centimetre	m ³	cubic metre
CM	cement mortar	meq	milliequivalent
COD	chemical oxygen demand	min	minute
cumec	cubic metre per second	ml	millilitre
°C	degrees centigrade	d	day
mld	million litres per day	MLSS	mixed liquor suspended solids
DO	dissolved oxygen	MLVSS	mixed liquor volatile suspended solids
Eq or Eqn	equation	mm	millimetre
FAR	floor space index	MWL	maximum water level
F/M	food to micro organisms ratio	NPSH	net positive suction head
gm	gramme	ORP	oxidation reduction potential
GI	galvanised iron	Pr	primary
ha	hectare	PSS	percent soluble sodium
h, hr	hour	PVC	polyvinyl chloride
HRT	hydraulic retention time	RCC	reinforced cement concrete
HSV	hydraulic subsidence value	rph	revolution per hour
IS	Indian standard	rpm	revolution per minute
kcal	kilo calorie	SAR	sodium absorption ratio
kg	kilogram	SS	suspended solids
kgf	kilogram force	S.S.T	secondary sedimentation tank
kL	kilo litre	SVI	sludge volume index
kLD	kilo litre per day	T	tonnes
km	kilometre	TF	trickling filter
w	watt	TKN	total kjeldahl nitrogen
kw	kilowatt	VS	volatile solids
kwh	kilowatt hour	VSS	volatile suspended solids
l	litre		

APPENDIX - 'B'
CONVERSION FACTORS

Length			Volume		
1 in	= 25.4	mm	1 cu in	= 16.8871	cu cm
1 ft	= 0.3048	m	1 cu ft	= 0.0283	cu m
1 yd	= 0.9144	m	1 cu yd	= 0.7646	cu m
1 mile	= 1.6093	km	1 acre ft	= 1233.48	cu m
1 mm	= 0.0394	in	1 cu cm	= 0.061024	cu in
1 cm	= 0.3934	in	1 cu m	= 35.815	cu ft
	= 0.0328	ft		= 1.60795	cu yd
1 m	= 3.2808	ft		= 0.00081071	acre ft
1 m	= 1.0936	yd	Weight		
1 km	= 0.6214	mile	1 grain	= 0.0648	g
Area			1 oz	= 28.3495	g
1 sq in	= 645.163	sq mm	1 lb	= 0.4536	kg
	= 6.4516	sq cm	1 ton	= 1 01605	tonnes
1 sq ft	= 0.0929	sq m	1 g	= 15.45254	grains
1 sq yd	= 0.8361	sq m		= 0.0352740	oz
1 sq mile	= 2.59	sq km	1 kg	= 2.20462	lb
1 acre	= 0.4047	ha	1 tonne	= 0.98421	ton
	= 4046.86	sq m	Density		
1 sq mm ²	= 0.00155	sq in	1 lb/ft ³	= 16.0185	kg/m ³ or g/l
1 sq cm	= 0.1550	sq in	1 Kg/m ³	= 0.0624	lb/ft ³
1 sq m	= 10.7639	sq ft			
	= 1.1960	sq yd			
1 ha	= 2.4710	acre			
	= 0.00386	sq mile			
1 sq km	= 0.3861	sq mile			
	= 247.105	acre			

Capacity		Pressure and Stress			
1 gal (UK)	= 4.54609	l	1 lb/in ²	= 0.0703	kg/cm ²
	= 0.00454609	cu m	1 lb/ft ²	= 4.88243	kg/m ²
	= 0.160544	cu ft	1 ton/in ²	= 1.5749	kg/mm ²
1 gal (US)	= 0.00378541	cu m	1 atm	= 101325.0	N/m ²
	= 3.78533	l		= 760.0	mm Hg
	= 0.832675	UK gal		= 1.01325	bar
	= 0.133681	cu ft		= 14.6959	lbf/in ²
1 US Pint (Liquid)	= 0.4732	l		= 33.8984	ft H ₂ O
1 fluid oz (US)	= 29.5729	ml		= 29.9213	in Hg
1 fluid oz (UK)	= 28.4123	ml		= 10332.2	kg/m ²
1 l	= 0.001308	cu yd		= 10.3322	m H ₂ O
	= 0.2200	gal (UK)	1 kg/cm ²	= 14.223	lb/in ²
	= 0.264172	gal (US)		= 10	m H ₂ O
	= 0.0353147	cu ft		= 0.96784	atm
Force					
1 lbf	= 4.44822	N	1 kg/m ²	= 0.204816	lb/ft ²
	= 0.453592	kgf	1 kg/mm ²	= 0.6850	ton/in ²
1 tonf	= 9.96402	kN	1 atm	= 68087.0	pd/ft ² (where 1 pdl = 0.138255 N)
1 pdl	= 0.138255	N	1 mm Hg	= 2.78450	lb/ft ²
g (acceleration due to gravity)	= 32.1740	ft/sec ²	Energy and Power		
	= 980.665	cm/sec ²	1 horse-power	= 0.745700	kw
1 N (or 10 ⁵ dynes)	= 0.101972	kgf			
	= 0.224809	lbf	1 Blu	= 1.05506	kJ
1 kgf	= 2.20462	lbf	1 therm	= 105.506	MJ
Run-off			1 ft.lbf	= 1.35582	J
1 ft ³ /s/1,000 acre	= 6.99724	l/s/km ²	1 kw	= 1.34102	Horse-power
1 ft ³ /s/mile ²	= 10.9332	l/s/km ²	1 kwh	= 3.6	MJ
l/s/km ²	= 0.142915	1 ft ³ /s/1,000 acre	1 J	= 0.737562	ft lbf
	= 0.0914645	ft ³ /s/mile ²	1 kJ	= 0.277778	wh
			1 ft.lbf/s	= 1.35582	w

Velocity			Hardness		
1 fps	= 0.0348	m/s	mg/l CaCO ₃	Grains per UK gal CaCO ₃ (Clark scale- British degrees)	Grains per US gal CaCO ₃ (American degrees)
	= 1.0973	km/h			
1 mile/h	= 0.4470	m/s	1.00	0.07	0.058
	= 1.6093	km/h	14.29	1.00	0.83
1 m/s	= 3.2808	fps	17.15	1.20	1.00
	= 2.2369	mile/h	10.00	0.70	0.58
1 km/h	= 0.9113	fps	17.86	1.25	1.04
	= 0.6214	mile/h	2.57	0.18	0.15
Treatment Loading Rates			Parts per 100,000 CaCO ₃ (French degrees)	Parts per 100,000 CaO (German degrees)	Parts per million Ca (Russian degrees)
1 in/h	= 0.00705555	mm/s			
1 UK gal/ft ² h	= 0.0135927	mm/s	0.10	0.056	0.40
1 UK gal/ft ² h	= 1.17441	m ³ /m ² /d	1.43	0.80	5.72
1 million UK gal/acre/d	= 0.0130016	mm/s	1.72	0.96	8.86
	= 1.12336	m ³ /m ² /d	1.00	0.56	4.00
1 UK gal/day/ft	= 14.915	lpd/m	1.79	1.00	7.14
	= 0.014915	m ³ /day/m	0.26	0.14	1.03
1 US gal/ft ² h	= 0.011380	mm/s			
1 US gal/ft ² h	= 0.977879	m ³ /m ² /d			
1 million US gal/acre/d	= 0.0108258	mm/s			
1 US gal/day/ft	= 12.915	lpd/m			
	= 0.0124191	m ³ /day/m			
1 mm/s	= 141.732	in/h			
	= 73.5689	UK gal/ft ² /h			
	= 76.9130	million UK gal/acre/d			
1 m ³ /m ² /d	= 0.85149	UK gal/ft ² /h			
	= 0.890187	million UK gal/acre/d			
1 m ³ /day/m	= 67.466	UK gal/ day/ft			

APPENDIX C

LIST OF INDIAN STANDARDS RELATING TO
SEWERAGE AND SEWAGE TREATMENT

Indian Standard No.	Title
	General
SP 7:1983	National Building code of Indian 1983 - part IX Plumbing Services - Drainage and Sanitation.
SP 35:1987	Handbook on Water Supply and Drainage with special emphasis on plumbing.
IS 456:1978	Code of practice for plain and reinforced concrete (third revision)
IS 457:1957	Code of practice for general construction of plain and reinforced concrete for dams and other massive structures.
IS 460(PT 1):1985	Specification for test sieves: Part I wire cloth test sieves (third revision)
IS 460(PT 2):1985	Specification for test sieves:Part II Perforated plate test sieves (third revision)
IS 460(PT 3):1985	Specification for test sieves:part III methods of examination of apertures of test sieves (third revision)
IS 962:1967	Code of practice for architectural and building drawings (first revision)
IS 1200(PT 16):1979	Method of measurement of building and civil engineering works - Part 16 laying of water and sewer lines including appurtenant items (third revision)
IS 1200(PT 19):1981	Method of measurement of building and civil engineering works Part 19 water supply, plumbing and drains (third revision)
IS 1343:1980	Code of practice for prestressed concrete (first revision)
IS 1495:1970	Specification of mild steel dust-bins (first revision)
IS 1554	PVC insulated (heavy duty) electric cables
(a) part I - 1964	For working voltage upto and including 1100 volts
(b) part II - 1970	For working voltage from 3.3 KV upto and including 11 KV
IS 1607 : 1977	Methods for test sieving (first revision)
IS 2064 : 1973	Code of practice for selections, installation and maintenance of sanitary appliances (First Revision)
IS 2174 : 1962	Specification for reinforced concrete dust bins
IS 2212 : 1962	Code of practice for brickwork.
IS 2431 : 1963	Steel wheel barrows (single wheel type)
IS 3370(PT 1):1965	Code of practice for complete structure for the storage of liquids, Part I General

requirements.

IS 3370(PT 2):1965	Code of practice for concrete structures for the storage of liquids : Part II reinforced concrete structures.
IS 3370(PT 3):1967	Code of practice for concrete structures for the storage of liquids : Part III Prestressed Concretes Structures.
IS 3370(PT 4):1967	Code of practice of concrete structures for the storage of liquids : Part 4 Design tables.
IS 3764: 1966	Safety code for excavation work
IS 3861 : 1975	Method of measurement of plinth, carpet and reatable area of buildings (first revision)
IS 4081 : 1986	Safety code for blasting and related drilling operations.
IS 4682(PT 1):1968	Code of practice of lining of vesses and equipment for chemical processes Part I Rubber lining.
IS 4682(PT 2):1969	Part 2 Glass Enamel lining
IS 4682(PT 3):1969	Part 3 Lead lining
IS 4682(PT 4):1969	Part 4 Plasticised PVC lining
IS 4682(PT 5):1970	Part 5 Epoxide resin lining
IS 4682(PT 6):1970	Part 6 Phenolic resin lining
IS 4682(PT 7):1974	Part 7 Corrosion and heat resistant metals
IS 4682(PT 8):1974	Part 8 Precious metal
IS 4682(PT 9):1974	Part 9 Titanium
IS 4682(PT 10):1974	Part 10 Brick and tile
IS 4854(PT 1):1969	Glossary of terms for valves and their parts . Part 1 Screw down stop check and gate valve and their parts
IS 4854(PT 2):1969	Glossary of terms of valves and their parts: Part 2 Plug valves and cocks and their parts.
IS 4883 : 1988	Specification for sewer bricks (first revision)
IS 4926 : 1976	Specification for ready mixed concrete (first revision)
IS 5421 : 1981	Glossary of terms relating to test sieves and test sieving (first revision)
IS 5742(PT 1):1970	Terms and symbols for sieve bottoms : Part I Woven and Welded wire screens
IS 5742(PT 2):1970	Terms and symbols for sieve bottoms : Part II Perforated Plates.
IS 7331 : 1981	Code of practice for inspection and maintenance of cross-drainage works (first revision)
IS 7357 : 1974	Code of practice for structural design of surge tanks.
IS 7784(PT 1):1975	Code of practice for design and cross drainage work : part I General features
IS 7784(PT 2/SEC 1): 1983	Code of practice for design of cross drainage works : Part 2 Specific requirements section 1 Aqueducts.
IS 7784(PT 2/SEC 2): 1980	Code of practice for design of cross drainage works : Part 2 specific requirements section

	2 superpassages.
IS 7784(PT 2/SEC 3): 1981	Code of practice for design of cross drainage works : Part 2 Specific requirements section 3 Canal syphons
IS 7784(PT 2/SEC 4): 1980	Code of practice for design of cross drainage works : part 2 Specific requirements section 4 Level Crossings.
IS 7784(PT 2/SEC 5): 1980	Code of practice for design of cross drainage works Part 2 specific requirements Section 5 Syphon aqueducts
IS 7861 (PT 1):1975	Code of practice for extreme weather concreting part 1 Recommended practice for hot weather concreting
IS 7861 (PT 2):1981	Code of practice for extreme weather concreting : Part II Recommended practice for cold weather concreting.
IS 7969 : 1975	Safety code for handling and storage of building materials
IS 9913 : 1981	Code of practice for construction of cross drainage works
IS 10262 : 1982	Recommended guidelines for concrete mix design.
IS 10483 : 1983	Code for designating perforations of industrial plate sieves (identical with ISO/DIS 7806)
IS 11389 : 1986	Methods of test for performance of concrete vibrators Immersion type
IS 11993 : 1987	Code of practice for use of screen board concrete vibrators.
IS 12119 : 1987	General requirements for pan mixers for concrete
IS 12440 : 1988	Specification for precast concrete stone masonry blocks.
IS 12468 : 1988	General requirements for vibrators for mass concreting : Immersion type
IS 12592(PT 1):1988	Specification for precast concrete manhole covers and frames . Part I Covers

PIPES AND FITTINGS

1. GENERAL

IS 782 : 1979	Caulking lead (third revision)
IS 5382 : 1985	Rubber sealing rings for gas mains, water mains and sewers (first revision)
IS 6837 : 1973	Three wheel type pipe cutter (first revision)
IS 6843 : 1984	Technical supply conditions for pipe cutters (first revision)
IS 6881 : 1973	Link type pipe cutters
IS 10883 : 1984	Single wheel type pipe cutters
IS 11906 : 1986	Recommendations for cement-mortar lining for cast-iron, mild steel and ductile-iron pipes and fittings for transportation of water.
IS 12820 : 1989	Dimensional requirements for rubber gaskets for mechanical joints and bush joints for use with cast iron pipes water, gas and sewage.

2. CONCRETE

IS 458 : 1988	Concrete pipes (with and without reinforcement) (third revision)
IS 783 : 1985	Code of practice for laying of concrete pipes (first revision)
IS 784 : 1978	Prestressed concrete pipes (including fittings) (first revision)
IS 1916 : 1989	Steel cylinder reinforced concrete pipes (first revision)
IS 3597 : 1985	Methods of test for concrete pipes (first revision)
IS 7322 : 1985	Specials for steel cylinder reinforced concrete pipes (first revision)

3. ASBESTOS CEMENT

IS 1592 : 1989	Asbestos cement pressure pipes (third revision)
IS 5531 : 1988	Cast iron specials for asbestos cement pressure pipes for water, Gas and Sewage (second revision)
IS 5913 : 1989	Methods of test for asbestos cement products (first revision)
IS 6530 : 1972	Code of practice for laying of asbestos cement pressure pipes
IS 8794 : 1988	Cast iron detachable joints for use with asbestos cement pressure pipe (first revision)
IS 9627 : 1980	Asbestos cement pressure pipes (light duty)
IS 10292 : 1988	Dimensional requirement for rubber sealing rings for cast iron detachable joints in asbestos cement piping (first revision)
IS 10299 : 1982	Cast Iron saddle pieces for service connection for asbestos cement pressure pipes.
IS 11769 :	Guidelines for safe use of products containing asbestos
Part 1 : 1986	Asbestos cement products
IS 12987 : 1990	Cast Iron detachable joints for use with asbestos cement pressure pipes (light duty)
IS 12988 : 1990	Dimensional requirements for rubber sealing rings for CID joints in asbestos cement piping for light duty AC Pipes

4 CAST IRON PIPES

IS 1230 : 1979	Cast iron rain water pipes and fittings (second revision)
IS 1536 : 1989	Centrifugally cast (spun) iron pressure pipe for water, gas and sewage (second revision)
IS 1537 : 1976	Vertically cast iron pressure pipes for water, gas and sewage (first revision)
IS 1538(P1):1976	General requirements
IS 1538(P2):1976	Specific requirements for sockets and spigots of pipes
IS 1538(P3):1976	Specific requirements for sockets of fittings.
IS 1538(P4):1976	Specific requirements for flanges of pipes and fittings.
IS 1538(P5):1976	Specific requirements for raised flanges.
IS 1538(P6):1976	Specific requirements for standard flange drilling of flanged pipes and fittings.

IS 1538(PT 7):1976	Specific requirements for flanged sockets
IS 1538(PT 8):1976	Specific requirements for flanged spigots
IS 1538(PT 9):1976	Specific requirements for collars.
IS 1538(PT 10):1976	Specific requirements for double socket bends.
IS 1538(PT 11):1976	Specific requirements for tees all sockets.
IS 1538(PT 12):1976	Specific requirements for double socket tee with flanged branch
IS 1538(PT 13):1976	Specific requirements for crosses, all sockets
IS 1538(PT 14):1984	Specific requirements for double socket tapers (third revision)
IS 1538(PT 15):1976	Specific requirements for caps
IS 1538(PT 16):1976	Specific requirements for plugs
IS 1538(PT 17):1976	Specific requirements for bell south pieces.
IS 1538(PT 18):1976	Specific requirements for double flanged bends.
IS 1538(PT 19):1976	Specific requirements for all flanged tees.
IS 1538(PT 20):1976	Specific requirements for all flanged crosses
IS 1538(PT 21):1976	Specific requirements for double flanged tapers.
IS 1538(PT 22):1976	Specific requirements for split puddle or body flanges
IS 1538(PT 23):1976	Specific requirements for blank flanges
IS 1538(PT 24):1984	Specific requirements for all flanged radial tees (second revision)
IS 1729 : 1979	Sand cast iron spigot and socket soil waste and ventilating pipes, fittings and accessories (first revision)
IS 1879 : 1987	Malleable cast iron pipe fittings (Second revision)
IS 3114 : 1985	Code of practice for laying of cast iron pipes (first revision)
IS 3486 : 1966	Cast iron spigot and socket drain pipes
IS 3516 : 1966	Cast iron pipe flanges and flanged fittings for petroleum industry
IS 3989 : 1984	Centrifugally cast (spun) iron spigot and socket soil, waste and ventilating pipes, fittings and accessories (second revision)
IS 6163 : 1978	Centrifugally cast (spun) iron low pressure pipes for water, gas and sewage (first revision)
IS 7181 : 1986	Horizontally cast iron double flanged pipes for water, gas and sewage (first revision)
IS 8329 : 1990	Centrifugally cast (spun) ductile iron pressure pipes for water, gas and sewage (first revision)
IS 9523 : 1980	Ductile iron fittings for pressure pipes for water, gas and sewage
IS 11606 : 1986	Methods of sampling of cast iron pipes and fittings.
IS 12288 : 1987	Code of practice for use and laying of ductile iron pipes.

5. STEEL

IS 1239	Mild steel tubes, tubulars and other wrought steel fittings
** Part 1 - 1979 part 2 - 1982	Mild steel tubes (fourth revision) Mild steel tubulars and other wrought steel pipe fittings (third revision)
IS 1978 : 1982	Line pipe (second revision)
IS 3589 : 1991	Electrically welded steel pipes for water, gas and sewage (150 to 2000 mm nominal size) (second revision)
IS 5504 : 1969	Spiral welded pipes.
IS 5822 : 1986	Code of practice for laying of welded steel pipes for water supply (first revision)
IS 6392 : 1971	Steel pipe flanges
IS 6631 : 1971	Steel pipes for hydraulic purposes
IS 8062	Code of practice for cathodic protection of steel structures.

6. STONEWARE

651 : 1980	Salt glazed stoneware pipes and fittings (fourth revision)
3006 : 1979	Chemical resistant glazed stoneware pipes and fittings (first revision)
4127 : 1983	Code of practice for laying glazed stoneware pipes (first revision)

7. PLASTIC

IS 4984 : 1987	High density polyethylene pipes for potable water supplies, sewage and industrial effluents (third revision)
IS 7634	Code of practice for plastics pipe work for potable water supplies
Part 1 - 1975 Part 2 - 1975	Choice of materials and general recommendations Laying and jointing polyethylene (PE) pipes.
IS 8008	Specification for injection moulded HDPE fittings for potable water supplies
Part 1 - 1976 Part 2 - 1976 Part 3 - 1976 Part 4 - 1976 Part 5 - 1976 Part 6 - 1976 Part 7 - 1976	General requirements Specific requirements for 90 degree bends Specific requirements for 90 degree tees. Specific requirements for reducers Specific requirements for ferrule reducers. Specific requirements for pipe ends Specific requirements for sandwich flanges
IS 8360	Fabricated high density polyethylene (HDPE) fittings for potable water supplies.
Part 1 - 1977 Part 2 - 1977 Part 3 - 1977	General requirements Specific requirements for 90 degree tees. Specific requirements for 90 degree bends.
IS 12709 : 1989	Specification of glass fibre reinforced plastics (GRP) pipes for use for water supply and sewerage

PITCH IMPREGNATED FIBRE

IS 11925 : 1987 Specification for pitch-impregnated fibre pipes and fittings for drainage purposes

PUBLIC HEALTH AND SANITATION

Waste Water handling equipment

- IS 5600 : 1970 Sewage and Drainage pumps
- IS 6279 : 1971 Equipment for grit removal devices
- IS 6280 : 1971 Sewage screens
- IS 7232 : 1974 Method for imhoff cone test
- IS 8413 (PT 1):1977 Requirements for biological treatment equipment Part 1 Trickling filters.
- IS 8413 (PT 2):1982 Requirements for biological treatment equipment Part 2 Activated Sludge process and its modifications
- IS 9110 : 1979 Hand operated augers for cleaning water closet, pipes and sewer.
- IS 9213 : 1979 BOD Bottle
- IS 10037(P1):1981 Requirements for sludge dewatering equipment
Part 1 sludge drying beds-sand, gravel and underdrains
- IS 10037(P2):1983 Requirements for sludge dewatering equipment Part 2 Vacuum filtration equipment
- IS 10037(P3):1983 Requirements for sludge dewatering equipment Part 3 Centrifugal equipment (Solid bowl type)
- IS 10261 : 1982 Requirements for settling tank (clarifier equipment) for waste water
- IS 10552 : 1983 Buckets to be used in power driven buckets type sewer cleaning machine
- IS 105533 Requirements for Chlorination equipment
- Part 1 : 1983 General guidelines for chlorination plants including handling, storage and safety of chlorine cylinder and drums
- Part 2 : 1983 Vacuum feed type chlorinators
- Part 3 : 1983 Gravity feed type gaseous chlorinators
- IS 10595 : 1983 Requirements for power driven bucket-type sewer cleaning machine
- IS 11117 : 1984 Requirements for power driven rodding machine for sewers
- IS 11387 : 1985 Requirements for high pressure jetting machine for sewer cleaning
- IS 11397 : 1985 Attachment tools for power driven rodding machine

CODE OF PRACTICES

- IS 1172 : 1983 Code of basic requirements of water supply drainage and sanitation (third revision)
- IS 1742 : 1983 Code of practice for building drainage (Second revision)

IS 2470 (PT 1):1985	Code of practice for installation of septic tanks: Part 1 Design, criteria and construction (Second revision)
IS 2470 (PT 2):1985	Code of practice for installation of septic tanks : Part 2 secondary treatment and disposal of septic tank effluent (second revision)
IS 4111	Code of practice for ancillary structures sewerage system .
Part 1 : 1986	Manholes (first revision)
Part 2 : 1985	Flushing tanks (first revision)
Part 3 : 1985	Verted syphon (first revision)
Part 4 : 1968	Pumping stations and pumping mains (rising main).
IS 5329 : 1983	Code of practice for sanitary pipe work above ground for buildings (first revision)
IS 5611 : 1987	Code of practice for waste stabilization ponds (faculative type) (first revision)
IS 6295 : 1986	Code of practice for water supply and drainage in high attitudes and/or sub-zero temperature regions (first revision)
IS 6924 : 1973	Code of practice for the construction of refuse chutes in multistorey buildings
IS 7740 : 1985	Code of practice for road guillies (first revision)
IS 9872 : 1981	Specification for precast concrete septic tanks.
IS 12251 : 1987	Code of practice for drainage in basements.
IS 12314 : 1987	Code of practice for sanitation with leaching pit latrines in rural communities.
IS 11972 : 1987	Code of practice for safety precautions to be taken when entering a sewerage system

SOLID WASTES

Terminology

IS 9569 , 1980	Glossary of terms relating to solid wastes.
----------------	---

CODE OF PRACTICE

IS 10447 : 1983	Guidelines for utilization and disposal of solid waste from integrated steel plants.
IS 12625 : 1980	Solid wastes - Hospitals - Guidelines for management.
IS 12647 : 1989	Guidelines for collection equipments.
IS 12662(Pt 1):1989	Guidelines for optimization of use of vehicles for collection of municipal solid wastes : Part 1 Guidelines for selection of vehicles.

METHODS OF TEST

IS 9234 : 1979	Methods for preparation of solid waste sample for chemical and microbiological analysis.
IS 9235 : 1979	Methods for physical analysis and determination of moisture in solid wastes (excluding industrial wastes).
IS 10158 : 1982	Method of analysis of solid wastes (excluding industrial wastes)

WATER POLLUTION

Terminology

IS 7022 (PT 1):1973	Glossary of terms relating to water, sewage and industrial effluents, Part 1
IS 7022 (PT 2):1979	Glossary of terms relating to water, sewage and industrial effluents, Part 2
IS 10446 : 1983	Glossary of terms for water supply and sanitation.

Methods of sampling and Analysis

i) Sewage and industrial effluents

IS 2488 (PT 1):1966	Methods of sampling and test for industrial effluents, Part 1
IS 2488 (PT 2):1968	Methods of sampling and test for industrial effluents, Part 2
IS 2488 (PT 3):1968	Methods of sampling and test for industrial effluents, Part 3
IS 2488 (PT 4):1968	Methods of sampling and test for industrial effluents, Part 4
IS 2488 (PT 5): 1976	Methods of sampling and test for industrial effluents, Part 5
IS 4733 : 1971	Methods of sampling and test for sewage effluents, (first revision)
IS 6582 : 1971	Bio-assay methods for evaluating acute toxicity of industrial effluents and wastewaters.

ii) Waste Water

IS 1622 : 1981	Methods of sampling and microbiological examination of water (first revision)
IS 3025 : 1964	Methods of sampling and test (physical and chemical) for water used in industry.
IS 3025	Methods of sampling and test (physical and chemical) for water and wastewater.
(Part 1) : 1986	Sampling (first revision)
(Part 3) : 1987	Provision and accuracy test (first revision)
(Part 4) : 1983	Colour (first revision)
(Part 5) : 1983	Odour (first revision)
(Part 6) : 1983	Odour threshold (first revision)
(Part 7) : 1984	Taste threshold (first revision)
(Part 8) : 1984	Taste rating (first revision)
(Part 9) : 1984	Temperature (first revision)
(Part 10) : 1984	Turbidity (first revision)
(Part 11) : 1983	pH value (first revision)
(Part 12) : 1983	Density (first revision)
(Part 13) : 1983	Saturation index (with respect to calcium carbonate) (first revision)
(Part 14) : 1984	Specific conductance (wheatstone bridge, conductance cell) (first revision)

(Part 15) : 1984	Total residue (total solids dissolved and suspended) (first revision)
(Part 16) : 1984	Filterable residue (total dissolved solids) (first revision)
(Part 17) : 1984	Non-filterable residue (total suspended solid) (first revision)
(Part 18) : 1984	Volatile and fixed residue (total filterable and non-filterable) (first revision)
(Part 19) : 1984	Settleable matter (first revision)
(Part 20) : 1984	Dispersion characteristics (flow patterns) (first revision)
(Part 21) : 1983	Total hardness (first revision)
(Part 22) : 1986	Acidity (first revision)
(Part 23) : 1986	Alkalinity (first revision)
(Part 24) : 1986	Sulphates (first revision)
(Part 25) : 1986	Chlorine demand (first revision)
(Part 26) : 1986	Chlorine residual (first revision)
(Part 27) : 1986	Cyanide (first revision)
(Part 28) : 1986	Sulphite (first revision)
(Part 29) : 1986	Sulphide (first revision)
(Part 30) : 1988	Bromide (first revision)
(Part 31) : 1988	Phosphorus (first revision)
(Part 32) : 1988	Chloride (first revision)
(Part 33) : 1988	Iodide (first revision)
(Part 34) : 1988	Nitrogen (first revision)
(Part 35) : 1988	Silica (first revision)
(Part 36) : 1988	Ozone (first revision)
(Part 37) : 1988	Arsenic (first revision)
(Part 38) : 1989	Dissolved oxygen (first revision)
IS 3550 : 1965	Methods of test for routine control for water used in industry
Treatment and Disposal of industries effluents	
IS 4903 : 1979	Guide for treatment and disposal of effluents of cane sugar industry (first revision)
IS 5061 (PT 1):1978	Guide for treatment and disposal of effluents of pulp, paper and board industry part 1, For mills with chemical recovery systems (first revision)
IS 5183 : 1977	Guide for treatment and disposal of effluents of tanning industry (first revision)
IS 7453 : 1974	Guide for treatment of effluents of electroplating industry.

IS 7967 : 1976	Criteria for controlling pollution of marine costal areas.
IS 8032 : 1976	Guide for treatment and disposal of distillery effluents.
IS 8073 : 1976	Guide for treatment and disposal of steel plant effluents.
IS 8682 : 1977	Guide for treatment of effluents of dairy industry.
IS 9427 : 1980	Code of practice for operation and maintenance of deionizing columns.
IS 9508 : 1980	Guide for treatment and disposal of effluents of cotton and synthetic textile industry.
IS 9509 : 1980	Guide for treatment and disposal of effluents of viscose rayon industry.
IS 9841 : 1981	Guide for treatment and disposal of effluents of fertilizer industry.
IS 10044 : 1981	Guide for treatment and disposal of effluents of petroleum refinery industry.
IS 10495 : 1983	Guide for treatment and disposal of effluents of wool processing industry.

CHEMICAL HAZARDS

General

IS 1446 : 1985	Classification of dangerous goods.
IS 4155 : 1966	Glossary of terms relating to chemical and radiation hazards and hazardous chemicals.
Code of Safety	
IS 4209 : 1987	Chemical laboratories (First revision)
IS 4262 : 1967	Sulphuric acid.
IS 4263 : 1967	Chlorine
IS 4264 : 1967	Caustic soda
IS 4312 : 1967	Lead and its compounds
IS 4544 : 1968	Ammonia
IS 4560 : 1968	Nitric Acid
IS 4644 : 1968	Benzene, toluene and xylene.
IS 4906 : 1968	Radiochemical laboratory
IS 5184 : 1969	Hydrofluoric
IS 5208 : 1969	Acetic acid.
IS 5302 : 1969	Acetic anhydride
IS 5311 : 1969	Carbon Tetrachloride
IS 5685 : 1970	Carbon disulphide
IS 5931 : 1970	Handling of cryogenic liquids
IS 6156 : 1971	Chlorosulphonic acid

IS 6164 : 1971	Hydrochloric acid
IS 6269 : 1971	Ethylene oxide
IS 6270 : 1971	Phenol
IS 6818 : 1973	Phosphoric acid
IS 6819 : 1973	Calcium carbide
IS 6953 : 1973	Bromine
IS 6954 : 1973	Caustic potash
IS 7415 : 1974	Aniline
IS 7420 : 1974	Phthalic anhydride
IS 7444 : 1974	Methanol
IS 7445 : 1974	Acetone
IS 7812 : 1975	Mercury
IS 8185 : 1976	Phosgene
IS 8388 : 1977	Nitrobenzene
IS 9052 : 1978	Aluminium Chloride, anhydrous
IS 9053 : 1978	M-dinitrobenzene
IS 9277 : 1979	Monochlorobenzene
IS 9278 : 1979	Zinc Phosphide
IS 9279 : 1979	Aluminum Phosphide
IS 9679 : 1980	Work environmental monitoring (air borne contaminants)
IS 9744 : 1981	Thionyl chloride
IS 9785 : 1981	Aluminium alkyls
IS 9786 : 1981	Vinyl chloride monomer (VCM)
IS 9787 : 1981	Phosphoryl chloride
IS 10870 : 1984	Hexane
IS 10871 : 1984	Hydrazine and hydrazine hydrate
IS 10872 : 1984	Malathion
IS 10920 : 1984	Phosphorus trichloride
IS 11141 : 1984	Acrylonitrile
IS 12033 : 1986	Dinitro toluene
IS 12034 : 1986	Methyl bromide

IS 12035 : 1986	Microbiological laborator
IS 12141 : 1987	Methyle ethyle ketone
IS 12142 : 1987	1,1,1, trichloro ethane
IS 12413 : 1987	Tetrachloroethane

SANITARY APPLIANCES AND VALVES

IS 771 (PT 1):1979	Specification for glazed fire clay sanitary appliances : Part 1 General requirements.
IS 771 (PT 2):1985	Specification for glazed fire-clay sanitary appliances : Part 2 Specific requirements of kitchen and laboratory sinks (third revision)
IS 771(PT 3):1986	ISS for glazed fire-clay sanitary Part 3 specific requirements for urinals, Section 2 stall urinals.
IS 771(PT 3/SEC 1): 1979	Specification for glazed fire-clay sanitary appliances Part 3 specific requirements of urinals, section 1 slab urinals (Second revision).
IS 771(PT 3/SEC 2): 1985	Specification for glazed fire-clay sanitary appliances Part 3 specific requirements of urinals, section 2 stallurinals (thrid revision)
IS 771(PT 4):1979	Specification for glazed fire-clay sanitary appliances Part 4 specific requirements of postnorton slabs (Second revision)
IS 771(PT 5):1979	Specification for glazed fire-clay sanitary appliances Part 5 specific requirements of shower trays (Second revision).
IS 771(PT 6):1979	Specification for glazed fire-clay sanitary appliances Part 6 specific requirements of bed-pan sinks (Second revision).
IS 771(PT 7):1981	Specification for glazed fire-clay sanitary appliances Part 7 specific requirements of slope sinks (Second revision).
IS 772 : 1973	Specification for general requirements for enamelled cast iron sanitary appliances (Second revision).
IS 773 : 1988	Specification for enamelled cast iron water - closets railway coaching stock type (fourth revision).
IS 774 : 1984	Specification for flushing cistern for water closets and urinals (other than plastic cistern) (fourth revision).
IS 775 : 1970	Specification for cast iron brackets and supports for wash basins and sinks (second revision).
IS 780 : 1984	Specification for sluice vlves for water works purposes (50 to 300 mm size) (sixth revision)
IS 1703 : 1989	Specification for copper alloy float valves (Horizontal planger type) for water supply fitting (third revision)
IS 1726(PT 1):1974	Specification for cast iron manhole covers and frames Part 1 General requirements (second revision).
IS 1726(PT 2):1974	Specification for cast iron manhole covers and frames Part 2 specific requirements for HD double 1 circular type (second revision).
IS 1726(PT 3):1974	Specification for cast iron manhole covers and frames : Part 3 specific requirements for HD double triangular type (second revision).

IS 1726(Pt 4):1974	Specification for cast iron manhole covers and frames : Part 4 specific requirements of HD circular type (second revision).
IS 1726 (PT 5):1974	Specification for cast iron manhole covers and frames . Part 5 specific requirements for HD rectangular type (second revision).
IS 1726(Pt 6/SEC 1): 1974	Specification for cast iron manhole covers and frames : Part 6 specific requirements for LD rectangular type, section 1 single seal (second revision).
IS 1726(Pt 6/SEC 2): 1974	Specification for cast iron manhole covers and frames : Part 6 specific requirement of LD rectangular type, section 2 double seal (second revision).
IS 1726(Pt 7/SEC 1): 1974	Specification for cast iron manhole covers and frames : Part 7 specific requirement of LD square type, section 1 seal (second revision).
IS 1726(Pt 7/SEC 2): 1974	Specification for cast iron manhole covers and frames : Part 7 specific requirement of LD square type, section 2 Double seal (second revision)
IS 1726(Pt 8):1985	Specification for cast iron manhole covers and frames . part 8 specific requirements of HD square type.
IS 2084 : 1973	Code of practice for selection, installation and maintenance of sanitary appliances.
IS 2326:1987	Specification for automatic flushing cisterns for urinals (first revision).
IS 2548(Pt 1):1983	Specification for plastic seats and covers for water-closets Part 1 Thermoset seats and covers (fourth revision)
IS 2548(Pt 2):1983	Specification for plastic seats and covers for water-closets : Part 2 Thermoset seats and covers (fourth revision)
IS 2556(Pt 1):1974	Specification for vitreous sanitary appliances (vitreous china) Part 1 General requirements (Second revision).
IS 2556(Pt 2):1981	Specification for vitreous sanitary appliances (vitreous china) Part 2 specific requirements of wash down water-closets (third revision).
IS 2556(Pt 3):1981	Specification for vitreous sanitary appliances (vitreous china) : Part 3 Specific requirements of Squatting pans (third revision).
IS 2556(Pt 4):1972	Specification for vitreous sanitary appliances (vitreous china) : Part 4 Specific requirements of wash basins (second revision).
IS 2556(Pt 5):1979	Specification for vitreous sanitary appliances (vitreous china) : Part 5 Specific requirements of laboratory sinks (second revision)
IS 2556(Pt 6/SEC 1). 1979	Specification for vitreous sanitary appliances (vitreous china) : Part 6 Specific requirements of urinals, section 1 Bowl type (third revision)
IS 2556(Pt 6/SEC 2): 1974	Specification for vitreous sanitary appliances (vitreous china) : Part 6 Specific requirements of urinals, section 2 Half stall urinals (second revision).
IS 2556(Pt 6/SEC 3): 1974	Specification for vitreous sanitary appliances (vitreous china) : Part 6 Specific requirements of urinals, section 3 Squatting plate (second revision)
IS 2556(Pt 6/SEC 4): 1974	Specification for vitreous sanitary appliances (vitreous china) : Part 6 Specific requirements of urinals, section 4 partition slab (second revision)
IS 2556(Pt 6/SEC 5): 1974	Specification for vitreous sanitary appliances (vitreous china) . Part 6 Specific requirements of urinals, section 5 waste fittings (second revision)

IS 2556(PT 6/SEC 6): 1974	Specification for vitreous sanitary appliances (vitreous china) : Part 6 Specific requirements of urinals, section 6 water spreaders for half stall urinals (second revision).
IS 2556 (PT 7):1973	Specification for vitreous sanitary appliances (vitreous china) : Part 7 Specific requirements of half round channels (second revision).
IS 2556 (PT 8):1985	Specification for vitreous sanitary appliances (vitreous china) : Part 8 Specific requirements of siphonic wash-down water closets (third revision)
IS 2556 (PT 9):1979	Specification for vitreous sanitary appliances (vitreous china) : Part 9 Specific requirements of bidets (third revision)
IS 2556(PT 10):1974	Specification for vitreous sanitary appliances (vitreous china) Part 10 Specific requirements of foot rests (second revision).
IS 2556(PT 11):1979	Specification for vitreous sanitary appliances (vitreous china) : Part 11 Specific requirements of shower rose (first revision).
IS 2556(PT 12):1973	Specification for vitreous sanitary appliances (vitreous china) Part 12 Specific requirements of floor traps.
IS 2556(PT 13):1973	Specification for vitreous sanitary appliances (vitreous china) . Part 13 Specific requirements of traps for squatting pans
IS 2556(PT 14):1974	Specification for vitreous sanitary appliances (vitreous china) : Part 14 Specific requirements of intergrated squatting pans.
IS 2556(PT 15):1974	Specification for vitreous sanitary appliances (vitreous china) . Part 15 Specific requirements of universal water closets.
IS 2685 : 1971	Code of practice for selection, installation and maintenance of sluice valves (first revision).
IS 2906 : 1984	Specification for sluice valves for Water works purposes (350 to 1200 mm size) (third revision)
IS 2963 : 1979	Specification for copper alloy waste fittings for wash basins and sinks (first revision).
IS 3042 : 1965	Specification for single face sluice gates (200 to 1200 mm size)
IS 3311 : 1979	Specification for waste plug and its accessories for sinks and wash-basins (first revision)
IS 3489 : 1985	Specification for enamel steel bath tubes (first revision).
IS 3950 : 1979	Specification for surface boxes for sluice valves (first revision).
IS 4038 : 1986	Specification for foot valves for water works purposes (second revision).
IS 4346 : 1982	Specification for washers for use with fittings for water services (first revision).
IS 5219(PT 1):1969	Specification for cast copper alloys traps: part 1 'P' and 'S' traps.
IS 5312(PT 1):1984	Specification for swing check type reflux (non-return) valves Part 1 single door pattern (first revision)
IS 5312(PT 2):1986	Specification for swing check type reflux (non-return) valves . Part 2 Multi-door pattern.
IS 5434 : 1979	Specification for non-ferrous alloy bottle traps for marine use.
IS 5455 : 1969	Specification for cast-iron steps for manholes.
IS 5917 : 1970	Specification for vitreous (vitreous china) wash basins for marine use

IS 5961 : 1970	Specification for cast iron gratings for drainage purposes
IS 6411 : 1985	Specification for gel-coated glass fibre reinforce polyester resin bath tube (first revision).
IS 7231 : 1984	Specification for plastic flushing cisterns for water closets and urinals (first revision).
IS 8718 : 1978	Specification for vitreous enamelled steel kitchen sinks
IS 7819 : 1978	Specification for vitreous siphonic wash-down water closets for marine use
IS 8727 : 1978	Specification for vitreous enamelled steel wash basins.
IS 9076 : 1979	Specification for vitreous integrated squatting pans for marine use.
IS 9739 : 1981	Specification for pressure reducing valves for domestic water supply systems.
IS 9758 : 1981	Specification for flush water and fittings for water closets and urinals
IS 9762 : 1981	Specification for polyethylene floats for ball valves.
IS 11246 : 1985	Specification for glass fibre reinforced polyester resins (GRP) squatting pans
IS 12234 : 1988	Specification for plastic equilibrium float valves for cold water services.
IS 12701 : 1989	Specification for rotational moulded polyethylene water storage tanks.

FLUID FLOW MEASUREMENTS

IS 1192 : 1981	Velocity area methods for measurement of flow of water in open channels.
IS 2912 : 1964	Recommendations for liquid flow measurement in open channels by slope-area method (approximate method).
IS 2913 : 1964	Recommendations for determination of flow in tidal channels.
IS 2914 : 1964	Recommendations for estimation of discharge by establishing stage-discharge relation in open channels
IS 2952 (PT 1):1964	Recommendations for methods of measurement of liquid flow by means of orifice plates and nozzles : Part 1 incompressible fluids.
IS 2952 (PT 2):1975	Recommendations for methods of measurement of liquid flow by means of orifice plates and nozzles : Part 2 compressible fluids.
IS 4477 (PT 1):1967	Methods of measurement of fluid flow by means of venturi meters : Part 1 liquids.
IS 4477 (PT 2):1975	Methods of measurement of fluid flow by means of venturi meters : Part 2 compressible fluids
IS 6059 : 1971	Recommendations for liquid flow measurement in open channels by weirs and flumes - weirs of finite crest width for free discharge.
IS 6062 : 1971	Method of measurement of flow of water in open channels using standing wave flume - fall.
IS 6063 : 1971	Method of measurement of flow of water in open channels using standing wave flumes.
IS 6330 : 1971	Recommendation for liquid flow measurement in open channels by weirs and flumes - end depth method for estimation of flow in rectangular channels with a free overfall (approximate method)
IS 9108 : 1979	Liquid flow measurement in open channels using thin plate weirs.

IS 9115 : 1979	Method for estimation of incompressible fluid flow in closed conduits by bend meters
IS 9117 : 1979	Recommendation for liquid flow measurement in open channels by weirs and flumes - end depth method for estimation of flow in non- rectangular channels with a free overfall (approximate method).
IS 9119 : 1979	Method for flow estimation by jet characteristics (approximate method).
IS 9163 (PT 1):1979	Dilution methods of measurement of steady flow part 1 constant rate injection method.
IS 9922 : 1981	Guide for selection of method for measuring flow in open channels.
IS 12752 : 1988/ISO	Guidelines for the selection of flow gauging 8368-1985 structures

APPENDIX 1.1
TYPICAL PERFORMANCE CHARACTERISTICS FOR VARIOUS METHODS OF SEWAGE TREATMENT

Item	Extended Aeration	Conventional Activated Sludge	Conventional Trickling Filters	Facultative Aerated Lagoons	Anaerobic Aerobic Systems (a)	Waste Stabilization Ponds	Land Treatment
Performance (Typical)							
BOD removal, %	95 - 98	85 - 92	80 - 90	75 - 85	75 - 85	75 - 85	80 - 90
Nutrient removal, N	15 - 30(b)	30 - 40(b)	15 - 20	-	-	40 - 50	80 - 90
Nutrient removal, %P	10 - 20(b)	30 - 45(b)	10 - 20	-	-	20 - 60	90 - 99
Coliform removal, %	60 - 90	60 - 90	60 - 90	60 - 90	-	60 - 99.9	90 - 99
Helminth removal, %	-	-	-	-	Yes	Yes	-
Land requirement (m ² /person) (c)	0.15 - 0.20	0.18 - 0.25	0.20 - 0.30	0.30 - 0.40	0.15 - 0.20 (excluding post treatment)	2.0 - 2.8	1.0 - 2.0
Process Power Requirement (kWhr/person/year)(d)	16 - 19	12 - 15	7 - 11	12 - 15	Nil	Nil	Nil
Sludge Handling	No digestion. Dry on beds or use mech. devices	Digest then dry on beds or use mech. devices	Digest then dry on beds or use mech. devices	Manual desludging once in 5 to 10 years	Directly dry on beds or use mech. devices	Manual desludging once in 5 to 10 years	
Equipment Requirement (excluding screening and grit removal)	Aerators, Recycle Pumps, Sludge scrapers (for large settlers)	Aerators, Recycle Pumps, Scrapers, thickeners, Digesters, Dryers, Gas Equipment	Trickling filter arms, Recycle Pumps, Sludge Scrapers, Thickeners, Digesters, Gas Equipment	Aerators only	Nil (gas collection optional)	Nil	Sprinklers or Drip Irrigation (optional)
Operational Characteristics	Simpler than Activated sludge	Skilled Operation required	Skilled Operation required	Simple	Simpler than Activated Sludge	Simplest	
Effect of Population size on unit cost	Relatively little	Considerable	Considerable	Slight	Relatively little	Slight	Slight
Special Features	BOD removal highest, effluent nitrified, relatively high power requirement. Favoured for small and medium sized plants	Considerable equipment and skilled operation required, especially if gas collection and usage involved. Method considered mainly for largesized plants	Considerable equipment and skilled operation required, especially if gas collection and usage involved. Method has often been preferred in India for largesized plants owing to lower power requirement compared to Activated Sludge	Power requirement similar to Activated sludge but construction and operation very simple. Also easy to enlarge or relocate if necessary	Minimal to negligible power requirement of the system makes it an economical alternative if gas revenue is neglected. Land requirement is also relatively small but depends on type of post treatment adopted	Simplest treatment method and nil power requirement. But this advantage may be offset by high land requirement which may be unavailable or expensive near urban areas	Adequate pretreatment required depending on type of crops and distribution system used. Some O and M cost is offset by revenue from crops

a) System includes anaerobic treatment of whole raw waste in an aerobic unit followed by a 3 celled maturation pond of 6-7 days detention time. Also includes sludge drying beds. However efficiencies can be attained by suitable choice of post-treatment after the anaerobic step

b) Additional nutrient removal can be achieved through special measures

c) Based on population equivalent of 54 grams/person/day, 3 m depth of water in lagoons and embankment slopes about 2 horizontal: 1 vertical

d) Based on aerator capacity of 2 kg Oxygen/kW-hour at standard conditions (20 degree C, Zero D.O. and plain water) and 0.75 of standard value delivered at field conditions. Process power does not include initial raw sewage pumping in all cases

APPENDIX 1.2
ESTIMATION OF FUTURE POPULATION

PROBLEM:

The population of a town as per the Census records are given below for the years 1921 to 1981. Assuming that the scheme of water supply will commence to function from 1986, it is required to estimate the population 30 years hence i.e. in 2016 and also the intermediate population 15 years after 1986 i.e. 2001.

YEAR	POPULATION	INCREMENT
1921	40,185	---
1931	44,522	4,337
1941	60,395	15,873
1951	75,614	15,219
1961	98,886	23,272
1971	124,230	25,344
1981	158,800	34,570
Total:		118,615
Average:		19,769

SOLUTION:**1. ARITHMETICAL PROGRESSION METHOD**

Increase in population from 1921 to 1981		
i.e. in 6 decades		1,58,800
	(-)	40,185

		1,18,615

$$\text{or increase per decade} = 1/6 \times 118,615 = 19,769$$

$$\begin{aligned} \text{Population in 2001} &= \text{Population in 1981} + \text{Increase for 2 decades} \\ &= 158,800 + 2 \times 19,769 \\ &= 158,800 + 39,538 = 198,338 \end{aligned}$$

$$\begin{aligned} \text{Population in 2016} &= \text{Population in 1981} + \text{Increase for 3.5 decades} \\ &= 158,800 + 3.5 \times 19,769 = 227,992 \end{aligned}$$

2. GEOMETRICAL PROGRESSION METHOD

Rate of growth (r) per decade between

$$1931 \text{ and } 1921 = 4,337 / 40,185 = 0.108$$

$$1941 \text{ and } 1931 = 15,873 / 44,522 = 0.356$$

$$1951 \text{ and } 1941 = 15,219 / 60,395 = 0.252$$

$$1961 \text{ and } 1951 = 23,272 / 75,614 = 0.308$$

$$1971 \text{ and } 1961 = 25,344 / 98,886 = 0.256$$

$$1981 \text{ and } 1971 = 34,570 / 124,230 = 0.278$$

Geometric Mean,

$$r_g = \sqrt[6]{0.108 \times 0.356 \times 0.252 \times 0.308 \times 0.256 \times 0.278} = 0.2442$$

Assuming that the future growth follows the geometric mean for the period 1921 to 1981 $r_g = 0.2442$

$$\begin{aligned} \text{Population in 2001} &= \text{Population in 1981} \times (1 + r_g)^2 \\ &= 158,800 \times (1.2442)^2 = 2,45,800 \end{aligned}$$

$$\begin{aligned} \text{Population in 2016} &= \text{Population in 1981} \times (1 + r_g)^{3.5} \\ &= 158,800 \times (1.2442)^{3.5} = 3,05,700 \end{aligned}$$

APPENDIX 1.2

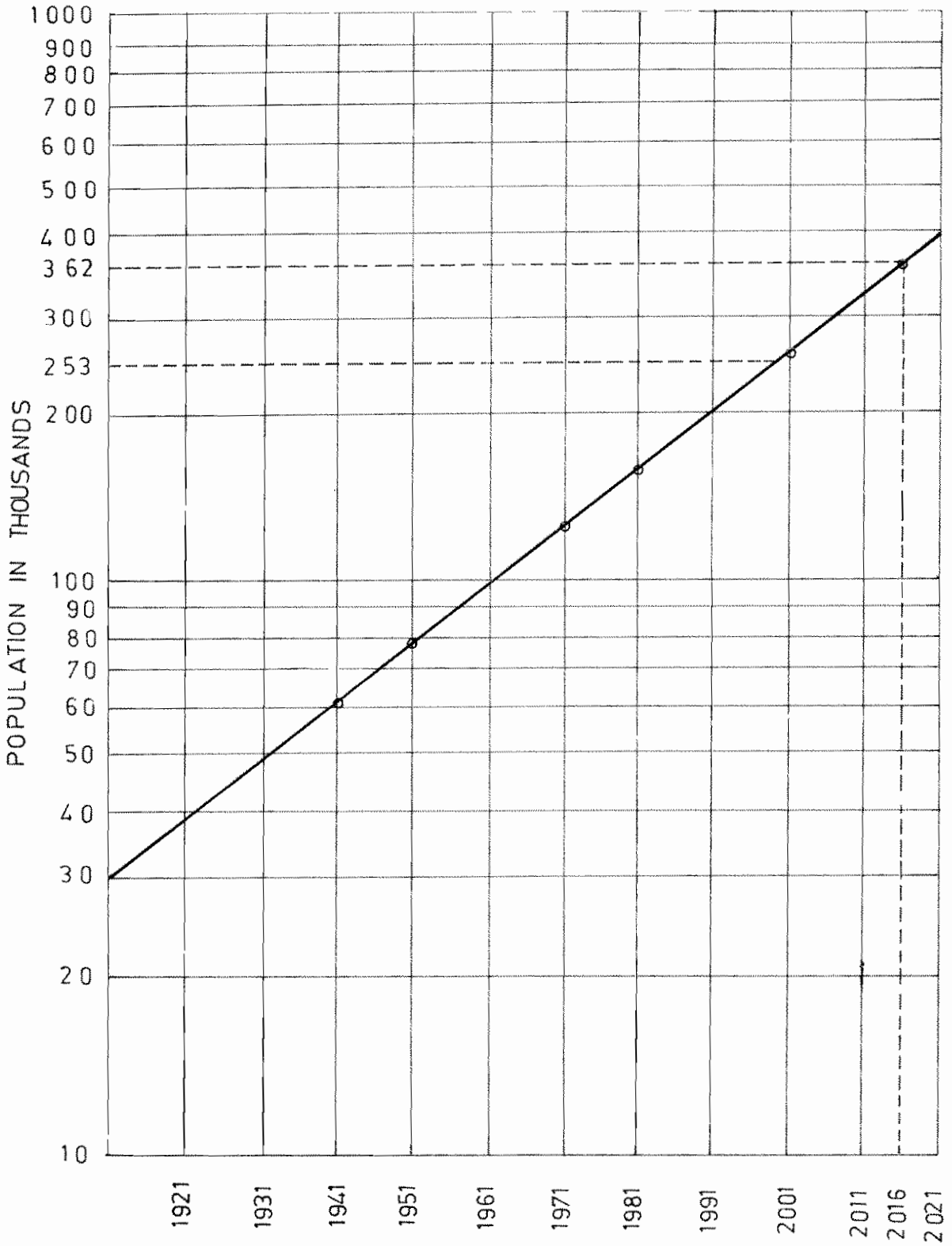

SEMI LOG GRAPH FOR ESTIMATION OF FUTURE POPULATION

3. METHOD OF VARYING INCREMENT OR INCREMENTAL INCREASE METHOD

In this method a progressively decreasing or increasing rather than a constant rate is adopted. This is a modification over the Arithmetical Progression method.

YEAR	POPULATION	INCREASE (X)		INCREMENTAL INCREASE (Y)
1921	40,185			
1931	44,522	4,337		
1941	60,395	15,873	+	11,536
1951	75,614	15,219	-	654
1961	98,886	23,272	+	8,053
1971	124,230	25,344	+	2,072
1981	158,800	34,570	+	9,226
	Total:	118,615		30,233
Average	=	$1/6 \times 118,615$	=	$1/5 \times 30,233$
	=	19,769	=	6,047

$$P_n = P_1 + nX + \frac{n(n-1)Y}{2}$$

$$P_{2001} = P_{1981} + 2 \times 19769 + \frac{2 \times 1 \times 6047}{2}$$

$$\text{Population in 2001} = 158,800 + 39,538 + 18,141 = 216,479$$

$$P_{2016} = P_{1981} + 3.5 \times 19769 + \frac{3.5 \times 4.5 \times 6047}{2}$$

$$\text{Population in 2016} = 158,800 + 69,192 + 24,188 = 252,180$$

4. GRAPHICAL PROJECTION METHOD

From the (Fig.1.2) presented on the following page, the figures for 2001 and 2016 years obtained are as follows:

2001 - 253,000

2016 - 362,000

APPENDIX 3.1

COMPUTATION OF STORM RUNOFF AND DESIGN OF STORM SEWER

Problem:

Design a system of storm sewers for the area shown in the figure No.1 based on the Rational Formula for the estimation of peak runoff.

Basic Data and Assumptions Imperviousness

Built up and paved area	-	0.7
Open space, lawns, etc.	-	0.2

Inlet time

Built up and paved area (t_b)	-	8 minutes.
Open space, lawns (t_s)	-	15 minutes.

Minimum velocity in sewer - 0.8 mps

Minimum depth of cover above crown - 0.5 metres.

Rainfall intensity = consider one year storm as the area is central and high priced.

(Use Table 3.1 for the record of rainfall intensity and frequency of rainfall).

Use Manning's chart for Sewer design.

Solution:

Quantity of storm water runoff is calculated using the Rational Formula given in Sec.3.3.1.

i.e. $Q = 10 \text{ c.i.A}$

Where,

Q =	runoff in m^3/hr
c =	coefficient of runoff
i =	intensity of rainfall in mm/hr and
A =	area of drainage district in hectares.

Storm water runoff is determined in the following manner;

- i) From the rainfall records for the last 26 years (table 3.1), the storm occurring once in a year, i.e. 26 times in 26 years, the time-intensity values for this frequency are obtained by inter-polation and are as follows:

Intensity, 'i' mm/hr	30	35	40	45	50	60
Duration, 't' minute	44	36	28.5	22.5	13.5	9.75

- ii) The generalised formula adopted for intensity and duration is



$$i = \frac{a}{t^n}$$

Where i = intensity of rainfall in mm/hr.
 t = duration in minutes and 'a' and 'n' are constants.

A graph (Fig.2) is plotted for one year storm using the values of 'i' and 't' from the above table on a log-log paper. From the line of best fit the values of 'a' and 'n' are found out. From the plotted line, values of 'a' and 'n' are 160 and 0.4 respectively.

- iii) Now using equation $i = (160 / t^{0.4})$, i.e. after substituting the values of 'a' and 'n' different values of i for various values of t are calculated and tabulated as below and a curve (Fig.3.a) is plotted on an ordinary graph paper.

Table for intensity-duration curve for one year storm:

t_{min}	5	10	15	20	25	30	35	40	45	60	80	100	120
$i = a/t^n$	84.2	64.0	54.0	48.5	44.2	41.2	38.6	36.8	34.8	31.0	27.8	25.4	23.6

- iv) Another graph [Fig.3(b)] of runoff-coefficient 'c' vs. duration time 't' is plotted as per values given in Table 3.2 (Horner's Table).
- v) From the above two graphs (Fig.3(a) and (b)) the values of c and i for the same duration time t are determined and the curves for 10 ci vs t for the various values of imperviousness are plotted (Fig.4). The value of 10 ci gives the rate of runoff in m^3/hr per hectare of the tributary area. These curves are ultimately used in calculating the runoff from the tributary areas for a given time of concentration and imperviousness factor.

Design of Storm Sewer System:

Table 1 gives the various components of the storm sewer system design.

Column 1-4 identify the location of drain, street and manholes.

Column 5-6 record the increment in tributary area with the given imperviousness factors.

Column 7 gives the tributary area increment with equivalent 100 percent imperviousness factor.

Column 8 records the total area served by each drain.

Column 9 records the time of concentration at each upper end of line (drain). The time of concentration is found by taking the weighted average of the two areas.

$$i.e. t_c = \frac{A_1 \cdot t_b + A_2 \cdot t_1}{A_1 + A_2}$$

Where

A_1 = built up area and
 A_2 = Area of lawns)

Column 10 records the time of flow in each drain. For example the time of flow in line 1 is calculated to be $70/(60 \times 1.0) = 1.17$ min.

Column 11 is the total time of concentration for each drain.

Column 12 is the value of runoff as 10 ci read from the Fig.4 for the corresponding time of concentration.

Column 13 gives the total runoff from each tributary area.

Column 14 gives the runoff in lps from each tributary area.

Column 15-18 record the chosen size, required grade resulting capacity, velocity of flow for each drain or line. These designs of storm sewers are computed from the Manning's chart for each required flow and maintaining a minimum velocity.

Column 19-23 identify the profile of the drain.

Column 19 is taken from the plan.

Column 20 = Col.19 x Col.16.

Column 21 the required drop in manholes is obtained directly from the recommended values in section 3.3.4.5.

Column 22 gives invert elevation at the upper end with a minimum cover of 0.6m at starting manhole. Thus for lines 1,3,6 and 9, the invert elevations are respectively 37.400, 36.700, 38.000 and 36.000. In case a manhole having more than one inlet, the drop in the manhole is considered with respect to the lowest invert level of the inlets to fix the invert level of the outlet.

Column 23 = Col.22-Col.20 = invert elevation at the lower end of the line.

TABLE 1
DESIGN OF STORM SEWER SYSTEM

Line Number	LOCATION OF DRAIN			TRIBUTARY AREA (HECTARES) INCREMENT			Total Area	to TIME OF CONCENTRATION			RUNOFF M3/hr		Flow 'Q'	DESIGN						PROFILE		
	Street	Manhole from	Manhole to	0.7 Imp factor	0.2 Imp factor	Eq 100% Imp factor		Time of inlet to upper end t _i	Time of Flow in Drain t _d	Total t _c = t _i +t _d	Per Hectare (10ci)	Total		lps	Dia mm	Slope m/1000	Capacity lps	Velocity mps	Length m	fall m	Drop in Manhole m	INVERT ELEVATION
1	2	3	4	5	6	7	8	9	10	11	12	13	14	15	16	17	18	19	20	21	22	23
1	South St	5	4	0.286	0.366	0.274	0.274	12.0	-	12.0	345	84.5	26.6	200	10.0	32	1.0	70	0.7	0.000	37.400	36.700
2		4	3	0.167	0.488	0.214	0.488	13.3	1.17	14.47	335	164.0	46.0	250	6.65	50	1.0	125	0.83	0.025	36.675	35.845
3	NorthSouth St2	R 3.2	R 3.1	0.415	0.312	0.352	0.352	11.0	-	11.0	348	123.0	35.0	250	6.65	50	1.0	70	0.47	0.000	36.700	36.230
4		R 3.1	3	0.358	0.36	0.324	0.676	11.5	1.17	12.67	340	264.0	74.0	350	4.55	98	1.0	70	0.32	0.050	36.180	35.860
5	South St	3	2	0.256	0.466	0.274	1.436	12.5	3.27	15.77	335	480.0	135.0	450	3.14	160	1.0	125	0.40	0.066	35.779	35.379
6	NorthSouth St3	R 2.2	R 2.1	0.230	0.492	0.260	0.260	12.8	-	12.8	340	87.5	25.0	200	10.0	32	1.0	70	0.70	0.000	38.000	37.300
7		R 2.1	2	0.410	0.310	0.348	0.608	11.0	1.17	12.17	342	208.0	59.0	300	5.55	70	1.0	70	0.39	0.050	37.250	36.860
8	South St	R 2	1	0.256	0.466	0.274	2.320	12.5	5.37	17.87	330	765.0	214.0	600	2.22	280	1.0	160	0.36	0.200	35.179	34.819
9	NorthSouth St4	R 1.2	R 1.1	0.660	0.282	0.517	0.517	10.2	-	10.2	350	182.0	51.0	250	10.0	60	1.25	70	0.70	0.000	36.800	36.100
10		R 1.1	1	0.580	0.362	0.479	0.996	10.8	0.94	11.74	344	330.0	92.0	350	5.0	100	1.1	70	0.35	0.050	36.050	35.700
11	South St	1	Pumphouse	0.670	0.330	0.494	3.810	10.4	8.05	18.45	325	1240.0	345.0	700	1.67	400	1.0	25	0.42	0.234	34.585	34.165

APPENDIX 3.1

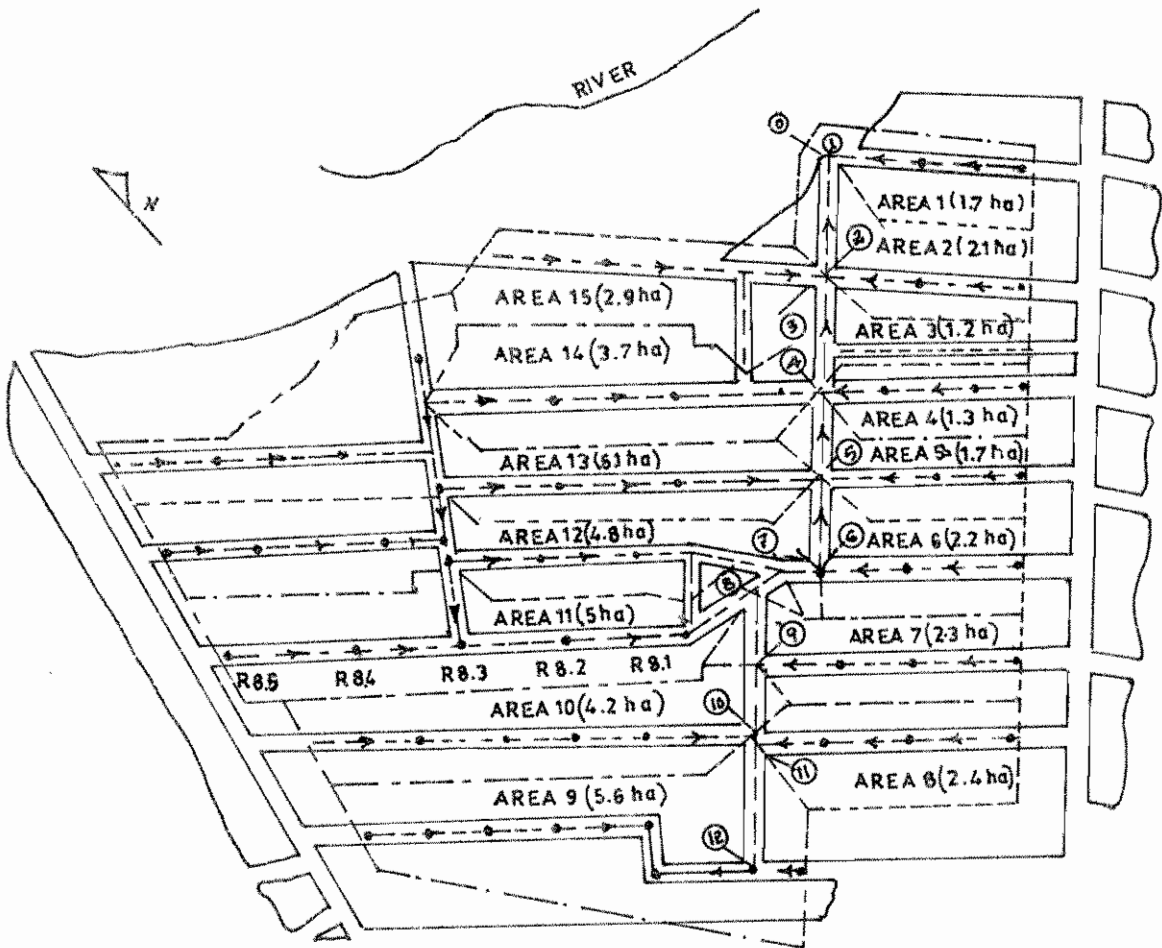

APPENDIX 3.1

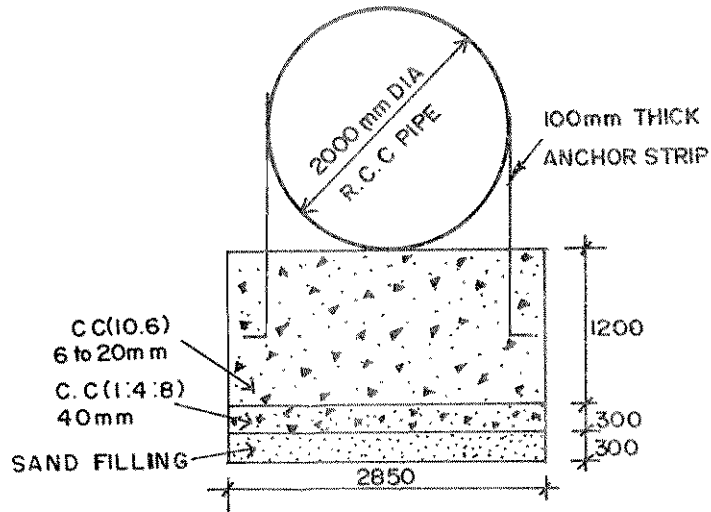

SECTION WITH OUT OVER BURDEN

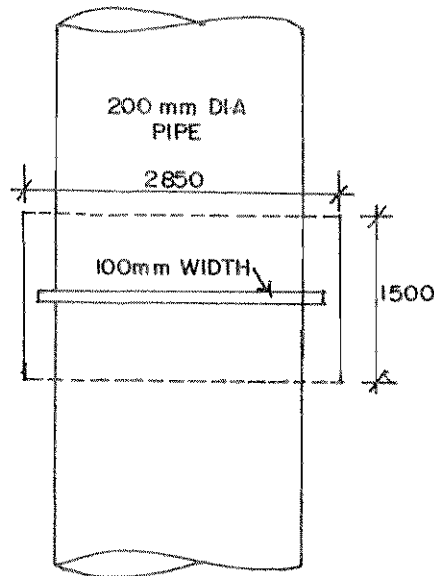

PLAN

ANTIFLOTATION BLOCK .

APPENDIX 3.1

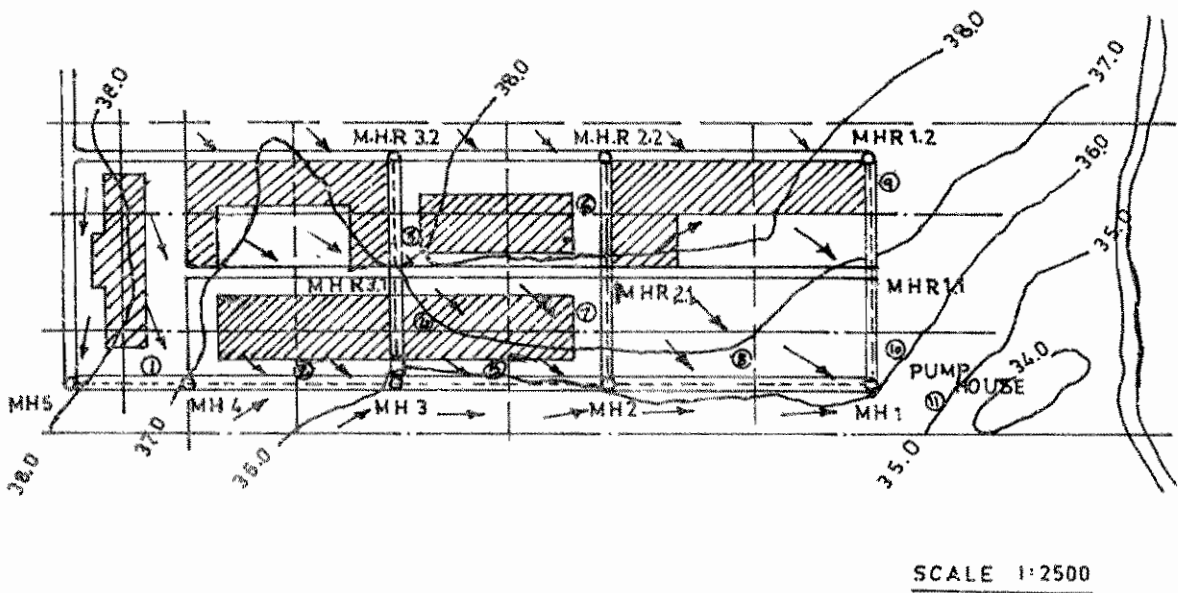

INTENSITY "i" mm/hr	30	35	40	45	50	60
DURATION "t" (minutes)	44	36	28.5	22.5	13.5	9.75

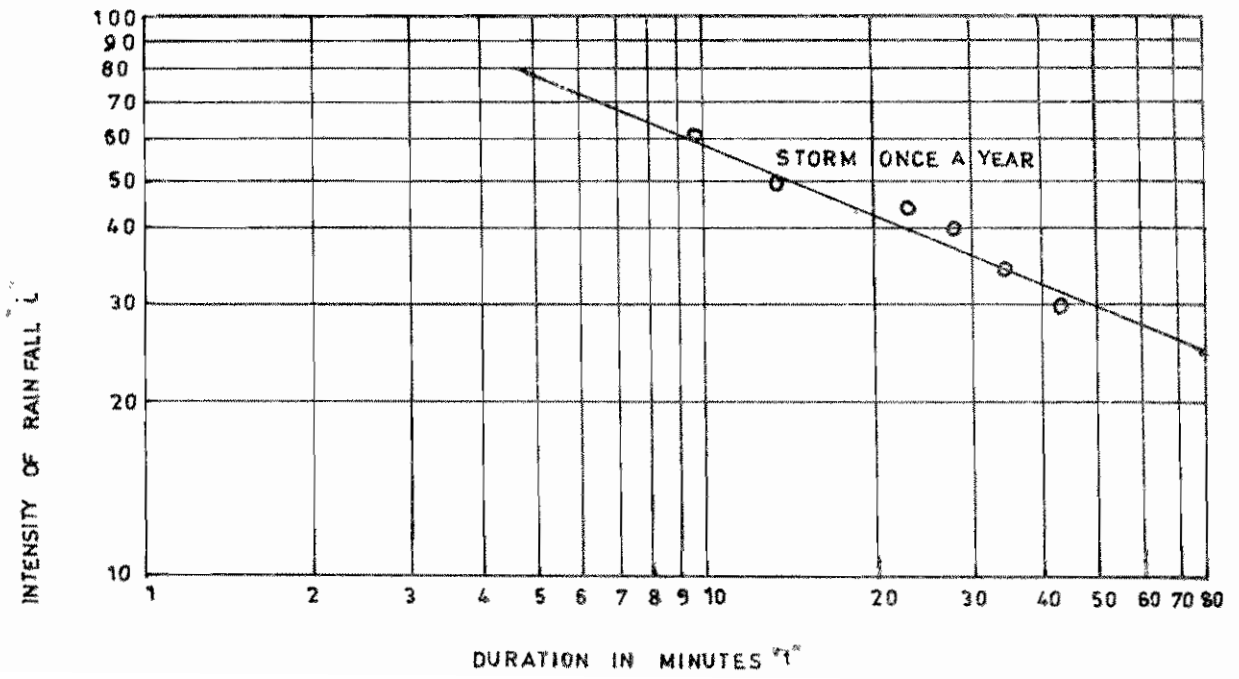

APPENDIX 3.1

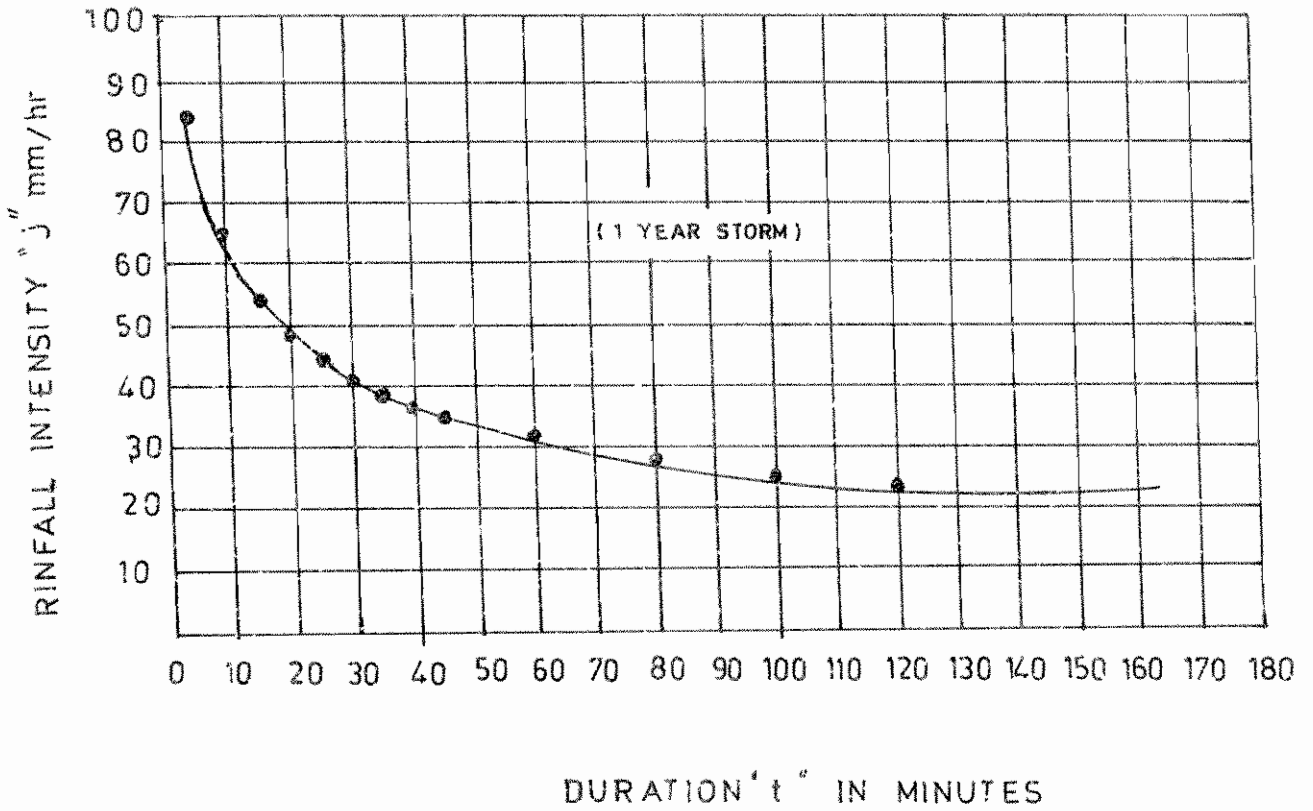

APPENDIX 3.1

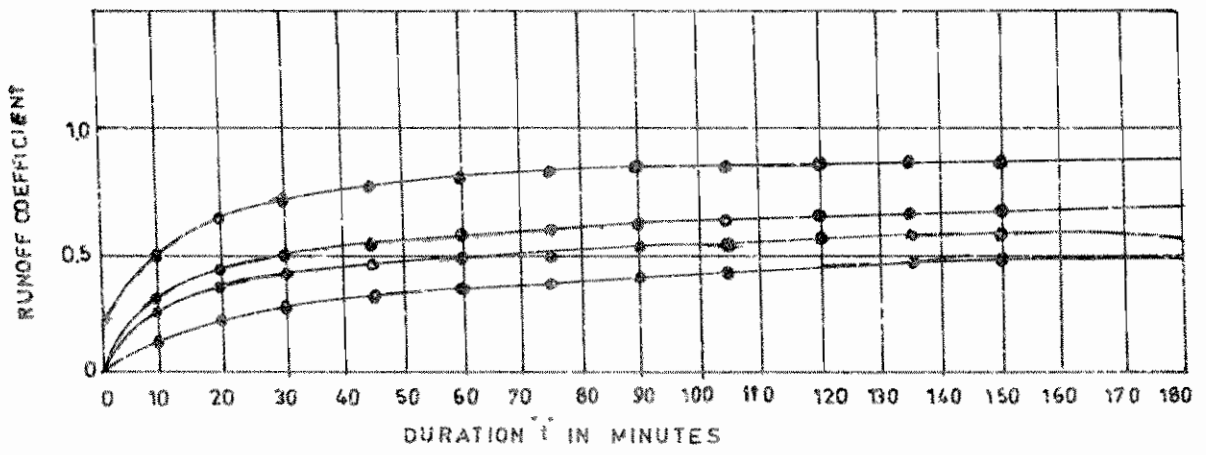

AFTER HORNER AREA-RECTANGLE

APPENDIX 3.1

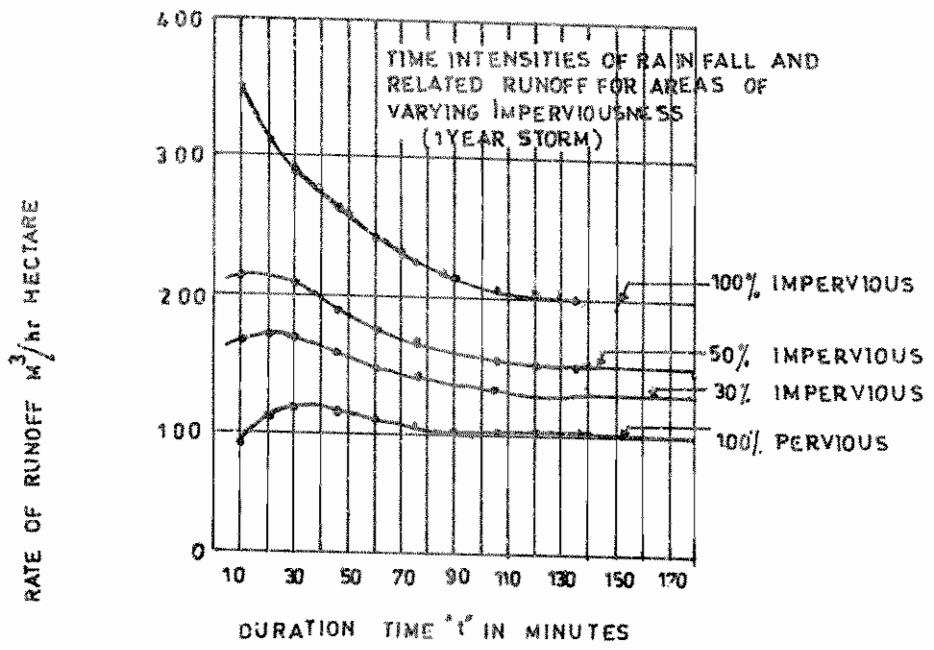

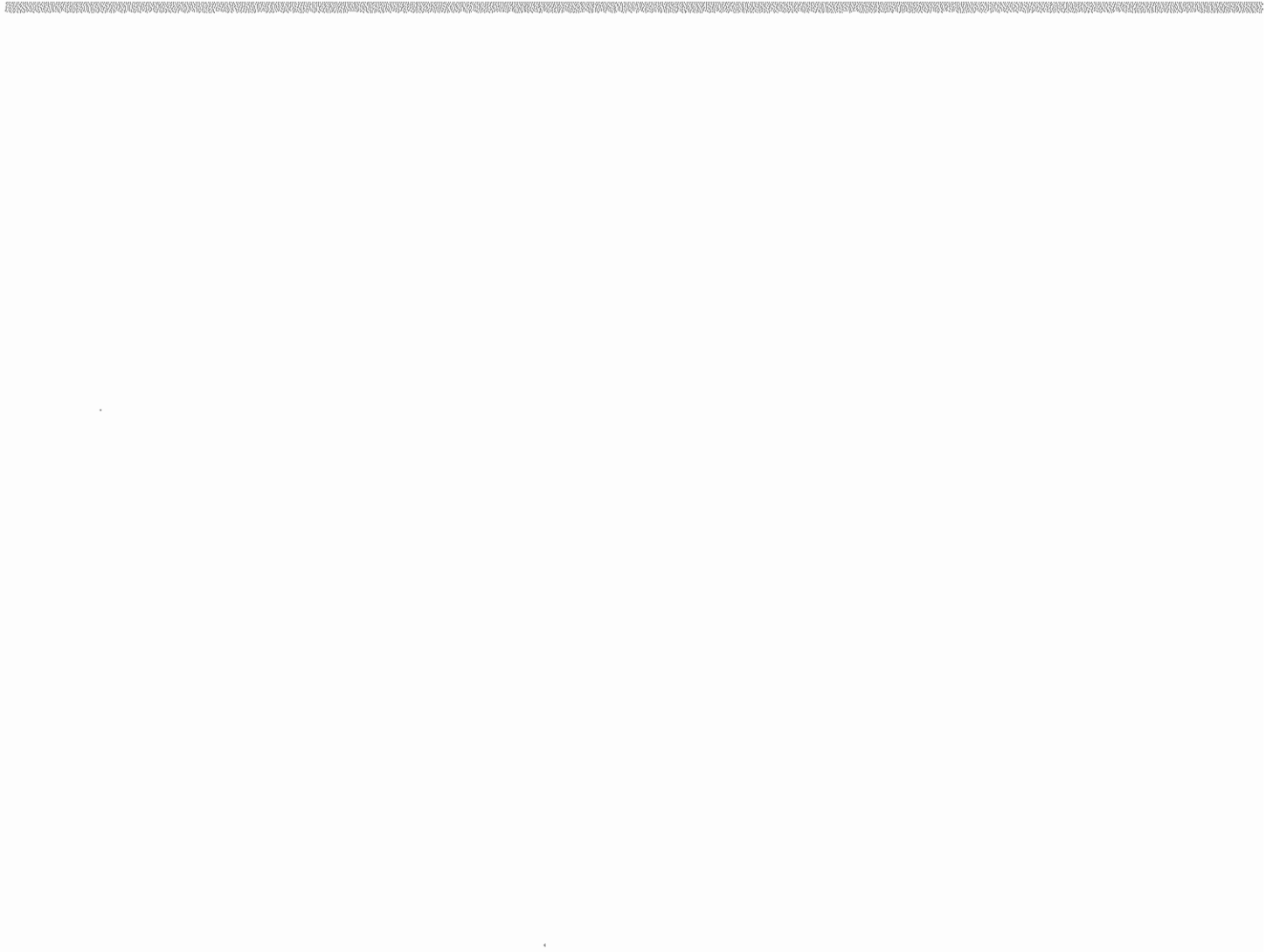

457-A

APPENDIX 3.4

CALCULATION OF BACKWATER CURVE

APPENDIX 3.4

CALCULATION OF BACKWATER CURVE

Problem:

A 3m Diameter Circular sewer laid on a gradient of 0.5/1000 discharges 3 cumecs into a pump well. The Waste water level in the pump well rises to full depth of 3 meters above invert of incoming sewer. Assume a Manning's n value of 0.012 and trace the profile of the back water curve till the flow becomes normal at a depth of 1.2 meters.

Solution:

A 3m diameter sewer on a grade of 5×10^{-4} has a capacity of 10.856 cumecs

$$V = \frac{1}{0.012} \times (3/4)^{2/3} (5 \times 10^{-4})^{1/2}$$

$$\frac{1}{0.012} \times 0.8247$$

$$V = 1.5367 \text{ m/sec.}$$

$$Q_{\text{full}} = 10.856 \text{ cumecs.}$$

$$q/Q = 3/10.856 = 0.276$$

For q/Q of 0.276 d/D is approximately 0.40 for variable n/N .

Hence initial depth of flow is $0.4 \times 3 = 1.2\text{m}$ and the terminal depth = 3m

The length of reach in which the depth changes by a chosen amount is given by Eq.3.16

$$i.e \Delta l = \frac{\Delta(d+h)}{S_b - S_a}$$

The calculations are made in a Tabular form and presented in the Table.

The length of run in which transition from 1.2m to 3m takes place is about 5355m.

APPENDIX 3.4
CALCULATION OF BACK WATER CURVE.

dm	d/D	a/A	r/R	n/N	a	r	v	hv x 10**2	d+hv	n x 10**2	nv x 10**2	AVERAGE					Delta l	Cumulative length	
												R	R**(2/3)	nv x 10**2	S x 10**5	(Se-Sa) x 10**5			(d+hv)
1	2	3	4	5	6	7	8	9	10	11	12	13	14	15	16	17	18	19	20
3.00	1.00	1.000	1.000	1.00	7.07	0.75	0.42	0.90	3.09	1.20	0.504								0
2.40	0.80	0.858	1.217	0.89	6.06	0.91	0.50	1.27	2.41	1.35	0.675	0.83	0.88	0.59	4.50	45.50	0.68	1495	1495
1.80	0.60	0.626	1.110	0.82	4.42	0.83	0.68	2.36	1.82	1.46	0.990	0.87	0.91	0.83	6.32	41.68	0.59	1416	2911
1.20	0.40	0.373	0.857	0.79	2.64	0.64	1.14	6.62	1.27	1.52	1.730	0.74	0.82	1.36	27.50	22.50	0.55	2444	5355

Column 1 = Assumed depth between initial depths of 1.2 mt. and terminal depth of 3.0 mt.

Column 2 = (Column 1) / 3

Column 3, 4 and 5 = Read from figure

Column 6 = (Column 3) x area of sewer

Column 7 = (Column 1) x hydraulic radius of sewer

Column 8 = rate of flow / (column 6)

Column 9 = $(v^2) / 2g$ for column 8

Column 10 = (column 9) + (column 1)

Column 11 = 0.012 (Mannings N) / (column 5)

Column 12 = (Column 11) x (column 8)

Column 13 = Arithmetic mean of successive pairs of values in column 12

Column 14 = (column 13) ** 2/3

Column 15 = Arithmetic mean of successive pairs of values in column 10

Column 16 = $(\text{column 15} / \text{column 14})^2$ i.e. $S = (nv / (r^{2/3}))^2$

Column 17 = (column 16) - i

Column 18 = Difference between successive pairs of values in column 10

Column 19 = (column 18) / (column 17 x 10^{-5}) i.e. $\Delta l = \Delta(d + hv) / (S_e - S_a)$

Column 20 = Cumulative values of column 19

APPENDIX 3.5

DESIGN OF SANITARY SEWER SYSTEM

Problem:

Design a system of sanitary sewers for the given area shown in the figure 5 with the following details:

- | | | |
|---|---|--------------------------|
| 1. Population Density | - | 300 persons/hect. |
| 2. Water Supply | - | 250 lpd/head (ultimate). |
| 3. Maximum rate of infiltration | - | 20,000 lpd/hect. |
| 4. Minimum depth of cover to be provided over the crown of the sewer. | - | 1 m. |
| 5. Minimum velocity in sewer at peak flow. | - | 0.6 mps |
| 6. Maximum velocity in sewer | - | 2.0 mps |
| 7. Minimum size of the sewer | - | 150 mm |
| 8. Waste water reaching sewers | - | 90% of W/S |
| 9. Peak flow | - | 3.5 x Ave flow |

Solution:

1. Draw a line to represent the proposed sewer in each street or valley to be served. Near the line indicate by an arrow the direction in which sewage is to flow.
2. Locate the manhole, giving each an identification number.
3. Sketch the limits of the service areas for each lateral.
4. Measure the areas (ha) of the several service areas.
5. Prepare a table as shown in Table 2 with the columns for the different steps in computation and a line for each section of sewer between manholes.

Column 1-6 for the line manhole, location of the manhole, manhole numbers, ground level at starting manhole and length of line between the manholes.

Column 7-8 the corresponding area for the next street of sewer and in col.8 the sum of the areas are entered.

Column 9 the population served by each corresponding line is entered.

Column 10 shows the sewage flow (mld) through each line. The sewage flow is assumed as 90% of the per capita water supply.

Column 11 shows the ground water infiltration for each area = $20,000 \times 10^{-6} \times \text{Col.8}$.

Column 12 gives the peak flow i.e. $\text{Col.10} \times 3 + \text{Col.11}$.

Column 13 gives the peak flow in lps.

Column 14-15 indicate the diameter and slope of the pipes determined from the Manning's chart.

Column 16-17 indicate the discharge through pipe flowing full and the actual discharge through the pipes i.e. as Col.13.

Column 18 also determined from the Manning's Chart when pipe following full.

Column 19 calculated from the hydraulic elements curve for the circular pipes.

Column 20 gives $\text{Col.6} \times \text{Col.15}$.

Column 21-22 invert levels of the lines are calculated.

TABLE 2
DESIGN OF A SEWER SYSTEM

Line	Location	Manhole		Ground level at starting manhole	Length m	Area Served(ha)		Population	Sewage flow mld	Ground water infiltration mld	Peak flow		Diameter mm	Slope	Discharge lps		Velocity mps		Total fall m	Invert Elevation m	
		From	To			Increment	Total				mld	lps			Q Full	Q Actual	V Full	V Actual		Upper end	Lower end
1	2	3	4	5	6	7	8	9	10	11	12	13	14	15	16	17	18	19	20	21	22
1	Street	R 8.5	R 8.4	38.275	120	0.80	0.80	240	0.054	0.016	0.205	2.37	150	008	14	2.37	0.75	0.57*	0.96	37.125	36.185
2	Street	R 8.4	R 8.3	37.960	116	1.20	2.00	600	0.135	0.040	0.512	5.92	150	008	14	5.92	0.75	0.72	0.93	36.135**	35.205
3	Street	R 8.3	R 8.2	36.873	114	1.40	3.40	1020	0.230	0.068	0.873	10.10	150	008	14	10.10	0.75	0.82	0.91	35.175	34.265
4	Street	R 8.2	R 8.1	36.895	116	0.90	4.30	1290	0.290	0.066	1.10	12.73	150	008	14	12.73	0.75	0.86	0.93	34.235	33.305
5	Street	R 8.1	8	36.420	75	0.70	5.0	1500	0.34	0.10	1.29	14.92	200	005	24	14.92	0.70	0.74	0.38	34.275	33.885
6	Street	8	7	36.117	41	14.5	19.5	5850	1.32	0.39	5.01	57.96	300	005	70	57.96	1.0	1.13	0.21	33.845	33.635
7	Street	7	6	35.830	26	4.8	24.3	7300	1.64	0.48	6.22	71.96	350	005	100	71.96	1.2	1.32	0.13	33.605	33.475
8	Main.St.	6	5	35.105	88	2.2	26.5	7950	1.80	0.53	6.83	79.02	350	005	100	79.02	1.2	1.32	0.44	33.445	33.005
9	-do-	5	4	34.412	86	7.8	34.3	10300	2.31	0.68	8.76	101.35	400	0033	125	101.35	1.0	1.12	0.29	32.975	32.685
10	-do-	4	3	34.181	36	5.0	39.3	11800	2.65	0.70	10.05	116.28	400	0033	125	116.28	1.0	1.14	0.12	32.655	32.535
11	-do-	3	2	34.105	77	1.2	40.5	12150	2.73	0.80	10.35	119.75	400	0033	125	119.75	1.0	1.14	0.26	32.505	32.245
12	-do-	2	1	34.905	117	5.0	45.5	13650	3.07	3.91	11.65	134.79	450	0033	160	134.79	1.0	1.12	0.39	32.208	31.811
13	-do-	1	0	33.250	41	1.7	47.2	14200	3.2	0.94	12.14	140.46	450	0033	160	140.46	1.0	1.12	0.14	31.788	31.641

* Since VEL is less than 0.6 mps, flushing once a day is necessary

** A minimum level difference of 30mm has been provided between the incoming and outgoing sewers to provide necessary slope in the manhole

APPENDIX 3.6**DESIGN OF GRAVITY SANITARY SEWER NETWORK USING COMPUTER PROGRAMME IN BASIC**

The sewer network consists of links (pipes) and nodes (manholes). The pipes are connected by the manholes. One or more links come and join at a node and the sewage is discharged through a downstream link which goes into another manhole. Thus the sewer network consists of links and nodes as if they are connected to a branch of a tree.

The design of sewer network involves selection of appropriate size and slope of a link so as to connect the succeeding node to transport the sewage while meeting the requisite hydraulic parameters. Identification of suitable size of pipe and the corresponding slope form an important part in the sewer network design. An estimate can be made to select each available commercial diameter for a link so that it will meet the constraint of design velocity, quantity of flow, depth of flow, minimum cover depth etc.

A computer (SEWER) programme developed in BASIC language optimises the design of a sewer network for a given layout, flows and pipe diameters by minimising depth of excavation but at the same time meeting the design constraints of excavation depths, scour velocities, maximum velocities etc.

Before collecting the data it is necessary that the requisite drawing showing the ground profile and geometry of the network has to be prepared. The data needed to design the SEWER network are pipe lengths, diameters, nodal demands, ground levels of the nodes, other design constraints such as peak factor, minimum and maximum allowable velocities, Manning's coefficient, maximum cover depth, outfall nodal demand, ground elevations, number of nodes, links etc.

The programme assumes linear ground profiles between the nodes. If the ground profile has depression or hills, then nodes should be introduced at these points.

The SEWER programme can determine minimum and maximum allowable slopes based on minimum and maximum allowable velocities provided. The minimum slope for each link has to be increased if the pipe is flowing more than full so that the pipe flows just full. The actual slope with which the pipe is laid is between the maximum and minimum slopes provided. The pipe slope is chosen to minimise the excavation depth and maintain minimum cover depth for all the links. Since the total cost of the sewer network is a function of both the sizes of pipes and their depths and the quantity of excavation, the programme is run several times so that an appropriate pipe network is obtained.

DESIGN OF THE SEWER NETWORK

If all the data of the network entered are correct then the programme can be RUN to design the network. The more complicated and larger the network, it will take more time to design. The process include renumbering of the nodes and links, assignment of flows, determination of maximum and minimum slopes, calculation of actual pipe slopes and their elevations, determination of velocities and depths of flows in the links, checking of the minimum cover depth and reassigning the original link and node numbers.

The result includes the peak flows, water depths, pipe slopes, minimum slopes, maximum slopes and ground slopes for each link. Also the u/s and d/s ground elevations, crown elevations, invert elevations and excavation depth for each link is given. In respect of nodes, the total excavation depth and the difference in elevation of the highest invert entering the node and that of leaving the node is given. The total length of links in the network, the average weighted diameter and excavation depth and excavation area are also given.

The programme compares crown elevation of connected pipes and ignores minor head losses. Thus the final design is only an approximation which can be refined by the design engineer. The programme assumes that the network has only one outfall and uses Manning's equation to determine the pipe slopes. It assumes that any pipe flowing at 80% full is flowing completely full.

A typical sewer network diagram, the information and data required as input for the computer, results of the SEWER programmes as run in the computer etc., are given below.

DATA AND INFORMATION REQUIRED AS INPUT TO DESIGN A SEWER NETWORK USING MICROCOMPUTER

The BRANCH programme available for SEWER design is capable of designing 300 links and 301 nodes.

The information required to be fed into the computer for the Sewer Design is divided into 3 major parts:

- i. System information
- ii. Link data
- iii. Node data

The nodes and links can be numbered between 1 to 36000, all +ve integers. They need not to be consecutive.

The system data includes the following:

- i. Project title
- ii. Units to be adopted
- iii. Number of the outfall node
- iv. Peak factor
- v. Minimum and Maximum velocities
- vi. Manning's coefficient
- vii. Maximum cover depth

The link data includes the following:

- i. Link numbers 'from' and 'to' i.e. the link number of starting node and ending node
- ii. Length, diameter of the link
- iii. Minimum cover depth for the link

The node data includes the following:

- i. Node number
- ii. Flow input at the node (flow inputs are entered as +ve and flow outputs are -ve. The only node which will have demand or output is the outfall node). Wherever transitions and other changes are encountered, a junction node can be introduced.
- iii. **Ground Elevation**

A model network diagram, the input data, the results of the SEWER.BAS run to design the network is as follows.

<div data-bbox="564 767 885 826" style="border: 1px solid black; padding: 2px; margin: 0 auto;">SEWER</div> <p style="text-align: center;">Version 2.0</p> <p style="text-align: center;">Sewer Piping Network Simulation Program</p> <p style="text-align: center;">Limits ----- LINKS: 300 NODES: 301</p> <p style="text-align: center;">September 1986 * * NOT FOR DISTRIBUTION * *</p>
--

Press any key to start

SEWER File:	SAMPLE
-------------	--------

T I T L E	:	TEST
NO. OF LINKS	:	12
NO. OF NODES	:	13
PEAK FACTOR	:	2.5
MIN VELOCITY (mps)	:	.61
MAX VELOCITY (mps)	:	2.44
MAX COVER DEPTH (m)	:	4.5

[ESC]

Menu

[TAB] -

Next Window

1 : Total = 12

SEWER File : SAMPLE

LINK NO.	FROM NODE	TO NODE	LENGT H (m)	DIA (mm)	MANNIN GS COEF.	MIN COVER DEPTH (m)
1	1	2	60	150	.013	1.5
2	2	3	100	200	.013	1.5
3	4	3	75	150	.013	1.5
4	3	6	75	300	.013	1.5
5	5	6	125	150	.013	1.5
6	6	7	60	600	.013	1.5
7	8	6	45	350	.013	1.5
8	9	8	70	300	.013	1.5
9	13	9	45	200	.013	1.5
10	10	13	45	200	.013	1.5
11	11	9	110	200	.013	1.5
12	12	11	125	150	.013	1.5

[I] - Insert [+] - Add [S] - Search

[HOME] - First

PgUp/Dn - Review

[ESC] - Menu [D] - Delete [C] - Copy

[END] - Last

Next Window

Tab -

1 : Total = 13

SEWER File : SAMPLE

NODE NO.	FIX	FLOW (lps)	ELEV (m)
1		9.55	60
2		6.308	54
3		6.308	53
4		2.523	53
5		4.416	50
6		3.154	49
7			48
8		5.046	48
9		5.677	50
10		7.885	50
11		6.308	51
12		1.892	51
13			50

[I] - Insert [+] - Add [S] - Search
PgUp/Dn - Review
[ESC] - Menu [D] - Delete [C] - Copy
Next Window

[HOME] - First

[END] - Last

Tab -

SEWER File : SAMPLE

OUTFALL NODE

NODE NO.	CROWN ELEV.
7	45

[ESC]

Menu

[TAB]

Next Window

SEWER RESULT :

T I T L E	:	TEST
NO. OF LINKS	:	12
NO. OF NODES	:	13
PEAK FACTOR	:	2.5
MIN SCOUR VEL. (mps)	:	.61
MAX VELOCITY (mps)	:	2.44
MAX COVER DEPTH (m)	:	4.5
SEWER OUTFALL NODE	:	7
CROWN ELEVATION OF OUTFALL NODE (m)	:	45
TOT SYSTEM LENGTH (m)	:	935
AVE WEIGHTED DIAM (mm)	:	227.8075
AVE EXC. DEPTH (m)	:	2.056898
AVE EXC. AREA (sq.m)	:	.4926577

[ESC] Menu [TAB] - Next Window [PgUp] - Review Back
 [SPACE BAR] - Continue

LINK NO.	FROM NODE	TO NODE	PEAK FLOW (lps)	LENGTH (m)	DIA (mm)	WATER DEPTH (mm)	VEL (mps)	PIPE SLOPE %	MIN SLOPE %	MAX SLOPE %	GROUND SLOPE %
1	1	2	23.88	60	150	81.33	2.44	7.50	2.76	7.50	10.00
2	2	3	39.65	100	200	154.74	1.52	1.64	1.64	5.34	1.00
3	4	3	6.31	75	150	85.05	0.61	0.45	0.45	20.72	0.00
4	3	6	61.72	75	300	116.22	2.44	4.04	0.46	4.04	5.33
5	5	6	11.04	125	150	102.46	0.86	0.80	0.59	13.16	0.80
6	6	7	147.67	60	600	425.03	0.69	0.08	0.08	2.39	1.67
7	8	6	67.02	45	350	270.79	0.84	0.24	0.24	3.90	2.22
8	9	8	54.41	70	300	232.10	0.93	0.36	0.36	4.44	2.86
9	13	9	19.71	45	200	154.73	0.76	0.41	0.41	8.93	0.00
10	10	13	19.71	45	200	60.83	2.44	8.93	0.41	8.93	0.00
11	11	9	20.50	110	200	154.74	0.79	0.44	0.44	8.66	0.91
12	12	11	4.73	125	150	67.78	0.61	0.55	0.55	26.36	0.00

469

[ESC] - Menu

[TAB] - Next Window

[PgUp] - Review Back

[SPACE BAR] - Continue

LINK NO.	GROUND ELEV		CROWN ELEV		INVERT ELEV		EXCAVATION DEPTH	
	UPSTRM	DNSTRM	UPSTRM	DNSTRM	UPSTRM	DNSTRM	UPSTRM	DNSTRM
1	60.00	54.00	57.00	52.50	56.85	52.35	3.15	1.65
2	54.00	53.00	52.50	50.86	52.30	50.66	1.70	2.34
3	53.00	53.00	51.50	51.16	51.35	51.01	1.61	1.99
4	53.00	49.00	50.53	47.50	50.23	47.20	2.77	1.80
5	50.00	49.00	48.50	47.50	48.35	47.35	1.65	1.65
6	49.00	48.00	46.39	46.35	45.79	45.75	3.21	2.25
7	48.00	49.00	46.50	46.39	46.15	46.04	1.85	2.96
8	50.00	48.00	48.14	46.50	47.84	46.20	2.16	1.80
9	50.00	50.00	48.32	48.14	48.12	47.94	1.88	2.06
10	50.00	50.00	48.50	48.32	48.30	48.12	1.70	1.88
11	51.00	50.00	48.82	48.33	48.62	48.13	2.38	1.87
12	51.00	51.00	49.50	48.82	49.35	48.67	1.65	2.33

470

[ESC] - Menu

[TAB] - Next Window

[PgUp] - Review Back

[SPACE BAR] - Continue

NODE NO.	INPUT (lps)	GROUND ELEV (m)	EXCAVATION DEPTH (m)	DISTANCE HIGH INVERT TO LOW INVERT (m)
1	9.55	60.00	3.15	0.08
2	6.31	54.00	1.70	0.05
3	6.31	53.00	2.77	0.78
4	2.52	53.00	1.65	0.00
5	4.42	50.00	1.64	0.00
6	3.15	49.00	3.21	1.56
7	-59.07	48.00	2.25	0.00
8	5.03	48.00	1.85	0.05
9	5.68	50.00	2.16	0.30
10	7.89	50.00	1.70	0.00
11	6.31	51.00	2.38	0.05
12	1.89	51.00	1.65	0.00
13	0.00	50.00	1.88	0.00

[ESC] - Menu
[BAR] - Continue

[TAB] - Next Window

[PgUp] - Review Back

[SPACE]

LINK NO.	VOLUME OF EXCAVATION (cum)	EXCAVATION COST
1	21.59	0.00
2	40.39	0.00
3	20.47	0.00
4	51.45	0.00
5	30.94	0.00
6	98.30	0.00
7	37.85	0.00
8	41.63	0.00
9	17.76	0.00
10	16.12	0.00
11	46.77	0.00
12	37.36	0.00
	460.64	0.00

[ESC] - Menu

[TAB] - Next Window

[PgUp] - Review Back

[SPACE BAR] - Continue

APPENDIX 6.1

THREE EDGE BEARING TEST FOR PIPE STRENGTH

The load which the pipe must withstand without failure is termed three-edge bearing strength. For unreinforced concrete pipes, the point of load at which the pipe cracks and fails is the termination of a three-edge bearing test.

For reinforced concrete pipes, these specifications provide two criteria for passing the three-edge bearing test: first, there is an intermediate load based on the appearance of a crack 0.25 mm wide and 0.3 m long. The final requirement for reinforced pipe is the ultimate three-edge bearing strength at the final failure of the pipe where no further load increase can be supported.

In conducting this test, the pipe is placed horizontally on two parallel wooden rails resting on 15cm x 15cm bearing block or other solid support that extends the length of the pipe. An upper bearing block is placed on the top of the pipe. Next, a rigid I-beam or other structural member is placed on the upper bearing block to apply the load to the block.

THREE EDGE BEARING STRENGTHS OF CONCRETE PIPES ARE GIVEN BELOW
TABLE 1

Dia of pipe mm	Load to produce 0.25mm crack (kg/linear meter)				Ultimate load (kg/linear meter)		
	Concrete				Concrete		
	NP ₂ P ₁ P ₂ & P ₃	NP ₃	NP ₄	NP ₁	NP ₂ P ₁ P ₂ & P ₃	NP ₃	NP ₄
1.	2.	3.	4.	5.	6.	7.	8.
80	1040	-	-	-	1560	-	-
100	1040	-	-	1560	1560	-	-
125	-	-	-	-	-	-	-
150	1040	-	-	1560	1560	-	-
200	-	-	-	-	-	-	-
250	1140	-	-	1670	1710	-	-
300	1200	-	-	1790	1800	-	-
350	1260	3040	-	1880	1890	4360	-
400	1360	3460	3460	2020	2040	5190	5190
450	1480	3760	-	2220	2220	5640	-
500	1660	4160	4160	-	2490	6240	6240
600	1900	4720	4720	-	2850	7080	7080
700	2100	5320	5120	-	3150	7980	7980
800	2300	6060	6060	-	3430	9090	9090
900	2500	6760	6760	-	3750	10140	10140
1000	2680	7400	7400	-	4020	11100	11100
1100	2780	8200	8200	-	4170	12300	12300
1200	2880	9000	9000	-	4320	13500	13500
1400	2900	-	10610	-	4470	-	17950
1600	2980	-	12800	-	4470	-	18300
1800	2980	-	13800	-	4470	-	20700

APPENDIX 6.2

ILLUSTRATIVE EXAMPLES FOR STRUCTURAL DESIGN OF BURIED CONDUITS

The general assumptions relating to the characteristics of soil and other factors for the examples are given below:

- i) saturated density of fill(w) = 2000 kg/m^3
- ii) $k.u. = k.u' = 0.130$, ordinary maximum for clay (thoroughly wet)
- iii) r_{sj} for rigid conduit on ordinary bedding = 0.7 for positive projection and -0.3 for negative projection
- iv) projection ratio = 1
- v) concentrated surcharge corresponding to wheel load for Class AA wheel loading = $6.25T$
- vi) Impact factor = 1.5
- vii) Factor of Safety for safe supporting strength = 1.1
- viii) The design also provides for accidental surcharge of drains and accounts for a water load of 75% as per standard practice, based on the assumption that the sewage flow is $3/4$ full.

DETERMINATION OF FILL LOADS OVER PIPES

EXAMPLE I

Problem: Determine the fill load on a 1200mm dia. NP₂ Class concrete pipe installed in a trench of width of 2.3m and depth of 4.00m.

Solution: Pipe thickness 't' = 65mm for D of 1200mm

$$B_c = D + 2t = 1200 + 130 = 1330\text{mm} = 1.33\text{m}$$

$$B_d = 2.3\text{m}$$

$$H = 4.00 - 1.33 = 2.67\text{ m}$$

$$\therefore H/B_d = (2.67 / 2.3) = 1.16$$

B_d is $< 2B_c$. Hence trench formula is applicable.

$C_d = 0.9965$ or 1.00 (from table 6.2) for ordinary maximum for clay.

\therefore From equation (6.6)

$$W_c = C_d \cdot w \cdot B_d^2 = 1.00 \times 2000 \times 2.3^2 = 10,580\text{ kg/m.}$$

EXAMPLE II

Problem: Determine the fill load on a 900mm dia NP₂ Class concrete pipe installed in a trench of width 2.1 m and depth 6.0 m.

Solution: Pipe thickness 't' = 50mm for D of 900mm

$$B_c = D + 2t = 900 + 100 = 1000\text{mm} = 1\text{m.}$$

$$w = 2000\text{kg/m}^2$$

$$H = 6.0 - 1.0 = 5.0\text{m}$$

$$B_d = 2.1\text{m}$$

$$(H / B_d) = (5.0 / 2.1) = 2.38$$

$2B_c < B_d < 3B_c$ Hence either the trench or embankment formula can be used.

From Table 6.3

$$c_d = 1.77188 \text{ or say } 1.8$$

From Equation (6.6)

$$W_c = C_d \cdot w \cdot B_d^2 = 1.8 \times 2000 \times 2.1^2 = 15,876\text{ kg/m or say } 16000\text{ kg/m.}$$

EXAMPLE III

Problem: Determine the fill load on a 1200mm dia NP₂ Class concrete pipe installed as a positive projecting conduit under a fill of 7 m height above the top of pipe. The pipe wall thickness is 65mm and the fill weight 2000 kg/m³.

Solution: Assume $r_{sd} = 0.7$ and $p = 1.0$

$$H = 7 \text{ m}$$

$$B_c = 1200 + 130 = 1330\text{mm} = 1.33\text{m}$$

$$H/B_c = 7/1.33 = 5.26$$

$$r_{sd} \times p = 0.7 \times 1 = 0.7$$

$$C_c = 9 \text{ (from figure 6.3)}$$

Using equation (6.2)

$$W_c = C_c w B_c^2 = 9 \times 2000 \times 1.33^2 = 31,850 \text{ kg/m.}$$

EXAMPLE IV

Problem: Determine the fill load on a 1200mm dia NP₂ Class pipe installed as a negative projection conduit in a trench the depth of which is such that the top of the pipe is 2 m below the surface of natural ground in which the trench is dug. The height of the fill over the top of the pipe is 10 m.

Solution: Assume the width of the trench as 2 m and fill weight, $w = 2000 \text{ kg/m}^3$

Assume $r_{sd} = -0.3$ and $p' = 1.0$

$$H = 10\text{m}, B_d = 2.00\text{m} \quad H/B_d = 10/2 = 5.00$$

$$\text{For values of } p' = 1.0 \quad r_{sd} = -0.3 \text{ and } H/B_d = 5.00$$

$$C_n = 3.2 \text{ (from figure 6.5)}$$

Using equation (6.3)

$$W_c = C_n w B_d^2 = 3.2 \times 2000 \times 2.0^2 = 25,600 \text{ kg/m}$$

EXAMPLE V

Problem: Determine the load on 1500mm dia conduit in tunnel condition 15 m deep in a soil of silty sand.

Solution: The maximum width of excavation (B_1) may be assumed as 1950mm; and the cohesion coefficient (C) of the soil as 500 Kg/m²

$$K_u = 0.15 \text{ and } w = 1800 \text{ kg/m}^3$$

$$H = 15 \text{ m}; B_1 = 1.95 \text{ m}$$

$$H/B_1 = 15/1.95 = 7.7$$

$$C_t = 3.00 \text{ (from figure 6.11)}$$

Using equation (6.8)

$$\begin{aligned} W_t &= C_t B_c (w_c B_c - 2C) = 3.00 \times 1.95 (1800 \times 1.95 - 2 \times 500) \\ &= 3.00 \times 1.95 \times 2510 = 14,680 \text{ Kg/m.} \end{aligned}$$

EXAMPLE VI

Problem: Determine the load on a 600mm dia NP₂ Class pipe (t = 40mm) under 1 m cover caused by 6.25 Tonnes Wheel load applied directly above the centre of pipe.

Solution: L = 1 m (since standard length of conduit 1 m)

$$H = 1 \text{ m}$$

$$B_c = 600 + 80 = 680 \text{ mm} = 0.68 \text{ m}$$

$$(L / 2H) = (1.0 / 2 \times 1) = 0.50$$

$$(B_c / 2H) = (0.68 / 2 \times 1) = 0.34$$

From table 6.5 for values of (L / 2H) = 0.50

$$\text{and } (B_c / 2H) = 0.34$$

$$C_s = 0.248$$

Using equation (6.10)

$$W_{sc} = (C_s PF / L) = (0.248 \times 6250 \times 1.5 / 1.0) = 2325 \text{ kg/m.}$$

EXAMPLE VII

Problem: Determine the load on a 1200mm dia concrete pipe under 2 m of cover resulting from a broad gauge railway track loading;

Solution: Assumed thickness of pipe = 100 mm

$$\text{Axle load } P = 22.5 \text{ tonnes}$$

$$\text{Impact factor } F = 1.75$$

$$\text{Length of sleeper } 2A = D = 2.7 \text{ m}$$

Assume 4 axles spaced 1.84m on the locomotive (2B)

$$M = 4 \times 2B = 4 \times 1.84 = 7.36 \text{ m}; \quad H = 2 \text{ m}$$

$$\text{Weight of track structure} = w_t = 0.3 \text{ T/m}$$

Using equation (6.13)

$$U = \frac{PF+2WB}{4AB} = \frac{PF}{4AB} + \frac{W_i}{2A}$$

$$= \frac{225 \times 1.75}{2.7 \times 1.84} + \frac{0.3}{2.7} \pi m^2$$

$$= 7.925 + 0.111 = 8.036 \text{ tonnes/m}^2$$

$$B_c = 1200 + 200 = 1400 \text{ mm} = 1.4 \text{ m}$$

$$\frac{D}{2H} = \frac{2.7}{2 \times 2} = 0.675$$

$$\frac{M}{2H} = \frac{4 \times 1.84}{2 \times 2} = 1.84$$

From Table 6.5

Influence Coefficient $C_s = 0.652$

Using equation (6.12)

$$W = 4C_s U B_c = 4 \times 0.652 \times 8.036 \times 1.4 = 29.34 \text{ tonnes/m} = 29340 \text{ kg/m}$$

(Since it has been given that it is a broad gauge track, the formula $W = 32.14 C_s B_c$ could be used directly without calculating the value of U).

Using the formula $W = 32.14 C_s B_c$

$$W = 32.14 \times 0.652 \times 1.4 = 29.337 \text{ t/m. or } 29,37 \text{ kg/m}$$

EXAMPLE VIII

Problem: Design the structural requirement for a 900mm dia. NP₃ class sewer pipe which is to be laid in 6m deep trench of 2.0 m width assuming that the total vertical load will account for concentrated surcharge of 6.25 T applied at the centre of the pipe. The water load should also be considered.

Solution: The type of bedding for the purpose of this example may be assumed as Ab class with load factor of 2.8.

$$B_c = 900 + 2 \times 50 = 1000 \text{ mm} = 1.0 \text{ m}$$

$$H = 6 - 1 = 5 \text{ m}$$

$$B_o = 2.0$$

$$H/B_o = 5/2.0 = 2.50$$

$$C_o = 1.764 \text{ (from table 6.3 for saturated top soil)}$$

Using equation (6.6) $W_c = C_o w B_o^2$

$$W_c = 1.764 \times 2000 \times 2^2 = 14110 \text{ kg/m.}$$

$$L = 1 \text{ m, } H = 5 \text{ m}$$

$$\frac{L}{2H} = \frac{1}{10} = 0.1$$

and

$$\frac{B_o}{2H} = \frac{1}{10} = 0.1$$

From Table 6.5 $C_s = 0.019$

Using equation (6.10)

$$W_{sc} = C_s (PF/L) = (0.019 \times 6250 \times 1.5) / 1 = 178 \text{ Kg/m.}$$

$$\text{Water Load } W_w = \frac{22}{7} \times \frac{9}{10} \times \frac{9}{10} \times \frac{1}{4} \times 1000 \times \frac{75}{100} = 471 \frac{\text{kg}}{\text{m}}$$

$$W_t = W_c + W_{sc} + W_w = 14,110 + 178 + 471 = 14759 \text{ or say } 14,800 \text{ kg/m}$$

Safe supporting strength of 900 mm NP₂ pipe with class A_b bedding = [(3750 x 2.8) / 1.5] = 7000 Kgs/m. which is less than the total load on the pipe i.e. 14800 Kgs/m.

Safe supporting strength of 900 mm NP₃ pipe with class A_b bedding = [(10140 x 2.8) / 1.5] = 18928 Kgs/m. which is more than the total load on the pipe i.e. 14800 Kgs/m.

DESIGN OF ANTI FLOTATION BLOCKS

EXAMPLE IX

Problem: A RCC pipeline of internal dia 2000mm and barrel thickness of 115mm is to be laid below Ground level. Each pipe is 2.5 metre long and weighs 2 Tonnes. The minimum overburden required to prevent the pipe from upliftment is to be determined. Where there is no over-burden the size of RCC antiflotation block required to prevent it from flotation is to be determined.

Solution: Depth of cover to prevent flotation of an empty pipeline.

$$H_{\min} \times B_c (w_s - w_o) + W_c = \frac{\pi}{4} B_c^2 w_o$$

Where

H_{\min} - minimum depth of fill required to prevent flotation of empty pipe

B_c - O.D. of pipe, meters

w_s - Density of (soil) fill material = 1800 kg/m³

w_o - Density of water = 1000 kg/m³

To show that the pipe gets lifted up if there is no over burden

Weight of empty pipe $W_c = 2000$ kg/metre

$B_c = 2.00 + 0.23 = 2.23$ metre (O.D. of pipe)

When there is no over burden weight of water

displaced = $(\pi / 4) B_c^2 w_o$

$$(\pi / 4) \times (2.23)^2 \times 1000 = 3910 \text{ Kg or } 3.91 \text{ Tonnes}$$

Since the weight of Empty pipe (2 tonnes) is less than the upward weight of water (3.91 tonnes) the pipe will float.

Depth of minimum overburden required to prevent flotation with a factor of safety 1.2

$$H_{\min} B_c (w_s - w_o) + W_c = (\pi / 4) \times B_c^2 \times w_o$$

$$H_{\min} \times 2.23 (1.8 - 1.00) + 2 = [(\pi / 4)] \times 2.23^2 \times 1 \times (\text{Factor of safety of } 1.2)$$

$$H_{\min} = 1.5 \text{ metres.}$$

Hence it is desirable to provide a cover of 1.5 metres to prevent flotation of pipeline.

Where it is not possible to provide the above minimum over burden anti flotation blocks can be provided for each pipe to prevent flotation of pipeline.

The Anchoring force required to be created is equal to the 1st term of the equation (6-9).

i.e. $H_{min} B_c (w_s - w_o)$

$H_{min} = 1.5\text{m}$ with a factor of safety of 1.2

$B_c = 2.23\text{m}$

$w_s = 1800 \text{ kg/m}^3$

$w_o = 1000 \text{ kg/m}^3$

$1.5 \times 2.23 \times (1.8 - 1.00) = 2680 \text{ kg/metre length of pipe}$

Anchoring force required for each pipe of 2.5 metre long.

$= 2.68 \times 2.5 = 6.7 \text{ Tonnes per pipe.}$

Volume of concrete to be provided :

Submerged weight of concrete: $(2400 - 1000) = 1400 \text{ Kg/m}^3$ or 1.4 tonnes/m^3

Volume $= (6.7 / 1.4) = 4.78 \text{ m}^3$

Provide antiflotation block of size $2.85 \times 1.5 \times 1.20 \text{ m}$ for each pipe of 2.5m long (Figure 6.16).

APPENDIX 8.1

CHARACTERISTICS OF COMMON GASES CAUSING HAZARDS

(All percentages are percent by volume in air)

Sr No	Name of Gas	Chemical Formula	Common Properties	Specific Gravity of Vapour density (Air = 1)	Physiological Effects	Maximum Safe limit %	Exposure		Explosive Limit		Likely Location of Highest Concentration	Most Common Sources
							8 hours	60 minutes	Lower	Upper		
1	2	3	4	5	6	7	8	9	10	11	12	
1	Carbon Dioxide	CO ₂	Colourless, odourless when breathed in large quantities may cause acid taste, non-inflammable	1.53	Cannot be inhaled at 10% for more than few minutes even if subject is at rest and oxygen content is normal. Acts on respiratory nerves.	4.0 to 6.0	0.5				At bottom when heated may stratify at points above bottom	Products of combustion sewer gas, sludge gas. Also issued from carbonaceous strata
2	Carbon Monoxide	CO	Colourless, odourless, tasteless, inflammable, poisonous, non-irritating	0.97	Combines with Haemoglobin of blood. Headache in few hours at 0.02%, unconsciousness in 30 mins at 0.2% to 0.25%, fatal in few hours at 0.1%	0.04	0.005	12.5	74.1	Near top, especially if percent with illuminating gas	Manufactured fuel gas, fuel gas products, combustion products of motor exhausts, fire of almost any kind	
3	Chlorine	Cl ₂	Yellowish green colour, detectable in very low concentration, non-inflammable	2.49	Irritates respiratory tracts, kills most animals in very short time at 0.1%	0.0004	0.0001			At bottom	Chlorine cylinders and feed line leaks	
4	Gasoline	C ₇ H ₁₄ to C ₈ H ₁₈	Colourless, odour noticeable at 0.03%, inflammable	3.0 to 4.0	Anaesthetic effects when inhaled, rapidly fatal at 2.4%, dangerous for short exposure at 1.12 to 2.2%	0.4 to 0.7	0.1	1.3	6.0	At bottom	Service stations, garages, storage	
5	Hydrogen	H ₂	Colourless, odourless, tasteless, inflammable	0.07	Acts mechanically to deprive tissues of oxygen, does not support life			4.0	74.0	At top	Manufacture fuel gas, sludge	
6	Hydrogen Sulphide	H ₂ S	Rotten egg odour in small concentrations, odour not evident at high concentrations, colourless, inflammable	1.19	Exposure for 2 to 15 minutes at 0.01% impairs sense of smell, exposure to 0.07 to 0.1% rapidly causes acute poisoning. Paralyzes respiratory centre, death in few minutes at 0.2%	0.02	0.001	4.30	46.0	Near bottom but may be above bottom if air is heated and highly humid	Coal gas, petroleum, sewer gas, fumes from blasting, sludge gas	
7	Methane	CH ₄	Colourless, odourless, tasteless, highly inflammable, non-poisonous	0.55	Acts mechanically to deprive tissues of oxygen, does not support life	Probably no limit provided oxygen percentage is sufficient	1.0	5.9	15.0	Normally at top extending to a certain depth	Natural gas, sludge gas, manufactured fuel gas, sewer gas in swamps or marshes	
8	Nitrogen	N ₂	Colourless, tasteless, non-inflammable, principal constituent of air (about 79%)	0.97	Physiologically inert					Near top but may be found at bottom	Sewer gas, sludge gas, also issues from some rock strata	

APPENDIX 8.1

CHARACTERISTICS OF COMMON GASES CAUSING HAZARDS

(All percentages are percent by volume in air)

Sl No	Name of Gas	Chemical Formula	Common Properties	Specific Gravity of Vapour density (Air = 1)	Physiological Effects	Maximum Safe limit %		Explosive Limit		Likely Location of Highest Concentration	Most Common Sources
						60 minutes	8 hours	Lower	Upper		
1	2	3	4	5	6	7	8	9	10	11	12
9	Oxygen (in air)	O ₂	Colourless tasteless odourless supports combustion non poisonous	1.11	Normal air contains 21% of oxygen man can tolerate down to 12% minimum safe limit 8 hours exposure 14 to 16% Below 10% dangerous to life Below 5 to 7% probably fatal					Variable at different levels	Oxygen depletion from poor ventilation and absorption or chemical combustion of available oxygen
10	Sludge Gas	About 60% methane and 40% carbon dioxide with small amounts H ₂ , N ₂ , H ₂ S, O ₂	May be partially odourless colourless inflammable	0.94	Will not support life	Would vary widely with composition		5.3	19.3	Near top of structure	For digestion of sludge in tanks

APPENDIX 8.2

Equipment and simple tests for detection of gases and oxygen deficiency.

Combustible gas indicators are used for testing the atmosphere for hazardous concentration of inflammable gases and vapours and for making quantitative estimates of the percentage of combustible gas present. The indicator consists of a battery operated unit, which oxidises or burns a sample of atmosphere to be tested over a heated catalytic filament which is a part of a balanced electrical circuit. Combustibles in the samples are burned on the hot wire, thus raising its temperature and increasing its resistance in proportion to the concentration of the combustibles in the sample. The imbalance in the electrical circuit causes the deflection of the pointer of the meter which indicates on a scale, the concentration of combustible gases or vapours in the sample. This scale is calibrated in percentages of the lower explosive limit. The indicator is generally calibrated for a single specific inflammable gas, but may also be calibrated for known mixtures of gases and vapours. The types of combustible gas indicator may be selected to suit the gas or vapour usually encountered.

Carbon monoxide indicator may be used to detect the percentage of the gas present. There are both hand operated and battery operated units which determine electrically the percentage of carbon monoxide present. They are very sensitive to low concentrations of gas and reliably indicate low but dangerous concentrations of carbon monoxide.

The sample of the atmosphere drawn into the indicator is oxidised to carbondioxide by catalytic action. The heat liberated by oxidation is proportional to the amount of carbon monoxide present and is measured by a differential thermocouple in series with the indicating meter which is calibrated to read directly the percentage of carbon monoxide in the atmosphere.

Colorimetric detectors are used to detect specific gases like carbon monoxide, hydrogen sulphide etc. In a specific gas detector, when a sample of the atmosphere is drawn into the instrument, that specific gas reacts chemically with the special substance in the detector producing a change in colour. The colour with its intensity produced is compared with a chart to estimate the percentage of the specific gas present.

In the carbon monoxide detector the chemical used is iodine pentoxide or palladium chloride. In hydrogen sulphite detector the chemical used is lead acetate.

Oxygen deficiency indicator is an adaptation of the flame safety lamp used by miners, for testing the atmosphere suspected of being deficient in oxygen. Normally the indicator is used from an external source to test the suspected atmosphere. The sample of air is drawn in, using an aspirator bulb and the flame inside the lamp is observed. When the atmosphere is normal the flame of the lamp will have normal appearance. With decreased oxygen content in the atmosphere and the absence of another combustible gas, the flame will be dimmer. When the oxygen content in the atmosphere is as low as 16% or lower, the flame will be extinguished.

At altitudes more than 1500m above sea level, the flame may continue to burn even if the percentage of oxygen in the atmosphere is less than 16%. Hence this possibility must be considered at high altitudes

Simple tests: In the absence of the indicators and detectors mentioned above, the following simple tests must be conducted after providing sufficient forced or natural ventilation.

In asphyxiating conditions, a safety lamp must be used. The lamp should burn continuously for atleast 5 minutes in the atmosphere under test. It is essential to check if the lamp is undamaged before being used.

For hydrogen sulphide, a filter paper moistened with 5% solution of lead acetate is exposed for five minutes to the atmosphere under test. As hydrogen sulphide is heavier than air, the atmosphere at the bottom of the manhole should be tested. The presence of hydrogen sulphide gas is indicated by the paper turning grey or brown. The greater the percentage of the gas, the darker will be the colour.

Detectors and indicators for various gases and oxygen deficiency normally encountered in sewage works are as follows:

Gas or Vapour	Detector
Hydrogen Sulphide.	Lead acetate impregnated paper, (qualitative) Hydrogen sulphide ampoules, Hydrogen sulphide detector (qualitative)
Methane	Combustible gas indicator, Oxygen deficiency indicator, Methane alarm.
Carbon dioxide.	Oxygen deficiency indicator.
Nitrogen.	Oxygen deficiency indicator.
Oxygen.	Oxygen deficiency indicator.
Carbon monoxide.	Carbon monoxide indicator, Carbon monoxide tube (quantitative)
Hydrogen	Combustible gas indicator Oxygen deficiency indicator.
Gasoline	Combustible gas indicator Oxygen deficiency indicator. (for concentration over 0.3%)
Sludge	Combustible gas indicator Oxygen deficiency indicator Methane alarm.
Chlorine	Aqueous ammonia, Odour.

APPENDIX 11.1

EXAMPLE FOR HYDRAULIC DESIGN OF MECHANICALLY
CLEANED BAR RACK AND SCREEN CHAMBER**Problem Statement**

Design a bar rack and screen chamber for a peak design flow of 150 MLD (3 x average wastewater flow of 50MLD) with the following data.

- | | | | |
|----|--|---|-------------------------|
| 1. | Peak design flow | = | 1.736 m ³ /s |
| 2. | Flow conditions in incoming trunk sewer | | |
| | (a) Diameter of incoming sewer | = | 1.40 m |
| | (b) Depth of flow in sewer at peak flow | = | 1.05 m |
| | (c) Velocity in sewer at peak design flow | = | 1.16 m/s |
| 3. | Drop of screen chamber floor with respect to sewer invert. | = | 0.08 m |
| 4. | Assumed width of rectangular bars | = | 10 mm |
| 5. | Clear spacing between bars | = | 25 mm |

Sketch a hydraulic profile through bar rack under clean conditions as well as for 50% clogged conditions

Solution

I. Design of Bar Rack

- | | | | |
|------|---|---|---------|
| i) | Assume depth of flow in screen chamber | = | 1.05 m |
| ii) | Assume velocity of flow through rack openings | = | 0.9 m/s |
| iii) | Clear area of openings through the rack | | |

$$= \frac{Q}{V} = \frac{1.736}{0.9} = 1.929 \text{ m}^2$$

Clear width of openings through rack = $1.929 / 1.05 = 1.84 \text{ m}$

Provide 73 clear spacings of 25mm each

Number of bars = 72 of 10mm each

Total width of the screen chamber

$$= \frac{73 \times 25}{1000} \times \frac{1}{1000} + 72 \times \frac{10}{1000} = 2.545 \text{ m}$$

II. Actual Depth of Flow in Screen Chamber at Peak Flow

The longitudinal section of the screen chamber is divided into four sections. The section 1 is at sewer, section 2 at screen chamber u/s of bar rack, section 3 at d/s of bar rack and section 4 u/s of the outlet of screen chamber. It is assumed that the outlet channel/sewer from screen chamber discharges freely into the sump well. The definition sketch is given in Fig.11.1

Applying Bernoulli's theorem between sections 1 and 2

$$Z_1 + d_1 + (V_1^2 / 2g) = Z_2 + d_2 + (V_2^2 / 2g) + h_L$$

where	Z_1 & Z_2	-	datum heads
	d_1 & d_2	-	depths of flow at sections 1 and 2
	V_1 & V_2	-	velocities of flow at sections 1 and 2
	h_L	-	head loss due to sudden expansion from sewer to screen chamber

$$= K_e \left[\frac{V_1^2}{2g} - \frac{V_2^2}{2g} \right]$$

Taking floor of the screen chamber as datum ($Z_2 = 0$) and assuming $K_e = 0.3$ for coefficient of expansion.

$$0.08 - 1.05 + \left(\frac{1.16}{2g} \right)^2 = 0 + d_2 + \frac{\left(\frac{1.736}{2.545 d_2} \right)^2}{2 \times 9.81} + \frac{0.3}{2 \times 9.81} \left[1.16^2 - \left(\frac{1.736}{2.545 d_2} \right)^2 \right]$$

$$d_2^3 - 1.178 d_2^2 + 0.0166 = 0$$

Solving by trial and error

$$d_2 = 1.17 \text{ m}$$

$$V_2 = \left[(1.736) / (2.545 \times 1.17) \right] = 0.583 \text{ m/s}$$

III. Velocity through clear opening of bar rack

$$V = \frac{\text{Flow}}{\text{Net Area of opening through rack}}$$

$$= \frac{1.736}{73 \times 0.025 \times 1.17} = 0.813 \text{ m/s}$$

The velocity through the bar rack was assumed to be 0.9 m/s but it is actually 0.81 m/s. If desired, the steps I, II and III can be revised to yield different values of number of bars, depth of flow and velocity of flow etc. However as V is within range (0.6-1.2 m/s), these steps are not being revised, being acceptable.

IV. Head Loss Through Bar Rack

$$h = 0.0728 [V^2 - V_2^2] = 0.0728 [0.813^2 - 0.573^2]$$

$$= 0.024 \text{ m}$$

Using Kirschmer's Formula

$$h = \beta (Wb)^{4/3} h_p \sin \theta$$

$$= 2.42 \left(\frac{72 \times 10}{73 \times 25} \right)^{4/3} \left(\frac{0.813^2}{2 \times 9.81} \right) \sin 75^\circ$$

$$= 0.022 \text{ m}$$

V. Determine depth and velocity of flow d/s of Bar Rack

Applying energy equation between sections 2 and 3

$$Z_2 + d_2 + \frac{V_2^2}{2g} = Z_3 + d_3 + \frac{V_3^2}{2g} + h$$

When bar rack is clean

$$0 + 1.17 + \frac{(0.573)^2}{2 \times 9.81} = 0 + d_3 + \frac{\left(\frac{1.736}{2.545 d_3}\right)^2}{2 \times 9.81} + 0.024$$

$$d_3^3 - 1.163 d_3^2 + 0.0237 = 0$$

$$d_3 = 1.15 \text{ m}$$

$$V_3 = \frac{1.736}{2.545 \times 1.15} = 0.593 \text{ m/s}$$

VI. Head loss through Bar Rack at 50% Clogging

Assuming d_2^1 and v_2^1 as depth and velocity of flow at section 2 when bar rack is 50% clogged

$$d_2^1 + \frac{(V_2^1)^2}{2g} = d_3 + \frac{V_3^2}{2g} + h_{50\%}$$

$$h_{50\%} = 0.728 [(Velocity \text{ through clogged rack})^2 - V_2^2]$$

$$= 0.0728 \left[\left(\frac{1.736}{73 \times 0.025 \times 0.5 \times d_2^1} \right)^2 - \left(\frac{1.736}{2.545 d_2^1} \right)^2 \right]$$

$$= \frac{0.23}{(d_2^1)^2}$$

$$d_2^1 + \frac{\left(\frac{1.736}{2.545 d_2^1}\right)^2}{2g} = 1.15 + \frac{(0.593)^2}{2 \times 9.81} + \frac{0.23}{d_2^1}$$

$$(d_2^1)^2 - 1.168 (d_2^1)^2 - 0.206 = 0$$

$$d_2' = 1.30m$$

$$V_2' = \frac{1.736}{1.30 \times 2.545} = 0.525 m/s$$

Head loss under 50% clogging of bar rack, $h_{50\%}$

$$= \frac{0.23}{(1.30)^2} = 0.136 m < 0.15 m \text{ hence O.K.}$$

VII. Floor Raising required in channel before free fall into Sump Well.

If the flow d/s of bar rack has to be designed for free fall conditions into the adjoining sump well of pumping station, it is obvious that critical flow conditions will prevail near the outfall.

Depth of critical flow,

$$d_c = \left(\frac{Q^2}{gb^2} \right)^{\frac{1}{3}}$$

$$= \left[\frac{(1.736)^2}{9.81 \times (2.545)^2} \right]^{\frac{1}{3}} = 0.362m$$

$$\text{Critical velocity, } V_c = \frac{1.736}{2.545 \times 0.362} = 1.88 m/s.$$

In order not to disturb the existing hydraulic profile at section 3 and beyond, the floor of the screen chamber has to be raised by an amount Z_c , which can be determined by applying Bernauli's Theorem between sections 3 and 4.

$$Z_3 + d_3 = (V_3^2 / 2g) = Z_4 + Z_c + d_4 + (V_4^2 / 2g) + \text{head loss}$$

Since $Z_3 = Z_4$, $d_3 = d_4 = d_c = 0.362 m$, $V_4 = V_c = 1.88 m/s$ and neglecting head loss.

$$0 + 1.15 + \frac{(0.593)^2}{2 \times 9.81} = 0 + Z_c + 0.362 + \frac{(1.88)^2}{2 \times 9.81} + 0$$

APPENDIX 11.2

DESIGN EXAMPLE FOR GRIT CHAMBER WITH PROPORTIONAL
FLOW WEIR AS HYDRAULIC CONTROL DEVICE

PROBLEM STATEMENT

Design grit chamber to treat peak design flow of 150 MLD (3 X Average waste water flow of 50 MLD) of wastewater to remove grit particles upto a size of 0.15mm and of specific gravity of 2.65. The minimum temperature is 15 degree C. The grit chamber is equipped with proportional flow weir as control device.

SOLUTION

- i. Computation of settling velocity

Applying Stoke's Law

$$V_s = \frac{g}{18} (S_s - 1) \frac{d^2}{\nu}$$

Given $S_s = 2.65$, $d = 0.15 \times 10^{-3}$ m

$$\nu = 1.14 \times 10^{-6} \text{ m}^2/\text{s at 15 degree c}$$

$$V_s = \frac{9.81}{18} (2.65 - 1) \frac{(0.15 \times 10^{-3})^2}{1.14 \times 10^{-6}} = 0.018 \text{ m/s}$$

Check for Reynold's Number, R

$$R = \frac{V_s d}{\nu} = \frac{0.018 \times 0.15 \times 10^{-3}}{1.14 \times 10^{-6}} = 2.37 > 0.5$$

Hence Stoke's law does not apply

Applying Transitions Law for $0.5 < R < 10^3$

$$V_s = [0.707(S_s - 1) d^{1.6} \nu^{-0.6}]^{0.714}$$

$$= [0.707(2.65 - 1)(0.15 \times 10^{-3})^{1.6} (1.14 \times 10^{-6})^{-0.6}]^{0.714}$$

$$= 0.0168 \text{ m/s.}$$

ii. Computation of surface overflow rate, SOR

The surface overflow rate for 100% removal efficiency in an ideal grit chamber	=	Settling velocity of the minimum size of particle to be removed
	=	0.0168 m/s
	=	1451.5 m ³ /m ² /d

However, due to turbulence and short circuiting due to several factors as eddy, wind and density currents, the actual value to be adopted has to be reduced taking into account the performance of the basin and the desired efficiency of the particles removal. To determine the actual overflow rate, the following formula may be used.

$$\eta = 1 - \left(1 + n \frac{V_s}{Q/A}\right)^{-1/n}$$

where η = efficiency of removal of desired particles

n = measure of settling basin performance

= 1/8 for very good performance

Assuming $\eta = 75\%$, $n = 1/8$

$$\left(\frac{Q}{A}\right) = \frac{V_s n}{[1 - \eta]^{-n} - 1}$$

$$= \frac{1451.5 \times \frac{1}{8}}{(1 - 0.75)^{-1/8} - 1} = 959 \text{ m}^3/\text{m}^2/\text{d}$$

iii. Determination of the dimensions of grit chamber

Plan Area of grit chamber = [Q / (Q / A)]

$$\frac{150 \times 10^3}{959} = 156.4 \text{ m}^2$$

Provide 4 channels of 2.5 m wide and 16m long.

The critical displacement velocity to initiate resuspension of grit is given by

$$V_c = \left[\frac{8K}{f} (S_s - 1) g d \right]^{0.5}$$

for $k = 0.04$, $f = 0.03$, $S_s = 2.65$, $d = 0.15 \times 10^{-3}$ m

$$V_c = 0.161 \text{ m/s}$$

The horizontal velocity of flow V_h should be kept less than critical displacement velocity, V_c

Assuming a depth of 1.1 m

$$V_h = \frac{1.736}{1.1 \times 4 \times 2.5} = 0.158 \text{ m/s} < 0.161 \text{ m/s O.K.}$$

The hydraulic residence time at peak flow is

$$\text{HRT} = \frac{\text{Volume}}{\text{Peak discharge}} = \frac{4 \times 2.5 \times 16 \times 1.1}{1.736} = 101.38 \text{ seconds}$$

Total depth of grit chamber = Water depth + free board + grit storage space

$$= 1.1 + 0.25 + 0.25 = 1.6 \text{ m}$$

Provide 4 channels of grit chamber, each 16m x 2.5m x 1.6m

iv Design of proportional Flow Weir

There will be four proportional flow weirs, each installed at the control section of each of the four grit chambers.

$$\text{Peak flow for each weir} = (1.736 / 4) = 0.434 \text{ m}^3/\text{s}$$

Flow through a proportional flow weir is given by

$$Q = Cb\sqrt{2ag}[h - (a/3)]$$

For symmetrical sharp-edged weir, $c = 0.61$

Assuming $a = 35 \text{ mm}$ (usually between 25-50 mm)

$h = 1.1 \text{ m}$ at peak flow

$$0.434 = 0.61 \times b (2 \times 0.035 \times 9.81)^{0.5} (1.1 - 0.035/3)$$

$b = 0.79$ say 0.80 m

To determine the coordinates (x,y) of the curve forming the edge of the weir, assume suitable four values of y and compute corresponding values of x using equation.

$$x = \frac{b}{2} \left[1 - \frac{2}{\pi} \tan^{-1} \sqrt{\frac{y}{a} - 1} \right]$$

The coordinates for proportional flow weir are listed below:

Sl. No.	y,m	x,m
1.	$a = 0.035$	0.400
2.	$10a = 0.35$	0.082
3.	$20a = 0.70$	0.057
4.	$30a = 1.05$	0.047
5.	$40a = 1.40$	0.040

**APPENDIX 12.1
DESIGN OF SECONDARY SEDIMENTATION TANK**

Problem: Design secondary sedimentation tank to treat effluent from Activated Sludge Plant with the following design data.

Average wastewater flow = 50 mld

MLSS concentration in influent = 3000 mg/l

Peak flow factor = 2.25

Solution: Adopting a surface loading rate of 20 cum/day/sqm at average flow,

$$\text{Surface area required} = \frac{50 \times 10^6}{20 \times 1000} = 2500 \text{ sqm.}$$

Check for the surface loading at peak flow:

$$\text{Surface loading} = \frac{50 \times 2.25 \times 10^6}{2500 \times 1000} = 45 \text{ cum/day/sqm}$$

(O.K. as it is in prescribed range of 40 - 50)

For a solid loading of 80 Kg/day/sqm at average flow,

$$\text{area required} = \frac{50 \times 10^6 \times 3000}{1000 \times 80 \times 1000} = 1875 \text{ sqm.}$$

Area needed for peak flow at a solids loading of 210 kg/day/sqm

$$= \frac{50 \times 2.25 \times 10^6 \times 3000}{1000 \times 210 \times 1000} = 1607 \text{ sqm.}$$

The higher surface area of 2500 sqm is to be adopted

Adopting a circular tank

$$\text{Diameter} = \sqrt{\frac{2500 \times 4}{\pi}} = 56.42 \text{ m say } 57 \text{ m}$$

$$\text{Weir loading} = \frac{50 \times 1000}{\pi \times 57} = 279.21 \text{ Cu.m/day/m}$$

(Not O.K. as weir loading > permissible value of 150 cum/day.m)

Hence provide outlet arrangement consisting of effluent launder with weirs on both sides of launder.

OUTLET ARRANGEMENT:

The outlet arrangement consists of effluent weir of V-notches, effluent launder, effluent box and a pressure outlet pipe.

i) **Effluent Weir:**

Length of effluent weir plate on each side of launder

$$= \pi \times (57 - 1) = 175.93 \text{ say } 176 \text{ m}$$

Provide 90° V-notches @ 20 cm centre to centre on both sides of the launder.

$$\text{Total No. of notches} = 176 \times 5 = 880$$

Average discharge per notch at average design flow

$$= \frac{50 \times 10^6}{24 \times 60 \times 60 \times 880 \times 1000} = 6.58 \times 10^{-4} \text{ cuml sec.}$$

The discharge through a V-notch is given by

$$Q = \frac{8}{15} C_d \sqrt{2g} \tan \frac{\theta}{2} H^{\frac{5}{2}}$$

$$\text{for peak flow per notch, } Q = 6.58 \times 10^{-4} \times 2.25 = 1.48 \times 10^{-3} \text{ cum/s}$$

$$\text{for } C_d = 0.584, \theta = 90$$

Head over V-notch at peak flow =

$$\left(\frac{15 \times 1.48 \times 10^{-3}}{8 \times 0.584 \times \sqrt{2 \times 9.81}} \right)^{\frac{2}{5}} = 0.065 \text{ m}$$

Provide 8 cm deep 90 degree V-notches at 20 cm centre to centre.

(ii) **Effluent launder:**

Assume the width of effluent launder or channel to be 0.6 m. To compute depth of effluent launder, assume that the effluent launder discharges freely into the effluent box. Consequently the depth at the end of effluent channel may be assumed equal to critical depth of flow. Critical depth at the end of effluent launder, Y_2 is

$$Y_2 = \left(\frac{(q'xL)^2}{(b^2xg)} \right)^{\frac{1}{3}}$$

$$Y_2 = \left[\frac{\left(\frac{50 \times 10^3}{2 \times 24 \times 3600} \right)^2}{(0.6^2 \times 9.81)} \right]^{\frac{1}{3}} = 0.287 \text{ m}$$

Depth of water at upper end of the trough, Y_1

$$Y_1 = \sqrt{Y_2^2 + \frac{2x(q'xLxN)^2}{gxb^2xY_2}}$$

$$Y_1 = \sqrt{0.287^2 + \frac{2 \left(\frac{50 \times 1000}{2 \times 24 \times 3600} \times 2 \right)^2}{9.81 \times 0.6^2 \times 0.287}} = 0.862 \text{ m}$$

Provide a depth of 0.95 m.

APPENDIX 12.1

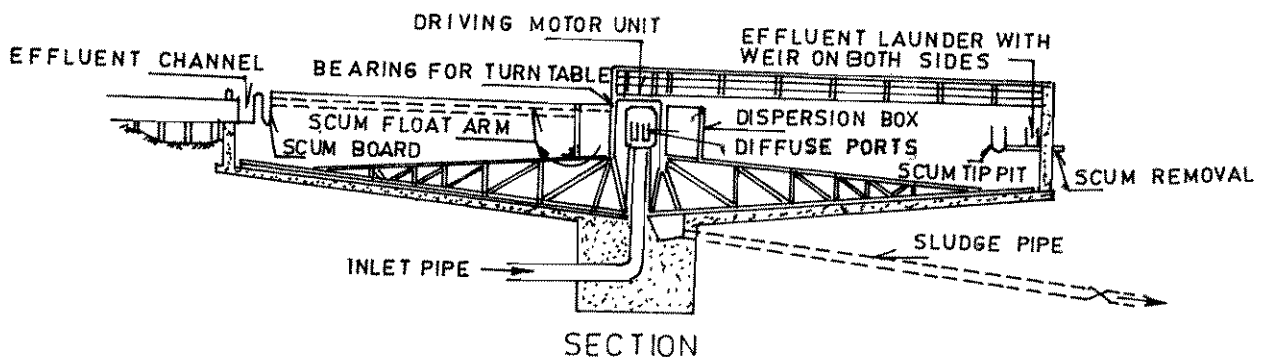
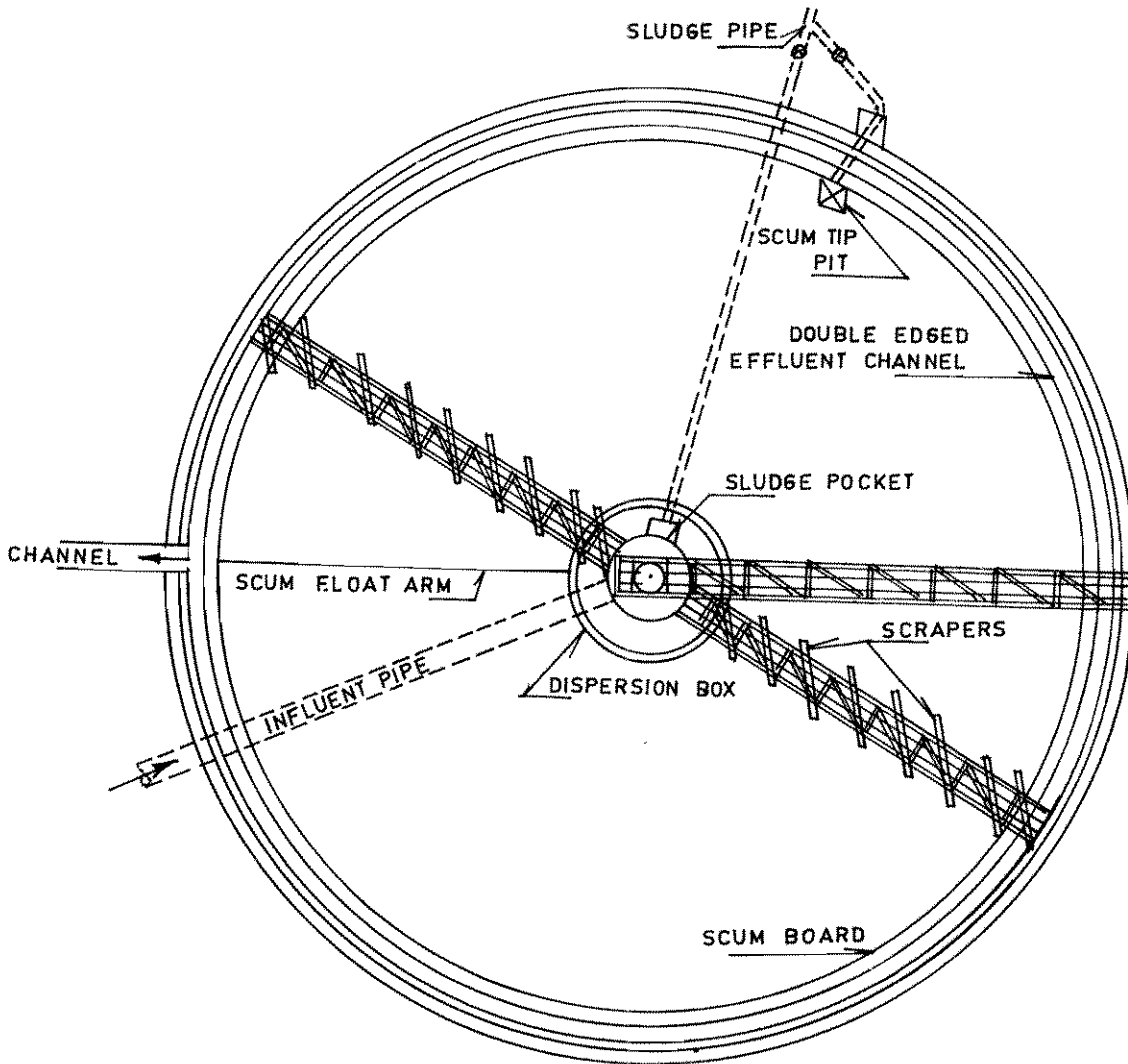

SECTION

TYPICAL DETAILS OF SEDIMENTATION TANK

APPENDIX 13.1

DESIGN OF CONVENTIONAL ACTIVATED SLUDGE PROCESS

Given :

Flow = 50,000 m³/d, Raw wastewater BOD₅ = 250 mg/l; SS = 400 mg/l; Minimum and maximum temperature = 18 and 32° C respectively; Primary Sedimentation efficiency for BOD and SS removal = 35% and 75% respectively; Primary and Secondary excess sludge SS concentration = 40 and 10 kg/m³, Aeration equipment oxygen transfer efficiency under standard conditions = 1.8 kg O₂/kWh.

Aeration tank volume:

- BOD of influent to aeration tank = $250 \times 65 / 100 = 162.5$ mg/l
- For 90% BOD removal read θ_c for 18° C from Fig.(13.3) = 6.5 days
- Adopt for conventional activated sludge MLSS = 2000 mg/l
- Assuming $Y = 0.5$ and $k_d = 0.06/d$ from Eq.(13.7) calculate $V = 8549$ m³
- HRT from Eq.(13.1) = 4.1 h, which is greater than 4 h, hence acceptable. However, if a larger HRT value is desired, repeat calculations assuming lower value of MLSS.
- The dimensions of the tank will be decided on the basis of aeration equipment requirements and conditions detailed in section 13.4.1.

Excess Sludge:

- Calculate $Q_w X_s$ from Eq.(13.3) = 2630461.5 g SS/d or 2630 kg/d.
- For 10 kg/m³ SS concentration in secondary sludge, excess sludge volume = 263 m³/d.

Sludge Recirculation:

- Calculate sludge recirculation ratio from Eq.(13.10) = 0.25, which is between 0.25 and 0.5, hence acceptable. However, provide for 0.33.
- Therefore sludge recirculation pump capacity
= $0.33 \times 50,000 = 16,500$ m³/d.

Oxygen Requirement:

- Calculate oxygen requirement from Eq.(13.8) assuming $f = 0.68$; = 7018420 g/d
- Calculate kg O₂ required/kg BOD removed = 0.96 which is between 0.8 and 1.0, hence acceptable.

Aerator Power Requirement:

- For field conditions; temperature = 32 degree C assuming $C_L = 1$ mg/l, $C_s = 7.2$ mg/l and $\alpha = 0.8$ calculate oxygen transfer capacity of available aeration equipment from Eq.(13.9) = 1.3 kg O₂/kW.h.
- Therefore aeration equipment power requirement
= $7018 / 24$ kg O₂ / h / 1.3 kg O₂ / kW.h = 225 kW.

Sludge Generated:

- Primary sludge solids
= $50,000 \text{ m}^3/\text{d} \times 400 \text{ g/m}^3 \times 0.75 \times 1 \text{ kg} / 1000\text{g}$
= 15000 kg/d
 - Primary sludge volume
= $15000 \text{ kg/d} / 40 \text{ kg/m}^3 = 375 \text{ m}^3/\text{d}$
 - Secondary sludge solids (from earlier calculations)
= 2630 kg/d.
 - Secondary sludge volume = 263 m³/d.
- Total sludge volume = $375 + 263 = 638 \text{ m}^3/\text{d}$.

APPENDIX 13.2

DESIGN OF FACULTATIVE AERATED LAGOON

Design a facultative aerated lagoon to serve 40,000 people. Sewage flow @ 180 lpcd = 7200 cu.m./day, Raw BOD₅ = 50 gcd or 277 mg/l and final BOD₅ is not to exceed 30 mg/l in winter. Average ambient air temperature in January is 18 deg. C and in summer 37 deg.C.

Lagoon Size

Assume detention time =	5 days
Lagoon volume =	7200 x 5 = 36,000 cu.m.
Let Lagoon dimensions be	70 m x 130 m x 4 m deep

Lagoon Winter Temperature

Use Eq.(13.3) to determine T_L . Assume $T_c = 23^\circ \text{C}$

Hence,

$$\frac{5 \text{ days}}{4 \text{ m}} = \frac{(23 - T_L)}{0.49 (T_L - 18)} \quad \text{Hence, } T_L = 21^\circ \text{C.}$$

Estimation of K

Assume K at 20° C	=	0.7 per day
Hence, K at 21° C	=	0.7x1.035 = 0.724/day.

D/UL Estimation

Keep lagoon geometry such that flow conditions are plug-flow type (i.e. D/UL = 0.2 approx.). This will be possible if a long and narrow lagoon (23m x 390 m) is provided (see Table 13.3) or baffles are provided within the rectangular lagoon of 70 m x 130 m to give a winding flow with the same effect. (See Fig.13.5).

BOD₅ Removal Efficiency (in Winter)

$K \times \Theta = 0.724 \times 5$	=	3.62
See Fig.(13.4) at $K \times \Theta = 3.62$ and D/UL	=	0.2
Soluble BOD removal efficiency	=	92%
Namely, soluble BOD in effluent	=	22 mg/l
S.S.likely to flow out in effluent	=	35 mg/l (say)
BOD of VSS = 0.77 (0.6 x 35)	=	16 mg/l
Hence, BOD of effluent = 22 + 16	=	38 mg/l
Overall efficiency in winter	=	86%

In other months of the year, the efficiency will be higher and effluent BOD will be less than the above value.

Power Requirement

When efficiency	=	86% and all BOD is removed aerobically,
O ₂ required/day	=	0.86 (1.4 x 2000 kg/d).
	=	2,408 kg/d = 100 kg/hr.
Power needed	=	$\frac{100 \text{ kg/hr}}{(0.8) (2 \text{ kg O}_2/\text{KWh})}$
	=	62.5 KW (i.e. about 80 HP)
Power level in Lagoon	=	$\frac{62.5 \text{ KW} \times 1000}{36,000}$
	=	1.7 W/cu.m (acceptable)

Land Requirement

Net lagoon area	=	9000 sq.m.
Area including embankments and slopes	=	13,500 sq.m. (approx)
Area/person	=	0.337 sqm/person

NOTE: If the lagoon was kept as a square shaped unit or a rectangular unit with say W:L = 1:2, the D/UL value would have been between 3.0 and 4.0 (namely, approaching completely - mixed conditions) and soluble effluent BOD would have increased to 49 mg/l, thus giving a total final effluent of about 65 mg/l instead of 38 mg/l seen above. Thus, lagoon geometry plays an important part in determining efficiency.

APPENDIX 14.1

DESIGN OF TRICKLING FILTER

Problem Statement:

Design a high rate trickling filter plant to treat settled domestic sewage with a BOD_5 of 200 mg/l for an average flow of 50 MLD. Assume a peak factor of 2.25. The desired BOD_5 of effluent is 10 mg/l.

Solution:

Several design approaches are available for the design of trickling filters. Two approaches will be used to design the trickling filter viz. (i) NRC equation and (ii) Rankine's approach.

Since the BOD_5 removal efficiency is high a two stage filtration system has to be used. The design of filters is done on the basis of average flow. However, the hydraulic design of the distribution arms, under drainage system, pipelines etc., is done for peak flow and checked for average flow.

i) Design Using NRC Equation

Assuming a BOD loading of 0.8 kg BOD_5 applied/ m^3 /d excluding recirculation, the volume of first stage filter,

$$\begin{aligned} \text{Volume} &= \frac{\text{BOD}_5 \text{ load}}{\text{BOD}_5 \text{ loading}} = \frac{50 \times 200}{0.8} \\ &= 12,500 \text{ m}^3 \end{aligned}$$

The efficiency of first stage filter using NRC equation,

$$E_1 = \frac{100}{1 + 0.44 \sqrt{\frac{W_1}{V_1 F_1}}}$$

Adopting a recirculation ratio of 2.

$$F_1 = \frac{1 + R_1}{(1 + 0.1R_1)^2} = \frac{1 + 2}{(1 + 0.1 \times 2)^2} = 2.0833$$

$$W_1 = 50 \times 200 = 10,000 \text{ Kg } BOD_5/d$$

$$E_1 = \frac{100}{1 + 0.44 \sqrt{\frac{10,000}{12,500 \times 2.0833}}} = 78.6\%$$

The efficiency of second stage filter, E_2

$$E_2 = \frac{200 - 10}{200} \times 100 = 78.6 = 16.4\%$$

The volume of second stage filter can be computed using the equation

$$E_2 = \frac{100}{1 + \frac{0.44}{(1 - E_1)} \sqrt{\frac{W_1(1 - E_1)}{V_2 F_2}}}$$

Adopting a recirculation ratio of one, the value of F_2 is

$$F_2 = \frac{1 \cdot R_2}{(1 + 0.1R_2)^2}$$

$$\frac{1 \cdot 1}{(1 + 0.1 \times 1)^2} = 1.653$$

$$16.4 = \frac{100}{1 + \frac{0.44}{(1 - 0.786)} \sqrt{\frac{10,000(1 - 0.786)}{V_2 \times 1.653}}}$$

$$V_2 = 274.8 \text{ m}^3$$

ii) Rankine's Approach

Adopting an organic loading of 0.8 Kg BOD/m²/d as assumed in earlier case, the volume of first stage filter is 12,500 m³

Adopting a filter depth of 1.5 m,

Filter area needed

$$= \frac{12,500}{1.5} = 8333m^2$$

using a circular filter,

$$dia = \sqrt{\frac{8333 \times 4}{\pi}} = 102.99m$$

Since rotary distributors are available indigenously only upto 60 m, it is desirable to have a least three units.

$$= \sqrt{\frac{8333 \times 4}{3 \times \pi}} = 59.48m$$

Say 60 m

Applying Rankine's formula for the first stage filter and varying value of $R_1 = 0.5, 0.75, 1.0, 1.5, 2.0, 2.5$ and 3.0 efficiency of first stage filter can be calculated by Rankine's equation.

$$E_1 = \frac{1 + R_1}{1.5 + R_1}$$

giving values of 75; 77.78; 80; 83.33; 85.77; 87.50 and 88.88 % respectively.

These values are entered in column 2 & 3 of Table 1 respectively.

Similarly the efficiency of second stage Filter

$$E_2 = \frac{1 + R_2}{2 + R_2}$$

Various values of R_2 and efficiencies are entered in columns 5 and 6 of Table 1. Column 4 gives the BOD_5 passing through the first stage filter.

Now, the combined efficiency of the filters required to give an effluent BOD_5 of 10 mg/l.

$$\text{Efficiency of two stage } E_c = E_1 + E_2 (1 - E_1)$$

For a R_1 value of 0.5 this will be,

$$0.95 = 0.75 + E_2 (1 - 0.75) \text{ or } E_2 = 0.8$$

R_2 value from col.5 of Table = 3.0

Similarly R_2 values for various E_2 values for different R_1 values to obtain 95% efficiency are given in col.7 of Table 1.

TABLE 1
 R_2 VALUES FOR DIFFERENT VALUES OF E_2 AND R_1 TO OBTAIN 95% EFFICIENCY

S.No.	R_1	E_1	S_4	R_2	E_2	R_2
	Recirculation Ratio of 1st stage filter	Efficiency of 1st stage filter.	BOD ₅ passing through 1st stage filter.	Recirculation Ratio of 2nd stage filter.	Efficiency of 2nd stage filter	Values for various R_1 values to give 95% Efficiency.
1.	0.50	75.00	50.00	0.50	60.00	3.00
2.	0.75	77.78	44.44	0.75	63.64	2.50
3.	1.00	80.00	40.00	1.00	66.67	2.00
4.	1.50	83.33	33.33	1.50	71.43	1.50
5.	2.00	85.77	28.66	2.00	75.00	1.00
6.	2.50	87.50	25.00	2.50	77.78	0.50
7.	3.00	88.88	22.22	3.00	80.00	

The hydraulic loadings for different values of R_1 in terms of Kld/m^2 for the average flow.

$$= \frac{50 \times 10^6}{3 \times 10^4} \times \frac{4}{100(60)^2} \times (1+R_1) \text{ is worked out.}$$

$$= 5.89226 \times (1 + R_1)$$

R_1	Hydraulic Loading ($\text{m}^3/\text{d}/\text{m}^2$)
0.50	8.84
0.75	10.31
1.00	11.78
1.50	14.73
2.00	17.68
2.50	20.62
3.00	23.57

Choose $R_1 = 2$ for First Stage Filter and

$R_2 = 1$ for Second Stage Filter.

Organic loading (Recirculation included) for 3 filters of dia. 60m and depth 1.5 m

$$\frac{50 \times 10^6 \times (200 \cdot 2 \times 28.66)}{10^3} \times \frac{4}{3\pi \times 60^2 \times 1.5}$$

$$= 1010.80 \text{ g/d/m}^3$$

This is less than 1800 g/d/m³ and therefore the equations are applicable.

Choosing an organic loading 0.5 Kg/d/m²

$$= \frac{50 \times 28.66}{0.5} = 2866 \text{ m}^3$$

Adopting a depth of 1.0 m

Area of filter = 2866 m²

Check for hydraulic loading

$$\frac{50.00 \times 10^3 \times 1 \times (1 \times 1)}{2866} = 34.89 \frac{\text{Kld}}{\text{m}^2}$$

Which is more than permissible.

Therefore area required for maximum permissible hydraulic loading of 30 Kld/m²

$$= 50 \times 10^3 \times \left[\frac{(1+1)}{(30)} \right] = 3333.33 \text{ m}^2$$

Adopting 3 circular Filters,

$$dia = \sqrt{\frac{3333.33 \times 4}{3\pi}} = 37.6 \text{ m} = 38 \text{ m}$$

Adopting 3 units of 38 m dia and 1.0 m depth for 2nd Stage Filter.

iii) Hydraulic Design of First Stage Filter

This is designed for the peak flow + the recirculation of the average flow at the rates prescribed. In this case the recirculation is 2 times the average flow.

Total flow through the filters at the peak flow with 2.25 peak factor

$$= 50 \times 2.25 + 2 \times 50 = 212.5 \text{ Mld or } 2.459 \text{ m}^3/\text{s}$$

This flow is divided into 3 units

Therefore flow through each unit at peak flow = $0.82 \text{ m}^3/\text{s}$

Adopting a velocity of 2 m/s , dia of central column

$$\sqrt{\frac{0.82 \times 4}{\pi \times 2}} = 0.722 \text{ m}$$

provide a central column = 0.75 m

check for velocity at average flow:

Ave. Flow = $50 \times 10^6 \times (1+2) = 150 \text{ Mld} = 1.736 \text{ m}^3/\text{s}$

Therefore velocity at average flow =

$$\frac{1.736}{3} \times \frac{4}{\pi \times (0.75)^2} = 1.31 \text{ m/s} (> 1 \text{ m/s})$$

Distributor:

Assuming rotary reaction spray type distributor with 4 arms:

$$\text{Discharge per arm} = \frac{0.82}{4} = 0.205 \text{ m}^3/\text{s}$$

Dia of filter = 60 m

Arm length = $[(60 - 2) / 2] = 29 \text{ m}$ with 4 sections of 7.25 m each

The flow in the arms has to be adjusted for every section of 7.25 m length in the proportion of the areas covered by these lengths of the arm. Therefore, the areas covered by the different lengths of the arms are calculated.

Let A_1 , A_2 , A_3 and A_4 be the areas covered by each length of arm starting from the centre. Allowing for 0.75 m dia in centre to be used up for central column etc., the areas are

$$A_1 = \pi (7.625^2 - 0.375^2) = 182.29 \text{ m}^2$$

$$A_2 = \pi (14.875^2 - 7.625^2) = 512.68 \text{ m}^2$$

$$A_3 = \pi (22.125^2 - 14.875^2) = 843.07 \text{ m}^2$$

$$A_4 = \pi (29.375^2 - 22.125^2) = 1173.46 \text{ m}^2$$

The proportionate area for each length of arm 1st i.e. from column to 7.625 m.

$$= \frac{A_1}{A_1 + A_2 + A_3 + A_4} = \frac{182.29}{2542.17} = 6.72 \%$$

Similarly	2nd	18.91%
	3rd	31.09%
	4th	43.28%

Orifices:

Assuming a dia of 25mm for the orifices with Cd value of 0.6 and head causing flow equal to 1.5 m

$$\text{discharge through each orifice} = C_d \times A \sqrt{2gh}$$

$$= 0.6 \times \frac{\pi}{4} \times 0.025^2 \times \sqrt{2 \times 9.81 \times 1.5}$$

$$= 0.001597 \text{ m}^3/\text{s}$$

Therefore No. of Orifices required in each arm

$$= \frac{\text{Total discharge through arm}}{\text{Discharge through each orifice}}$$

$$= \frac{0.205}{0.001597} = 128.36 \text{ say } 129$$

No. of orifices in each section of the arm is

1st section	$(6.72 / 100) \times 129$	=	9
2nd section	$(18.91 / 100) \times 129$	=	25
3rd section	$(31.09 / 100) \times 129$	=	40
4th section	$(43.28 / 100) \times 129$	=	56

Spacing of Orifices:

1st Section	9 Nos.	in 725 cm i.e. 725/9	=	80cm c/c
2nd Section	25 Nos.	in 725 cm i.e. 725/25	=	29cm c/c
3rd Section	40 Nos.	in 725 cm i.e. 725/40	=	18cm c/c

4th Section 56 Nos. in 725 cm i.e. $725/56 = 13\text{cm c/c}$

Diameters of different sections of the arm:

The flow through velocity in the arm should be less than 1.2 mps

a) **Discharge through 1st section = $0.205\text{ m}^3/\text{s}$**

Crosssectional area with 1.2 mps = $(0.205 / 1.2) = 0.1708\text{ m}^2$

Assuming circular section, dia of pipe

$$\sqrt{\frac{0.1708 \times 4}{\pi}} = 0.466\text{m say } 470\text{mm}$$

b) **Discharge through 2nd section**

= $(1 - 0.0672) \times 0.205 = 0.1912\text{ m}^3/\text{s}$

For $V = 1.2\text{m/s}$

$$\text{dia} \sqrt{\frac{0.1912 \times 4}{1.2 \times \pi}} = 0.45\text{m say } 450\text{mm}$$

c) **Discharge through 3rd section**

= $[1 - (0.0672 + 0.1891)] \times 0.205 = 0.1525\text{ m}^3/\text{s}$

For $V = 1.2\text{m/s}$

$$\text{dia} \sqrt{\frac{0.1525 \times 4}{1.2 \times \pi}} = 0.402\text{m say } 400\text{mm}$$

d) **Discharge through 4th section**

= $0.4328 \times 0.205 = 0.0887\text{ m}^3/\text{s}$

For $V = 1.2\text{ m/s}$

$$dia = \sqrt{\frac{0.0887 \times 4}{1.2 \times \pi}} = 0.3067m \text{ say } 310mm$$

Under Drainage System:

Total discharge through each filter at peak flow = $0.82m^3/s$.

The underdrainage system is designed with a peripheral collecting channel fed by semi circular laterals placed at 0.6 m c/c with a slope of 2.5% in each half circle. The invert level of all laterals at their junction with the peripheral main collecting channel is kept the same R.L.

Average discharge per lateral:

$$= \frac{0.82}{100 \times 2} = 0.0041 m^3/s$$

$$ar^{2/3} = \frac{nq}{S^{1/2}} = \frac{0.015 \times 0.0041}{0.025^{1/2}} = 0.000389$$

The laterals are designed to flow half full to provide for proper ventilation.

i.e.

$$\frac{a}{A} = 0.25 ; \quad q = \frac{q}{d_o^2} = \frac{\pi}{4} \times 0.25 = 0.1963$$

From Appendix 26

for (a / d_o^2) of 0.1963 : $(ar^{2/3} / d_o^{5/3}) = 0.05915$

$$d_o = 0.152 m$$

adopting 16 cm dia

$$(ar^{2/3} / d_o^{5/3}) = (0.000389 / 0.16^{5/3}) = 0.051$$

From Appendix 26

corresponding $(a / d_o^2) = 0.1753$

$$\text{Velocity} = \frac{0.0041}{0.1753 \times 0.16^2} = 0.9136 m/s \text{ (} > 0.75 m/s \text{ required)}$$

Check for Velocity at Average Flow:

$$\text{Total discharge} = 50 + 2 \times 50 = 150 \text{ Mld} = 1.736 m^3$$

$$\text{Flow through each filter} = \frac{\dots}{3} = 0.579 \text{ m}^3/\text{s}$$

$$\text{Average flow per lateral} = [0.579 / (100 \times 2)] = 0.00290 \text{ m}^3/\text{s}$$

$$ar^{2/3} = \frac{0.015 \times 0.0029}{0.025^{1/2}} = 0.000275$$

$$\text{and } \frac{ar^{2/3}}{d_o^{8/3}} = \frac{0.000275}{(0.16)^{8/3}} = 0.0365$$

$$\text{corresponding } (a / d_o^2) = 0.1379$$

$$\therefore \text{ Velocity} = [0.0029 / (0.1379 \times 0.16^2)] = 0.8215 \text{ m/s } (>0.6 \text{ m/s required})$$

The laterals are covered with perforated blocks capable of withstanding the load of the filter media. It should be ensured that there is at least 15% of the total filter area available in the form of inlet openings for the flow into the laterals to ensure proper ventilation.

In the present design the total surface area of the laterals at the floor level of the filter is about 20% of the filter area. Therefore it is to be provided with cover blocks having about 75% openings so that inlet area available is about 15% of the filter area.

DESIGN OF MAIN COLLECTION CHANNEL

It is desirable to provide the main collection channel along the periphery of the filter. The flow is divided into two and the flow from each semi circle is collected in the peripheral main channel which is laid to a constant slope of 0.5%. The filter can be divided into four segments and the main channel checked to see if free fall conditions exist while flow from the laterals of each segment falls into it.

To provide a free fall from the invert of the laterals assume the depth of flow to be 5% less than depth of semicircular section.

$$\text{i.e. } \frac{y}{d_o} = \frac{0.95}{2} = 0.475$$

1st Segment:

$$q = 0.1 \times 0.82 = 0.082 \text{ m}^3/\text{s}$$

from Appendix 26

$$\text{for } (y / d_o) = 0.475:$$

$$(ar^{2/3} / d_o^{8/3}) = 0.1426$$

&

$$(a / d_o^2) = 0.3677$$

for a slope of 0.5% and $n = 0.015$

$$ar^{2/3} = \frac{nq}{S^{1/2}} = \frac{0.015 \times 0.082}{0.005^{1/2}} = 0.01739$$

$$d_o = [(0.01739) / (0.1426)]^{3/8} = 0.4543 \text{ m}$$

Adopting 46 cm or 0.46 m dia & 0.5% slope

$$\frac{ar^{2/3}}{d_o^{8/3}} = \frac{0.01739}{(0.46)^{8/3}} = 0.1379$$

And for this $(y / d_o) = 0.4658$ and $(a / d_o^2) = 0.3585$

$$\text{Velocity} = \frac{0.082}{0.3585 \times 0.46^2} = 1.08 \text{ m/s (> 0.75 m/s required)}$$

2nd Segment:

$$q = 0.25 \times 0.82 = 0.205 \text{ m}^3/\text{s}$$

vertical depression at the end of the 2nd section

$$= (\pi D / 4) \times (0.5 / 100) = [\pi \times (60 / 4) \times (0.5 / 100)] = 0.24 \text{ m}$$

Total additional flow in this section

$$0.15 \times 0.82 = 0.123 \text{ m}^3/\text{s}$$

Flow that can be accommodated

$$= 0.24 \times 0.46 \times 1 = 0.1104 \text{ m}^3/\text{s (Assuming 1 m/s velocity)}$$

Hence choose a bigger section say 53 cm.

Redesign of 1st Segment:

$$ar^{2/3} = 0.01739$$

$$\frac{ar^{2/3}}{d_o^{8/3}} = \frac{0.01739}{(0.53)^{8/3}} = 0.09453$$

For this value, $(a / d_o^2) = 0.27$ and $(y / d_o) = 0.3778$

$$\text{Velocity} = \frac{0.082}{0.27 \times 0.53^2} = 1.081 \text{ mps (> 0.75 mps required)}$$

Check for Average Flow (Recirculation included)

Flow in Segment 1,

$$= (1.736 / 3) \times 0.1 = 0.0579 \text{ m}^3/\text{s}$$

$$\frac{ar^{2/3}}{do^{8/3}} = \frac{0.0579 \times 0.015}{0.005^{1/2}} \times \frac{1}{(0.53)^{8/3}} = 0.06676$$

for this $(a / d_o^3) = 0.2113$ and $(y / d_o) = 0.314$

$$\text{Velocity} = \frac{0.0579}{0.2113 \times 0.53^3} = 0.9755 \text{ mps (} > 0.75 \text{ mps required)}$$

2nd Segment:

$$q = 0.205 \text{ m}^3/\text{s}$$

$$ar^{2/3} = \frac{0.205 \times 0.015}{0.005^{1/2}} = 0.04349$$

$$\frac{ar^{2/3}}{do^{8/3}} = \frac{0.04349}{(0.53)^{8/3}} = 0.2364$$

For this value, $(a / d_o^3) = 0.541$ and $(y / d_o) = 0.65$

$$\text{Velocity} = \frac{0.205}{0.541 \times (0.53)^3} = 1.349 \text{ mps}$$

$$\text{Depth of Flow} = 0.65 \times 0.53 = 0.3445 \text{ say } 0.35\text{m}$$

Depth from invert of channel to invert of lateral =

$$\frac{0.53}{2} + 0.24 = 0.5\text{m}$$

Clearance = $0.5 - 0.35 = 0.15$ m ensuring free flow conditions

3rd Segment:

$$q = 0.4 \times 0.82 = 0.328 \text{ m}^3/\text{s}$$

Assuming depth of flow above semi circular section to be x

$$r = \frac{d}{p} = \frac{\frac{\pi R^2}{2} + 0.5x}{\pi R + 2x}$$

$$\frac{0.1104+0.5x}{0.8324+2x}$$

$$0.328 = \frac{1}{0.015} (0.1104+0.5x) \left(\frac{0.1104+0.5x}{0.8324+2x} \right)^{2/3} x (0.005)^{1/2}$$

or

$$\frac{(0.1104+0.5x)^{5/3}}{(0.8324+2x)^{2/3}} = 0.06958$$

solving $x = 0.225$ and depth of Flow = $0.265 + 0.225 = 0.49$ magainst available depth of $0.265 + 0.36 = 0.625$ m which ensures free flow conditions.**4th Segment:**

$$q = 0.5 \times 0.82 = 0.41 \text{ m}^3/\text{s}$$

Let y be depth of flow above semi circular section,
then as in 3rd segment.

$$r = \frac{a}{p} = \frac{(0.1104+0.5y)^{5/3}}{(0.8324+2y)^{2/3}}$$

$$\frac{0.41 \times 0.015}{(0.005)^{\frac{1}{2}}} = 0.08697$$

solving by trial and error, $y = 0.315\text{m}$

Depth of Flow = $0.265 + 0.315 = 0.58\text{m}$

against available depth of = $0.265 + 0.48 = 0.745\text{m}$ ensuring free flow condition

$$\text{Velocity} = \frac{0.41}{0.1104 + 0.1575} = 1.53 \text{ mps}$$

Design of Exit Channel

$q = 0.82 \text{ m}^3/\text{s}$ for each filter.

Assuming a channel of rectangular section with a slope of 0.5%

$p = 2d+w$ and $A = wxd$, $r = (A / p)$ or $[r / (w + 2d)] = [(w \times d) / (w + 2d)]$

$q = [(1 / n) ar^{2/3} S^{1/2}]$; $0.82 = (1 / 0.015) \times w \times d \times [(w \times d) / (2d + w)]^{2/3} \times (0.005)^{1/2}$

or

$$\frac{(wxd)^{\frac{5}{3}}}{(2d+w)^{\frac{2}{3}}} = 0.174$$

or

$$\frac{(wxd)^5}{(2d+w)^2} = 0.005268$$

Assuming a depth of 0.45m of exit channel, by trial & error

$w = 1.05 \text{ m}$

If width w of channel is 1.1 m, then depth of flow of channel d by trial & error.

$$\frac{(1.1 \times d)^5}{(2d + 1.1)^2} = 0.005268 \quad \text{we get } d = 0.415 \text{ m}$$

518 (A)

APPENDIX - 14.1

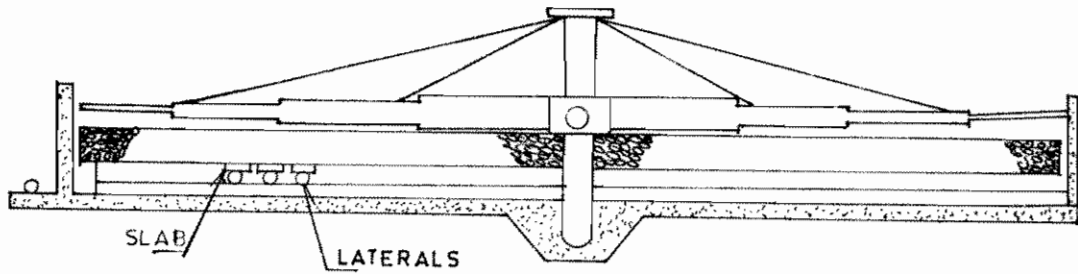

SECTION

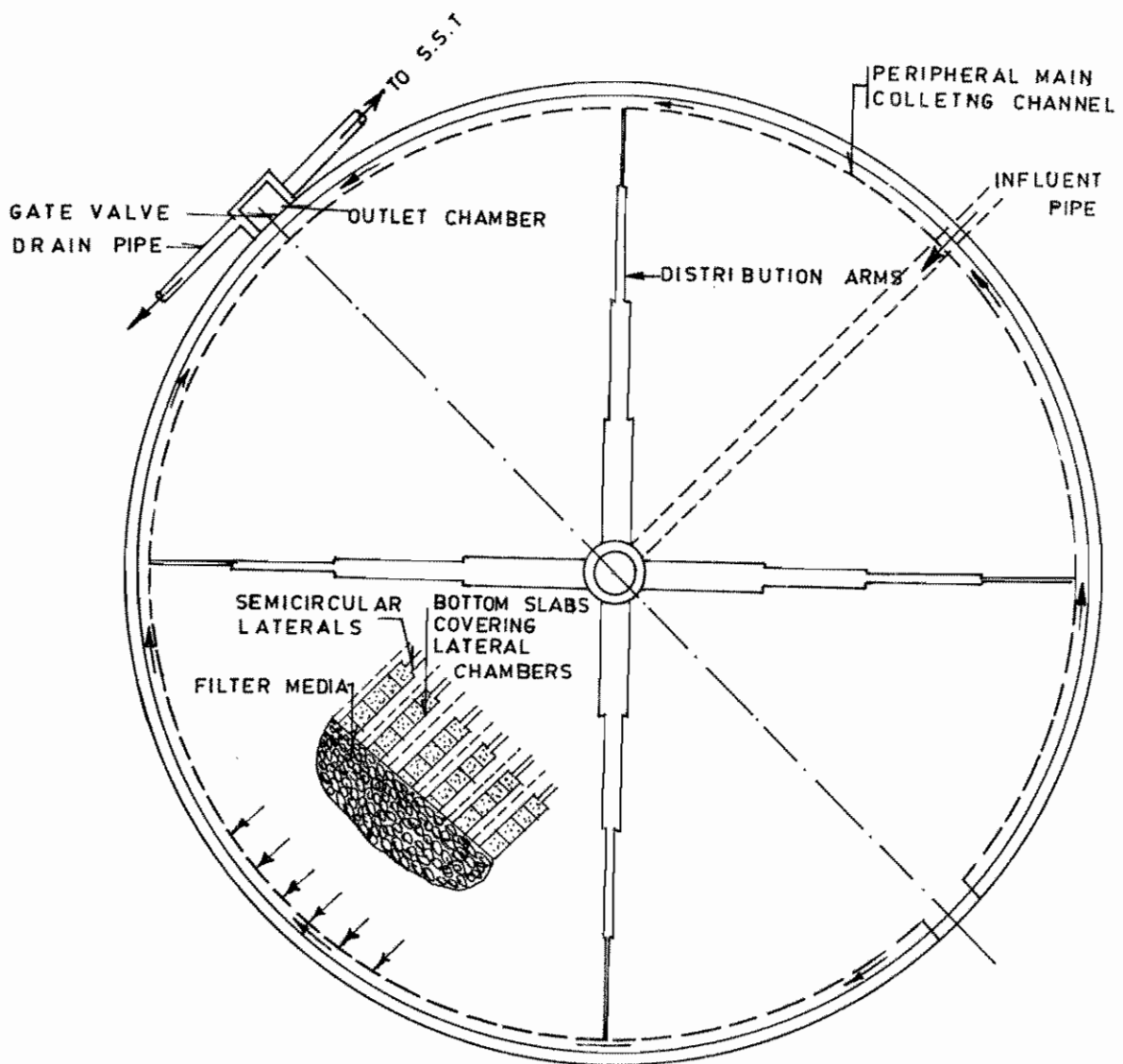

PLAN

TYPICAL DETAILS OF TRICKLING FILTER



therefore effluent channel from each filter will be of size 1.1m x 0.45m with 0.5% slope.

Ventilation:

Since the filter is large having a dia of 60m, provision for open grating area to be made at 1/250 of the filter area.

$$\text{Area of grating needed} = [(\pi \times 60^2) / (4 \times 250)] = 11.32 \text{ m}^2 \text{ say } 12 \text{ m}^2$$

Therefore provide 12 Nos. of gratings of size 4m x 0.25m providing a total of 12 m² ventilation area.

2nd Stage Filter:

The details of Second Stage Filter are also worked out on similar lines.

APPENDIX 14.2

DESIGN EXAMPLE OF ROTATING BIOLOGICAL CONTACTOR

Problem Statement:

Design rotating biological contactor modules to treat 50,000m³/d of primary settled sewage with the following assumptions:

Hydraulic loading rate	=	110 l/m ² .d
Diameter of the discs	=	3.5 m
Centre to centre spacing between discs.	=	20 mm

Solution:

$$\begin{aligned} \text{i) Total surface area of discs} &= \frac{\text{Flow}}{\text{Hydraulic loading rate}} \\ &= \frac{50,000 \times 10^3}{110} = 454545.5 \text{ m}^2 \end{aligned}$$

$$\begin{aligned} \text{ii) Surface area of One discs} &= \frac{\pi \times (3.5)^2 \times 2}{4} \\ \text{(neglecting the thickness)} &= 19.24 \text{ m}^2 \end{aligned}$$

$$\text{iii) Number of discs} = \frac{454545.5}{19.24} = 23625$$

$$\text{iv) Minimum length of shaft on which discs are mounted} = 23625 \times 0.02 = 472.5 \text{ m}$$

v) Provide 40 modules of 12 m length with 23625 discs.

vi) Hydraulic residence time assuming 50% submergence of discs:

$$= \frac{(\pi / 4) \times (3.5 + 0.1)^2 \times 40 \times 12 \times 24 \text{ hrs} \times 0.5}{50,000} = 1.17 \text{ hours}$$

APPENDIX 15.1

DESIGN EXAMPLE OF FACULTATIVE STABILIZATION POND

Design a facultative stabilization pond to treat 5000 m³/d municipal wastewater, BOD₅ 230 mg/l, from a town (population 25,000 persons) located in Central India, latitude 22 deg.N, elevation 100 m above sea level. The average temperature in January is 18° .C. The effluent from the pond is to be used for irrigation.

Solution :**Pond Size:**

Permissible organic load according to temperature correlation = $20 \times 18 - 120 = 240$ kg BOD/ha.d

Permissible organic load according to latitude and elevation = $235 / (1 + 0.003 \times 100) = 180$ kg BOD/ha.d

Adopt a conservative loading rate of 200 kg BOD/ha.d

BOD load from the town = $5000 \times 0.23 = 1150$ kg/d

Therefore pond area = $1150 / 200 = 5.75$ ha

Adopt an average depth of 1.5 m

Therefore pond detention time = $5.75 \times 10^4 \times 1.5 / 5000 = 17.25$ d.

Provide three ponds of equal volume and surface area; two primary ponds in parallel and one secondary pond in series receiving the effluent of the two primary ponds. Use of multiple ponds improves performance from view points of stability, efficiency of treatment and maintenance. However, it requires greater land area for the same pond surface area.

Check for Detention Time:

For 90% BOD reduction, the BOD reaction rate constant = 0.2/d for plug flow condition. The total overall detention time, Θ , is given by:

$$0.1 = \exp - 0.2 (2 \times \Theta/3 + \Theta/3), \text{ or } \Theta = 11.5 \text{ d}$$

For a conservative estimate, for completely mixed condition in all three ponds, the total overall detention time is given by:

$$0.1 = 1 / (1 + 0.2 \times 2 \Theta/3) (1 + 0.2 \times \Theta/3), \text{ or } \Theta = 22.5 \text{ d}$$

In actual conditions the hydraulic regime in the ponds is going to be between the two ideal conditions of plug flow and completely mixed flow. The detention time of 17.25 d is therefore acceptable.

Check for Microbial Quality for Irrigation

WHO guidelines recommend sewage retention in stabilization ponds for 8 - 10 days for irrigation of cereal, fodder and industrial crops and trees. This assures removal of intestinal nematodes from sewage. The design meets this requirement.

For irrigation of crops likely to be eaten uncooked, the guide lines recommend a faecal coliform limit of 1000 organisms/100 ml. For microbial reduction rate constant of 2.0/d at 20° C or 1.4 at 18° C, and influent faecal coliform concentration = $10^7/100$ ml, the effluent concentration N is given by

$$N = 10^7 / (1 + 1.4 \times 2 \times 17.25/3) (1 + 1.4 \times 17.25/3)$$

or

$$N = 64,600/100 \text{ ml}$$

Therefore the design does not meet the criteria of irrigation water quality for crops likely to be eaten uncooked. If two maturation ponds, each of 17.25/3 d detention time are provided in series after the secondary pond, the effluent concentration is expected to be:

$$\begin{aligned} N &= 10^7 / [1 + 1.4 \times 2 \times (17.25 / 3)] (1 + 1.4 \times 17.25/3)^2 \\ &= 788/100 \text{ ml.} \end{aligned}$$

The above calculations are based on assumption of complete mixing. In actual condition the performance is likely to be better.

Sludge Accumulation:

Most of the sludge will accumulate in primary ponds. Assuming 0.75 m deep allowable sludge deposition, capacity available = $0.75 \times (2/3) \times 5.75 \times 10^4 = 28750 \text{ m}^3$. For $0.07 \text{ m}^3/\text{person}/\text{year}$ sludge accumulation rate,

$$\text{desludging frequency} = 28750 / (0.07 \times 25000) = 16 \text{ years.}$$

Because of non-uniform deposition of sludge, a desludging frequency of once in 10 years is recommended.

APPENDIX 15.1

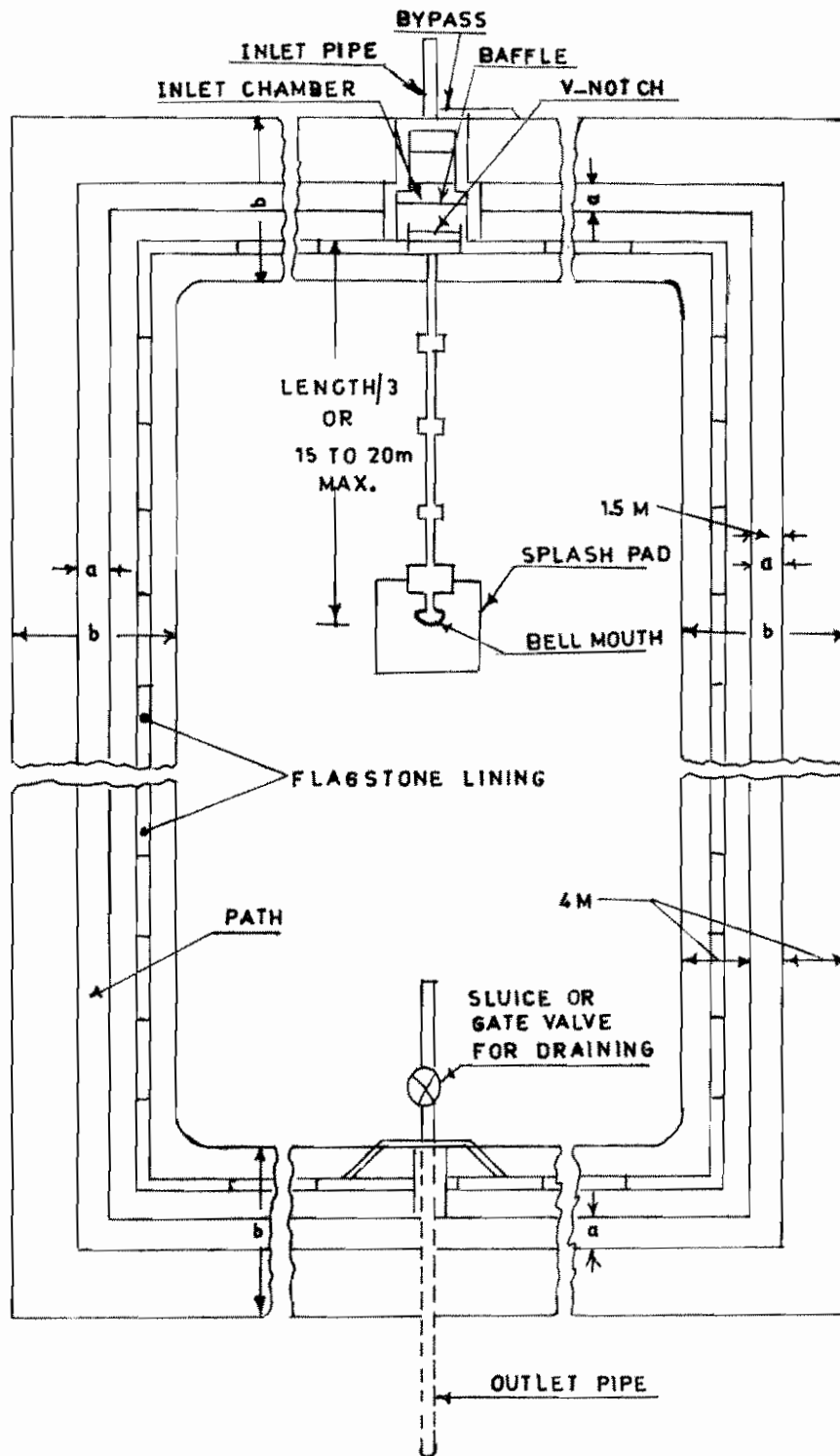

a = Top width of the bund
b = Bottom width of the bund

TYPICAL PLAN OF A WASTE STABILIZATION POND



APPENDIX_15.1

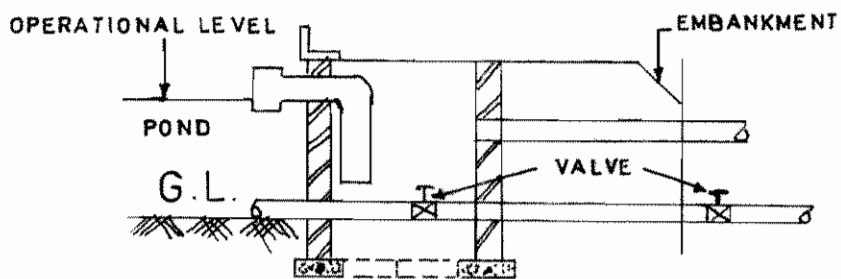
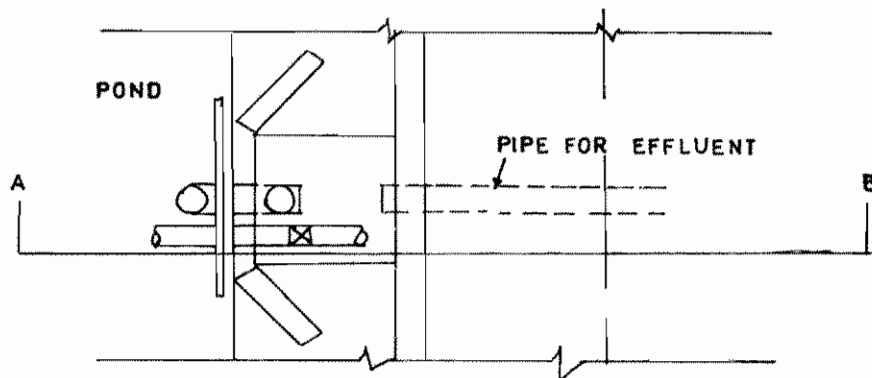
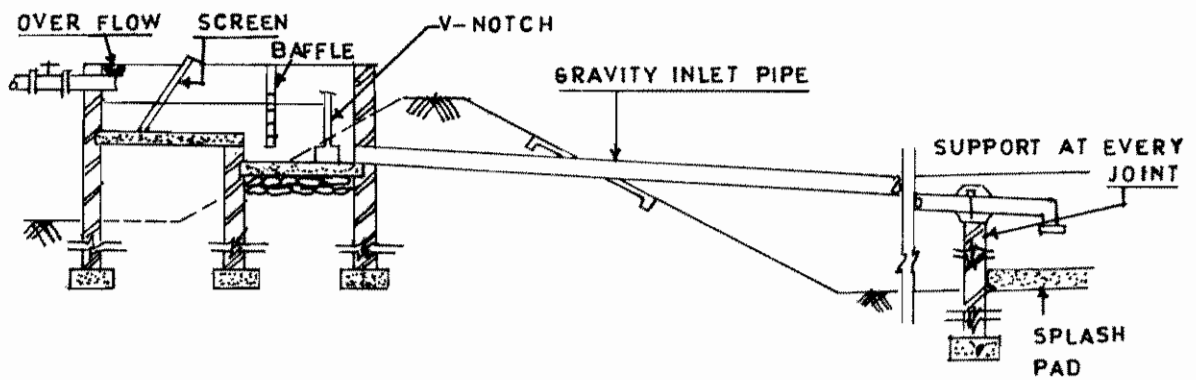
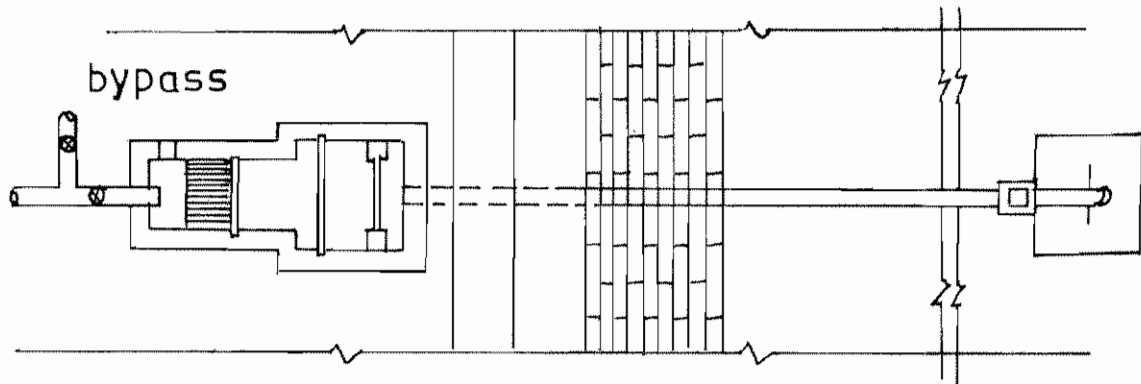

TYPICAL DETAILS OF INLET AND
OUTLET CHAMBER FOR FACULTATIVE
WASTE STABILISATION POND

APPENDIX 16.1

DESIGN EXAMPLE FOR UPFLOW ANAEROBIC SLUDGE
BLANKET REACTOR

Problem Statement

Design an upflow sludge blanket reactor for an average flow of 5 MLD of wastewater with the following data:

- | | | | |
|----|--|---|--------------------------------|
| 1. | COD of wastewater | = | 400 mg/l |
| 2. | Design hydraulic residence time | = | 6 hrs |
| 3. | Design COD loading | = | 1 - 2 kg COD/m ³ .d |
| 4. | Velocity of rise of wastewater in the reactor through sludge bed | = | 0.75 m/hr |
| 5. | Velocity of wastewater in settling chamber | = | < 1.5 m/hr |
| 6. | Flow area covered by each inlet | = | 1 - 2 m ² |

Solution

- 1 Determine the dimensions of UASBR

$$\text{Volume of UASBR} = 5000 \times (6 / 24) = 1,250 \text{ m}^3$$

$$\begin{aligned} \text{Actual volumetric organic loading} &= [(5 \times 400) / 1250] \text{ kg COD/m}^3.\text{d} \\ &= 1.6 \text{ [O.K. as it is between 1-2 kg COD/m}^3.\text{d}] \end{aligned}$$

$$\begin{aligned} \text{Height of waste water in reactor} &= \text{Rise velocity} \times \text{HRT} \\ &= 0.75 \times 6 = 4.5 \text{ m} \end{aligned}$$

$$\text{Area of Reactor} = [1250 / 4.5] = 277.8 \text{ m}^2$$

Provide two reactors of 11.8 m x 11.8m x 5.25 m (height)

2. No. of Inlets

Assume that each inlet can serve 2.0 m² of flow area

$$\text{Number of inlets in each reactor} = [138.9 / 2] = 70$$

3. Area of Settling Chamber

Assuming a velocity of 1.2 m/hr in the settling zone

$$\text{Area of settling chamber in each reactor} = [5000 / (2 \times 24 \times 1.2)] = 86.8 \text{ m}^2$$

APPENDIX 16.2

DESIGN EXAMPLE FOR ANAEROBIC FILTER

Problem Statement

Design anaerobic filters to treat an average flow of 5 MLD of wastewater with the following assumptions.

- | | | | |
|----|-----------------------|---|------------------------------|
| 1. | COD of the wastewater | = | 400 mg/l |
| 2. | Design COD Loading | = | 1.0 kg COD/m ³ .d |
| 3. | Depth of media | = | 1.2 m |

Solution

- | | | | |
|----|---------------------------------------|--------------|-------------------------|
| 1. | Dimensions of anaerobic filter | | |
| | Total COD load | = 5 x 400 | = 2000 kg COD/d |
| | Volume of anaerobic filters for media | = [2000/1.0] | = 2000 m ³ |
| | Plan Area of filters | = [2000/1.2] | = 1666.7 m ² |

Provide two filters of diameter 32.6 m and height 1.5 m including free board and bottom zone for dispersion of wastewater and supporting media.

- | | | |
|----|-----------------|-------------------|
| 2. | HRT for filters | = [2000 / 5000] d |
| | | = 9.6 hrs. |

APPENDIX 17.1

DESIGN EXAMPLE OF SLUDGE DIGESTERS

Design low rate and high rate digesters for digesting mixed primary and activated sludge from a 50,000 m³/day capacity activated sludge Wastewater Treatment Plant.

Given:

From the Appendix 13.1 on the design of activated sludge process:

- | | | | |
|----|---|---|-------------------------|
| a) | Raw effluent suspended solids (SS) concentration | = | 400 mg/l |
| b) | SS removal efficiency in the primary sedimentation tank | = | 75% |
| c) | Therefore, quantity of primary sludge generated ($0.4 \text{ Kg/m}^3 \times 50,000 \text{ m}^3/\text{day} \times 0.75$) | = | 15,000 Kg/day |
| d) | At 4% consistency or 40 Kg/m^3 SS concentration, primary sludge volume ($15000 \text{ Kgs.day} \div 40 \text{ Kg/m}^3$) | = | 375 m ³ /day |
| e) | The excess activated sludge generated | = | 2,630 Kg/day |
| f) | At 1% consistency or SS concentration of 10 Kg/m^3 the excess activated sludge volume ($2630 \text{ Kgs} \div 10 \text{ Kg/m}^3$) | = | 263 m ³ /day |
| g) | Total volume of the raw mixed sludge ($375 + 263$) | = | 638 m ³ /day |
| h) | Total quantity of the raw mixed sludge ($15,000 + 2630$) | = | 17,630 Kg/day |
| i) | SS concentration of the raw mixed sludge ($17630 \text{ Kgs/day} \div 638 \text{ m}^3/\text{day}$) | = | 27.6 Kg/m ³ |
| j) | The approximate percentage of volatile matters (VM) in the mixed sludge | = | 70 % |
| k) | Quantity of VM in the raw mixed sludge (0.7×17630) | = | 12,341 Kg/day |
| l) | Quantity of Non-VM or inorganic (0.3×17630) | = | 5,289 Kg/day |

* 1% consistency = 10,000 mg/l = 10 m³/kg

Low Rate Digester

- a) Approximate Percentage destruction of VM (design value) = 50%
- b) For achieving 50 % VM destruction, under mesophilic conditions, the HRT required (from Fig.17.3) = 40 Days
- c) Quantity of VM in the digested sludge (0.5 x 12,341) = 6,170 Kg/day
- d) Quantity of nonvolatile matters or inorganic matters in the digested sludge = 5,289 Kg/day
- e) Total quantity of solids in the digested sludge (6,170 + 5,289) = 11,459 Kg/day
- f) percentage of VM in the digested sludge (6,170 ÷ 11,459) = 53.80%
- g) percentage of inorganic matter in the digested sludge (5,289 ÷ 11,459) = 46.20%
- h) Depending on the frequency of sludge withdrawal the consistency of the digested sludge withdrawn from the low rate digester is expected to be in the range of 4 - 6 %.
- i) For an average consistency of 5 % (or 50 Kg/m³), the volume of digested sludge (11,459 ÷ 50) = 229 m³/day
- j) Therefore the volume of digester

$$\begin{aligned}
 V &= [V_i - 2/3 (V_i - V_o)] T_i \\
 &= [638 - 2/3 (638 - 229)] 40 \\
 &= 14,624 \text{ m}^3
 \end{aligned}$$

Check for volatile solids loading rate Kg VSS/day m³

$$= 12,341 \div 14,624 = 0.84 \text{ Kg VSS/Day m}^3.$$

(The VSS loading is within the permissible range - 0.6 to 1.6 Kg VSS/Day/m³)

Gas generation

Gas production per Kg of VM destroyed	=	0.9 m ³
Total gas generation (0.9m ³ /Kg VM * 6,170 KgVM/day)	=	6,039 m ³
To avoid foaming, the minimum surface area required to meet the condition - 9m ³ of gas generated per Day per m ² surface area, will be [6039÷9]	=	617 m ²
For operational flexibility and constructional reasons, it is suggested to install two digesters of the following dimensions.		
Volume of each digester [14,624 m ³ ÷ 2]	=	7,312 m ³
Minimum surface area of each digester [617 m ² ÷ 2]	=	309 m ²
Choosing the digester shape as a low, vertical cylinder and for a diameter of 34 m, the surface area of each digester will be	=	908 m ²
Therefore the effective digester depth will be { 7,312 m ³ ÷ 908 m ² }	=	8.0 M
Additional Volume		
Volume for sludge storage during the monsoon period - when the sludge drying bed option is used for sludge dewatering	=	Vd * T2
For a storage period of 12 days {229 m ³ /day * 12 days}	=	2,748 m ³
equivalent to 2748 m ³ ÷ 908 m ²	=	3.0 m
Additional allowance for grit and scum accumulation	=	0.6 m
Free board	=	0.6 m
Therefore total additional depth	=	4.2 m

TWO DIGESTERS - EACH OF 34 M DIAMETER & 12.2 M DEPTH
--

High Rate Digesters

For a sludge temperature of 20° C, the Solids Retention Time (SRT) required for 50% VSS destruction (refer Fig.17.3)	=	20 days
Therefore the digester volume will be	=	638 * 20
(Volume of fresh sludge * Retention time)	=	12760 m ³
Choosing two digesters, the capacity of each digester will be:		
Volume (12760 m ³ ÷ 2)	=	6380 m ³
Choosing a diameter of 27 M, the effective depth will be	=	11.2 M
Additional allowance for grit accumulation	=	0.5 M
Free board	=	0.6 M
Total additional depth	=	1.1 M

Two digesters of 27 M diameter and 12.3 M depth

Additional, separate sludge holding facility for storage during monsoon period (when sludge drying bed option is used for dewatering) is to be computed as before.

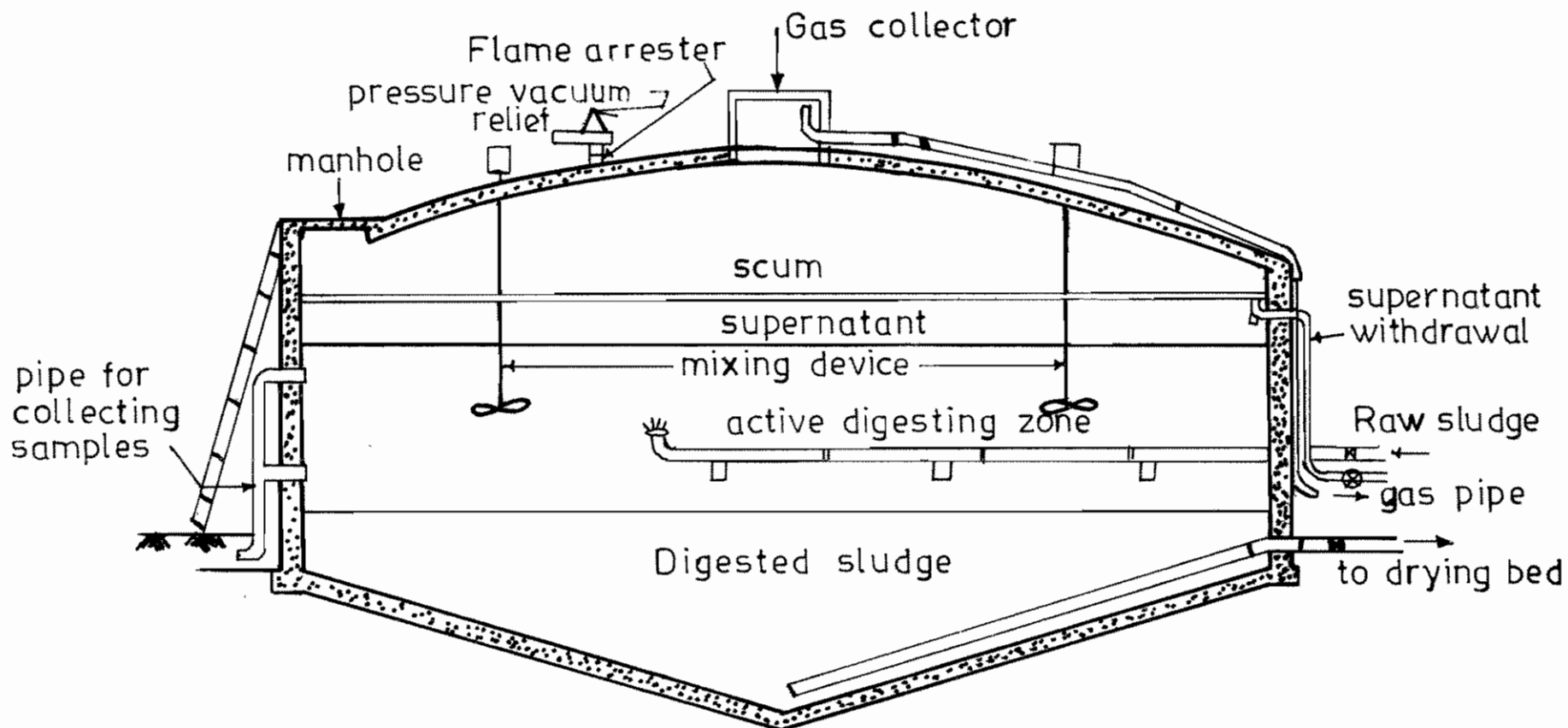

SECTION

TYPICAL DETAILS OF LOWRATE SLUDGE DIGESTER

APPENDIX 17.2

DESIGN EXAMPLE OF SLUDGE DRYING BEDS

Problem Statement

Design sludge drying beds for digested sludge obtained from low rate anaerobic digesters for digesting a mixture of primary and excess activated sludge. The capacity of activated sludge plant is 50,000 m³/d and following data is assumed:

- i) Volume of digested sludge = 229m³/d
(Refer to design example on low rate anaerobic digester in Appendix 17.1)
- ii) Dewatering, drying and sludge removal cycle = 10 d
- iii) Depth of application of sludge = 0.3 m
Solution
- a) Total plan area of sludge drying = $\frac{229 \times 10}{0.3} \text{ m}^2$
= 7633 m²
- b) Number of beds is assumed to be = 30
Plan area of each bed $\frac{7633}{30} = 254.43\text{m}^2$
- c) If per capita wastewater flow is assumed as 150 lpcd
contributory design population = $\frac{50000 \times 10^3}{150} = 3,33,333$

Plan area of sludge drying bed = $7633 \div 3,33,333 = 0.023 \text{ m}^2/\text{capita}$

APPENDIX 17.2

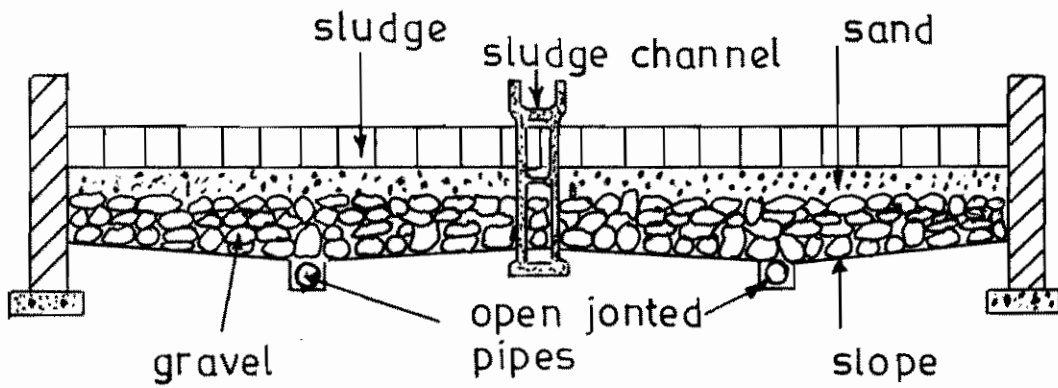

SECTION

TYPICAL DETAILS OF SLUDGE DRYING BED

APPENDIX 21.1

SOIL PERCOLATION TEST

To design a suitable soil absorption system for disposal of effluent from septic tanks, percolation tests shall be carried out, on the proposed site for location of the absorption system, in the following manner.

Six or more test holes spaced uniformly over the proposed absorption field shall be made.

A square or circular hole with side width of diameter of 10 cm to 30 cm and vertical sides shall be dug or bored to the depth of the proposed absorption trench. The bottom and sides of the holes shall be carefully scratched with a sharp-pointed instrument to remove any smeared soil surfaces and to provide a natural soil interface into which water may percolate. The holes shall be filled for a depth of 5 cm with loose material to protect the bottom from scouring and settling.

Before the actual readings for percolation tests are taken, it is necessary to ensure that the soil is given ample opportunity to swell and approach the condition it will be in during the wettest season of the year. This is done by pouring water in the hole upto a minimum depth of 30 cm over the gravel and allowed to soak for 24 hours. If the water remains in the test hole after the overnight swelling period, the depth of water shall be adjusted to 15 cm over the gravel. Then from a fixed reference point, the drop in water level shall be noted over a 30 min. period. This drop shall be used to calculate the percolation rate.

If no water remains in the hole, at the end of 30 min. period, water shall be added to bring the depth of the water in hole 15 cm over the gravel. From a fixed reference point, the drop in water level shall be measured at 30 min. intervals for 4 hours, refilling to 15 cm level over the gravel as necessary. The drop that occurs during the final 30 min. period shall be used to calculate the percolation rate. The drop during the earlier periods provide information for the possible modification of the procedure to suit local circumstances.

In sandy soils or other porous soils in which the first 15 cm of water seeps away in less than 30 minutes after overnight swelling period, the time interval between measurements shall be taken as 10 minutes and the test run for one hour. The drop that occurs in the final 10 minutes shall be used to calculate the percolation rate.

Based on the final drop, the percolation rate, which is the time in minutes required for water to fall 1 cm, shall be calculated.

APPENDIX 21.2

DESIGN EXAMPLE OF LEACH PIT

Design example : Twin Leach Pits (Dry conditions) for 5 users :

1. Assumptions :

- a) 9.5 liters of wastewater is generated per capita per day
- b) 5.0 liters of water is used per day for floor washing and pan cleaning
- c) The water table remains 2 meters or more below ground level through out the year for dry pit and 50 cm below for wet conditions
- d) The local soil is porous silty loams and
- e) The pits are designed for 2 year sludge accumulation capacity.

2. The solution.1 :

- a) Calculate the total waste water flow (Q) in liters per day

$$Q = 9.5 \text{ l/d} \times 5 \text{ users} + 5 \text{ liters for floor wash etc.,}$$

$$= 52.5 \text{ liters per day}$$

- b) Assuming a pit of 800 mm internal diameter (inside lining 75 mm thick with brick on edge and effective depth 800 mm, check for infiltrative surface area (A_i); this is given by :

$$A_i = \pi dh$$

Where d is the external diameter and h is the effective depth of the pit

$$A_i = \pi \times 0.95 \times 0.8 = 2.39 \text{ m}^2$$

- c) If the soil is porous silty loams, the infiltrative area required is $52.5/20 = 2.62 \text{ m}^2$; hence the infiltrative area provided is insufficient. Therefore by choosing a depth of 0.9 m ; the infiltrative area A_f will be

$$= \pi \times 0.95 \times 0.9 = 2.69 \text{ m}^2 \text{ , which is sufficient}$$

- d) Check for the required solid storage volume (V) for a solids accumulation rate of 0.04 m^3 per capita per year. (Table 21.4) for a dry pit with water being used for anal cleansing and for a desludging interval of 2 years and a household size of 5 persons

$$V = 0.04 \times 2 \times 5 = 0.40 \text{ m}^3;$$

Whereas, the volume of proposed pit is :

$$\frac{\pi \times 0.8 \times 0.8 \times 0.9}{4} = 0.45 m^3$$

Hence pit proposed has the sufficient storage capacity.

- e) Allowing a free space of say 0.225 m, the dimensions of the pit are as follows :

Internal diameter 800 mm
Total depth 1125 mm (900 mm + 225 mm free board)

Since the pit bottom is more than 2 m above the maximum ground water table, the pit will function in dry condition.

Solution.2 :

The ground water table is 50 cm below the ground surface, but all other assumptions are the same as in the above example.

The pit size is determined by taking the sludge accumulation rate from Table 21.4. Assuming the pit desludging period as 2 years.

$$\begin{aligned} \text{Volume of the pit} &= 0.095 \times 2 \times 5 \\ &= 0.95 \text{ Cu.M.} \end{aligned}$$

Allowing a free board of 0.225 m. Pit dimensions come as follows :

Internal diameter 1100 mm
Total depth 1225 mm (1000 mm + 225 mm free board)

APPENDIX 23.1

OPERATION TROUBLES IN SEWAGE TREATMENT PLANT

Signs & Symptoms (1)	Possible Causes (2)	Suggested Action (3)
<u>Pretreatment</u> Unusual or excessive screenings	Increase in domestic sewage or industrial waste	Clean screens more often and report
Excessive grit	Roadwashings, ashes or material from building site	Report and get them diverted.
Excessive organic matter in grit	Velocity is too low and detention period too long	Reduce the cross-sectional area of the channel occupied by flowing sewage. Install planks, bricks or tile along sides of channel or reshape or repair outlet weir to proportionally reduce depth of flow for all normal present flow rates, or decrease the number of channels used; or reduce length of channel by moving outlet weir
Carryover of Grit	Velocity is too high and detention too short.	Remove grit more frequently or increase number of channels or increase cross sectional area of channels
<u>Sedimentation Tank</u> Floating sludge in all tanks	Accumulated sludge decomposing in the tank and buoyed to the surface	Remove sludge more completely and more often
Floating sludge: not in all tanks	Affected tanks receiving too much sewage.	Reduce flow to affected tanks.
Bubbles rising in tanks.	Septic conditions	Report and empty tank completely as soon as possible
Contents black and odorous	Septic sewage or strong digester supernatant.	Take action to eliminate septicity by improving hydraulics of sewer system, pre-treatment of organic industrial wastes admitted to the system etc. or improve digester operation so as to have improved quality supernatant, or reduce flow into settling tank or bypass completely supernatant to lagoons etc. till situation improves
Excessive settling in inlet channels	Velocity too low	Reduce cross-sectional area by installing inner wall of suitable material along one wall of channel; or agitate with air, water or otherwise to prevent deposition
Excessive suspended matter in effluent all tanks	Accumulated sludge Flow through tanks too fast (over loading) Humus sludge or under drainage returned too fast	Clean tanks more often Report and get the loading reduced Reduce pumping rate
not all tanks	Some tanks receiving too much sewage	Reduce flow to affected tanks

Excessive floating matter in the effluent	Defective scum boards or none.	Repair scum boards or install new ones.
Sludge pipes choke	Sludge too thick Sludge contains grit	Clean more often Clean grit chamber more often, if chokage persists report Change sludge piping if necessary
Intermittent surging of flow	High intermittent pumping rates.	Adjust pumping rates to keep close to rates of flow or install or adjust baffling to reduce inlet velocity and to have effective flow distribution across the width of tank.
Sludge hard to remove from hopper	High content of grit and/or clay Low velocity in withdrawal line.	Reduce grit content, or reduce clay-content; or rod the clogged lines. Pump sludge more often or change sludge piping
Trickling Filters Filter ponding	Rock or other media too small or not sufficiently uniform in size Organic loading excessive.	Rake or fork the rocks or film surface with light equipment, wash the filter surface with a stream of water under high pressure, or stop the distributor over the ponded area and allow continuous flow of sewage, or dose the filter with heavy application of chlorine (5 Mg/l Cl_2 in filter influent) for several hours at weekly intervals or take the filter out of use for one day or longer to allow it to dry out or replace filter media if above methods do not succeed.
Filter Flies	Develop most frequently in an alternate wet and dry environment	Dose filter continuously not intermittently, or remove excessive biological growth; or flood the filter for 24 hours at weekly or byweekly intervals (it should be done at intervals frequent enough to prevent the fly completing its life cycle between floodings), or wash vigorously the inside of the exposed filter walls, or chlorinate the sewage (3 to 5 mg/l) for several hours at frequent intervals of 1 to 2 weeks, or apply DDT or other insecticides
Odours	Anaerobic decomposition of sewage sludge or biological growths	Maintain aerobic conditions in all units including sewer system or reduce accumulation of slime and biological growth, or chlorinate filter influent for short periods when flow is low or reduce unusually heavy organic loadings as from milk wastes

Icing of Filter Surface	Air temp at or below 0°C, or progressive lowering of temperature of applied sewage by recirculation or uneven distribution of sewage on filter	Decrease number of times sewage is recirculated, or where two stage filters are used, operate filters in parallel with little or no recirculation or adjust orifices etc., to improve uniformity of distribution over filter and to reduce spray effect or erect a wind screen at the filter in the path of prevailing winds, or break up to remove ice frequently.
Activated Sludge Change in sludge volume index	High soluble organic loads in sewage	Decrease aeration liquor suspended solids, or bulking of activated sludge may be controlled by proper application of chlorine to return sludge or control sludge index by converting digested sludge to activated sludge
Rising sludge (in settling tanks)	Due to excessive nitrification	Increase the rate of return activated sludge from the final settling tank or decrease the rate of flow of aeration liquor into the tank, or increase the speed of sludge collecting mechanism in the final settling tank to increase the rate of removal of sludge or decrease nitrification by reducing aeration or lowering the detention period
Frothing	Synthetic detergents cause frothing. The froth increases with decrease in aeration liquor suspended solids or increase in aeration or increase in degree of purification of sewage or increase in atmospheric temperature.	Use water effluent or clarified sewage sprays in the frothing areas, or apply defoamants in small quantities to tank surface (repeated dosing is necessary) or increase aeration liquor SS concentration
Sludge Digestion Fluctuation in sludge temperature		Pump large quantities of thin sludge at high rate for cooling
Temperature drops in unit with hot water coils	Sludge solids adhering to coils forming a thick insulating layer preventing heat transfer to digester	Clean the surfaces of coils or replace this form of heating with an external heat exchanger
Temperature constant gas production drops	Increase in Scum accumulation or increase in grit accumulation, or excessive acid production or acid condition due to (a) Organic over loading. (b) Acid Wastes (c) Toxic metals Cu Ni Cr & Zn	Control scum or control grit or prevent excessive acid conditions by reducing organic overloads or reduce acid wastes by pretreatment, or eliminate toxic metals or add lime to keep pH between 6.8 to 7.2 or proper quantity of over digested sludge should be withdrawn from digester

Foaming	Insufficient amount of well buffered sludge in the digester; or excessive additions of raw sludge (with high volatile content); or poor mixing of digester contents; or temperature too low for prolonged periods followed by rise in temperature of digester contents; or withdrawal of too much digested sludge; or excessive scum or grit accumulations	Temporarily reduce or stop raw sludge additions; or add lime to keep pH between 6.8 to 7.2 while other corrective measures are undertaken; or restore good mixing within digester; or raise temperature to normal range; or breakup and remove excessive scum layer; or if large quantities of oil or grit are present, empty digester.
<p>Sludge Drying Beds</p> <p>Sludge dries more slowly than usual</p>	<p>Sludge layer too thick</p> <p>Second dose applied too late</p> <p>Standing water</p> <p>Bed surface clogged</p> <p>Broken or clogged drains</p>	<p>Put on less sludge</p> <p>Do not apply second dose if first has started to dry off</p> <p>Decant water</p> <p>Rake over skim if necessary and redress the surface.</p> <p>Set them right.</p>

APPENDIX 23.2

(1)
SCHEDULE OF PREVENTIVE MAINTENANCE
Centrifugal Pumps

Sl. No	Name of Section or part to be attended.	Maintenance to be carried out	Frequency/time interval at which inspection and maintenance to be done	Remarks
1	Bearings	Checking of Temperature with thermometer	Two months	Hot ball or roller bearings point to too much oil or grease. hot sleeve bearings need more oil or heavier lubricant. If does not correct, disassemble and inspect the bearing alignment of pump and driver
2.	Glands	Changing of Gland packing	Two months	
3	Bearings	Lubrication (greasing)	Two months	Check for saponification resulting in whitish colour, washout with kerosene
4.	Gauges	Checking of pressure and vacuum gauges	Three months	
5	Valves	Changing of gland packing in delivery sluice valve suction valves, bye pass valve, reflux valve	Six months	
6	Exhaust pump and its auxiliaries	Checking of gland packing & its auxiliaries etc	Six months	
7.	Impeller	Checking of impeller blades sleeves, efficiency rings bearings neck ring impeller nut etc	Year	

(2)
SCHEDULE OF PREVENTIVE MAINTENANCE
Electrical Motors

S No.	Name of Section or part to be attended	Maintenance to be carried out	Frequency/ time interval at which inspection and maintenance to be done	Remarks
1.	Induction Motor stator and Rotor	Opening of end covers dust blowing and checking of air gap	One month	Depending on the working conditions & maintenance staff available
2.	Slip ring device	Cleaning of slip rings and adjustment of carbon brushes short circuiting jaws, oiling of clutch etc.	One month	
3	Bearings	Proper lubrication	Two months	
4.	Windings	Checking of motor after taking out its Rotor dust blowing checking of end connections of stator Rotor and taking insulation test no load test before putting the motor on load	Two years	

(3)

SCHEDULE OF PREVENTIVE MAINTENANCE
Power Transformer

Sl. No.	Maintenance to be carried out	Frequency/time interval at which inspection & maintenance to be done	Remarks
1.	Checking of silica gel, topping of transformer oil, temperature gauge, vent pipe, voltage tap changing switch	Six months	Check and if required silica gel must be changed before the outbreak of monsoon
2.	Filtration of oil, checking of dielectric strength, checking of viscosity of oil, terminal boxes (H T & L T both), insulators, Neutral Earthing, tightening of nuts bolts, cable sockets, stopping of leakages if any through joints	Year	If the transformer oil withstands insulation test upto 40 KV for one minute it is not necessary to dry and fill the transformer oil.
3.	Checking of its functioning	Year	
4.	Checking of condition of core of the transformer and its windings insulation condition.	5 years.	

(4)

SCHEDULE OF PREVENTIVE MAINTENANCE
Switchgears (Air or Oil Circuit Breakers)

Sl. No.	Name of Section or Part to be attended	Maintenance to be carried out	Frequency/time interval at which inspection & maintenance to be done	Remarks
1	Oil Circuit breaker or Air Circuit breaker	Checking, cleaning and tightening of nuts, bolts of fixed auxiliary contacts, moving auxiliary contacts, main fixed contacts, main moving contacts, No volt coil, overload coil, interlock system, condition of transformer oil, knife switches & insulators, etc.	Six months	
2.	Oil tank	Cleaning & topping of oil & Checking dielectric strength of transformer oil	Six months	
3.	Contacts	Changing of old & sluggish transformer oil of oil circuit breaker, Changing of old & wearing out contacts (fixed moving auxiliaries etc.)	Three years	Depending on the source of power supply & its tripping etc.

SCHEDULE OF PREVENTIVE MAINTENANCE
Sedimentation Tank with Clarifier and their drive

S. No.	Name of section or part to be attended	Maintenance to be carried out	Frequency/time interval at which inspection & maintenance to be done	Remarks
1.	Trolley wheels	Lubrication (greasing)	One month	
2.	Reduction Gear Box	Checking and topping of oil level	Three months	
3.	Turn Table mechanism	Checking and topping the oil level	Three months	
4.	Vertical slip Ring Motor	Dust blowing, checking of carbon brushes, bearings etc	Four months	
5.	Rail/Track	Adjustment of gap between two rails & its alignment etc	Four months	
6.	Reduction gear	Checking of helical spurgears condition	Six months	
7.	Rubber type wheels iron wheels	Checking of wear & tear alignment & its positioning	Six months	More frequently in the old installations
8.	M.S. Scrapers	Tightening of nuts & bolts, replacement of broken parts	Year	
9.	Turn table mechanism	Checking of its sprockets chains, steel balls, gear boxes etc.		

APPENDIX 24.1
MINIMUM LABORATORY EQUIPMENT NEEDED FOR TESTS

Equipment	Type of Plant	
	5 MLD	> 5 MLD
Analytical Balance	x	x
Autoclave		x
Centrifuge		x
Chlorine comparator	x	x
Colony counters		x
Demineralsiser	x	x
Dissolved Oxygen sampler	x	x
Drying oven (hot air)	x	x
Fume cupboards	x	x
Gas liquid chromatograph		x
Hot plates	x	x
Incubator 20° C (BOD)	x	x
Incubator 30° C (Bacteriological)		x
Kjehldahl Digester Unit	x	x
Magnetic stirrers	x	x
Microscope, binocular with oil immersion and movable stage counting cell		x
Membrane Filter Assembly		x
Mufflo Furnace	x	x
Orsat or equivalent gas analysis apparatus		x
pH comparator (Colorimetric)	x	x
pH meter with reference & spare electrodes		x
pH meter portable	x	x
Refrigerator	x	x
Sedwick Rafter funnel		x
Sludge sampler		x
Soxhlet extraction unit		x
Spectrophotometer (atomic absorption)		x
Spectrophotometer with or without U-V range or photo electric colorimeter		x
Total organic carbon analyser		x
Turbidimeter	x	x
Vacuum pump	x	x
Water bath (thermostat controlled)	x	x

Glassware and chemicals as required

APPENDIX 24.2

TESTS RECOMMENDED TO BE CARRIED OUT ON UNITS OF SEWAGE TREATMENT PLANTS

Treatment Stage/Unit	Total Suspended Solids	Settleable Solids	Dissolved Solids	Mixed Liquor Suspended Solids (MLSS)	SVI for ML	Turbidity	pH	Alkalinity	Volatile Acids	BOD	COD	DO	ORP	Total Kjeldahl Nitrogen
1	2	3	4	5	6	7	8	9	10	11	12	13	14	15
1. Raw Sewage	X	X	X				X	X		X	X			X
2. Primary Sedimentation tanks influent and effluent	X	X								X	X			
3. Trickling Filter influent & effluent	X						X			X	X	X		X
4. Activated sludge aeration tank influent & effluent										X	X	X	X	
5. Above tank contents				X	X									
6. Effluent of Secondary settling tank	X	X						X		X	X	X		X
7. Influent & effluent of septic tanks Imhoff tanks clarifiers	X	X	X							X	X			
8. Above tank contents							X	X	X					
9. Digester contents							X	X	X					
10. Primary sludge														
11. Secondary settled sludge														
12. Digested sludge							X	X	X					
13. Sludge digester supernatant	X		X				X	X		X	X			X
14. Stabilisation ponds influent & effluent	X					X				X	X	X		
15. Above pond contents							X	X				X	X	

APPENDIX 24.2 (Contd...)

TESTS RECOMMENDED TO BE CARRIED OUT ON UNITS OF SEWAGE TREATMENT PLANTS

Treatment Stage / Unit	Ammoniacal Nitrogen	Nitrate	Phosphates	Heavy Metals	Toxic Substances	Total Solids (%)	Volatile Solids (%)	NPK Ratio	Colour and Texture	Specific Gravity	Colour and Texture of sludge	Microscopic Examination for flora & fauna	Microbial Growth Rate	Oxygen Uptake Rate	Algal Cell Concentration	Others as Specified
1	16	17	18	19	20	21	22	23	24	25	26	27	28	29	30	31
1. Raw Sewage	X	X	X	X	X											Bio-Assay Tests
2. Primary Sedimentation Tanks influent and effluent																
3. Trickling Filter influent & effluent	X	X														MDH of coliforms for treated effluent
4. Activated sludge aeration tank influent & effluent																any
5. Above tank contents												X	X	X		
6. Effluent of Secondary settling tank		X														
7. Influent & effluent of septic tanks Imhoff tanks clarifiers																
8. Above tank contents						X	X									
9. Digester contents																
10. Primary sludge						X	X			X						
11. Secondary settled sludge						X	X			X						
12. Digested sludge						X	X	X	X	X						
13. Sludge digester supernatant																
14. Stabilisation ponds influent & effluent																
15. Above pond contents									X						X	
OTHER TESTS	1. Sludge from Septic Tanks Imhoff Tanks etc					Microscopic examination for Ova, Cysts, Pathogens										
	2. Digester Gas					Complete Gas Analysis										
	3. Chlorinated Effluent					Chlorine residual										

APPENDIX 25.1

DESIGN EXAMPLE FOR VENTURIMETER

Problem : Design of Venturi Meter using the following data :

1. A venturimeter will be provided in the force main. The force main is 92 cm (36 in.) in diameter.
2. The tube beta ratio (diameter of throat/diameter of the force main) shall be equal to 0.5
3. Maximum and minimum flow ranges are 1.321 and 0.152 m³/s. respectively.
4. The flow measurement error shall be less than ± 0.75 percent at all flows.
5. The head loss shall not exceed 15 percent of the meter readings at all flows.
6. The selected venturimeter shall be capable of measuring flows of solids bearing liquids.

Solution :

$$Q = \frac{A_1 A_2 \sqrt{2gh}}{\sqrt{A_1^2 - A_2^2}} \quad (1)$$

Where: Q = pipe flow m³/s.
 H₁ = upstream peizometric head, m
 H₂ = throat peizometric head, m
 A₁ = force main area, m²
 A₂ = throat area, m²
 h = H₁ - H₂, m

Under actual operating conditions and for standard meter tubes, including allowance for friction, the above equation reduces to

$$Q = C_1 K A_2 \sqrt{2gh} \quad (2)$$

Where

C_1 = Velocity, friction or discharge coefficient (dimensionless)

K = Coefficient (dimensionless)

$$= \frac{1}{\sqrt{1 - \left(\frac{A_2}{A_1}\right)^2}} \quad (3)$$

$$= \frac{1}{\sqrt{1 - \left(\frac{D_2}{D_1}\right)^4}} \quad (4)$$

D_1 , D_2 diameter of pipe and throat, m. For Standard Venturi meter the diameter of the throat is one third to one half of the pipe diameter and the value of k lies between 1.0002 and 1.0328. The value of C_1 generally ranges from 0.97 to 0.99.

The value of C_1 is normally provided by the manufacturer.

Unit Sizing and Calibration Curve :

1. Determine constants.
The venturimeter tube has $D_2/D_1 = 0.5$
Throat diameter $D_2 = 46$ cm.

$$\therefore K = \frac{1}{\sqrt{1 - 0.5^4}} = 1.0328$$

2. Develop calibration equation from equation 2
Assume $C_1 = 0.985$

$$Q = 0.985 \times 1.0328 \times \frac{\pi}{4} \times 0.146^2 \sqrt{2 \times 9.81 \times \frac{m}{s^2} \times \sqrt{h}}$$

$$= 0.7489 \sqrt{h} \text{ m}^3/\text{s}.$$

3. Develop calibration curve :

Assigning different values of differential head recorded by the meter, the pipe discharge can be obtained from equation. At maximum peak design and minimum initial flows of 1.321 and 0.152 Cu.M/s the differential meter readings will be 3.111 and 0.041 m respectively (122.48 and 1.61 in.). The calibration curve is shown in figure. If mercury is used in the glass tube, then the differential pressure readings must be adjusted for the specific weight of mercury (13.58).

Head loss Calculations :

In a venturimeter tube, due to gradual contraction of the approach section, the head loss is considered negligible. Likewise, due to short length of the throat, the head loss in this section can be neglected. The head loss in the recovery section is estimated from:

$$h_L = \frac{KV_2^2}{2g}$$

Where h_L = head loss through the venturimeter, m
 K = 0.14 for angles of divergence of 5°

At maximum and minimum flows of 1.321 and 0.152 m³/s, the head losses are calculated as follows

$$h_L \text{ at maximum flow} = \frac{0.14}{2 \times 9.81} \left[\frac{1.321}{\frac{\pi}{4} \times (0.46)^2} \right]^2 = 0.45 \text{ m}$$

APPENDIX. 25.1

$$h_l \text{ at minimum flow} = \frac{0.14}{2 \times 9.81} \left[\frac{0.152}{\frac{\pi}{4} \times (0.46)^2} \right]^2 = 0.006m$$

These head loss values are 14.8 percent of the differential readings of the meter at respective flows.

Head loss when the flow is 50 mld. or 0.578 m³/s.

$$= \frac{0.14}{2 \times 9.81} \left[\frac{0.578}{\frac{\pi}{4} \times (0.46)^2} \right]^2 = 0.086m$$

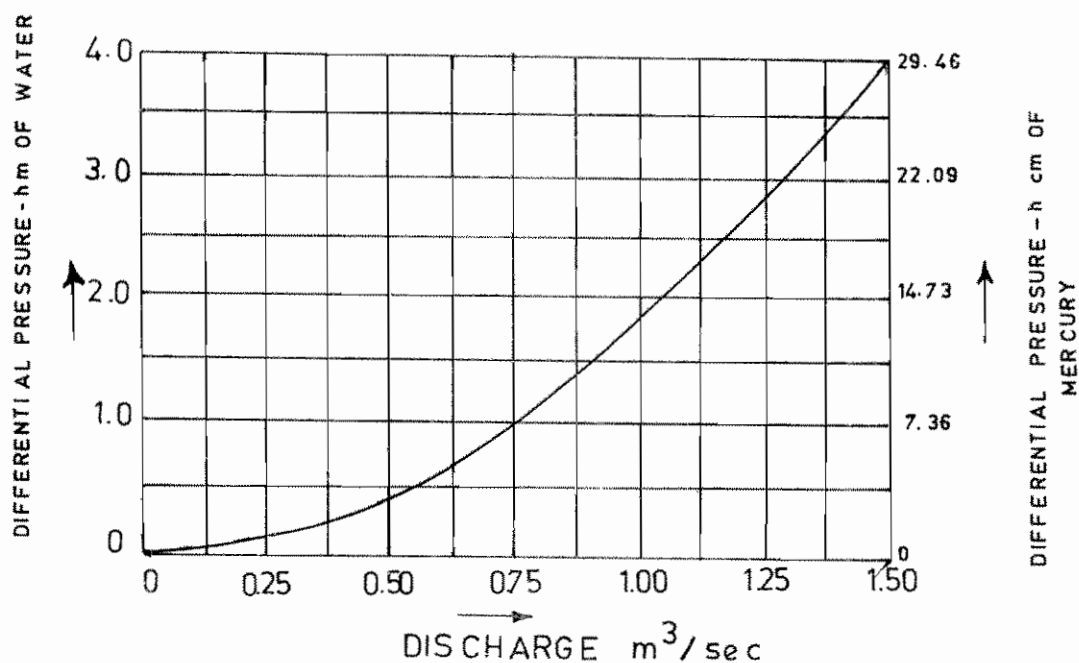

CALIBRATION CURVE OF THE
VENTURI - TUBE METER

APPENDIX 27

BIBLIOGRAPHY

1. "Water and Wastewater Engineering" Vol I - "Water Supply and Wastewater Removal", Vol II - "Water Purification and Wastewater Treatment and Disposal". Fair, G.M., Geyer, J.C. and Okun, D.A., 1981, Wiley & Toppan.
2. "Wastewater Engineering : Treatment, Disposal and Use" Second Edition 1979, Metcalf and Eddy, Inc. Revised by G.Tchobanoglous, Tata Mc.Graw - Hill, New Delhi.
3. "Environmental Engineering" 1986, Peavy, H.S., Rowe.D.R., and Tchobanoglous G., Mc.Graw - Hill Book Company.
4. "Wastewater Treatment Plants - Planning, Design and Operation", 1985, Qasim, S.R., Holt, Rinehart and Winston.
5. "Wastewater Treatment for Pollution Control", 1986, Arceivala, S.J., Tata Mc-Graw Hill Publishing company.
6. "Water Treatment Handbook" 5th Edition, 1979, Degremont, John Wiley & Sons.
7. "Sewerage and Sewage Treatment" First Indian Edition 1960, Babbitt, H.E. and Baumann, E.R.
8. "Public Health Engineering Practice" Fourth Edition 1972, Vol II-Sewerage and Sewage Disposal, Escritt.L.B.
9. "Public Health Engineering - Design in Metric" 1970. Sewerage, Bartlett R.E.
10. "Design and Construction of Sanitary and Storm Sewers", Revised Edition 1970, Manual of Practice No.9, Water Pollution Control Federation, Washington, D.C. U.S.A.
11. "Sewage Treatment Plant design" 1959, Manual of Practice No.8, Water Pollution Control Federation, Washington, D.C. U.S.A.
12. "Disposal of Sewage and other Water-Borne Wastes", Second Edition 1971, Imhoff K.M., Muller W.J. and Thistlewayte D.K.B.
13. "Wastewater Systems Engineering" 1975, Parker H.W.
14. "Advanced Wastewater Treatment" 1971, Culp R.L. and Culp G.L.
15. "Sewage Treatment-Basic Principles and Trends", Second Edition 1972, Bolton R.L. and Klein L.
16. "The Disposal of Sewage", Third Editin 1956, Veal T.H.P.

17. "Sewerage and Sewage Treatment" Third Edition 1956, Hardenbergh W.A.
18. "Unit Operations of Sanitary Engineering" 1961, Rich L.G.
19. "Environmental Engineering and Sanitation", Second Edition 1971, Salvato J.A. Jr.
20. "The Design and Operation of Small Sewage Works" 1976, Barnes D. and Wilson F.
21. "Environmental Engineering Handbook" 1974, Vol.I-Water Pollution, Liptak B.G.
22. "Hand Book of Applied Hydraulics" Third Edition 1969, Davies C.V. and Sorensen K.E.
23. "Open Channel Hydraulics" 1959, Ven Te Chow.
24. "Biological Treatment of Sewage and Industrial Wastes" 1957, McCabe J and Eckenfelder W.W.
25. "Practical House Drainage" Revised Edition 1971. Southhall C.S and Prentice H.O.
26. "Chemistry for Sanitary Engineers" 1967, Sawyer C.N. and McCarty P.L.
27. "Microbiology for Sanitary Engineers" 1962, McKinney R.E.
28. "Waste Stabilisation Ponds" 1970, Design, Construction and Operation in India, Central Public Health Engineering Research Institute, Nagpur.
29. "Methods for the Examination of Water, Sewage and Industrial Wastes" 1963, Indian Council of Medical Research.
30. "Sewage Treatment for Small Communities - Developments" 1977, Indian Association for Water Pollution Control. Technical Annual No.4 (convention number), V. Raman.
31. "Upflow Anaerobic Filter - A Simple Sewage Treatment Device" 1978., International Conference on Water Pollution Control for Developing Countries, Bangkok, V. Raman and A.N. Khan.
32. "Process Design Manual for Upgrading Existing Wastewater Treatment Plants" 1974, Technology Transfer, U.S. Environmental Protection Agency.
33. Technical Grade lines on "Twin Pit Pour Flush Latrines" prepared by Ministry of Urban Development and Regional Water and Sanitation Group, South Asia UNDP/World Bank, Water and Sanitation Progress - April - 1992.

APPENDIX 28

Geometric Elements For Circular Channel Sections

y	a	p	r	$ar^{2/3}$	y	a	p	r	$ar^{2/3}$
d_0	d_0^2	d_0	d_0	$d_0^{5/3}$	d_0	d_0^2	d_0	d_0	$d_0^{5/3}$
0.01	0.0013	0.2003	0.0066	0.0000	0.53	0.4227	1.6300	0.2591	0.1715
0.02	0.0037	0.2838	0.0132	0.0002	0.54	0.4327	1.6509	0.2620	0.1772
0.03	0.0069	0.3482	0.0197	0.0005	0.55	0.4426	1.6710	0.2649	0.1825
0.04	0.0105	0.4027	0.0262	0.0009	0.56	0.4526	1.6911	0.2676	0.1878
0.05	0.0147	0.4510	0.0326	0.0015	0.57	0.4625	1.7113	0.2703	0.1933
0.06	0.0192	0.4949	0.0389	0.0022	0.58	0.4723	1.7315	0.2728	0.1987
0.07	0.0242	0.5355	0.0451	0.0031	0.59	0.4822	1.7518	0.2753	0.2041
0.08	0.0294	0.5735	0.0513	0.0040	0.60	0.4920	1.7722	0.2776	0.2092
0.09	0.0350	0.6094	0.0574	0.0052	0.61	0.5018	1.7926	0.2797	0.2146
0.10	0.0409	0.6435	0.0635	0.0065	0.62	0.5115	1.8132	0.2818	0.2199
0.11	0.0470	0.6761	0.0695	0.0079	0.63	0.5212	1.8338	0.2839	0.2252
0.12	0.0534	0.7075	0.0754	0.0095	0.64	0.5308	1.8546	0.2860	0.2302
0.13	0.0600	0.7377	0.0813	0.0113	0.65	0.5404	1.8755	0.2881	0.2358
0.14	0.0668	0.7670	0.0871	0.0131	0.66	0.5499	1.8965	0.2899	0.2407
0.15	0.0739	0.7954	0.0929	0.0152	0.67	0.5594	1.9177	0.2917	0.2460
0.16	0.0811	0.8230	0.0986	0.0173	0.68	0.5687	1.9391	0.2935	0.2510
0.17	0.0885	0.8500	0.1042	0.0196	0.69	0.5780	1.9606	0.2950	0.2560
0.18	0.0961	0.8763	0.1097	0.0220	0.70	0.5872	1.9823	0.2962	0.2608
0.19	0.1039	0.9020	0.1152	0.0247	0.71	0.5964	2.0042	0.2973	0.2653
0.20	0.1118	0.9273	0.1206	0.0273	0.72	0.6054	2.0264	0.2984	0.2702
0.21	0.1199	0.9521	0.1259	0.0301	0.73	0.6143	2.0488	0.2995	0.2751
0.22	0.1281	0.9764	0.1312	0.0333	0.74	0.6231	2.0714	0.3006	0.2794
0.23	0.1365	1.0003	0.1364	0.0359	0.75	0.6318	2.0944	0.3017	0.2840
0.24	0.1449	1.0239	0.1416	0.0394	0.76	0.6404	2.1176	0.3025	0.2888
0.25	0.1535	1.0472	0.1466	0.0427	0.77	0.6489	2.1412	0.3032	0.2930
0.26	0.1623	1.0701	0.1516	0.0464	0.78	0.6573	2.1652	0.3037	0.2969
0.27	0.1711	1.0928	0.1566	0.0497	0.79	0.6655	2.1895	0.3040	0.3008
0.28	0.1800	1.1152	0.1614	0.0536	0.80	0.6736	2.2143	0.3042	0.3045
0.29	0.1890	1.1373	0.1662	0.0571	0.81	0.6815	2.2395	0.3044	0.3082
0.30	0.1982	1.1593	0.1709	0.0610	0.82	0.6893	2.2653	0.3043	0.3118
0.31	0.2074	1.1810	0.1755	0.0650	0.83	0.6969	2.2916	0.3041	0.3151
0.32	0.2167	1.2025	0.1801	0.0690	0.84	0.7043	2.3186	0.3038	0.3182
0.33	0.2260	1.2239	0.1848	0.0736	0.85	0.7115	2.3462	0.3033	0.3212
0.34	0.2355	1.2451	0.1891	0.0776	0.86	0.7186	2.3746	0.3026	0.3240
0.35	0.2450	1.2661	0.1935	0.0820	0.87	0.7254	2.4038	0.3017	0.3264
0.36	0.2546	1.2870	0.1978	0.0864	0.88	0.7320	2.4341	0.3008	0.3286
0.37	0.2642	1.3078	0.2020	0.0909	0.89	0.7380	2.4655	0.2996	0.3307
0.38	0.2739	1.3284	0.2061	0.0955	0.90	0.7445	2.4981	0.2980	0.3324
0.39	0.2836	1.3490	0.2102	0.1020	0.91	0.7504	2.5322	0.2963	0.3336
0.40	0.2934	1.3694	0.2142	0.1050	0.92	0.7560	2.5681	0.2944	0.3345
0.41	0.3032	1.3898	0.2181	0.1100	0.93	0.7612	2.6061	0.2922	0.3350
0.42	0.3132	1.4101	0.2220	0.1147	0.94	0.7662	2.6467	0.2896	0.3353
0.43	0.3229	1.4303	0.2257	0.1196	0.95	0.7707	2.6906	0.2864	0.3349
0.44	0.3328	1.4505	0.2294	0.1245	0.96	0.7749	2.7389	0.2830	0.3340
0.45	0.3428	1.4706	0.2331	0.1298	0.97	0.7785	2.7934	0.2787	0.3322
0.46	0.3527	1.4907	0.2366	0.1348	0.98	0.7816	2.8578	0.2735	0.3291
0.47	0.3627	1.5108	0.2400	0.1401	0.99	0.7841	2.9412	0.2665	0.3248
0.48	0.3727	1.5308	0.2434	0.1452	1.00	0.7854	3.1416	0.2500	0.3117
0.49	0.3827	1.5508	0.2467	0.1505					
0.50	0.3927	1.5708	0.2500	0.1558					
0.51	0.4027	1.5908	0.2531	0.1610					
0.52	0.4127	1.6108	0.2561	0.1664					

d_0 = diameter
 y = depth of flow
 a = water area
 p = wetted perimeter
 r = Hydraulic radius.

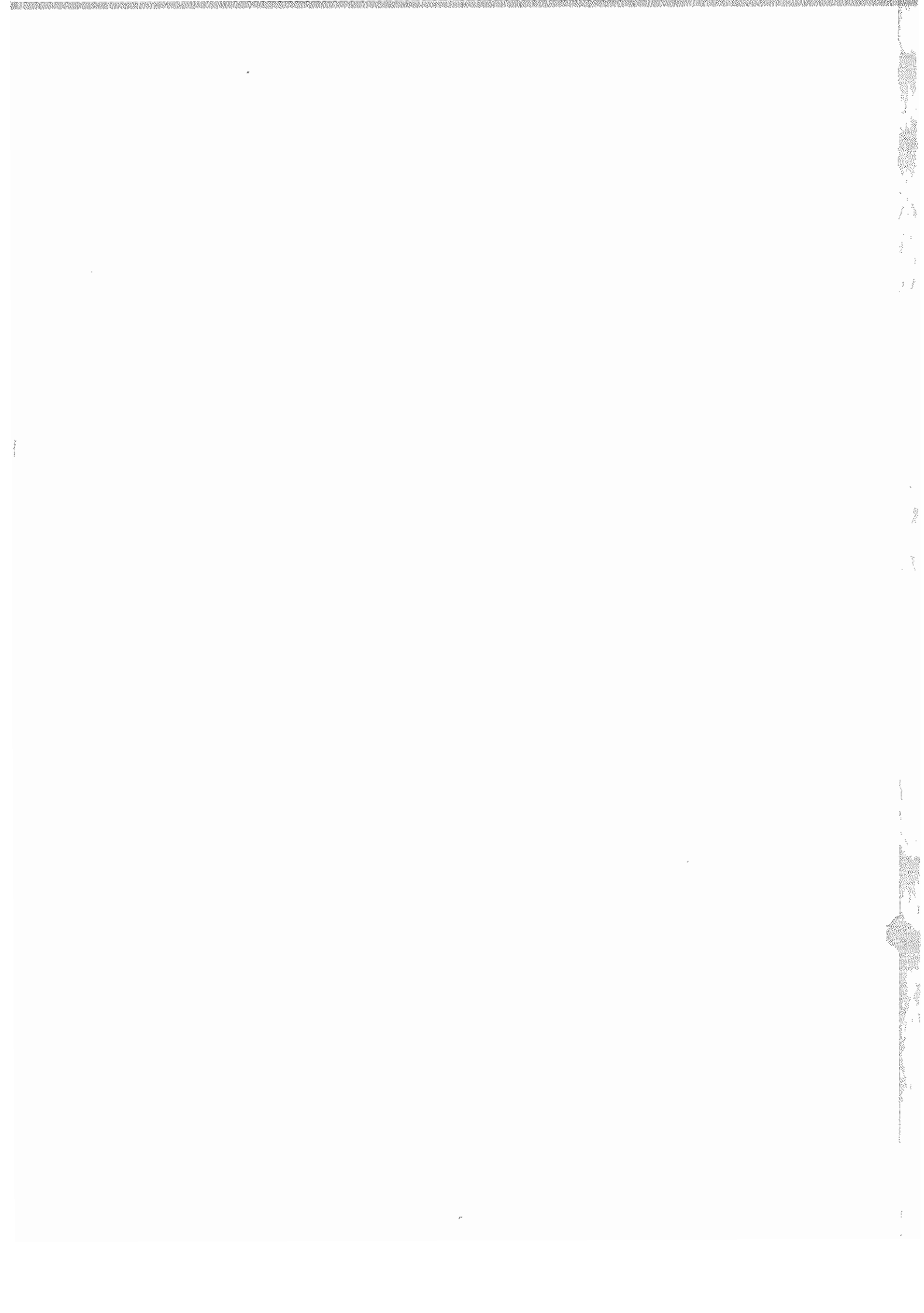

ERRATA

S.No	Page	Article	Para	Line	Instead	Read As
1	8	1.6.2	1	3	3.1	Chapter 3
2	11	1.8.2.3-b	2	2	7.3.1	7.1.3
3	41	3.3.1.3	1	1	intensity duration	intensity and duration
4	46	3.4.2.1	-	3	$V = \frac{1}{n} (3.968 \times 10^{-3}) D^{2/3} S^{1/2}$	$V = \frac{1}{n} (3.968 \times 10^{-3}) D^{2/3} S^{1/2}$
5	49	3.4.2.5	Below Table 3.5	1	These pipe	* These pipe
6	61		--	1	the pipe	the first pipe
7	61		--	4	411	4111
8	66	3.5.4.1	1	4	intercepted high	intercepted, high
9	77	4.2.1.2	3	5	atleast	at least
10	95	6.3.2.1 (a)(i)	3	3	ratios	ratio
11	126	7.1.1.3	1	1	of	or
12	127	7.1.2	1	4	activity zones	activity zones,
13	128	7.1.2.2(b)	2	3	leads	loads
14	129	7.1.3.1	1	2	hunching	haunching
15	155	9.5.2.1	1	3	dru	dry
16	157	--	1	2	will	well
17	165	9.7.5.5	1	2,13	nett	net
18	165	--	--	20	Nett	Net
19	169	9.7.8	6	4	drawn	draw
20	170	9.7.9.4	1	1	consumable	consumables
21	175	9.7.10.2	j	4	accel	acceleration
22	176	9.7.10.3	c	3	pumps	pump
23	178	9.8.8	1	3	complied	compiled
24	180	9.9.4	Table 9.5	Row 2/line 3, Col.4	--	IS 7098
25	181	9.11.1	1	1	consumable	consumables
26	188	10.5.4	1	2	putrescoble	putrescible
27	189	10.6	2	1	waste	wastes

ERRATA

S.No	Page	Article	Para	Line	Instead	Read As
28	191		Table 10.1	Row 4(a). Col.1	Grwoth	Growth
29	191		Table 10.1	Row 4(a) & 4(b) col.1	Biological	Biological
30	191		Table 10.1	Sl.5 col.2	'organic'	--
31	192	10.9.3	Equation 10.1	description of K	'that'	--
32	193		3	4.5 & 9	(θ_c)	θ_c
33	193		3	7	(θ)	θ
34	194	--	Table 10.2	Column 2 (heading)	concentration	concentration.S
35	194	--	Table 10.2	Row 1, col.3	$\frac{Y(S_0 - S)}{1 + K_d \theta}$	$\frac{Y(S_0 - S)}{1 + K_d \theta}$
36	199	10.10	Table 10.3	3(ii)b col.4	90-60	90-96
37	199	10.10	Table 10.3	3(iii)col.2	85-90	85-95
38	200	11.1.1	3	8	areas	area
39	203	11.2.1	1	8	nonputrescible	nonputrescible
40	206	--	--	2	10 degree	10 degrees C
41	208	11.2.5.2	4	1	velocition	velocities
42	209		--	1	particle	particles
43	226	13.3	1	3	nave	have
44	237	Table 13.2 (Titles)	--	Column.5	comparsion	comparision
45	246	14.2.3.2	Eq.14.2		BOD loadind	BOD loading
46	251	Table 14.2	Heading	--	RECENT	PERCENT
47	254	14.3.1	3	4	suitable	suitably
48	259	15.3.2	Eq.15.3	--	$\frac{L_e}{L_i} \frac{1}{1 + K_d t}$	$\frac{L_e}{L_i} \frac{1}{1 + K_d t}$
49	259	15.3.2	4	2	0.2	0.3
50	266	16.2.3	heading	--	Fixed Films	Fixed film
51	266	16.2.3	1	4	for	or
52	270	17.1	1	2	setttable	settleable
53	270	17.1	2	4	aid	aim
54	270	17.1	2	6	removed	removal

ERRATA

S.No	Page	Article	Para	Line	Instead	Read As
55	270	17.2.1	1	2	activate	activated
56	271	17.2.2	heading	--	floatation	flotation
57	271	17.2.2	1	1	floatation	flotation
58	271	17.2.2	2	1	floatation	flotation
59	273		2	3	drving	drying
60	285	17.4.1.5	Eq(17.4)		$-V_d T_2$	$+V_d T_2$
61	296	Chapter 18.1	1	1	differenent	different
62	298	18.3.3	2	3	startor	starter
63	300	18.7.3	1	4	sould	should
64	301		2	2	ot	to
65	305		Table 19.2	Column.9 heading	Colifomrs	Coliforms
66	307	19.5.1	Table 19.3	S.No.12	Langeller	Langliar
67	308		2	3	(F)	A to F
68	320	20.4	1	2	cultrue	culture
69	328	20.8.1.3	1	1	ussually	usually
70	334		Table 21.2	Note.3 Line 2	ofmaintenance	for maintenance
71	337	21.2.4	4	2	Appendex 22.1	Appendix 21.1
72	338	21.2.4.3	1	3	nad	and
73	338	21.2.4.3	1	7	oder	odour
74	342		Table 21.5	S.No.3 Line 2	silty Silty	Silty
75	342		Table 21.5	S.No.4 Line 2	silty clay	clay
76	349	21.3.2.3	2	4	and	or
77	350	21.3.3.1	1	2	2M	2m
78	350	21.3.3.3	1	5	imperivous	impervious
79	351	21.4.1	2	2	eleminated	eliminated
80	352	21.4.5	1	10	foating	floating
81	352	21.4.6	2	1	odor	odour
82	352	21.4.6	2	2	minimum vent pipe	vent pipe
83	363	22.3.1	1	3	necessaray	necessary

ERRATA

S.No	Page	Article	Para	Line	Instead	Read As
84	364	22.3.4	1	2	areation	aeration
85	365	22.3.8	1	2	chemicl	chemical
86	365	Table 22.2	Col.2			--
87	366	22.3.9	1	3	protectiv	protective
88	368	23.2.1	2	2	throughly	thoroughly
89	369	23.2.3.2	1	3	chracteristics	characteristics
90	370	23.2.4	1	3	through	thorough
91	371		1	1	stabilisation	stabilisation
92	371		1	4	throughly	thoroughly
93	371	23.2.4.5	1	1	contain	contains
94	372		1	5	interfers	interferes
95	372	23.2.5.1	4	1	operting	operating
96	374		5	1	lubricted	lubricated
97	376		6	4	voltile	volatile
98	377	23.3.2	6	2	operted	operated
99	377	23.3.2	8	1	manually	automatically
100	378		1	6	wherever necessary	(wherever necessary)
101	378		3	4	extenguishing	extinguishing
102	383	24.2.1.11	1	3	fumr	fume
103	383	24.2.1.15	1	2	andled	handled
104	383	24.2.1.15	1	3	efrigerators	refrigerators
105	383	24.2.1.16	1	4	eary	easy
106	385	24.3.1.1	1	1	concentratons	concentrations
107	386		1	2	detches	detaches
108	386	24.4.4	11	3	mircorbial	microbial
109	388	24.5.3	1	1	precausions	precautions
110	424		--	10	vesses	vessels
111	430		--	8	Verted	Inverted
112	458				i.e $\Delta / =$	$\Delta L =$
113	487		--	1	$\frac{73 \times 25}{1000} \times \frac{1}{1000}$	$\frac{73 \times 25}{1000}$

ERRATA

S.No	Page	Article	Para	Line	Instead	Read As
114	490		--		$Z_3 + d_3 = \frac{V_3^2}{2g} = Z_4$	$Z_3 + d_3 + \frac{V_3^2}{2g} = Z_4$
115	493			17	Assuming $\eta = 75\%$	Assuming $\eta = 0.75$
116	506		--	3	10299m	102.99m
117	509		--	check for hydraulic loading	50.00x10x1(1x1)	50.00x10x1(1+1)
118	513		--	Average discharge per lateral	$\frac{q}{d_o^2}$	$\frac{a}{d_o^2}$
119	513		under drainage system	9	q	none
120	513	--	--		From Appendix 26	From Appendix 28
121	514		--	1	3	1.736 3
122	514				From Appendix 26	From Appendix 28
123	518		--	design of Exit channel	$r = (A/P)$ or $[r/(w+2d)] =$	$r = (A/P)$ or $r = [(wxd)/(w+2d)]$
124	520	Appendix 14.2	2	3	discs	disc
125	521	Appendix 15.1	pond size	para 2 line1	235/(1+0.003x100)	235/(1+0.003x1)
126	521	Appendix 15.1	pond size	para 2 line2	180 kg BOD/ha.d	234 Kg BOD/ha.d
127	543	Appendix 24.1	--	8th Row	Drying over	Drying oven
128	543	Appendix 24.1	--	18th Row	Mufflo Furnace	Muffle Furnace
129	543	Appendix 24.1	--	24th Row	funner	funnel



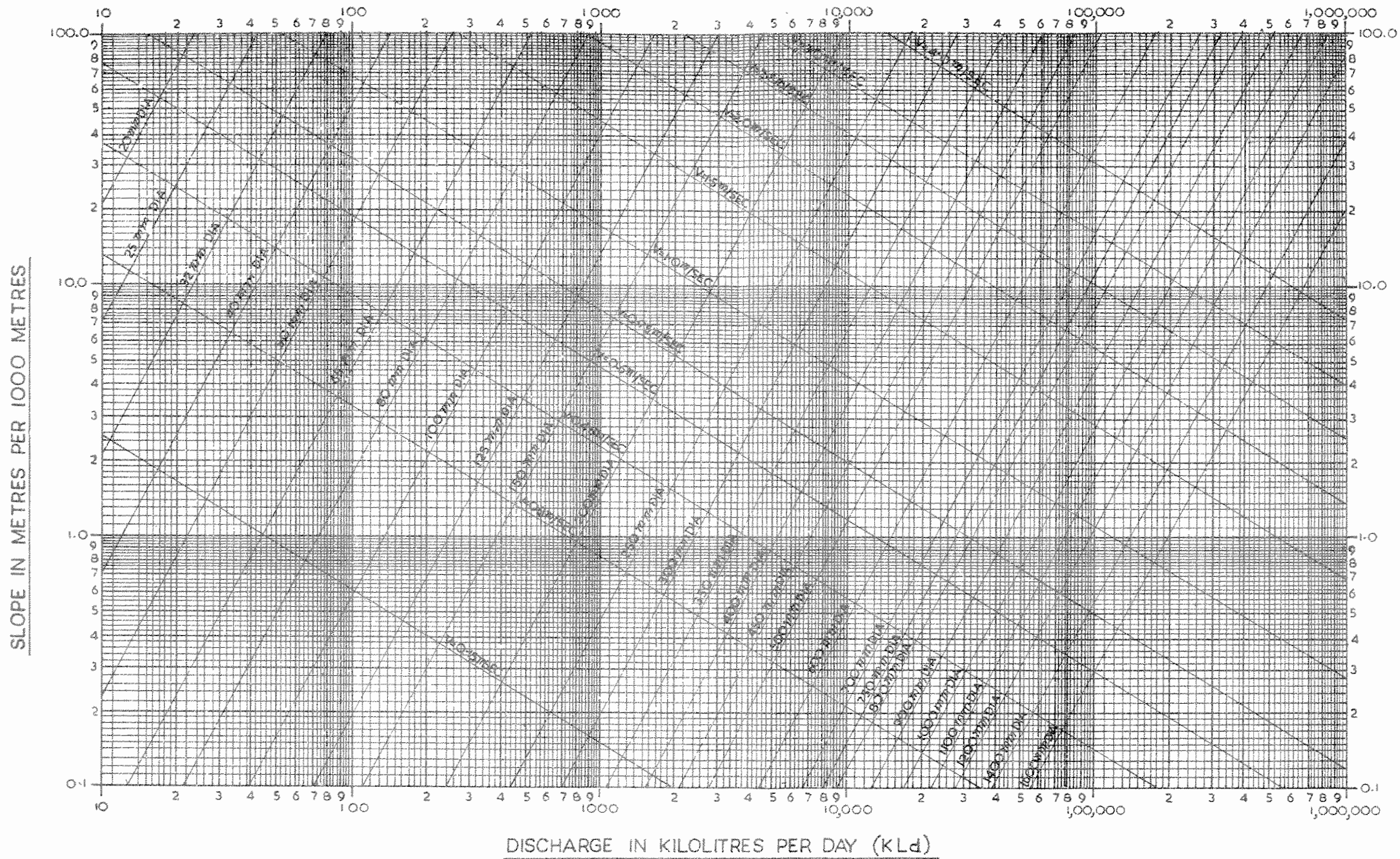

NOTE :-

FOR ANY OTHER VALUE OF 'C' SAY 'C₁' THE VALUES OF *v* AND Q AS FOUND FOR A GIVEN *d* AND *s* FROM THE CHART ARE TO BE MULTIPLIED BY A FACTOR $K = \left(\frac{C_1}{100}\right)$ AND FOR A GIVEN *d* AND Q OR *v*, THE VALUE OF SLOPE AS FOUND FROM THE CHART HAS TO BE MULTIPLIED BY A FACTOR $K_2 = \left(\frac{100}{C_1}\right)^{1.85}$

VALUE OF C	70	80	90	100	110	120	130	140
K ₁	0.7	0.8	0.9	1.0	1.1	1.2	1.3	1.4
K ₂	1.94	1.51	1.22	1.0	0.84	0.71	0.62	0.54

CHART FOR DISCHARGE ETC. ACCORDING TO HAZEN & WILLIAMS FORMULA

$$\begin{aligned}
 1 \quad v &= 4.567 \times 10^3 \times C^x \times d^{0.63} \times s^{0.54} \\
 2 \quad Q &= 3.1 \times 10^3 \times C^x \times d^{2.63} \times s^{0.54} \\
 3 \quad v &= 0.849 \times C^x \times s^{0.63} \times d^{0.54}
 \end{aligned}$$

WHERE

- v* = VELOCITY IN METRES PER SECOND
- Q = DISCHARGE IN KILOLITRES PER DAY (KLD)
- d* = DIA OF CIRCULAR PIPE IN mm
- s* = SLOPE
- C = HAZEN AND WILLIAMS COEFFICIENT OF 100 ADOPTED
- r* = HYDRAULIC RADIUS IN METRES

