

**RELIANCE INDUSTRIES LTD.
(VADODARA MFG. DIV.)**

**NATIONAL AWARD FOR EXCELLENCE
IN WATER MANAGEMENT – 2007
(Within The Fence)**

ORGANISED

BY CII

PRESENTATION

BY

ANIL KEWALRAMANI (GM – CTS- ENERGY & UTILITIES)

SANJAY J. PATEL (SM – HSE - ENVIRONMENT)

MUMUKSHA VYAS (MGR – CTS - ENVIRONMENT)

Overview

- ✓ **Introduction of RIL, Vadodara Mfg. Div. (VMD)**
- ✓ **Environment Policy**
- ✓ **Organogram**
- ✓ **Sp. Water Consumption Trend**
- ✓ **Sp. Waste Water Discharge Trend**
- ✓ **Major WaterCon Measures of 2006-07 , 2005-06 & 2004-05**
- ✓ **Major WaterCon Awareness Initiatives**
- ✓ **Major Environment improvement measures**
- ✓ **Monitoring Reports**
- ✓ **Benchmarking**
- ✓ **Achievements**
- ✓ **Forward Path**



Water conservation Message

For Future, Business & Industry needs to put in place certain adaptation measures such as preparing for high levels of water scarcity & stress through measures such as recycling water & using every drop of water more efficiently

Shri R.K.Pachauri (TERI & IPCC)

History of Reliance Industries Limited (VMD)



- ✓ **Established as IPCL, Govt. of India undertaking at Baroda in 1969. Baroda complex commissioned in 1973**
- ✓ **Nagothane complex commissioned in 1991**
- ✓ **Gandhar complex commissioned in 1996**
- ✓ **Disinvestment in June 2002 with Mgmt. Control by Reliance group companies.**
- ✓ **Merger of six RIL fiber companies in 2005.**
- ✓ **Merging of IPCL with RIL w.e.f. 5th Sept. 2007.**





Environment Policy

Protection of environment is of prime concern and an important business objective at Reliance. With a leading role in providing competitive goods and services in the materials and energy value chains and infrastructure in India, Reliance is conscious of its responsibility towards creating, maintaining and ensuring a safe and clean environment for sustainable development.

In particular, Reliance is committed to:

- Comply with relevant laws and regulations as well as take any additional measures considered necessary.
- Follow a systematic approach to environmental management plan in order to achieve continual performance improvement.
- Prevent pollution, maximize recycle, reduce wastes, discharges and emissions.
- Conserve natural resources by their responsible and efficient use in all our operations.
- Plant trees, develop green belts and promote lush green surroundings at our manufacturing locations to be in harmony with nature.
- Emphasize every employee's responsibility in environmental performance, ensure appropriate operating practices and training.
- Promote awareness among contractors, suppliers and customers for shared responsibility towards environment protection.
- Make this policy available to the public.

Mukesh D. Ambani

2005

Organizational Structure (w.r.t Water Management)

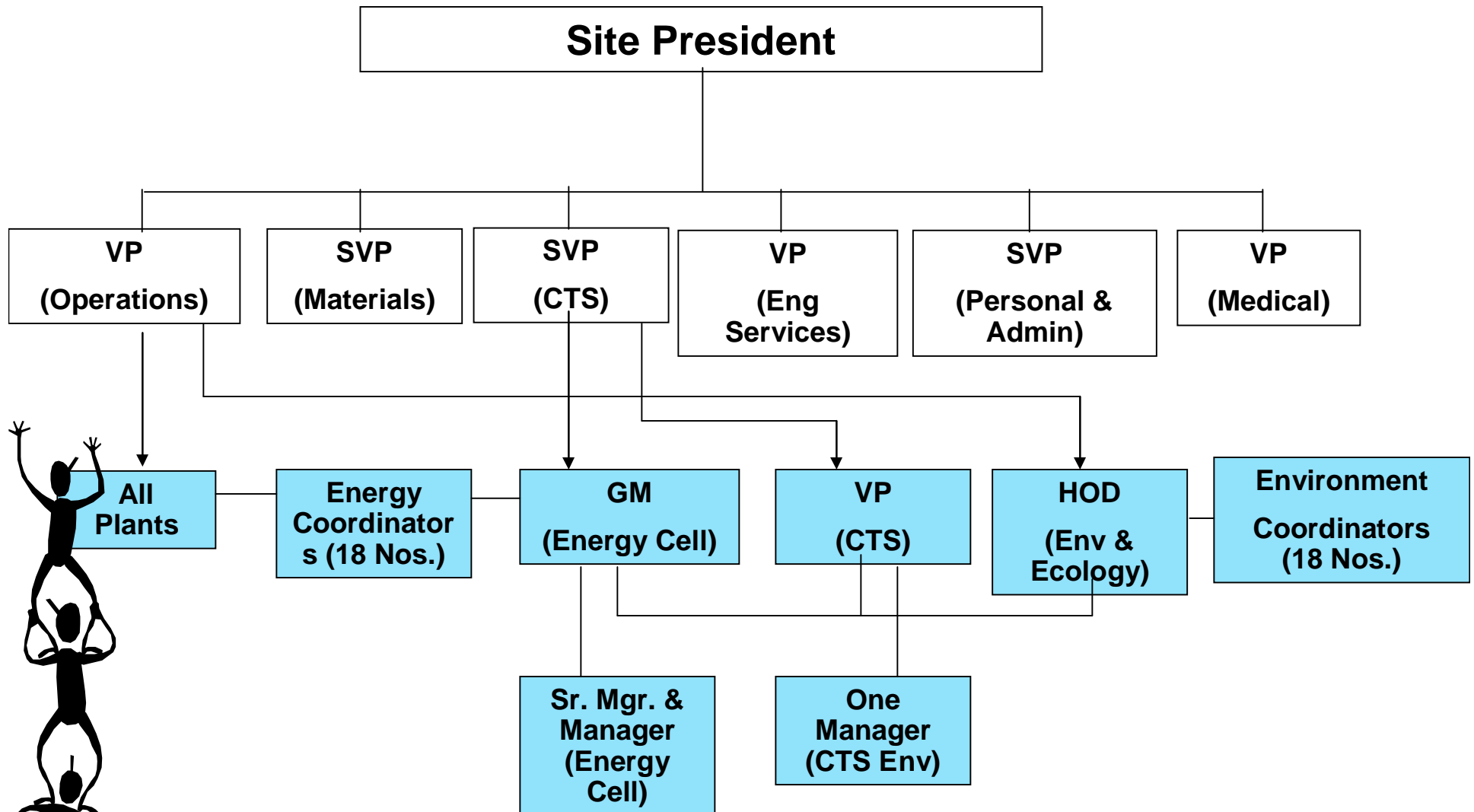

SPECIFIC WATER CONSUMPTION (M3/MT)



Water consumption

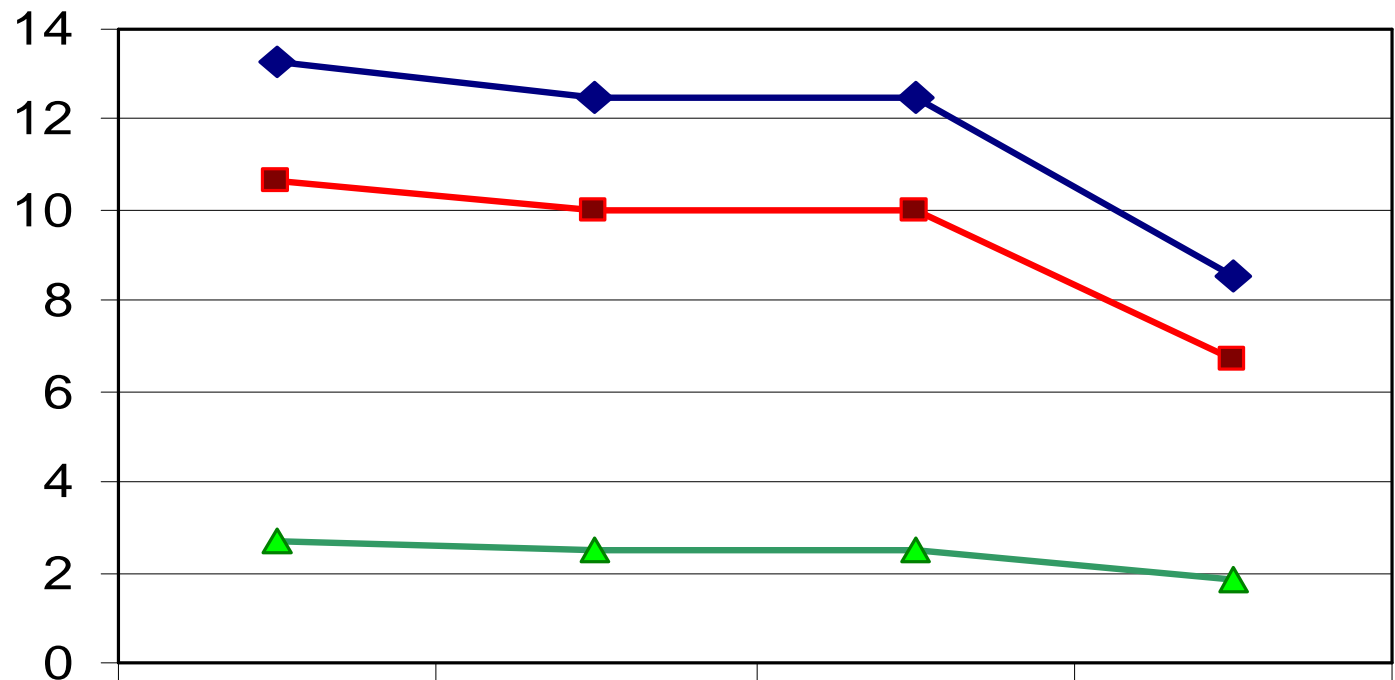

◆ Spec. total water consum.

■ Spec. Industrial water consum.

▲ Spec. Domestic water consum.

03-04

04-05

05-06

06-07

13.293

12.495

12.480

8.575

10.616

9.996

9.984

6.728

2.677

2.499

2.496

1.848

SPECIFIC WASTEWATER DISCHARGE (M3/MT)

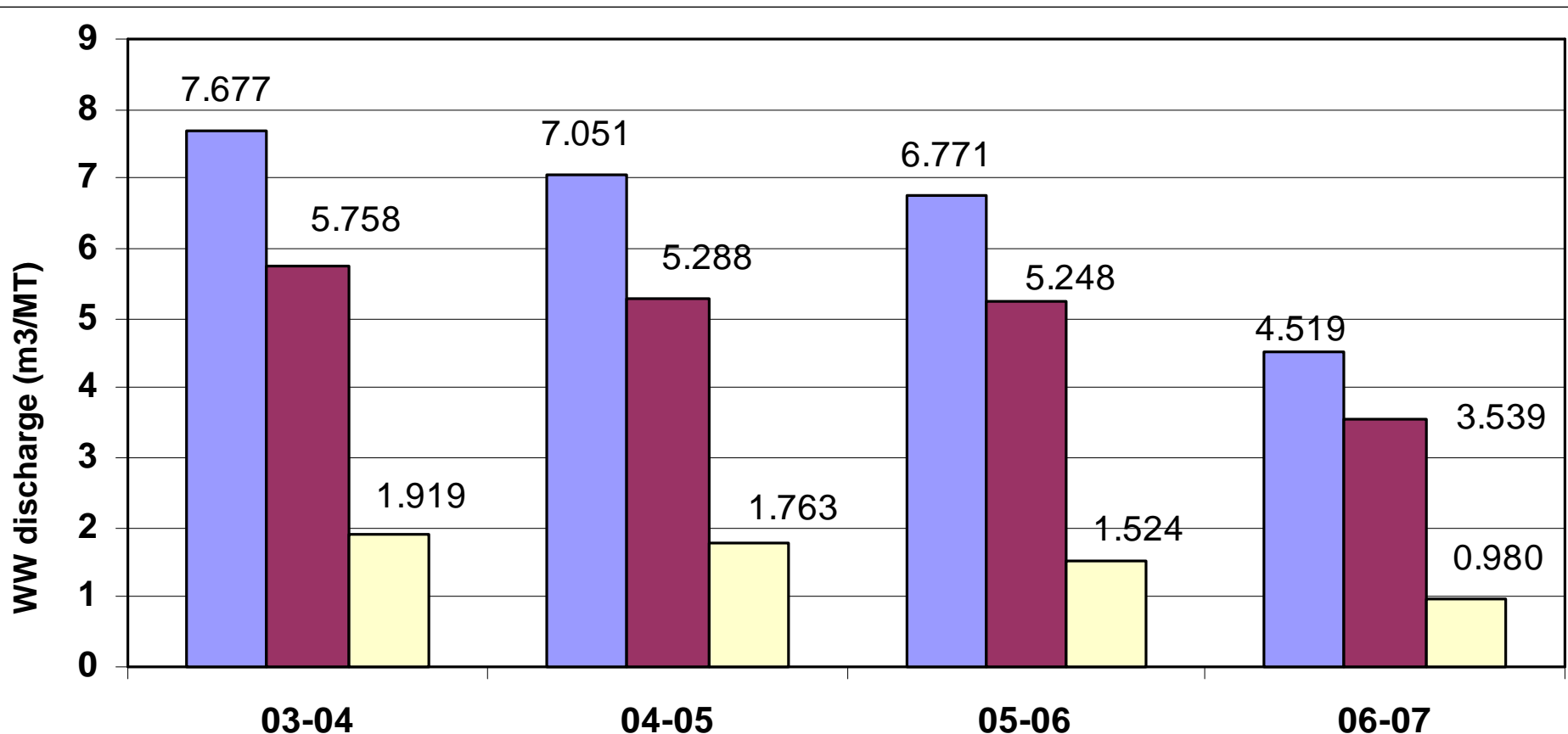

- Total WW discharge/ MT of product
- Industrial WW discharge/ MT of product
- Domestic WW discharge/ MT of product

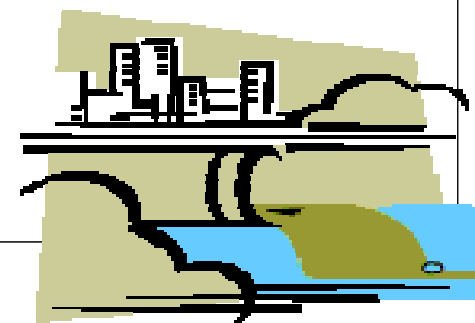

An Innovative Project of 2006-07



An Innovative Project of 2006-07



An Innovative Project of 2006-07

Project:

Water conservation by diverting Continuous Blow Down (CBD) water from Aux. Boilers to Cooling Tower sump.

Description:

- Ø CBD water from Aux. Boilers (viz. Mitsui & BHEL) expanders were drained into open trench.
- Ø Diversion to Cooling tower sump by laying 6" header from boilers region interconnecting the header with all the expanders of the Boilers

Benefit to the environment :

- Ø Hot water is not sent to the open trench now. Instead, it is safely diverted to cooling tower sump.
- Ø Water make –up to Cooling tower is reduced.
- Ø Water flows thru' a 300 m header which is non-insulated, so that it cools down significantly.

An Innovative Project of 2006-07



**New 6" header connecting to
expander of the Aux. Boiler**

**Photograph showing new header laying which is connected to expander of an
Aux. Boiler**

An Innovative Project of 2006-07

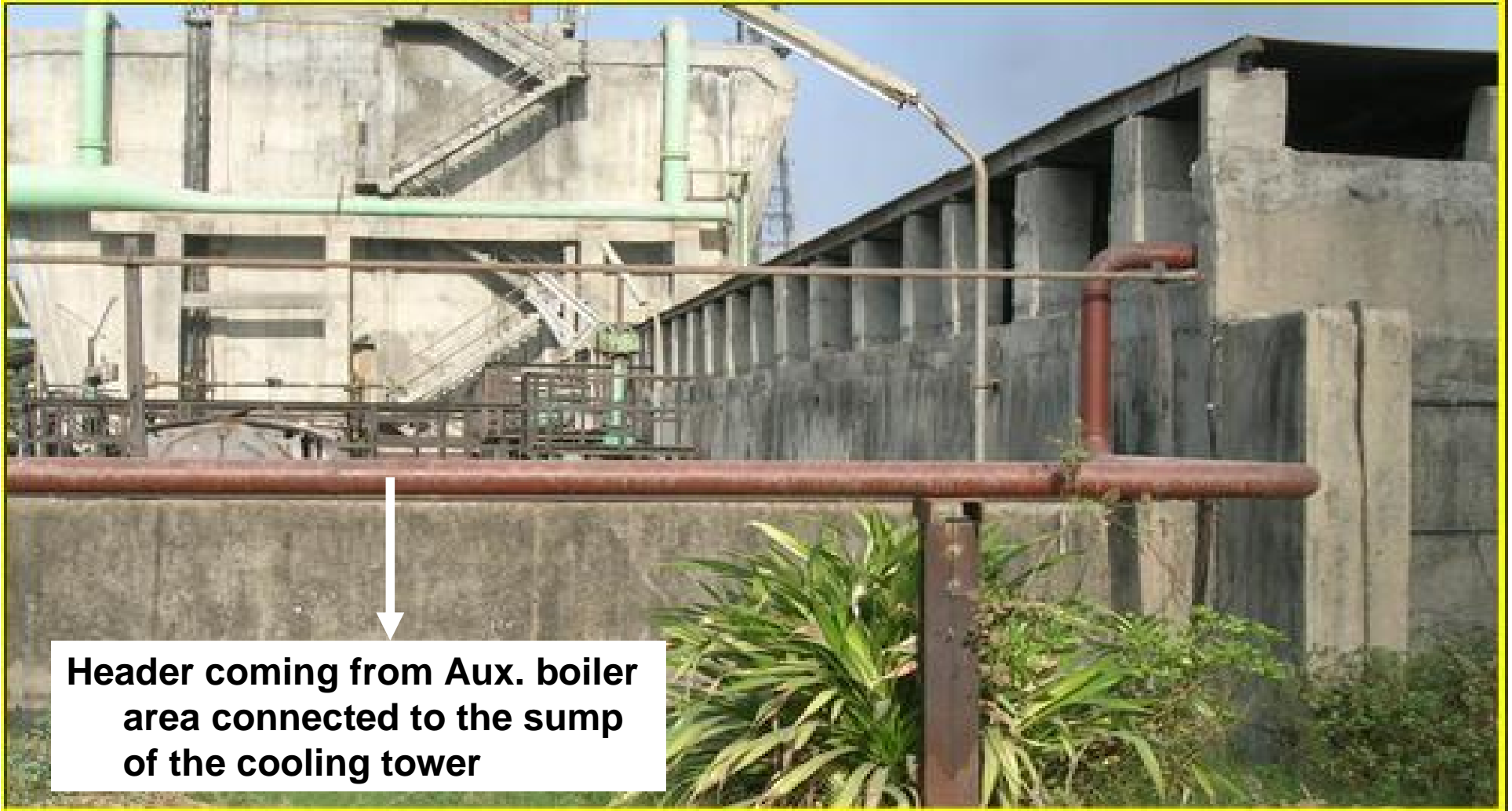

Header coming from Aux. boiler area connected to the sump of the cooling tower

Photograph showing cooling tower sump area, wherein header coming from Aux. boilers is connected

An Innovative Project of 2006-07

4. **Cost Economics :**

Av. Steam generation of 120 MT/Hr in a day

CBD = 1% of (120 x 24) per day

= 28 M3/day of water saving.

= 28 x 365

= 10220 M3/ Year

5. **Saving:** = 10220 x 7.97

= INR 81453.4

@ INR 81,500.00

Ø **Total Expenditure:** INR 80,000.00

Ø Payback Period of One Year

Ø **Implementation Date:** November, 2006

Ø Whenever Aux. Boiler is taken for IBR shut down then the whole water inside the boiler is drained to open trench, but now it is diverted to CT sump.

Ø **Replication of CT blow down scheme in other plants.**

Major Water Conservation Measures of 2006-07

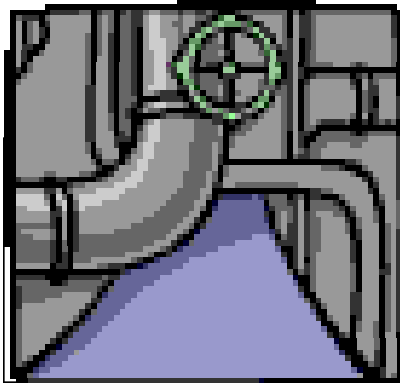

Activity	2006-07		
	Annual Saving		Inv Rs Lacs
	Water m3	Rs. Lacs	
Installation of Restricted orifice in 1200 water taps of the Complex	172037	13.7	0.05
Utilization of Polypropylene-IV Plant Effluent for Gardening purpose 	54750	4.35	0.15
Fire water tanks overflow diversion from storm water channel to Water Reservoir	1560	0.12	NIL
Diversion of once thru' Cooling water of Diesel Engine jacket to Water Reservoir	6600	0.53	0.1
Stoppage of Service water pump stoppage for Acrylonitrile plant. Water supply pr. reduced from 9.0 to 6.5-7.0kg/cm2g.	11000	12.05	NIL

Major Water Conservation Measures of 2006-07

Stoppage of Service Water pump :

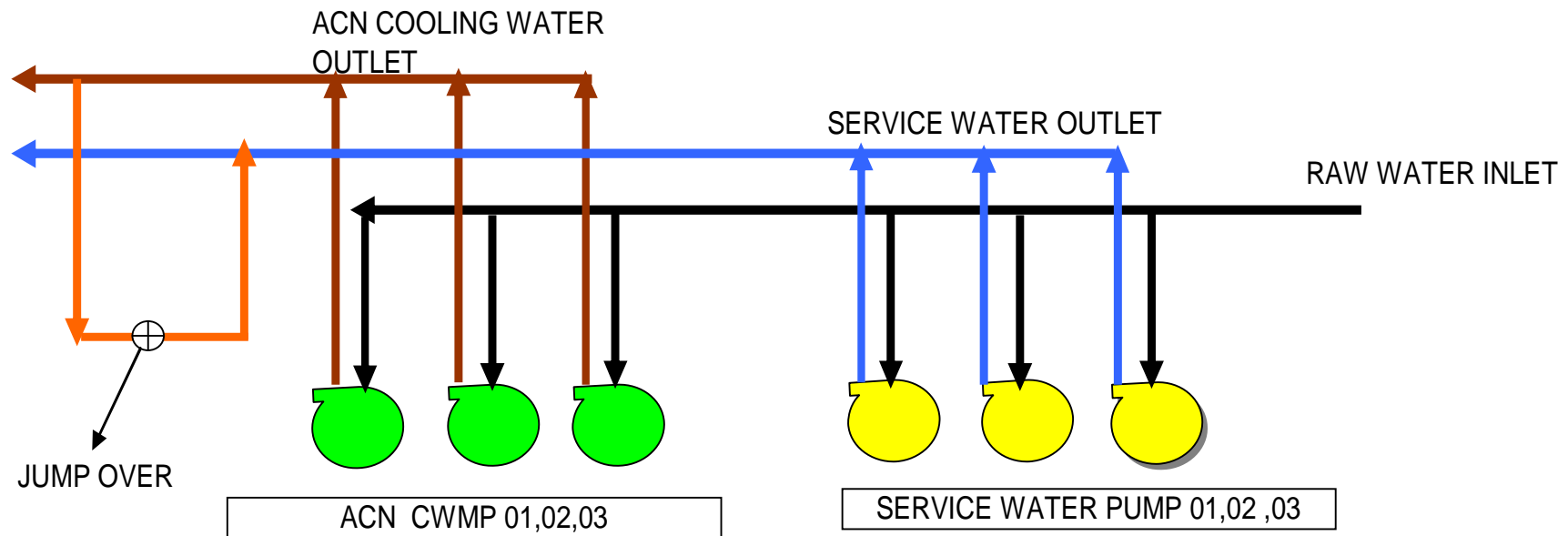

**BY THIS MODIFICATION, WE CAN SUPPLY SERVICE WATER THROUGH RUNNING ACN PUMPS,
BY THIS ARRANGEMENT WE CAN STOP TWO SERVICE WATER PUMPS AND THE SAVINGS WILL BE APPROXIMATELY
 $55\text{KW} \times 24\text{HRS} \times 365\text{DAYS} \times 2.50\text{RUPEES} = \text{Rs } 1204500/-$**

IN ADDITION, THE MAINTANENCE EXPENSES OF SERVICE WATER PUMS WILL BE NILL.

Water Conservation Measures for Continual Improvement

Activity	2004-05			2005-06			2006-07		
	Annual Saving		Inv. Rs Lacs	Annual Saving		Inv. Rs Lacs	Annual Savings		Inv. Rs lacs
	Water m3	Rs. Lacs		Water m3	Rs. Lacs		Water m3	Rs. Lacs	
Arresting water leakages (Raw water, Cooling water and Fire water)	464857	32.54		480000	34.3	NIL	426000	33.95	
Reuse of treated effluent for irrigation & Garden	-	-	-	574229	41	Nil	720000	57.2	NIL



Water Conservation – Arresting of water leakages

FIRE WATER LEAKAGES ARRESTED DUE TO LINE PUNCTURE/ CORROSION IN PLANTS OF BARODA COMPLEX - 2004(APR.) TO 2007(MAR.)

YEAR	GA P	G OP	LA B	E G	EQ	N 2 O 2	R& D	C F	A F	DS AF	I O P	G T P P	L D P E	P P C P	P P -I	PB R-I	PB R-II	PP -IV	A C N	A C R	VC /P VC	P T D + C · S t o r e s	TOT AL
04-05	13	31	6	0	4	4	4	0	0	3	0	0	2	3	4	6	10	5	2	2	15	2	116
05-06	17	15	16	0	4	0	3	0	0	2	0	1	0	1	3	1	2	4	5	2	16	1	93
06-07	14	13	5	1	2	2	10	0	1	6	4	2	1	2	2	8	8	12	2	4	11	6	116
TOTAL	44	59	27	1	10	6	17	0	1	11	4	3	3	6	9	15	20	21	9	8	42	9	325

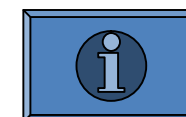

Major Water Conservation Awareness Initiatives

- ✓ Celebrating **World Environment Week** by organizing various environmental awareness (incl. water conservation) contests Suggestion Schemes, E-quiz, Skit and Slogan competitions.
- ✓ **Awareness Program for industries** thru' Presentation in Seminar / Conference at FICCI, MoEF, CII, CPCB, GPCB, ECPL and other nearby industries and villages.
- ✓ Scheme for Awarding of the **Best Environment Coordinator** under **Green Card Rating System** which includes measures for water conservation.
- ✓ Regular **Onsite Awareness programs** for Plants.

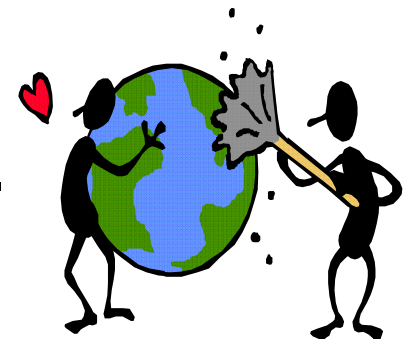

Special Initiatives

- ✓ **Development of Water Conservation projects.**
Currently one Project of Zero effluent discharge (phase wise implementation) is going on and other small projects of different plants are in pipeline. 
- ✓ **Finance allocation in Annual Budget** of the plants for Water Saving Projects.
- ✓ **Faster Clearance** of Water Saving Projects by prioritizing.
- ✓ **Six Sigma Project for Water Conservation.**



Major Environment Improvement Measures



Sr No	Description of Environmental improvement measures undertaken	Investment Rs Lakhs	Savings Rs Lakhs / annum
1	Recovery of Compressor seal leak at Cracker Plant . The gases instead of venting have been diverted 1 st stage suction of Charge gas compressor.	3	250
2	DEFINE project at LAB plant to reduce generation of byproduct / wastes by hydrogenation. Reduction in hazardous Calcium Fluoride waste generation from 1.84 to 0.887 MT/ MT of Linear Alkyl Benzene product.	765	1200
3	Stopping flaring of -- Non Condensibles from Butadiene plant extraction section and Vinyl Acetylene stream from acetylene wash column by diverting to fuel gas system .	5	240
4	Stopping flaring and recovering light ends from overhead of light end removal column of PG Propylene plant (Feed Preparation Unit).	10	47
5	Reducing Benzene loss and exposure of operating staff at Poly Butadiene Rubber Plant-- Reducing of Carcinogenic Benzene loss to atmosphere from 38 to 24 kg / MT of the PBR product by using LDAR Program.	3	170
6	Reducing generation of the Hazardous waste -EDC-Heavy ends from VCM production plant from 0.034 to 0.021 MT / MT of VCM.	5	70
7	Reducing Ethylene loss from vent of oxy-chlorinator at VCM Plant .	5	100
8	Stopping Steam venting by revamp of Steam and Condensate system in Polypropylene co-polymer plant	10	80
9	Reducing Hazardous waste (Polymeric oil) generation from Polypropylene (PP-IV) Plant from 2 to 0.75 MT / Month.	Negligible	
10	Complete substitution of liquid fuel at Utility boilers by cleaner utilizing fuel Gas	--	20

Water Monitoring Report

PLANT / UTILITIES SYSTEM	IOP DM WATR (M3)		RAW WATER (M3) IOP		IOP Cooling Water (KM3)	
UTILITY CODE	27510	STD/ACT		STD/ACT	27610	STD/ACT
ACN	6175	1.63/1.89	17453	6.5/5.35	0	
PBR-I	14484	5.1/5.31	700	0.3/0.26	510	
LDPE	2970	0/0.38	0		0	0.24/0.19
EO/EG	3700	1.88/1.93	0		0	
LAB	3	0.48/0	0		0	
GOP Cracker	65009	2.95/2.77	0		0	
IOP STEAM	0		0		63	
IOP Cooling Water	0		2180	0.47	0	
IOP Compressed Air	0		0		36	
IOP DM Water	0		181303	1.2/1.17	0	
WS Process IOP	0		4053		0	
IOP Refrigeration (PBR)	0		0		422	
IOP Refrigeration (AF)	0		0		422	
IOP STG	0		0		500	
VCM	1538	0.3/0.7	898	0.2/2.46	0	
VCM Cooling Water	0		54276		0	
PVC	8100	4.2/5.93	3916	295/519	0	
PPCP	186	0.08/0.05	0		725	
GTPP	36637		0		634	0.18/0.21
PBR-II	4660	1.1/1.27	0		0	



Water Monitoring Network

RAW WATER NETWORK

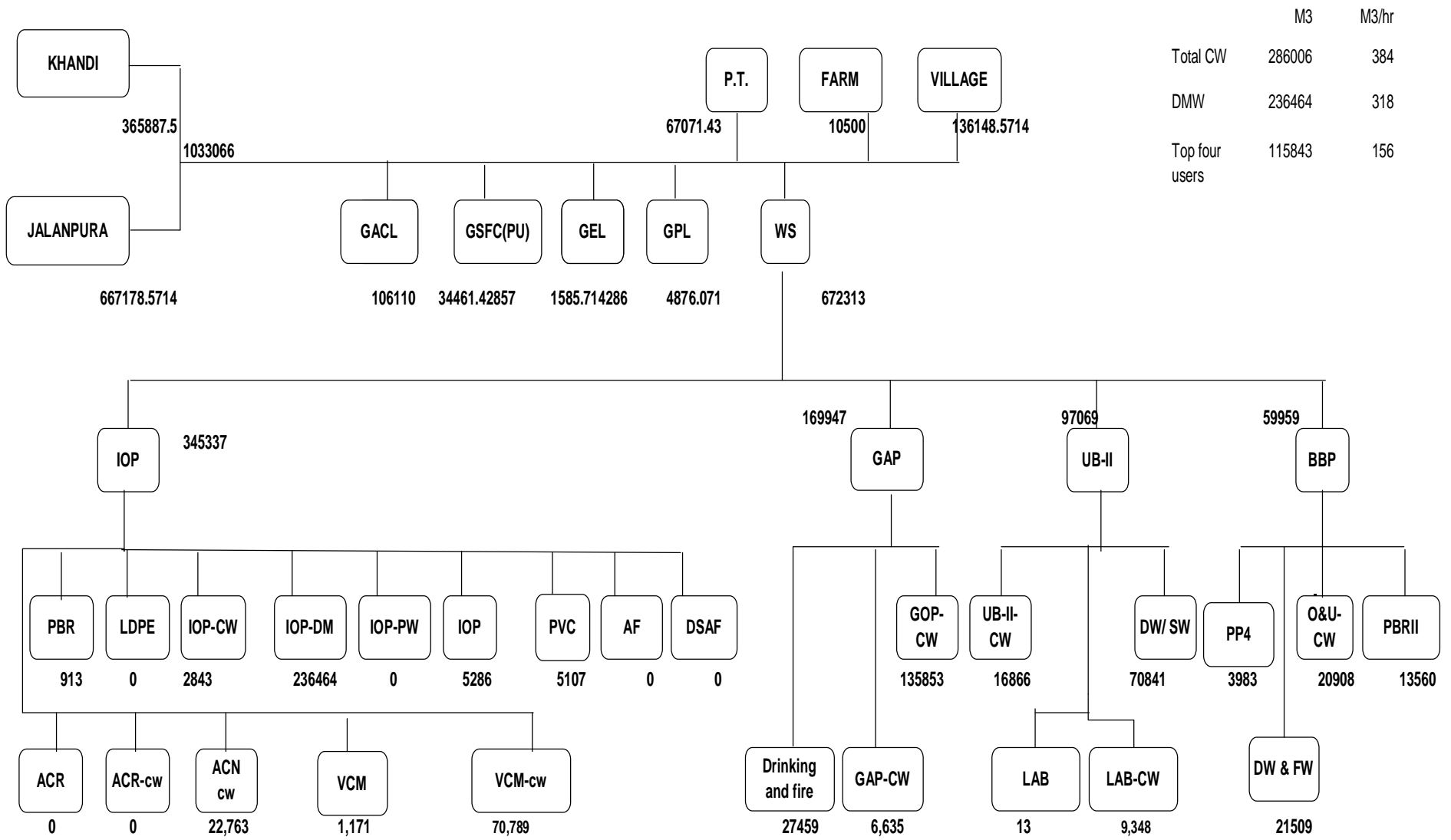

	M3	M3/hr
Total CW	286006	384
DMW	236464	318
Top four users	115843	156

All Figure are in M3

Benchmarking - National (Water Consumption- 2006-07)

RIL Sites	Production	Water Cons.	Sp. water cons.
	MT	M3	M3 / MT
Patalganga	1021848	2855495	2.79
Hazira	6673875	32130328	4.81
Vadodara**	1037979	8901135	8.58
Gandhar	1843938	13780210	7.47
Nagothane	1045641	7718645	7.38
Kurkumbh	77965	1396461	17.91

** The information of RIL(VMD) is not comparable due to difference in plant vintage, product mix, capacity and methodology of estimation both for national and international.

Benchmarking - National (Waste Water Discharge-2006-07)

RIL Sites	Production MT	Waste Water discharged	Spec. Waste water discharge
		M3	M3 / Ton
Patalganga	1021848	1790997	1.75
Hazira	6673875	10584817	1.59
Vadodara**	1037979	3673522	3.54
Gandhar	1843938	1352264	0.73
Nagothane	1045641	2049187	1.96
Kurkumbh	77965	343736	4.41

** The information of RIL(VMD) is not comparable due to difference in plant vintage, product mix, capacity and methodology of estimation both for national and international.

ACHIEVEMENTS

- ✓ **Ministry of Power’s “National Energy Conservation Award” - 6 Times.**
- ✓ **CII’s –”National Award for Excellence in Energy Management” in 2002, 2005 and 2007.**
- ✓ **GAIL’s – “Award for Excellence in Natural Gas Conservation” in 2005.**
- ✓ **IMS System - ISO 9001,ISO 14001 & OSHAS 18001 Certification for all the plants & depts.**
- ✓ **Several Safety Awards from NSC, USA, BSC, UK including Sword of Honour twice.**
- ✓ **FICCI & Indo-German Green-Tech Award for Environment preservation and pollution control.**



Forward Path



- ✓ Zero effluent discharge. 
- ✓ Converting phase wise all underground fire water line to above ground.
- ✓ Improving COC of boiler water and cooling water systems.
- ✓ Rain Water Harvesting (Phase wise).
- ✓ Replication of BFW blow down diversion to Cooling Tower sump scheme in other plants.
- ✓ Total elimination of pending once through drainage from plants.

The Spirit of Sustainable Development

May our drive for Water Conservation never fail and may our generations to born on earth not be devoid of a precious resource of life



...Rainwater harvesting...

THANK YOU



FIRE WATER LEAKAGES 04-05

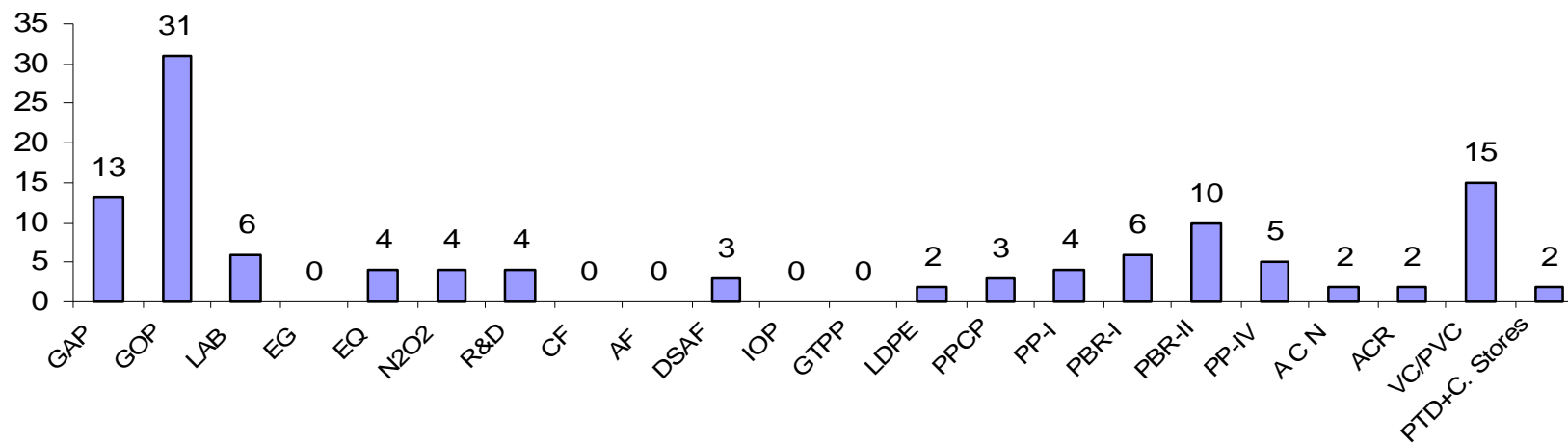

FIRE WATER LEAKAGES 05-06

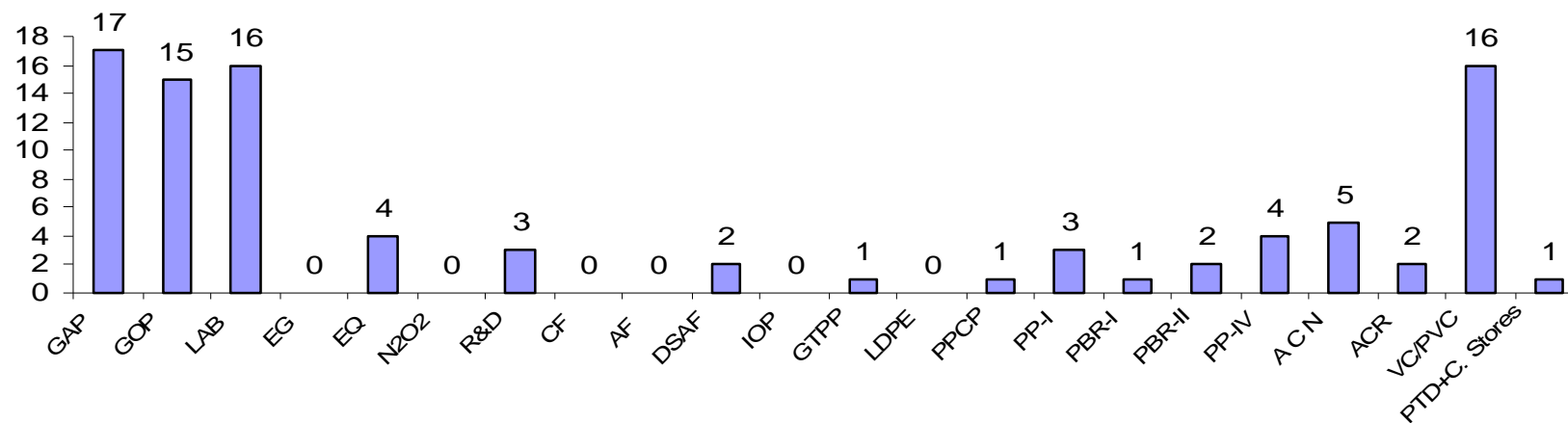

FIRE WATER LEAKAGES 06-07

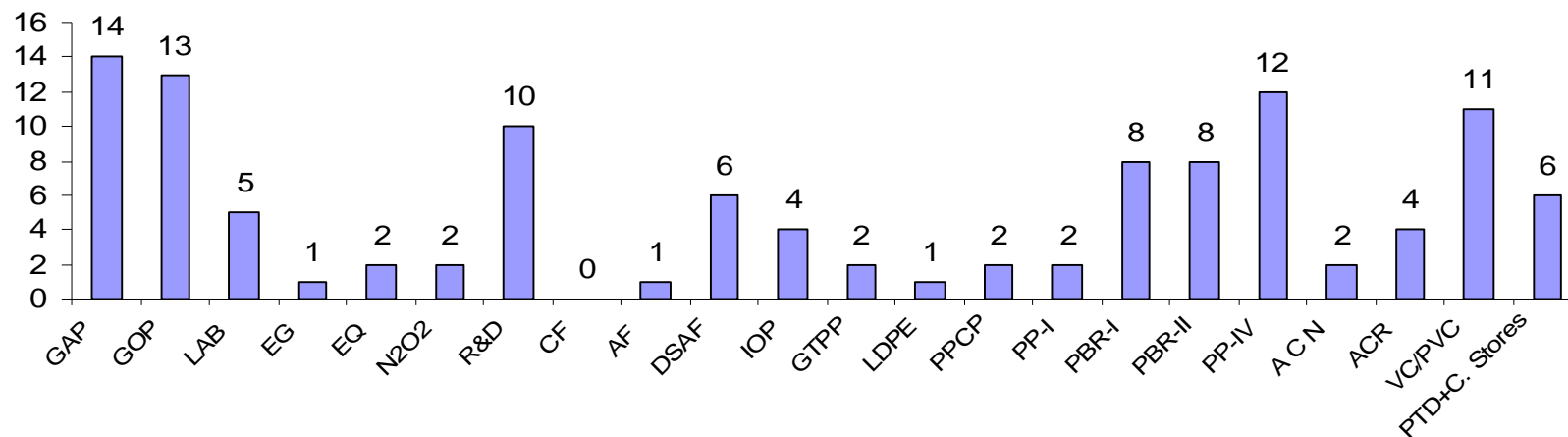

TOTAL LEAKAGES 04(APR.)-07(MAR.)

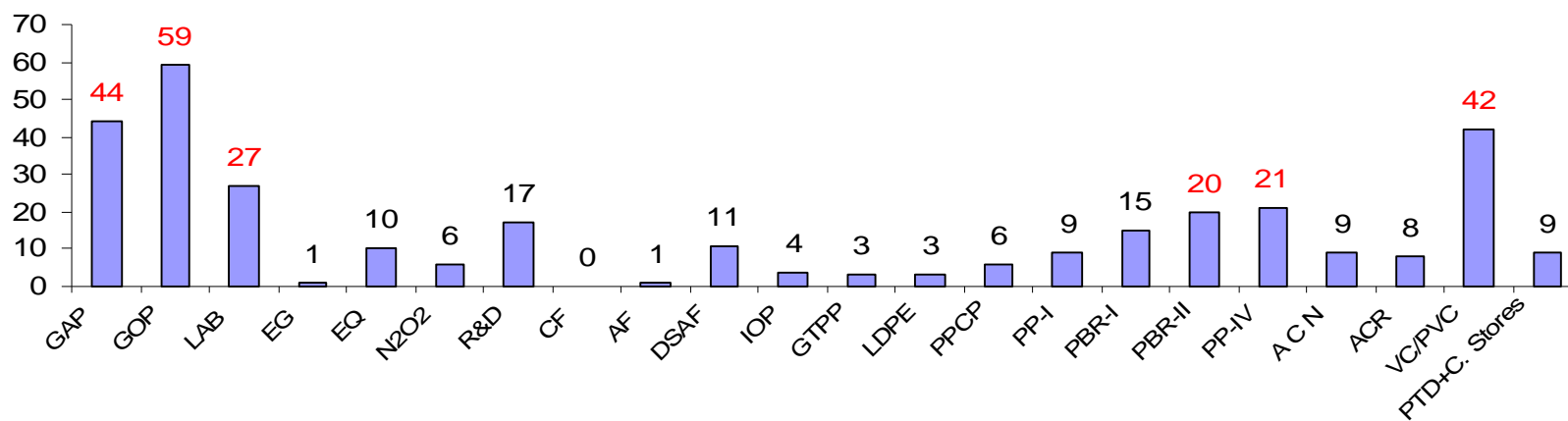

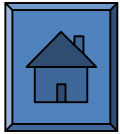

Piping network for Effluent reuse within c

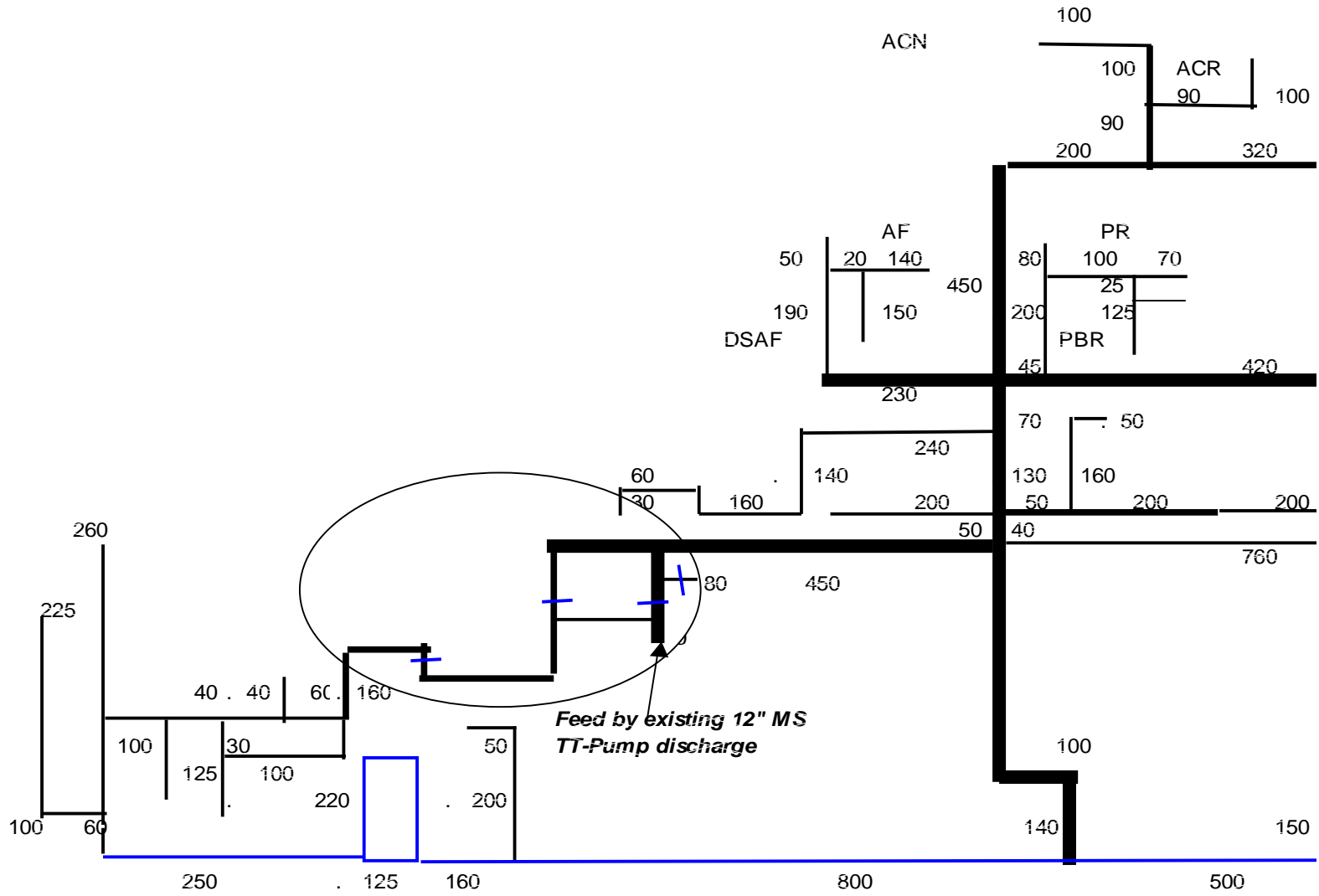

Plant Daily Effluent Quantity

Date	Apr-07	May-07	Jun-07	Jul-07	Aug-07	Sep-07	Oct-07	Nov-07
1	290	300	240	350	320	220	310	250
2	20	300	320	350	340	320	360	300
3	0	290	240	310	340	350	410	270
4	0	300	320	300	330	270	350	300
5	0	290	230	320	320	240	350	310
6	0	300	140	350	360	330	280	170
7	0	360	210	320	280	280	330	280
8	190	270	350	380	350	340	230	300
9	180	280	270	310	320	320	370	260
10	290	350	260	400	340	320	300	280
11	280	330	260	330	350	360	210	290
12	80	270	270	290	400	340	370	310
13	170	330	240	350	330	320	170	320
14	330	350	260	310	290	280	200	280
15	250	240	300	310	300	330	290	280
16	280	270	280	300	300	360	270	260
17	280	250	230	300	310	250	310	310
18	310	350	230	320	360	400	60	300
19	330	310	230	210	310	330	10	300
20	270	310	330	320	320	320	0	300
21	250	290	240	330	310	300	180	270
22	350	320	370	320	300	310	340	310
23	320	310	270	320	270	400	260	
24	300	300	400	320	300	300	260	
25	290	330	310	300	300	320	360	
26	300	280	330	330	320	310	310	
27	290	330	220	250	250	500	360	
28	330	300	240	300	310	250	320	
29	230	280	140	340	330	390	330	
30	350	350	270	260	300	340	350	
31		290		310	310		390	
MIN	0	240	140	210	250	220	0	170
MAX	350	360	400	400	400	500	410	320
AVERAGE	219	304	267	316	318	323	279	284
TOTAL	6560	9430	8000	9810	9870	9700	8640	6250

Date	Screw pump	NT	Sp.caust	CN	FEPH
	Flow	Flow	Flow	Flow	MGD
1-Apr-07	9410	1520	24.0	216	3.34
2-Apr-07	9900	1760	24.0	216	3.19
3-Apr-07	8630	240	24.0	216	3.21
4-Apr-07	10250	960	24.0	216	3.23
5-Apr-07	7850	880	24.0	216	3.07
6-Apr-07	8680	880	24.0	216	2.14
7-Apr-07	9170	880	24.0	216	2.48
8-Apr-07	7530	1380	24.0	216	2.71
9-Apr-07	7360	1200	40.0	216	2.88
10-Apr-07	7830	3080	48.0	216	2.24
11-Apr-07	9370	1200	48.0	216	2.98
12-Apr-07	7990	680	29.0	216	2.73
13-Apr-07	7560	1200	29.0	216	2.75
14-Apr-07	7300	1760	29.0	216	2.67
15-Apr-07	8000	1520	29.0	216	2.85

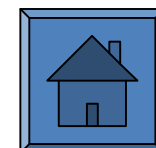

Zero Discharge Project Status



Sr. No	Identified stream	App.Quantit y, M3/Day	Forward path	Status	Target
1	Treated Effluent	4000	Revival of TT Plant for reuse in cooling	C&I Inspection & elect.job completed	March 08
2	Treated Effluent	1000	Laying of pipeline network for reuse in garden	1200 mt.Line(Out of 2000mt.) laid towards south road.Started using effluent.	Nov.07
3	PVC centrate water	700	S.S.removal & Reuse for cooling	Offer received on 22/10 from M/S ION Exchange	March 08
4	PBR I/II Finishing section effluent	300 + 300	Recycle to Cooling water makeup after heavy metal(Trace) removal	Under review with R&D & ION Exchange	March08
5	IOP DM plant regeneration effluent	1000	M/S ION Exchange, to study for reuse and report	Data submitted, Report expected Nov.07	March 08
6	Township senatory waste	3500	M/S ION Exchange, to study and report	Data submitted. Report expected Nov 07	March 08
7	PP IV Effluent	200	Recycle for cooling water makeup	Offer received on 22/10 from ION exchange	March 08

Garden at Polypropylene-IV



Per capita water consumption

(Within the fence)

Year	Consumption (m3)	Avg. employees per day	Per capita consumption ltr/person/ day
2003-04	886457	8330	291.6
2004-05	878230	8200	293.4
2005-06	860183	7670	307.3*
2006-07	671294	7590	242.3

This includes drinking, washing, toilets, cooking, watering plants, cleaning and doesn't include recycle water consumption.

* Trainees are not included as employees.