

PLASTICS IN PACKAGING OF DRINKING WATER

By

Dr. SANIA AKHTAR

CIPET, MYSORE



CIPET-MYSORE

Welcomes you





TEAM CIPET MYSORE





CIPET

OBJECTIVES

- **Research & Development in the field of plastics**
- **Quality control and standardization of plastic materials and products.**
- **Technical Consultancy and advisory services.**
- **Design and development of moulds, dies and plastic product**
- **Application development in the area of plastics**
- **Import substitution for developing scarce natural resource through the use of plastics**
- **Promotion of entrepreneurship.**
- **Development of skilled manpower for plastics industry.**
- **Up-gradation of technical knowledge through advanced training programmes.**



Infrastructure & Facilities

Design and CAD/CAM/CAE Centre

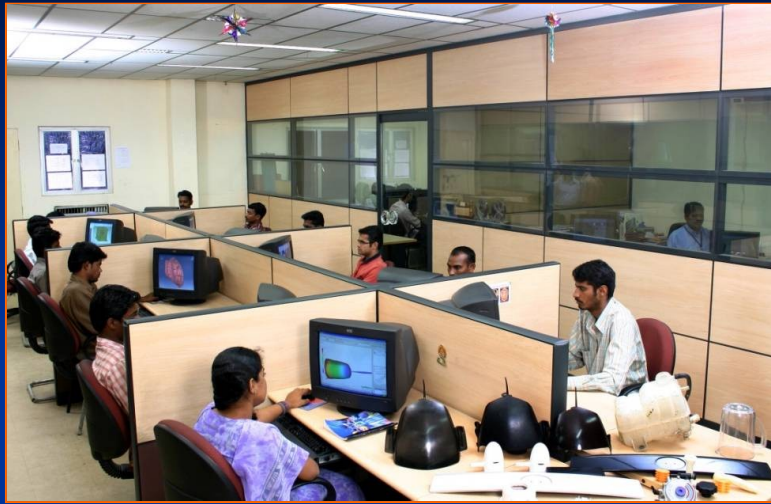

**CAD/CAM
Software**

MOLD FLOW

PRO-E

CATTIA

UNIGRAPHICS

AUTO CAD

IDEAS

MECHANICAL

DESKTOP

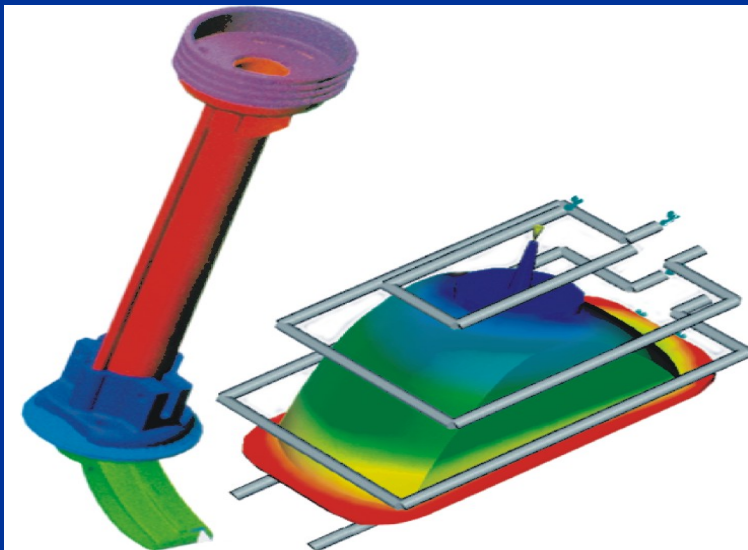

Infrastructure & Facilities

Tool Room



CNC Five Axis Milling HAAS

**CNC Milling
MIKRON/Switzerland**



**CNC Lathe, HAAS & TORNADO/
UK**

**CNC-EDM,
Charmilles/Switzerland**



CNC Wire Cut EDM, Electronica

**Conventional machines –
Lathe, Milling, Grinding,
Shaping, Surface Grinding,
Polishing etc.**

Plastic Processing



- Injection Molding machines
 - DGP Windsor
 - Sumitomo 180 tons
 - Engel Tiebarless 80 tons
- Thermoforming machine
- Blow Molding machine
- Pipe Extruder
- Blown film Extruder
- Compression Molding machine
- Two roll mill



Infrastructure & Facilities

PLASTICS TESTING

- Computerised Torque Rheometer, - Haake/Germany with single/twin screw, Sigma mixer & down stream calendaring, blown film and strand pelletizing units
- Computerised UTMs, Instron & Lloyds/ UK,
- Impact Izod/ Charpy tester, ATS Faar/Italy
- Atlas Xenotest Haereus/Germany for weathering studies
- LOI & smoke density for flammability studies, Atlas/USA.
- Atomic Absorption Spectrophotometer
- DSC & TGA for Thermal Analysis
- FTiR

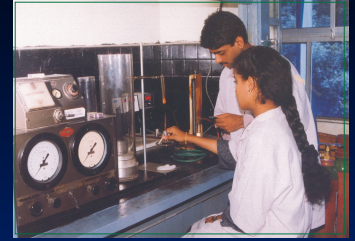



CIPET

LONG TERM COURSES

- **M.Tech-PE/PT- Plastics Engineering/Technology**
- **B.Tech-PE/PT - Plastics Engineering/Technology**
- **PGD-PE - PG Diploma in Plastics Engineering**
- **PGD-CAD PE - PG Diploma in CAD-Plastics Engineering**
- **PD-CAD PMD - Post Diploma in CAD-Plastics Mold Design**
- **PGD-PPT - PG Diploma in Processing and Testing**
- **DPT - Diploma in Processing Technology**
- **PD-PT - Post Diploma in Processing Technology**
- **DPMT - Diploma in Plastics Mold Technology**
- **PD-PMT - Post Diploma in Plastics Mold Technology**

PACKAGING OF DRINKING WATER





GLASS vs. PLASTICS

Greenhouse Gas Pollutants per 1000 bottles (metric tons)

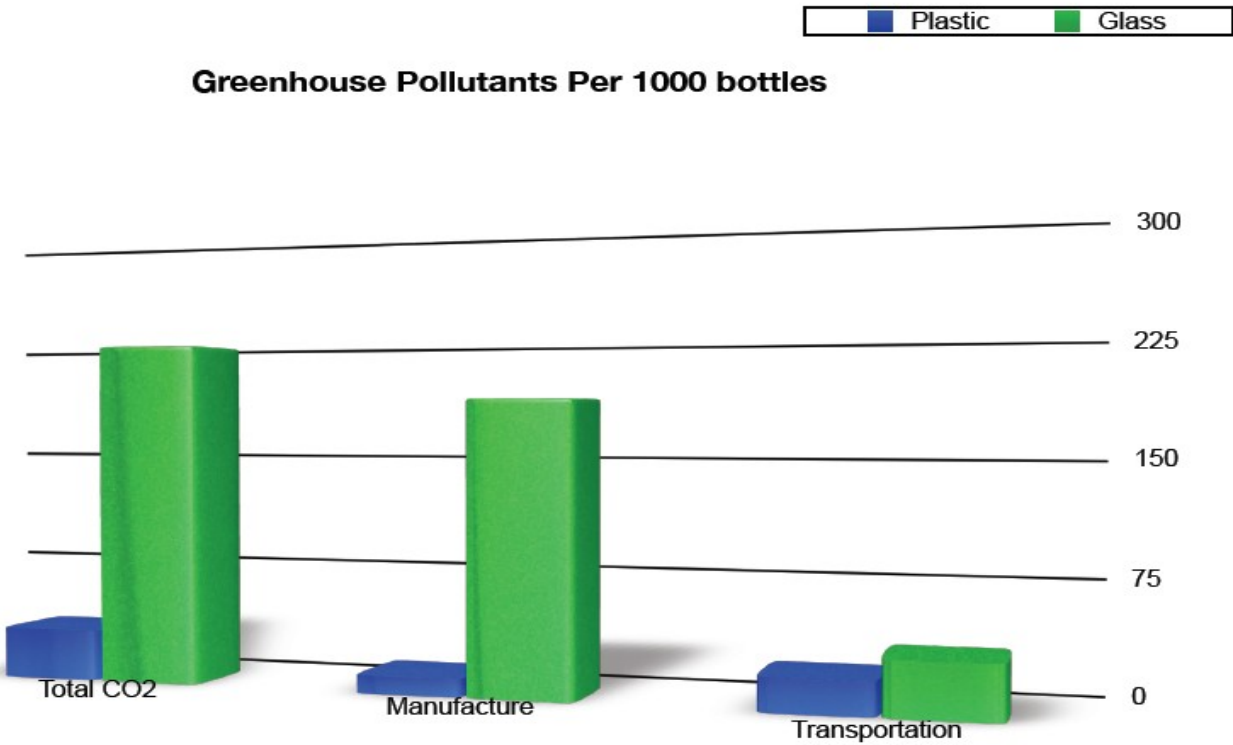

Glass creates nearly **seven times more** global warming gases than plastic.

The above information is summarized from the Economic Input-Output Cycle Assessment by Carnegie Mellon University Green Design Institute (2008)

Energy Consumption per \$1 million Product (Terajoules)

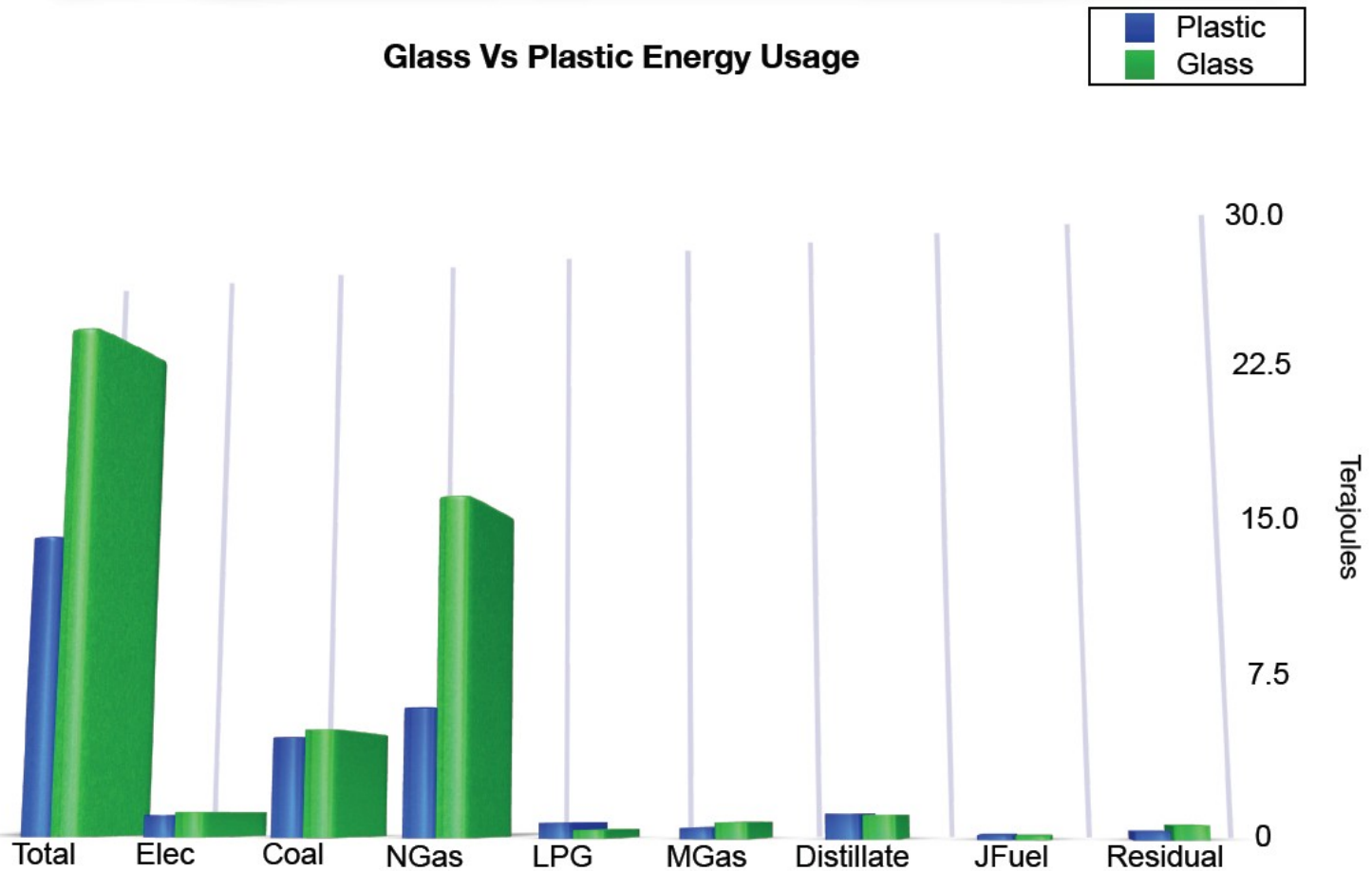

Glass consumes nearly **two times more energy** to produce than plastic.

The above information is summarized from the Economic Input-Output Cycle Assessment by Carnegie Mellon University Green Design Institute (2008).

Air Pollutants per \$1 million Product (metric tons)

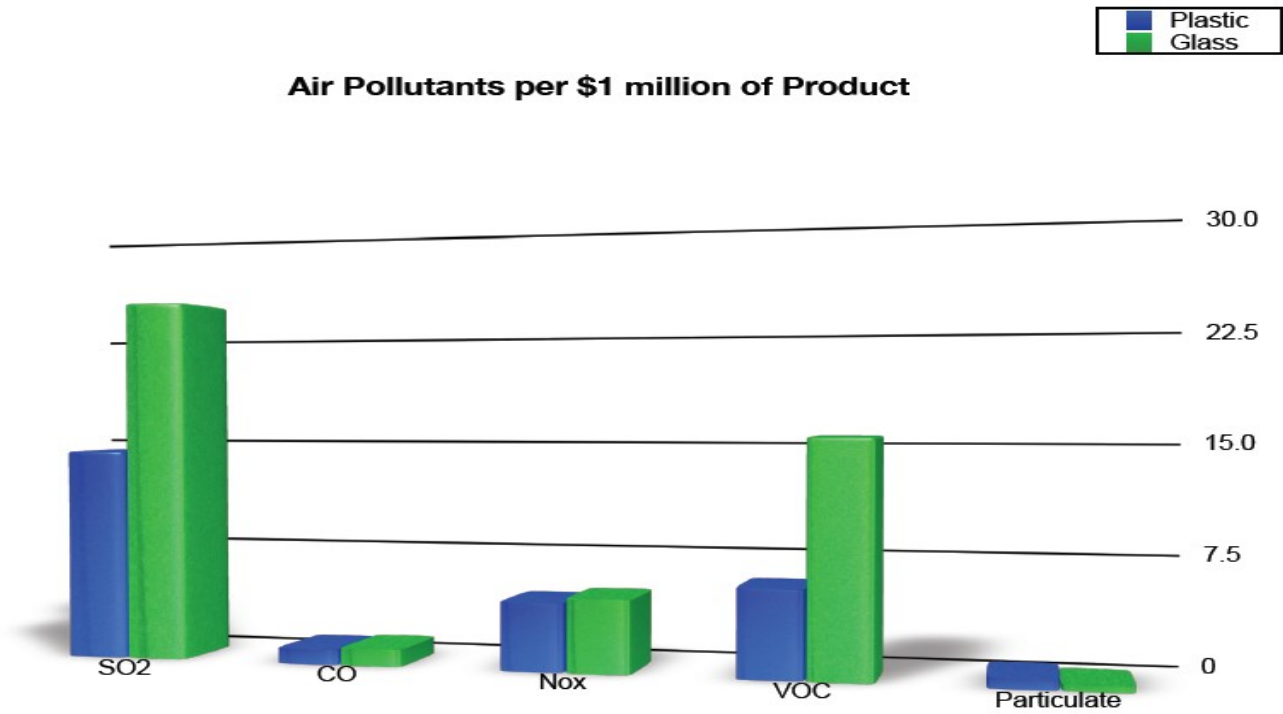

Glass produces nearly **three times more air pollution** than plastic.

The above information is summarized from the Economic Input-Output Cycle Assessment by Carnegie Mellon University Green Design Institute (2008).

Glass recycle rates are only marginally higher than plastic (67%- glass, 54%- plastic)

State of California Dept. of Conservation 2007.

This is a real eye opener. Maybe glass isn't all it's cracked up to be. Even if no energy was involved in the transport and cleansing of returnable bottles, returnable bottles would have to be recycled about 20 times to compete with plastics.

Plastic seemed to be a **better solution, ecologically**, but we still had concerns about the toxic leaching associated with it. We discovered that plastic with the PET #3, #6, and #7 use chemicals associated with toxic leaching.

An ideal solution would be for us to find a material with none of the associated pitfalls, yet all of the benefits of both glass and plastic.



Essential Requirements for Packaging

- Packaging weight and volume must be reduced to the minimum necessary for safety, hygiene and consumer acceptance of the packaged product.
- Hazardous substances and materials must be minimised as constituents of packaging, with specified limits on named heavy metals
- Packaging must be suitable for at least one of the following – material recycling, energy recovery or organic recovery.
- Packaging which is claimed to be reusable must be suitable for that purpose and for at least one of the three recovery methods specified above.



Packaging Requirements

It is well known that drinking water should be packed in clean, colourless, odourless, clear, tamperproof containers, which are hygienically safe.

Much of the water is packaged in similar bottles as carbonated soft drinks, and would, therefore, carry many of the same requirements



Properties required of the packaging

■ Strength

Unlike carbonated drinks, the bottles filled with still water need only enough strength to hold water and to survive impact.

■ Colour and Clarity

Clarity is one of the most important requirements and is the main reason why clear bottles of plastics are used. A resin with higher levels of co-polymer adds to the clarity. In India, the BIS (Bureau of India Standards) has prescribed colourless bottles for multi trip/reusable containers.



- **Purity**

Because water is a flavourless product, using a plastic that remains tasteless and odourless is imperative.

- **Mandatory Certification**

To prevent adulteration, the quality of the bottle and its sealing has drawn great attention and concern. The provisions of mandatory BIS certification and that of Prevention of Food Adulteration Act (PFA) have brought in assurance to the consumers that packaged drinking water is trustworthy.



Standards for Packaged Drinking Water

- IS : 14543 - 1998 (Specification for Packaged Drinking Water) prescribes the hygienic practices to be followed in respect of collecting water, its treatment, bottling, storage, packaging, transport, distribution and sale for direct consumption , so as to guarantee a safe, hygienic and wholesome product.



Safety Process for Bottling Water

- | | |
|---|---|
| <ol style="list-style-type: none">1. Source selection and monitoring2. Source water receiving and monitoring3. Water Storage and monitoring4. Micro-filtration5. Ultraviolet Light/ozone disinfection | <ol style="list-style-type: none">6. Packaging Control7. Bottling Control8. Clean-in-place sanitation process9. Plant quality assurance and HACCP program10. Quality Assurance System |
|---|---|









**MYTHS ABOUT
PLASTICS**
Freezing water causes the release of chemicals from plastic bottles.

Antimony trioxide (ATO) in PET is a Health Hazard

Plastics contain dioxins, a group of contaminants labeled as “likely human carcinogens” by the Environmental Protection Agency.

Some plastic bottled water packaging contains chemical phthalates and Bisphenol A which may mimic human hormones and adversely affect the body’s normal functions

PLASTICS MATERIALS FOR PACKAGING

Plastic Identification Symbol and Abbreviation(s)	Plastic Type and Examples of Uses
 PET or PETE	Polyethylene terephthalate (e.g., soft drink and bottled water)
 HDPE	High density polyethylene (e.g., grocery bags, base cups, and beverage bottles)
 PVC	Polyvinyl chloride (e.g., pipes)
 LDPE	Low density polyethylene (e.g., various containers, dispensing bottles, and tubing)
 PP	Polypropylene (e.g., food containers)
 PS	Polystyrene (e.g., cafeteria trays and toys)
 PC or OTHER	Polycarbonate (PC) or other plastics, including acrylonitrile, butadiene styrene acrylic, polylactic acid, nylon, and fiberglass.

Recycling

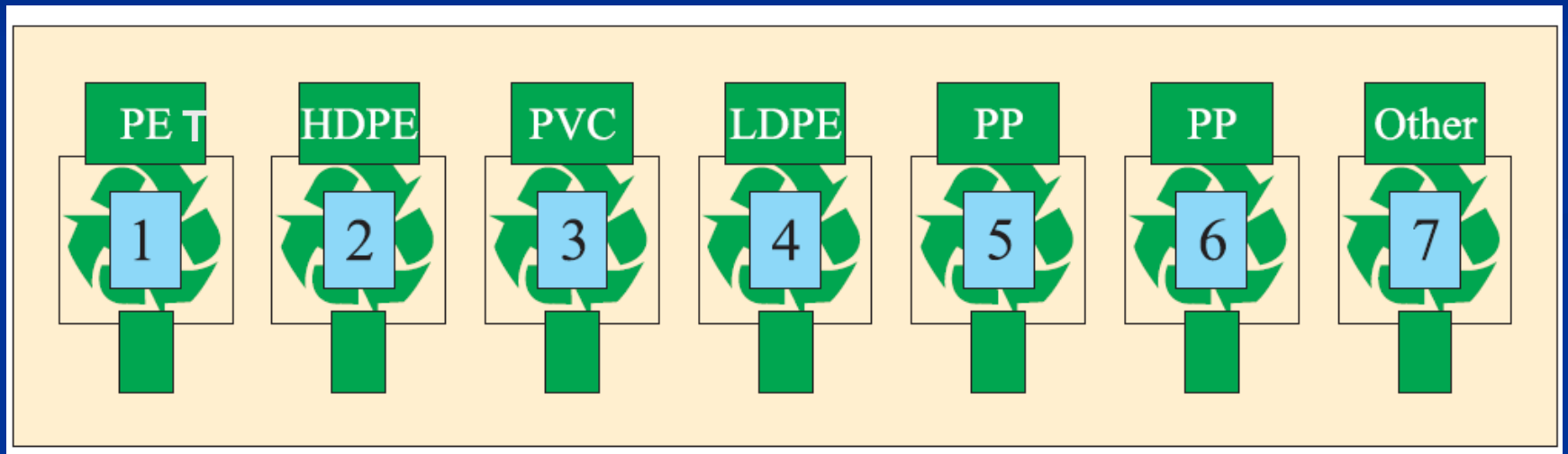



PET CONTAINER



PET

- High transparency
- Low weight
- Unbreakable/High firmness
- Very good mechanical characteristics
- Good barrier properties (to oxygen, CO₂, water)
- No taste on the filling mediums
- Good form stability
- Capability for hot filling
- High Recyclability
- Health Authorities approval
- Economic production

PET

The properties of PET are modified with addition of monomers and additives which influence the following:

- Clarity
- Colour
- Melt behaviour
- AA reformation
- Crystallinity
- Molecular Weight Distribution

PET RECYCLING



PET is the most extensively recycled plastic of the present time. It is easier to collect than other plastics.

- **It has a high intrinsic value, is economic to recycle even with existing collection systems and there are well-developed markets for its recycling.**
- **Cleaned, recycled PET flakes and pellets are in great demand for spinning fiber for carpet yarns, producing fiberfill and geo-textiles.**

PET RECYCLING

Another important feature of used PET is its ability to be converted chemically to the monomer from which it was produced using hydrolysis or methanolysis. The US FDA for food-packaging applications have approved PET produced by chemical recovery of this sort.

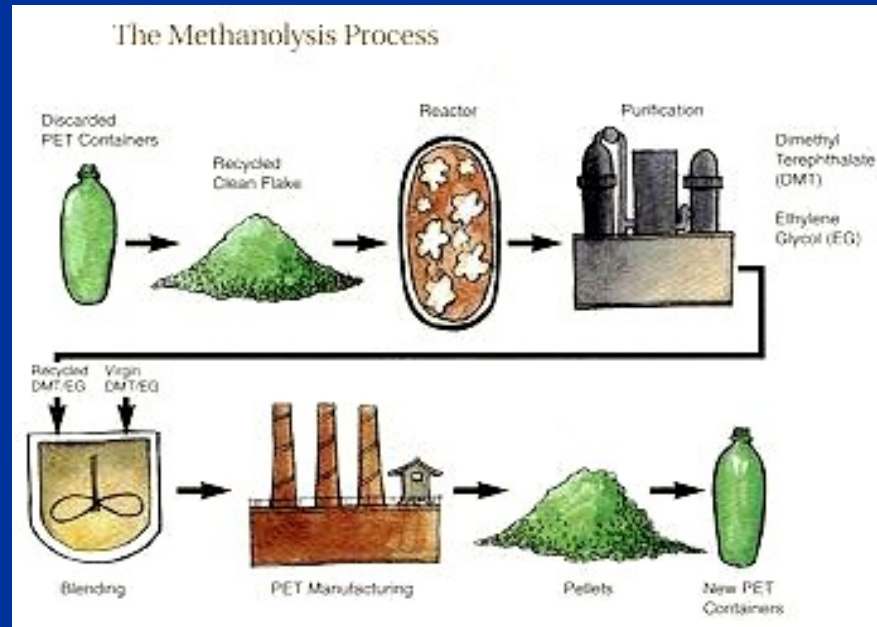

PET Re-use

- PET bottles are recycled as-is for use in solar water-disinfection in developing nations, in which empty PET bottles are filled with water and left in the sun to allow disinfection by ultraviolet radiation.
- PET is useful for this purpose because most other materials (including glass) that are transparent to visible light are opaque to ultraviolet radiation.

Incineration of Plastics

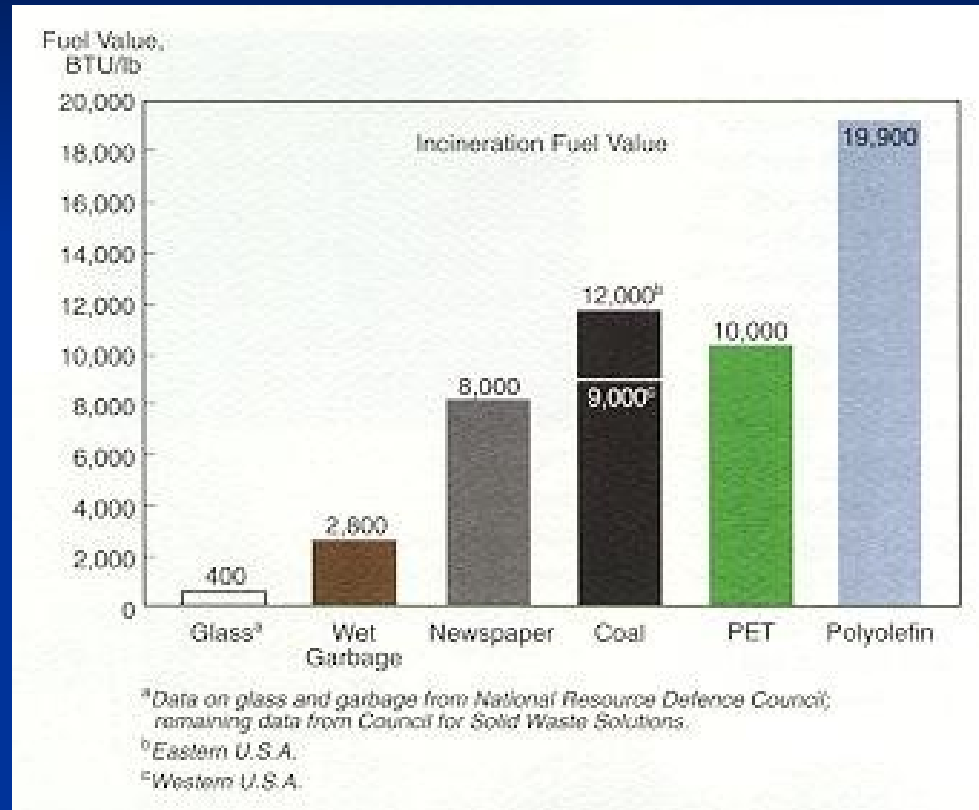



HDPE CONTAINERS FOR DRINKING WATER



HDPE

High Density Polyethylene (HDPE).

HDPE is used to make many types of bottles. Unpigmented bottles are translucent, have good barrier properties and stiffness, and are well suited to packaging products with a short shelf life such as milk.

Because HDPE has good chemical resistance, it is used for packaging many household and industrial chemicals such as detergents and bleach. Pigmented HDPE bottles have better stress crack resistance than unpigmented HDPE.



Vitamin E or alpha-tocopherol - the Solution to HDPE Taste Problem

- Antioxidants are used in plastics and plastic packaging (both rigid and flexible) to prevent damage associated with the effects of processing, heat, long-term storage, and exposure to air and atmospheric pollutants.
- Phenolic primary antioxidants have long been the most important molecules for providing this protection. BHT, Irganox1010 and 1076 (Ciba), and more recently, vitamin E or alpha-tocopherol.
- Chemists have found vitamin E to be one of the **best antioxidants**.



Vitamin E or alpha-tocopherol



- Imparts less taste and odor
- Reduces the formation of gels--or structural weaknesses--in film packaging, thereby reducing waste and allowing film to be processed at higher temperatures with faster throughput.
- Migrates less -thereby eliminating the risk of contamination caused by the packaging components.
- Provides better color stability and is more thermally stable
- It offers a reduction in additive cost although almost three times the cost/lb of other standard commercial A/Os antioxidants, it is used at only 1/4 to 1/5 the dosage level of competing products.

Poly Vinyl Chloride (PVC)



Earlier, the most commonly used package for mineral water was stretch blow moulded bottle of PVC, as PVC is rigid, clear and has adequate impact strength. Compared to other polymers, PVC requires lower amount of energy to produce. If collected separately, it can be readily recycled.





Non-toxic PVC for drinking water



(FDA) show that current residual vinyl chloride monomer (RVCM) levels in all grades of PVC resin typically are significantly below acceptable levels and that resulting fabricated products are typically at nondetect levels to very low parts-per-billion (ppb) levels. The FDA in USA and regulatory agencies have specified the monomer levels at 5ppm in PVC resin.

The recycled PVC is sandwiched between inner & outer layers of virgin polymer in co-extruded PVC pipes.

PVC containers in capacities of 100, 200, 250 and 1000ml are used for packaged drinking water.

PVC COLLAPSIBLE WATER CONTAINER

Product Description

Model Name: PVC collapsible water container

Item no: P-10

Specification: 10 litre

Size: 24x23x22cm

Material: Non-toxic PVC

Feature: Foldable, easy to carry and storage.



LDPE

Low Density Polyethylene (LDPE).

LDPE film is the most important group of plastics used in packaging drinking water.



LDPE

Polyolefins also have the highest calorific value of all constituents in the packaging waste stream and are, therefore, prime candidates for disposal through incineration with energy recovery.

- LDPE is used predominately in film applications due to its toughness, flexibility and relative transparency, making it popular for use in applications where heat sealing is necessary. LDPE also is used to manufacture some flexible lids and bottles
- Includes Linear Low Density Polyethylene (LLDPE)



Polypropylene (PP)



Polypropylene (random clarified co-polymer) is widely used for food contact applications throughout the world and enjoys favourable status with food and regulatory agencies.

PP containers/cups with peelable lids are used for packaging of drinking water in 100, 200ml. capacities with suitable lids for closures.

PS

Polystyrene (PS)

- PS is a versatile plastic that can be rigid or foamed. General purpose polystyrene is clear, hard and brittle. It has a relatively low melting point. Typical applications include protective packaging, foodservice packaging, bottles, and food containers.
- PS is often combined with rubber to make high impact polystyrene (HIPS) which is used for packaging and durable applications requiring toughness, but not clarity.

High Impact Polystyrene (HIPS)

HIPS (High Impact Polystyrene) containers cater to the 200ml mineral water market. These containers are provided with heat sealable peelable lids.

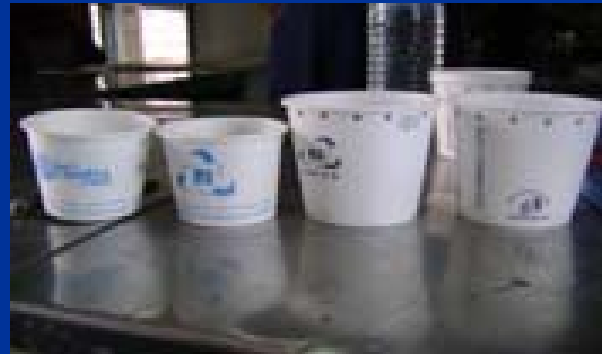



Other

Other – (PC, ABS etc.)

- Use of this code indicates that a package is made with a resin other than the six (PET-1, HDPE-2, PVC-3, LDPE-4, PP-5, PS-6), or is made of more than one resin and used in a multi-layer combination.



PC Bottles



Polycarbonate (PC)

Polycarbonate can be processed into useful end products by any of the usual processing techniques like extrusion, blow moulding, injection moulding etc. Polycarbonate containers are popularly used for multi-trip application for mineral water containers of 15-20 litres.

Polyethylene Naphthenate (PEN)

This is a high performance resin and the containers made out of this resin are used for refillable, returnable mineral water.

Water container (collapsible)



Shelf life: 10 years when kept in original packing between - 10 and + 50 degrees Celsius

Material: The container foil is composed of mixture LDPE/EVA copolymer and LLDPE raw material - (colourless, cloudy - transparent)



TPU SOFT TANKS

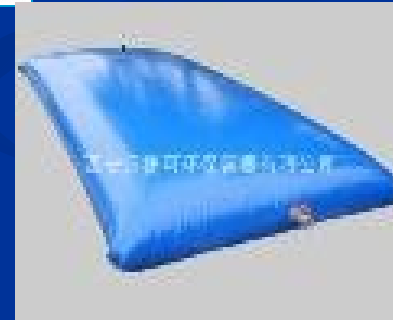



Soft drinking water tank (or bladder)

Material: TPU

Shape: pillow shape

Color: yellow, blue, orange, grey, black (color can be customized)

Capacity: 50 to 50,000 Liters

Material weight: 1000kg/sm to 1400kg/sm

Thickness of material: 0.60mm to 1.20mm



Future of soft water tank:

1. Light weight, easy operation.
2. Minimum packing size, easy for transportation and storage.
3. No contamination for water, which may guarantee the quality of the material.
4. High strength of the coated fabric, the adhesion up to 60 lb/in.
5. High strength of the seams because of the high frequency melt and sealed with the same polyurethane as the tank body, so the tanks have excellent ability against air leakage, and TPU water tank is suitable for drinking water, milk and juice, etc.



FLEXITANK



Flexitank is designed for the transportation of non-hazardous material in 20 ft containers. It is formed by four layers PE liner and one PP woven bag that meet the standards of FDA which can transport not only food-type products in liquid but also of industrial liquids. Flexitank range in size from 10 000 to 24 000 liters (depending on product density)

What can be transported with Flexitank?

Non-hazardous liquids, such as:



Food: Wine, Edible Oil, Fruit Juice Concentrate, Foodstuff Additive, Sorbitol, Palm Oil, Soy Sauce, Yellow Wine, Mineral Water, Malt Extract, Syrup, etc.,

Industrial: Lube Oil, Lub Additive, Transformer Oil, White Oil, Chinese Wood Oil, Glycerol, Coconut Oil, Synthetic Resin, Cleanser, Disinfector, Surfactant, Silicate, Glycol, PG, Fertilizer, Natural Latex, Synthetic Latex, etc.,

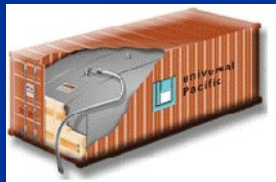



THANK YOU