

FIELD TESTING OF WEIGHING RAIN GAUGE (WRG)



आपो हि ष्ठा मयोभुवः

NATIONAL INSTITUTE OF HYDROLOGY
JAL VIGYAN BHAWAN
ROORKEE - 247 667 (U.P.) INDIA

1997-98

CONTENTS

	PAGE
ABSTRACT	
LIST OF FIGURES	
LIST OF TABLES	
1.0 INTRODUCTION	01
2.0 WEIGHING RAIN GAUGES	02
3.0 WRG CONFIGURATION	02
4.0 SOFTWARE FEATURES	06
5.0 RESULTS AND DISCUSSION	09
6.0 CONCLUDING REMARKS	19
REFERENCES	19
APPENDIX	21

LIST OF FIGURES

NO.	TITLE	PAGE
1.	Plan view of WRG	03
2.	Block diagram of rainfall measurement using WRG	05
3.	Flow chart of rainfall measurement using WRG	07
4.	Schematic of Data Logger Operation	08
5.	Testing of WRG at NIH Campus (WRG Vs SRRG)	14
6.	Testing of WRG at NIH Campus (WRG Vs ORG)	15
7a.	Rainstorm of July 11, 1996	17
7b.	Rainstorm of September 13, 1996	18

LIST OF TABLES

NO.	TITLE	PAGE
1.	Rainfall Observations Using Different Rain Gauges	09
2.	Rainfall Data (in mm) from Four Rain Gauges	11
3.	Summary Output of WRG Vs ORG	12
4.	Summary Output of WRG Vs SRRG	12
5.	Summary Output of SRRG Vs ORG	13
6.	Analysis of Combined Rainfall Events	16
A-1.	Rainfall Data (in mm) at NIH Campus dur.t. 1996-97	21

ABSTRACT

Rainfall measurement is the core of all hydrological measurements. For automated recording of rainfall data, tipping bucket rain gauges are generally used. It has been reported that the tipping bucket mechanism of such rain gauges frequently malfunctions and gives erroneous data, especially during high intensity rainstorms. Weighing type rain gauges are considered worldwide as accurate and reliable.

Reliable and accurate measurement of rainfall is an essential requirement in hydrological studies. Development and testing of a weighing rain gauge, using components and systems available indigenously, is reported. The rain gauge has a capacity of upto 130mm rainfall before the gauge is emptied through a draining mechanism. With the reported rain gauge, the total amount of rainfall can be measured continuously, and the rainfall intensity can be derived. The rainfall observations from the reported Weighing Rain Gauge (WRG) were compared with that of the other standard rain gauges- SRRG and ORG, at a site in Roorkee (India). The results of the field testing during 1996-1997 are presented in the report.

1.0 INTRODUCTION

Knowledge about the spatial and temporal distribution of precipitation is a crucial requirement whenever one wants to look on the details of any hydrological process in space and time. It is, for instance, ridiculous to apply detailed, distributed hydrologic models without having the matching resolution in the precipitation data. On the other hand, when integrating over the catchment area as with water balance studies or the use of lumped hydrologic models, the spatial distribution is of no importance, and only areal precipitation is needed.

Rainfall totals have long been recorded by mounting a funnel over a graduated collecting vessel. Later developments led to the autographic recorders and the magnetic tape recorders, which counted the number of tips of a collecting bucket during short time intervals. The basic principle of different type of rain gauges is the same, i.e. the water is collected through a catch of some standard diameter and therefrom it is fed to some measuring mechanism. The recording rain gauges are used to collect information on the intensity of rainfall in addition to the amount of rainfall.

Different kinds of measurement errors are associated with the three types of recording gauges being widely used, i.e. chart-recording type, tipping bucket type and weighing rain gauges. For example, in chart-recording type rain gauge, some amount of water is required to uplift the float which is evaporated if there is a gap of longer period between two consecutive rain events, which creates an error in the measurements (WMO, 1982). Secondly, accountability of rainfall is not possible if it occurs during the draining out of water. Although the time period of draining the water may be short, but the error percentage will depend upon the intensity of rainfall (Sevruk, 1987).

The main advantage of tipping bucket gauges is that it has an electronic pulse output and can be recorded at a distance. Its disadvantages are (1) the bucket takes a small but finite time to tip, and during the first half of its motion, the rain is being fed into the compartment already containing the calculated amount of rainfall. This error is appreciable, however, in heavy rainfall, and (2) because

of the discontinuous nature of the record, the instrument is not satisfactory for use in light drizzle or very light rain. The time of beginning and ending of rainfall cannot be determined accurately (WMO, 1994, and Simic and Maksimovic, 1994).

2.0 WEIGHING RAIN GAUGES

In weighing rain gauge, the weight of a collector bucket plus the precipitation accumulating in it is recorded continuously. Thus, all precipitation is recorded as it falls. The gauge element consists of a spring or lever balance with a platform on which a bucket rests. The compression of the spring and weight of water in the bucket are precisely calibrated. The incoming rain caught by the receiver is funneled into the bucket which compresses the spring. The compression of the spring is transmitted to the pen which covers a distance proportional to the depth of water received by the bucket. Belfort's Universal Precipitation Gauges provide a potentiometric output corresponding to the weight of the accumulated rainfall. Weighing rain gauge manufactured by a Swedish firm (InSitu) and an American firm (ETI) measure the weight of accumulated rainfall using load cell, and then precipitation is calculated from the increase in weight. Bakkehol et al. (1985) also reported an automatic precipitation gauge based on vibrating-wire strain gauge for an accumulated precipitation capacity of upto 300mm.

3.0 WRG CONFIGURATION

The WRG is based on a weighing mechanism using strain gauge based load cell. The complete sensor assembly of the instrument is shown in Figure 1. It consists of an outer container of 205mm dia (called the catch dia) and 500mm height and an inner container of 175mm dia and 190mm height. A collector rim of 205 mm dia was used on the outer container from which the water is collected through a funnel into an inner container. With this arrangement, a full collector bucket

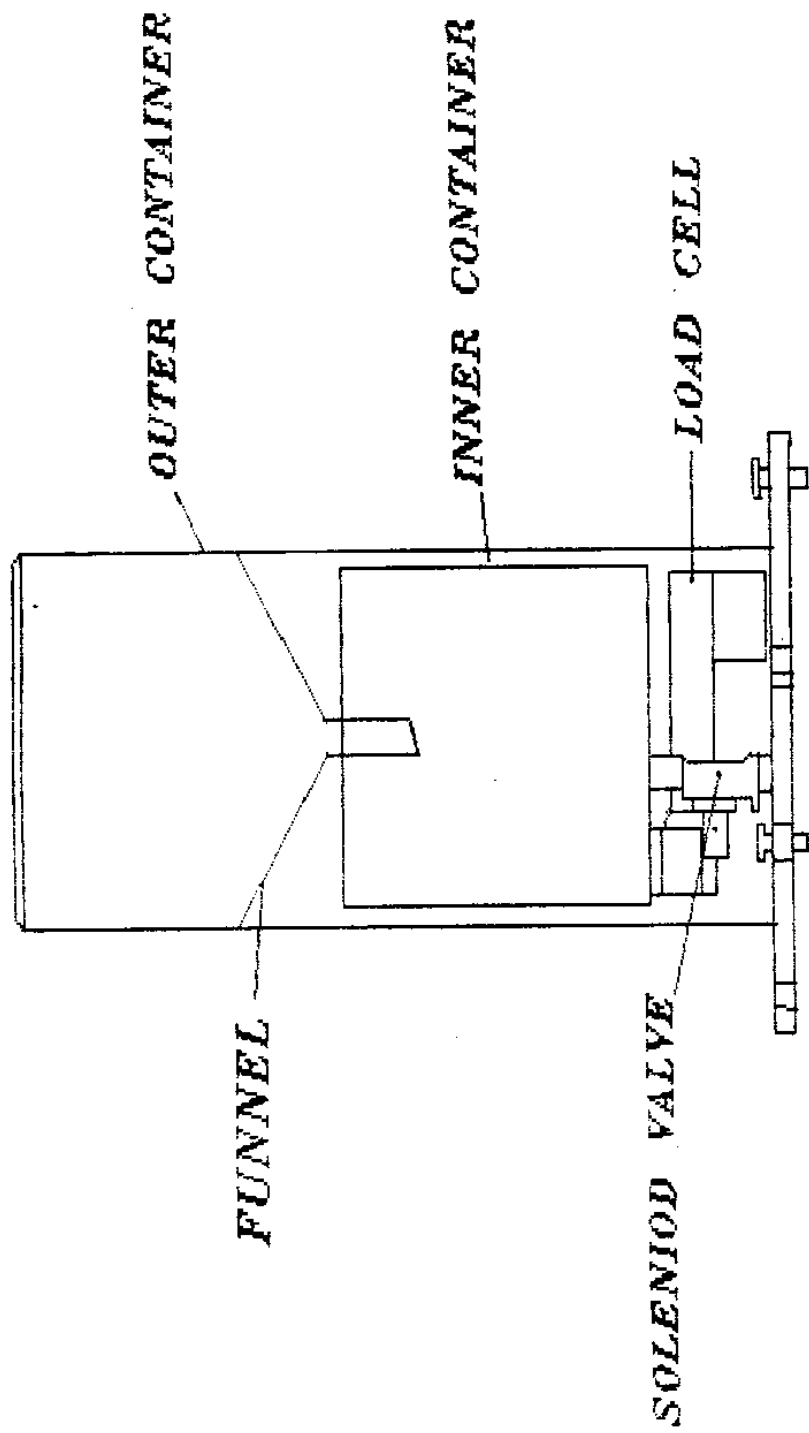

WEIGHING TYPE RAIN GAUGE

Figure 1 PLAN

contains 4.57 litre rainwater which corresponds to 13.85cm of rainfall. The inner container (collector bucket) rests on the load cell and was designed to store water corresponding to 130mm of rainfall before the accumulated rainwater is drained out. The dead weight of the collector bucket was 2Kg approximately and, therefore, a load cell of 10kg capacity was used. With a reported load cell accuracy of 0.03%, the weighing mechanism was designed to measure the rainfall at an accuracy of $\pm 0.2\text{mm}$.

Initially, a commercially available data logger (CR10 of Campbell Scientific Inc., USA) was used with the load cell based sensor for measuring and recording the rainfall data. Extensive laboratory and field tests were carried out with this set up (Goyal and Gupta, 1994). Later, a micro-controller based data logger was designed in-house, using indigenously available components. The design presented in this report is that of the indigenously designed data logger, and is shown in Figure 2.

The reported system is based around a micro-controller (Intel 80C31) along with other required peripheral chips, such as 8255 Programmable Peripheral Interface (PPI), MC146818 Real Time Clock (RTC), ICM 7135 12-bit Analogue-to-Digital Converter (ADC), a few digital ICs and signal conditioning circuitry. A 4x4 key matrix and a 20x4 intelligent LCD display were used for programming and display purposes, respectively.

The measured data was stored in an on-board 128kB Random Access Memory (RAM) module (four 62C256 RAM chips, each of 32Kx 8-bit). An 146818 RAM (8Kx8-bit) with RTC and battery backup was also used for storing the calibration constants and getting the real time and date, with memory retention facility. A monitor programme (in 8031's assembly language) to control the complete operation was stored in a 32Kb EPROM (27C256). The micro-controller controlled the sampling and data storage intervals, operation of the solenoid valve, and storage of the measured data along with the date and time in the memory module.

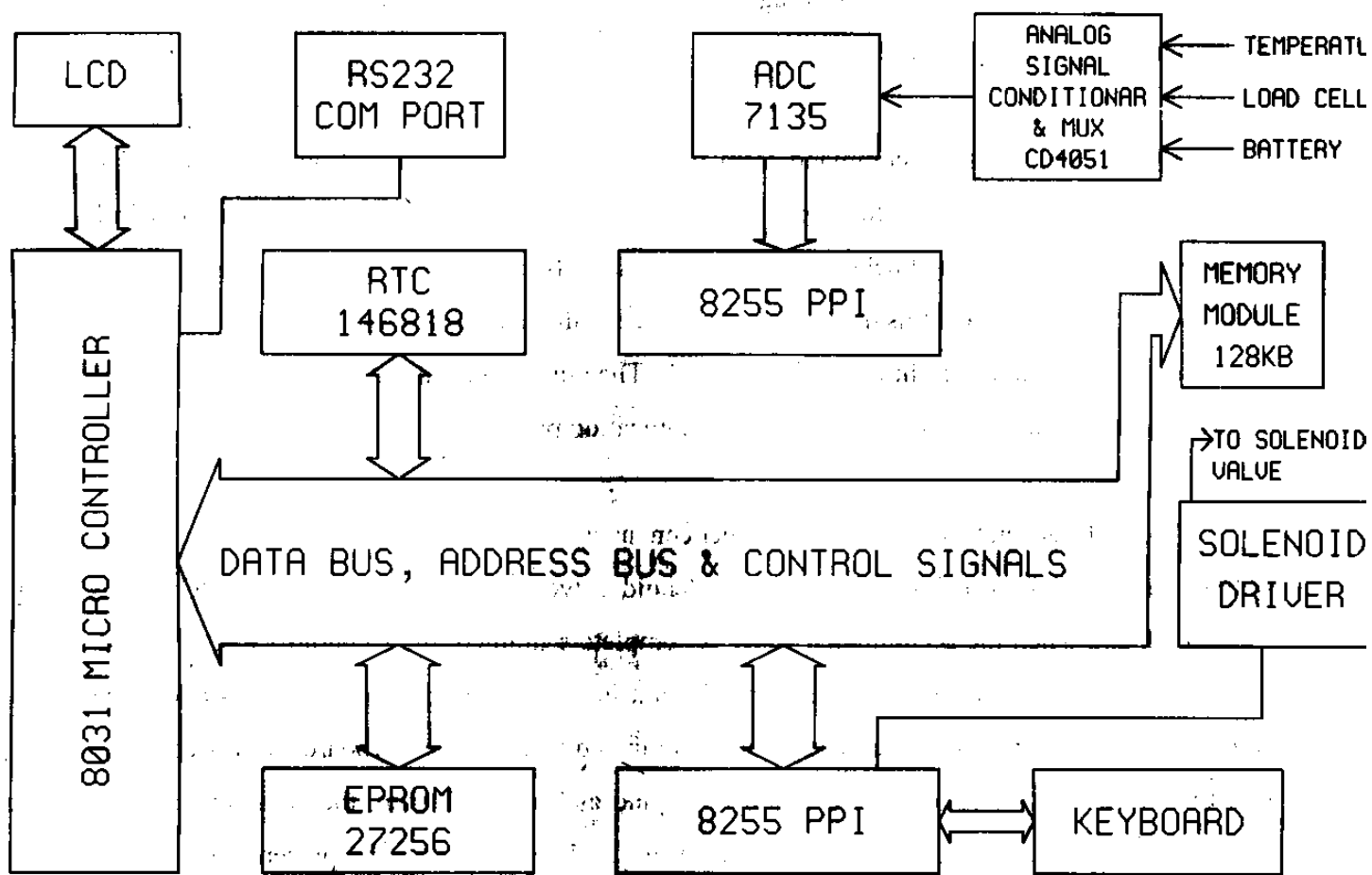

Figure BLOCK DIAGRAM : RAINFALL MEASUREMENT USING WRG

4.0 SOFTWARE FEATURES

The WRG was operated using instructions as shown in the flow chart (Fig 3). The process starts by initializing the system's peripherals. During the calibration process, date and time are fed in the data logger, and sampling and storage intervals and drain level are programmed. Also, a code for station identification is supplied.

On detecting a 'start' command from the keyboard, data (weight) from the load cell is obtained through the Analogue-to-Digital Converter (ADC) on completing the sampling interval. Dead weight of the weighing bucket is now eliminated as offset during the calibration process. The ADC is then again read, and this data is then multiplied with the calibration constant ($=1/\text{catch area}$) to convert the measured weight into mm of rainfall. The rainfall data along with date and time, are stored in memory module through a serial communication port.

When the accumulated water in the inner container reaches a volume corresponding to a user defined rainfall depth (i.e. 'drain level'), the solenoid valve is activated. Again the ADC data is monitored, and when the accumulated water is completely drained, the solenoid valve is closed. Operation of the solenoid valve at any time instant is also possible through a key-stroke. The complete system is halted on receiving a 'stop' command through the keyboard. In this case, the system is reset and waits for the keyboard command as 'start' and, then, the complete cycle is repeated. The system starts collecting data from the load cell and adds the present value to the previous reading. The stored data can be viewed on the LCD display whenever desired; at all other times the display is disabled to save power (Fig. 4).

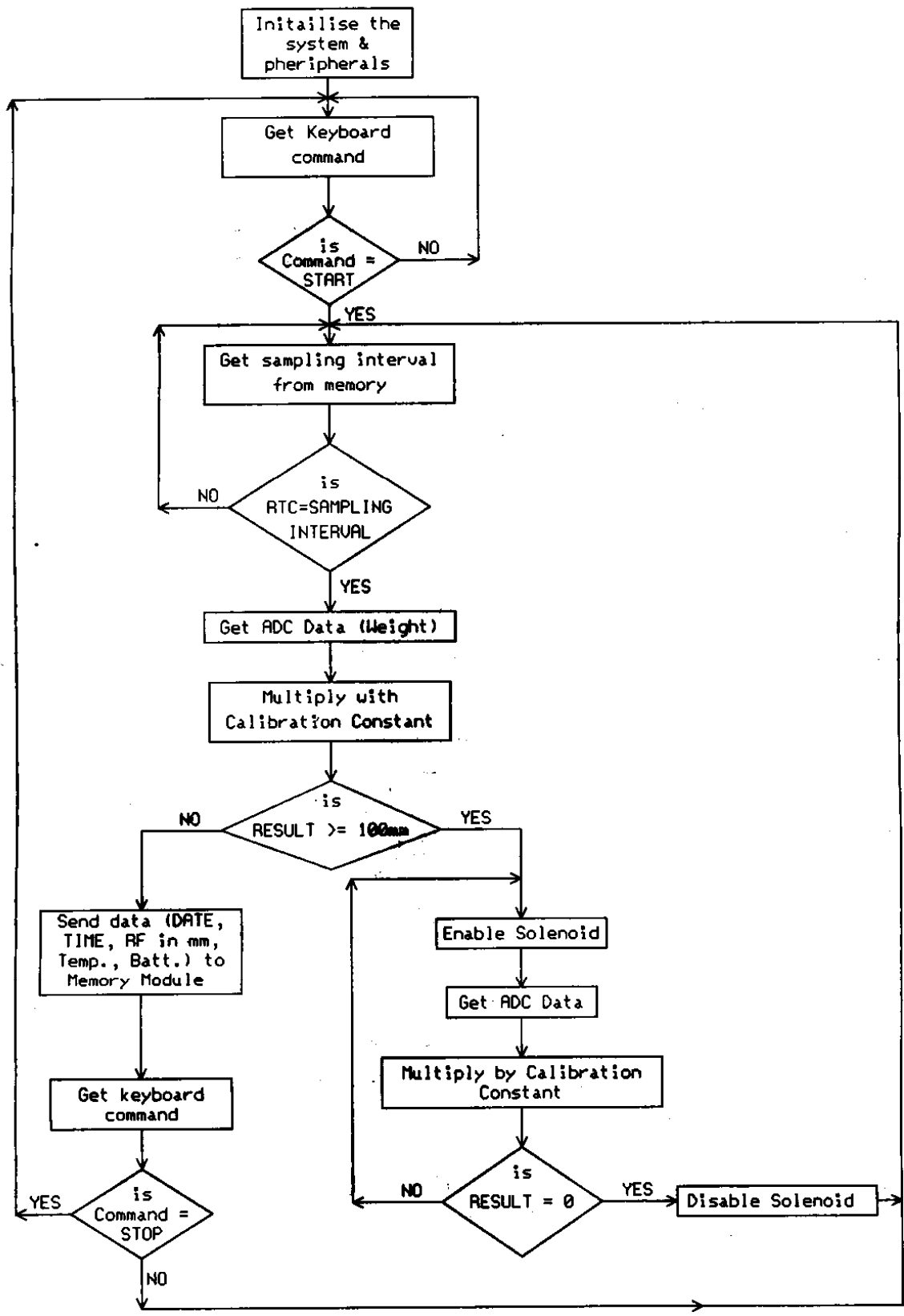

Figure 3

FLOW CHART RAINFALL MEASUREMENT USING WRG

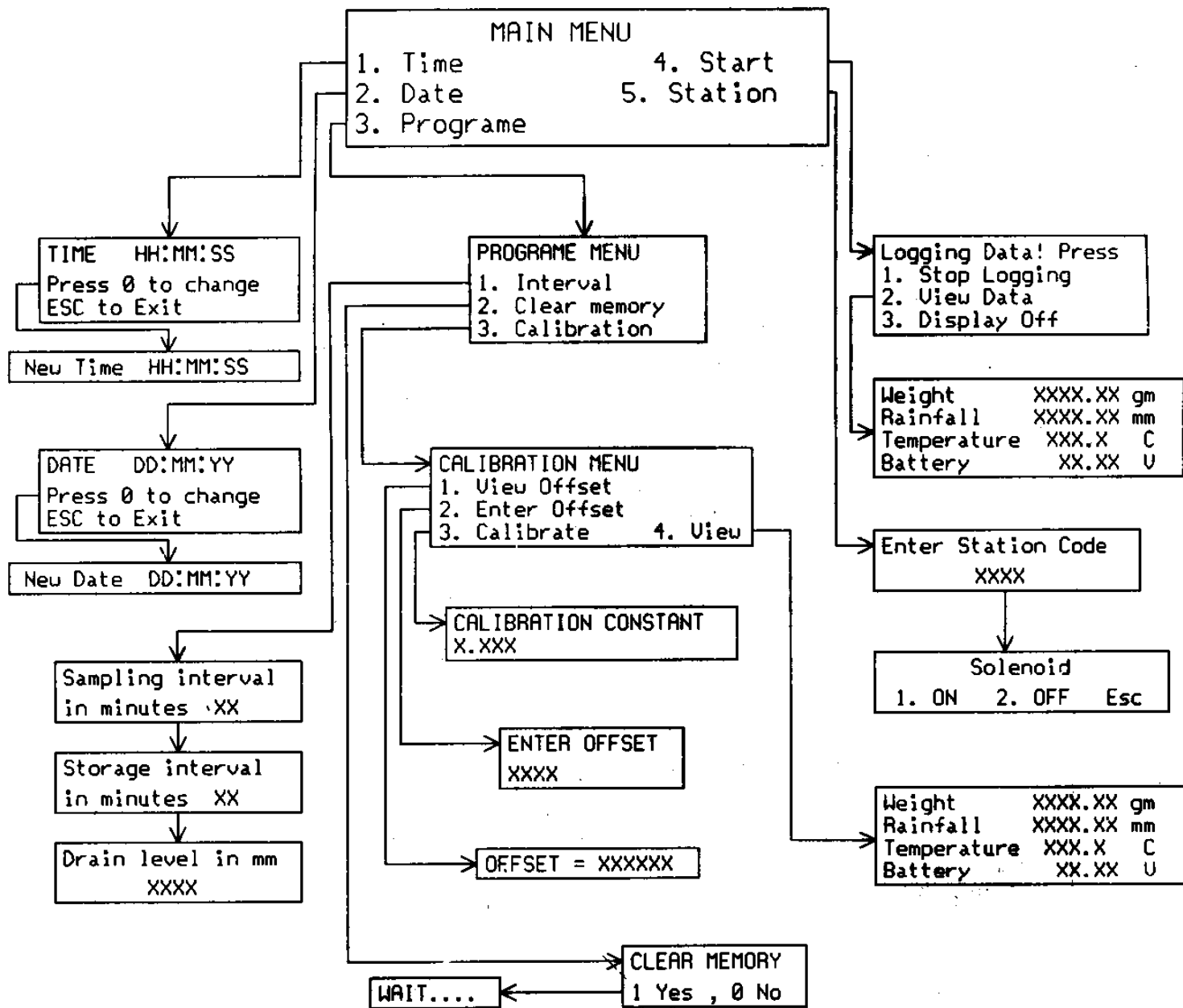

Figure 4 SCHEMATIC OF DATA LOGGER OPERATION

5.0 RESULTS AND DISCUSION

The instrument was tested in the Institute's campus (Lat. 29°45'N-30°8'N; Long. 77°14'-77°57'; Elevation 270m above msl) during June-October, 1996. Measured rainfall values from WRG were compared with those of Ordinary non-recording Rain Gauge (ORG), Self Recording Rain Gauge (SRRG), and Tipping Bucket Rain Gauge (TBRG) available in the Institute's campus. Daily totals of the rainfall values from the four rain gauges are presented in Table 1.

TABLE 1. Rainfall Observations Using Different Rain Gauges at NIH Campus

S No	Date (08:30 hrs)	WRG	ORG	WRG- ORG	TB	WRG- TB	TB- ORG	SRRG	WRG- SRRG	SRRG- ORG
1	25/6/96	3.3	3.1	0.2	3.048	0.252	-0.052			
2	27/6/96	23.78	20.6	3.18	21.336	2.444	0.736	21	2.78	0.4
3	29/6/96	0.55	0.5	0.05	1.016	-0.466	0.516			
4	30/6/96	13.76	14.2	-0.44	14.224	-0.464	0.024	13.35	0.41	-0.85
5	5/7/96	31.25	32.1	-0.85	34.544	-3.294	2.444	33.6	-2.35	1.5
6	10/7/96	15.67	15.2	0.47	16.256	-0.586	1.056	14.5	1.17	-0.7
7	11/7/96	21.39	21.4	-0.01	23.368	-1.978	1.968	21.25	0.14	-0.15
8	26/7/96	10.47	10.4	0.07	12.192	-1.722	1.792		-0.23	0.3
9	18/8/96	1	1	0	1.016	-0.016	0.016			
10	19/8/96	116.32	121.4	-5.08	117.856	-1.536	-3.544		-2.18	-2.9
11	20/8/96	9.65	9	0.65	10.16	-0.51	1.16		0.45	0.2
12	21/8/96	29.79	27.4	2.39	31.496	-1.706	4.096		0.79	1.6
13	23/8/96	7.05	7	0.05	8.128	-1.078	1.128			
14	24/8/96	47.1	43.6	3.5	47.752	-0.652	4.152		2.6	0.9
15	4/9/96	23.63	24	-0.37	25.4	-1.77	1.4		-1.17	0.8
16	5/9/96	8.81	6	2.81	8.128	0.682	2.128			
17	8/9/96	1.69	1.5	0.19	3.048	-1.358	1.548			
18	10/9/96	32.11	35.1	-3.0	33.267	-49.17	45.68		-7.39	3.9
19	11/9/96	7.77	5.6	2.17	6.096	1.674	0.496			
20	14/9/96	25.97	23.3	2.67	26.416	-0.446	3.116	20.5	5.47	-2.8
21	16/9/96	40.96	37	3.96	39.624	1.336	2.624	30.5	10.46	-6.5
22	19/9/96	23.68	21.8	1.88	24.384	-0.704	2.584		3.38	-1.5
23	4/10/96	18.22	16	2.22	18.288	-0.068	2.288		3.72	-1.5
24	3/9/96	35.13	4.5	30.63	34.24	22.814	55.444			
25	9/9/96	23.07	123.7	-100.63						
26	28/8/96	7.09	6.2	0.89						
27	2/9/96	25.33	32	-6.67						

For evaluation purposes, the WRG was operated at different storage intervals- 5 min, 15 min, and 30 min, but the analysis reported here has been done on 30-minute data. The data shown in this study were not corrected for any losses. SRRG available at the location did not function for some of the events. For comparison purposes, 16 events were selected (Table 2) for which data from all the four rain gauges were available. Out of 16 events, 11 events were with rainfall more than 20mm; 15 events with rainfall more than 10mm. A single event (on August 19, 1996) recorded more than 100mm rainfall in 24 hrs. Total rainfall for the recording period for different rain gauges was included in the Table to have a qualitative idea of the comparative performances of the four rain gauges.

Since non-recording rain gauge (ORG) has no moving parts and collects the total rain poured during a defined time interval (e.g. a day), thus minimising the chances of error in measurement, it is usually considered the standard gauge for comparing measurements from the other rain gauges (WMO, 1994). Data recorded by the WRG was compared with those recorded by the ORG, SRRG, and Tipping Bucket rain gauges. Comparative performances of SRRG and TB gauges were also evaluated with respect to the ORG. Percent error in the data observed by different gauges is calculated as:

$$\% \text{ Error in "X" gauge} = 100 \frac{\text{"X" gauge} - \text{ORG}}{\text{ORG}}$$

Regression analysis was performed between rainfall values of WRG and ORG rain gauges. A correlation coefficient of 0.99 was obtained, with standard error of 1.958 (Table 3). Similarly, correlation coefficient of 0.98 was obtained for regression between WRG and SRRG values (Table 4). Also, in order to compare the performances of ORG and SRRG gauges, a regression analysis was performed between SRRG and ORG values, and a correlation coefficient of 0.99 was obtained (Table 5). Comparative performance of the WRG with respect to the standard ORG and SRRG is shown in Figures 5 and 6, respectively.

TABLE 2. Rainfall Data (in mm) from four Rain Gauges at NIH Campus

Date (08:30 hrs)	WRG ORG	WRG- ORG	% Error (WRG Vs ORG)	Tipping Bucket	WRG- TB	% Error (WRG Vs TB)	TB-ORG	% Error (TB Vs ORG)	SRRG	WRG- SRRG	% Error (WRG Vs SRRG)	SRRG -ORG	% Error (SRRG Vs ORG)
27/06/96	23.78	20.6	3.18	21.336	2.444	11.45481	0.736	3.5728	21	2.78	13.2380	0.4	1.94174
30/06/96	13.76	14.2	-0.44	14.224	-0.464	-3.262092	0.024	0.1690	13.35	0.41	3.07116	-0.85	-5.98591
05/07/96	31.25	32.1	-0.85	34.544	-3.294	-9.535664	2.444	7.6137	33.6	-2.35	-6.99404	1.5	4.67289
10/07/96	15.67	15.2	0.47	16.256	-0.586	-3.604822	1.056	6.9473	14.5	1.17	8.06896	-0.7	-4.60526
11/07/96	21.39	21.4	-0.01	23.368	-1.978	-8.464566	1.968	9.1962	21.25	0.14	0.65882	-0.15	-0.70093
26/07/96	10.47	10.4	0.07	12.192	-1.722	-14.12401	1.792	17.230	10.7	-0.23	-2.14953	0.3	2.88461
19/08/96	116.32	121.4	-5.08	117.856	-1.536	-1.303285	-3.544	-2.9192	118.5	-2.18	-1.83966	-2.9	-2.38879
20/08/96	9.65	9	0.65	10.16	-0.51	-5.019685	1.16	12.888	9.2	0.45	4.89130	0.2	2.22222
21/08/96	29.79	27.4	2.39	31.496	-1.706	-5.416560	4.096	14.948	29	0.79	2.72413	1.6	5.83941
24/08/96	47.1	43.6	3.5	47.752	-0.652	-1.365387	4.152	9.5229	44.5	2.6	5.84269	0.9	2.06422
04/09/96	23.63	24	-0.37	25.4	-1.77	-6.968503	1.4	5.8333	24.8	-1.17	-4.71774	0.8	3.33333
10/09/96	32.11	35.6	-3.49	81.28	-49.17	-60.49458	45.68	128.31	39.5	-7.39	-18.7088	3.9	10.9550
14/09/96	25.97	23.3	2.67	26.416	-0.446	-1.688370	3.116	13.373	20.5	5.47	26.6829	-2.8	-12.0171
16/09/96	40.96	37	3.96	39.624	1.336	3.371693	2.624	7.0918	30.5	10.46	34.2950	-6.5	-17.5675
19/09/96	23.68	21.8	1.88	8.6238	-0.704	-2.887139	2.584	11.853	20.3	3.38	16.6502	-1.5	-6.88073
04/10/96	18.22	16	2.22	13.875	-0.068	-0.371828	2.288	14.3	14.5	3.72	25.6551	-1.5	-9.375
Total	483.75	473		544.576		-11.69%			465.7		3.87%		-1.54%

TABLE 3. SUMMARY OUTPUT OF WRG Vs ORG

<i>Regression Statistics</i>					
Multiple R					0.996513
R Square					0.993039
Adjusted R Square					0.992542
Standard Error					2.171219
Observations					16

<i>ANOVA</i>					
	<i>df</i>	<i>SS</i>	<i>MS</i>	<i>F</i>	<i>Significance F</i>
Regression	1	9415.834	9415.83	1997.33	1.66325E-16
Residual	14	65.99872	4.71419		
Total	15	9481.832			

	<i>Coefficients</i>	<i>Standard Error</i>	<i>T Stat</i>	<i>P-value</i>	<i>Lower 95%</i>
Intercept	2.1427	0.8305	2.5800	0.0218	0.3615
X Variable	0.9502	0.0212	44.6915	1.66325E	0.9046

TABLE 4. SUMMARY OUTPUT OF WRG Vs SRRG

<i>Regression Statistics</i>					
Multiple R					0.988807
R Square					0.977741
Adjusted R Square					0.976151
Standard Error					3.882703
Observations					16

<i>ANOVA</i>					
	<i>Df</i>	<i>SS</i>	<i>MS</i>	<i>F</i>	<i>Significance F</i>
Regression	1	9270.77	9270.77	614.961	5.72703E-13
Residual	14	211.055	15.0753		
Total	15	9481.83			

	<i>Coefficients</i>	<i>Standard Error</i>	<i>t Stat</i>	<i>P-value</i>	<i>Lower 95%</i>
Intercept	2.3014	1.4869	1.5477	0.143979	-0.8877
X Variable	0.9596	0.0386	24.7984	5.7270E	0.8766

TABLE 5. SUMMARY OUTPUT OF SRRG Vs ORG

<i>Regression Statistics</i>	
Multiple R	0.996121
R Square	0.992258
Adjusted R Square	0.991705
Standard Error	2.359332
Observations	16

ANOVA					
	<i>df</i>	<i>SS</i>	<i>MS</i>	<i>F</i>	<i>Significance F</i>
Regression	1	9988.044	9988.044	1794.329	3.50394E-16
Residual	14	77.93027	5.566448		
Total	15	10065.97			

	<i>Coefficients</i>	<i>Standard Error</i>	<i>t Stat</i>	<i>P-value</i>	<i>Lower 95%</i>	<i>Upper 95%</i>
Intercept	0.1736	0.9024	0.1924	0.8501	-1.7619	2.1092
X Variable	0.9786	0.0231	42.3595	3.5039E	0.9291	1.0282

Some of the observations specific to the four rain gauges, as reported in Table 2, are discussed in the following paragraphs:

On September 10, 1996 there was some problem with the TB rain gauge. TB recorded an exceptionally high catch (possibly due to malfunctioning); % error w.r.t. ORG was 128.3%. Except in 5 cases, % error w.r.t. ORG was less than 10%. TBRG performed reasonably well during other high rainfall events

Data shaded in the SRRG column was taken from a nearby SRRG station. On September 16, 1996 there was some problem with the SRRG. The SRRG recorded a low catch; % error w.r.t. ORG was -17.57%. Except in 3 cases, % error of SRRG w.r.t. ORG was less than 10%. During high intensity events, it is difficult to identify individual events on SRRG recordings.

Figure 5 Testing of WRG at NIH Campus (1996)

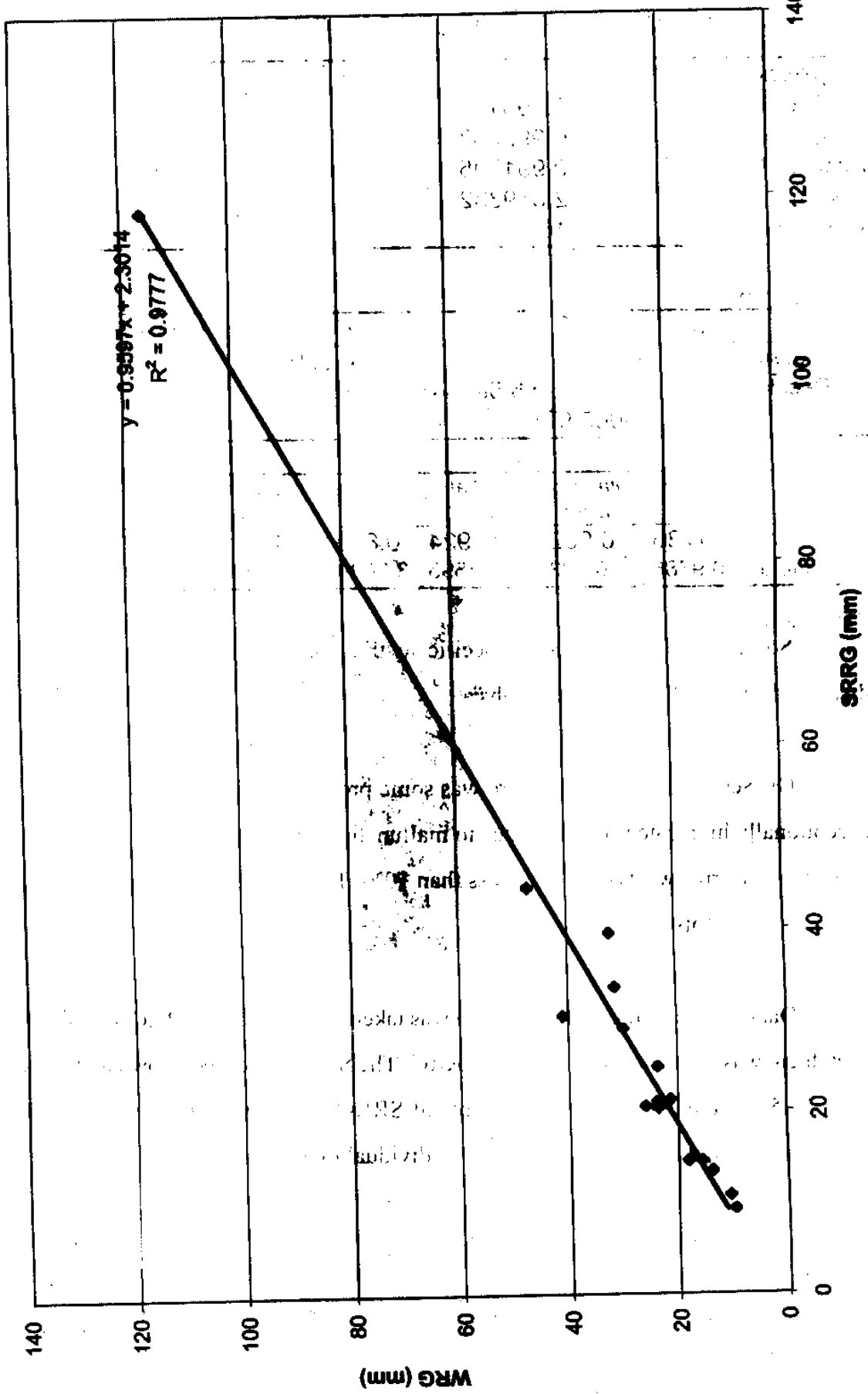
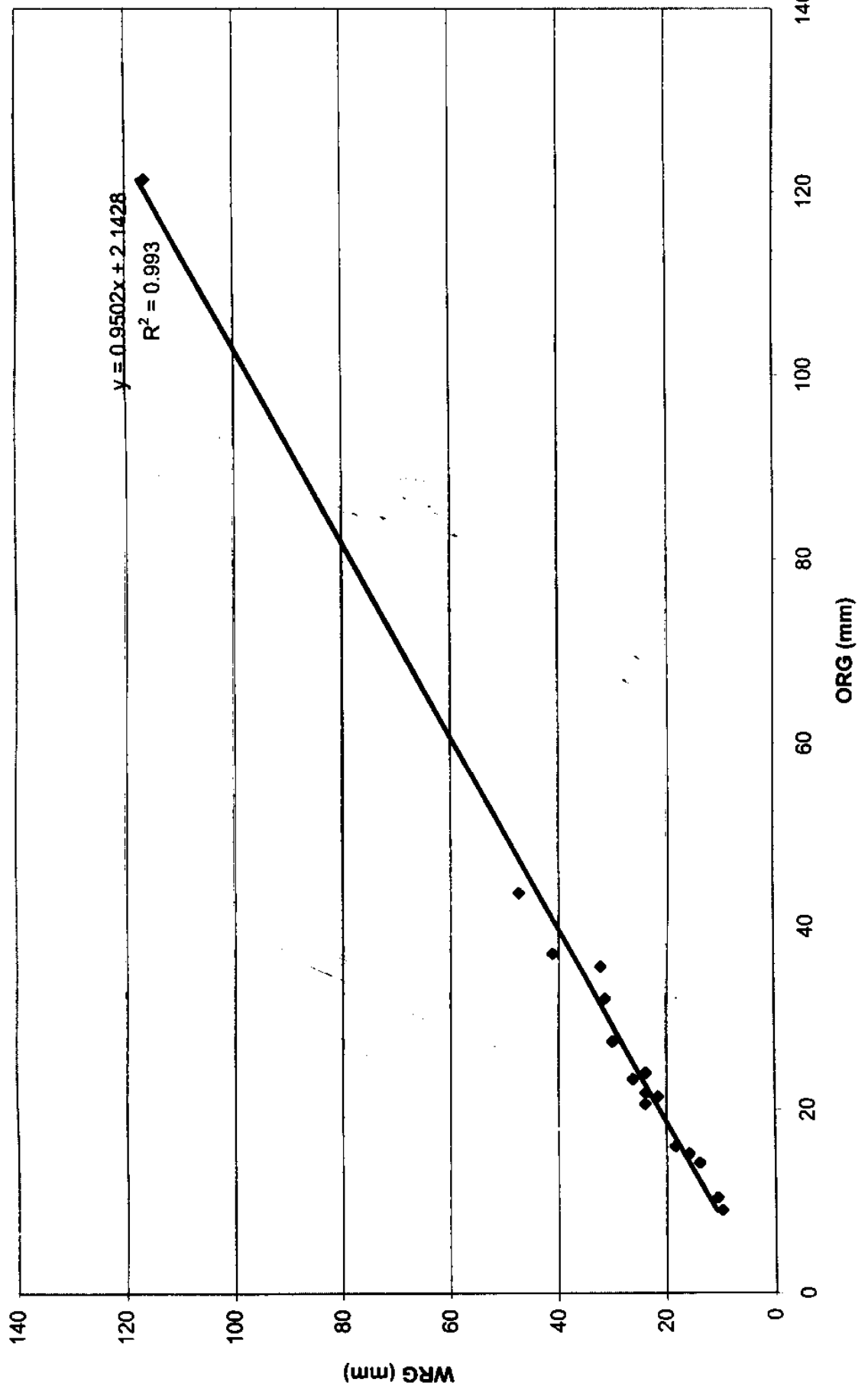

Figure 6 Testing of WRG at NIH Campus (1996)



On September 9, 1996 there was some problem with the WRG. It had to be drained in between recordings (on September 8 at 6.05 P.M.) and, as a result, WRG reported 23.07mm rainfall as compared to 123.7mm and 121.6mm on ORG and SRRG, respectively. This event was subsequently eliminated from the Table for further analysis. A lag is observed in WRG recordings as compared to SRRG values (Table 2). This was also evident when the rainfall values of WRG from two or more successive days are combined and compared with those of the corresponding ORG values. Percent error in these cases is substantially lower than the corresponding error when the events are considered individually (Table 6).

TABLE 6. Analysis of Combined Rainfall Events

Dates	Rainfall (WRG)	Rainfall (ORG)	WRG- ORG	% Error (WRG Vs ORG)
June 29+30	14.31	14.7	-0.39	-2.6
July 10+11	37.06	36.6	0.46	1.2
August 19+20+21	155.76	157.8	-2.04	-1.3
August 23+24	54.15	50.6	3.55	7.0
September 4+5	32.44	30.0	2.44	8.1
September 10+11	39.88	41.2	-1.32	-3.2

On July 10, 1996 and September 13, 1996, rainfall of 15.67mm and 25.97mm, respectively, were recorded using the WRG. The rainfall measured by the standard ORG for these two rainstorms were 15.2mm and 23.3mm, respectively, whereas rainfall measured by SRRG were 14.5mm and 20.5mm, respectively. The results for these two rainstorms for WRG and SRRG rain gauges are shown in Figure 7.

During 1400 hrs to 1500 hrs on July 9, 1996, WRG caught 12.89 mm of rain whereas SRRG caught 12.0 mm during 1245 hrs to 1400 hrs on the same day. It appears that the accumulation of

RAINSTORM OF JULY 11, 1996

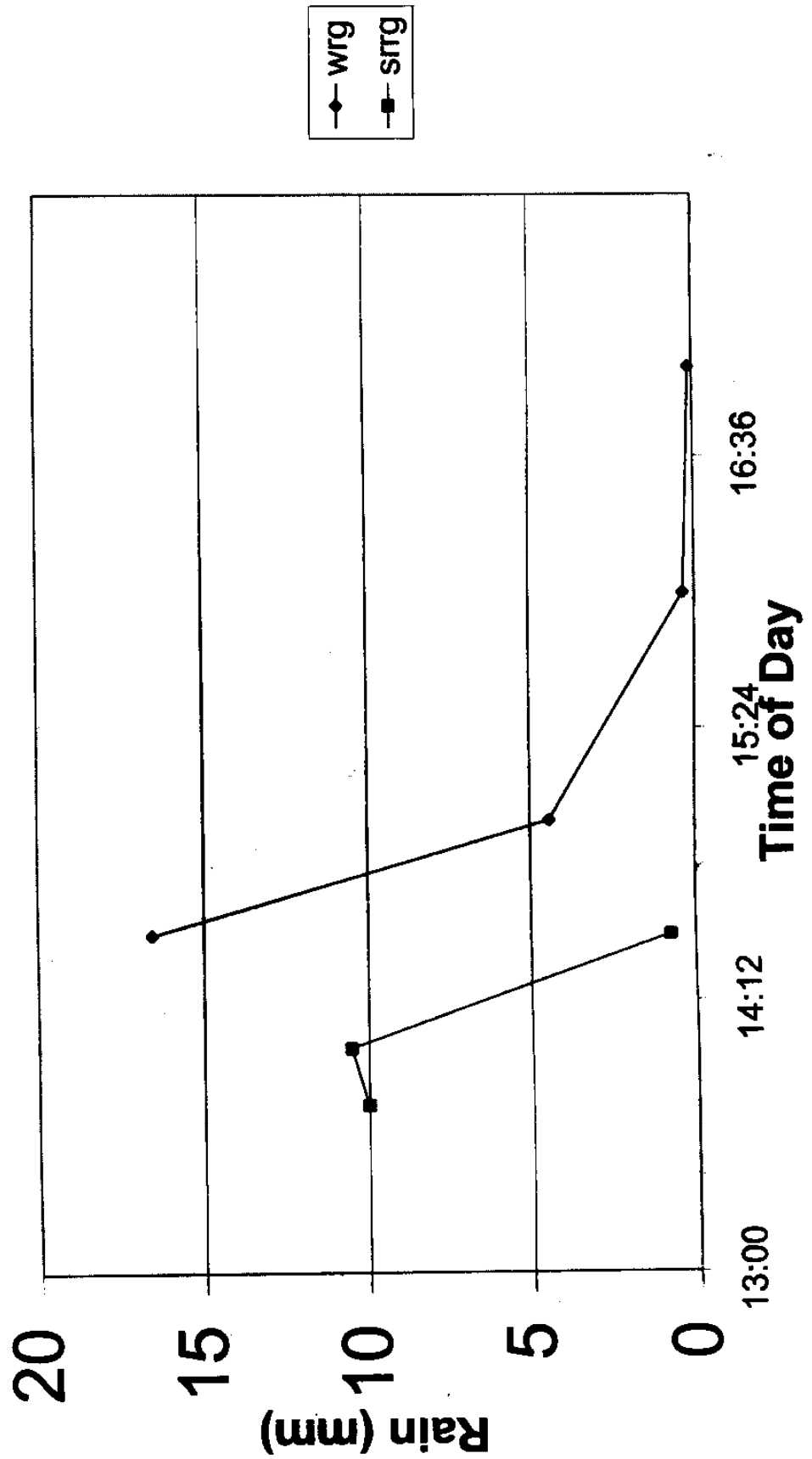

Figure 7(a) 17

RAINSTORM OF SEPT 13, 1996

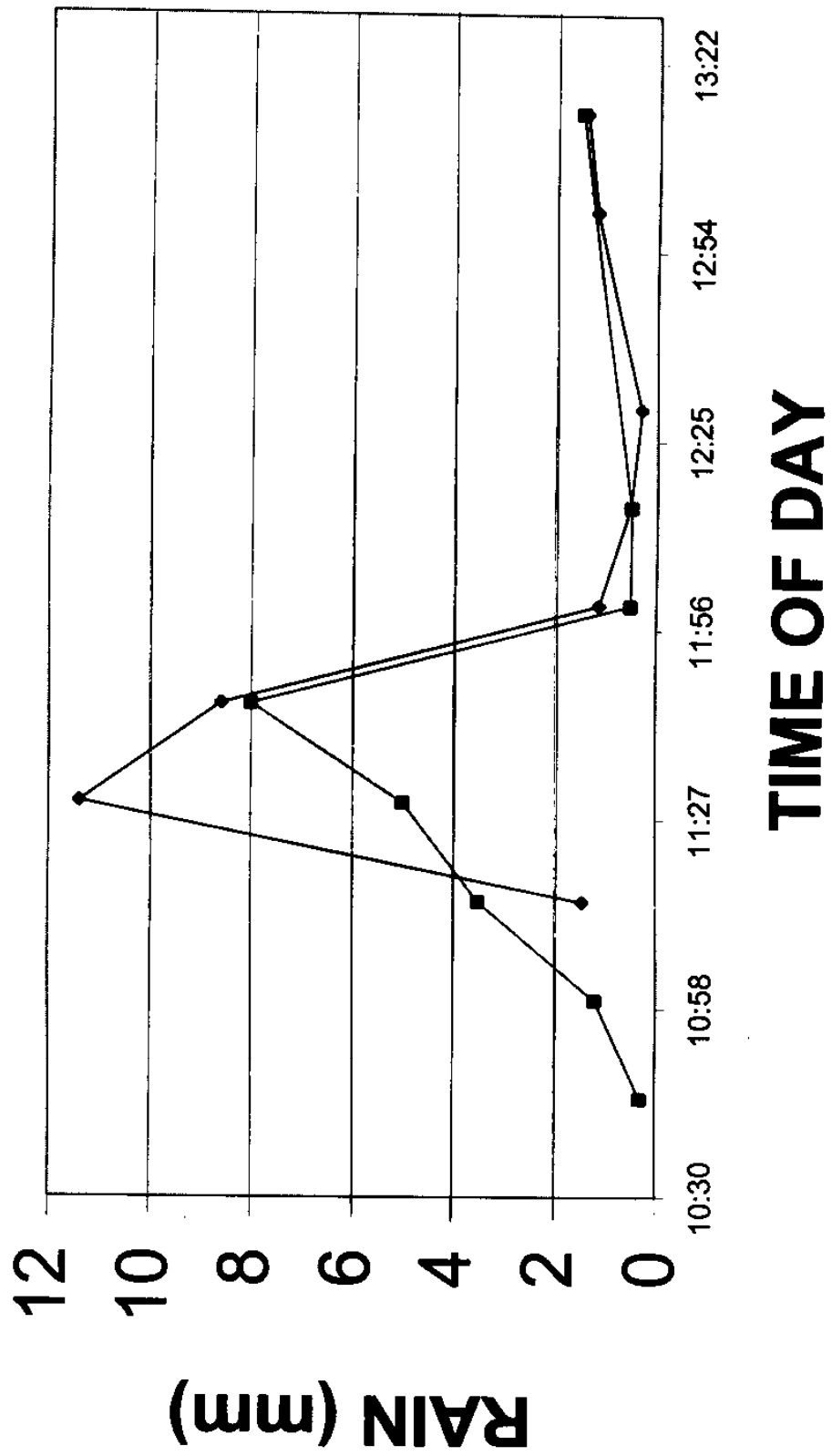

Figure 7(b)

rainwater was delayed in the case of WRG. Similarly, on September 13, 1996, WRG recorded 1.44mm rain as compared to 5.0mm of SRRG until 1115 hrs. During next 30 minutes, WRG recorded 11.39mm as compared to 5.0mm of SRRG. This delay in the accumulation in case of WRG may be a result of either slow response of its electronics or some mechanical problem with the catch of the WRG. When the total rainfall during the reported period (Table 2) is compared, the WRG catch is off by 2.27% from ORG, -11.69% from TB, and 3.87% from SRRG, respectively, which is a reasonably good performance. The total catch by the SRRG itself was off from that of the ORG by -1.54%.

6.0 CONCLUDING REMARKS

A weighing type rain gauge with electronic data logging circuitry was developed and tested at NIH Campus in Roorkee (India). The field-testing confirmed a resolution of 0.2mm of rainfall when compared with standard SRRG type rain gauges used in the country. The complete unit is battery operated and is suitable for extended field operations. With the reported rain gauge, the total amount of rainfall can be measured continuously, and the rainfall intensity derived. In view of the shortcomings discussed above, further field testing is necessary to establish the efficacy of WRG over the conventional rain gauges.

REFERENCES

- Bakkehol, S, Olen, K and Forland, E J, 1985. An automatic precipitation gauge based on vibrating wire strain gauge, *Nordic Hydrology*, 16, 193-202.
- Goyal, V C and Gupta, Sandeep, 1994. Development of a weighing type rain gauge, *National Workshop on Advances in Hydrological Instrumentation*, Oct 25-26, 1994, Roorkee.
- Sevruk, B, 1987. Point precipitation measurements: Why are they not corrected?, *Water for the future, Hydrology in perspective, Proc. of Rome Symposium, IAHS Publication No.164.*
- Simic, M and Maksimovic, Z, 1994. Effect of the siphon control on the dynamic characteristics of a tipping bucket rain gauge, *Hydrological Sciences JI.*, 39, 1, 35-46.

WMO, 1982. Methods of correction for systematic error in point precipitation measurement for operational use (B Sevruk), Operational Hydrology Report No. 21, WMO-No. 589, Geneva.

WMO, 1994. Guide to Hydrological Practices, WMO No. 168, Geneva.

TABLE A-1. Rainfall Data (in mm) at NIH Campus during 1996-97

Date	Time	WRG	Daily Total	Date	ORG	Date	Time	SRRG	Daily Total	Date	Time	Tipping bucket	Daily Total
24/06/96	12:30	0.38											
24/06/96	14:00	0.1											
24/06/96	14:30	1.59								24/6/96	14:30	0.4	
24/06/96	15:00	0.22									16:30	0.2	
24/06/96	17:00	1.01	3.3	25/6/96	3.1								0.6
27/06/96	3:30	0.1				27/6/96	6:00	0.5		27/6/96	6:30	0.4	
27/06/96	6:00	0.21				27/6/96	6:15	0.5		27/6/96	7:00	1	
27/06/96	6:30	2.68				27/6/96	6:30	3.5		27/6/96	7:30	2.2	
27/06/96	7:00	6				27/6/96	6:45	6.5		27/6/96	8:00	0.4	
27/06/96	7:30	14.79				27/6/96	7:00	5.5		27/6/96	8:30	0.2	
						27/6/96	7:15	1.7		27/6/96	9:00	0.4	
						27/6/96	7:30	0.8		27/6/96	9:30	0.4	
						27/6/96	7:45	0.9					
						27/6/96	8:00	0.1					
						27/6/96	8:15	0.5					
			23.78	27/6/96	20.6	27/6/96	8:30	0.5	21	27/6/96			4.2
29/06/96	5:30	0.16											
29/06/96	6:00	0.16											
29/06/96	6:30	0.23	0.55	29/6/96	0.5					29/6/96	6:00	0.2	0.2
30/06/96	3:30	0.58				30/6/96	1:15	0.5		30/6/96	4:00	0.2	
30/06/96	4:00	0.83				30/6/96	2:00	1		30/6/96	4:30	0.6	
30/06/96	4:30	0.3				30/6/96	3:00	4		30/6/96	5:00	1.2	
30/06/96	5:00	6.83				30/6/96	3:30	3.7		30/6/96	5:30	0.2	
30/06/96	5:30	0.76				30/6/96	4:00	1.2		30/6/96	6:00	0.2	
30/06/96	6:00	1.27				30/6/96	4:30	1.75		30/6/96	6:30	0.4	
30/06/96	6:30	2.54				30/6/96	5:00	0.8					
30/06/96	7:00	0.14				30/6/96	6:00	0.4					
30/06/96	7:30	0.28											
30/06/96	8:00	0.12											
30/06/96	8:30	0.11	13.76	30/6/96	14.2				13.35				2.8
04/07/96	10:30	11.99				4/7/96	9:45	8					
04/07/96	11:00	0.87				4/7/96	10:00	4		4/7/96	10:00	1.2	
04/07/96	12:00	0.77				4/7/96	10:15	0.9		4/7/96	10:30	1.6	
05/07/96	4:00	0.13				4/7/96	11:15	0.5		4/7/96	12:00	0.2	
05/07/96	4:30	6.3				5/7/96	3:00	0.2		5/7/96	4:30	3.8	
05/07/96	5:00	11.19				5/7/96	3:45	6.3					
			31.25	5/7/96	32.1	5/7/96	4:00	13.7	33.6				6.8
09/07/96	14:00	5.76				9/7/96	12:45	1.5					
09/07/96	14:30	5.95				9/7/96	13:00	1.75					
09/07/96	15:00	1.18				9/7/96	13:15	5.75		9/7/96	13:30	0.6	
10/07/96	1:00	2.31				9/7/96	13:30	1		9/7/96	14:00	1.4	
10/07/96	6:30	0.14				9/7/96	13:45	1.5		9/7/96	14:30	0.6	

Date	Time	WRG	Daily Total	Date	ORG	Date	Time	SRRG	Daily Total	Date	Time	Tipping bucket	Daily Total
10/07/96	7:00	0.16				9/7/96	14:00	0.5		10/7/96	1:00	0.6	
10/07/96	7:30	0.17				10/7/96	0:15	1.5					
			15.67	10/7/96	15.2	10/7/96	0:30	1	14.5				3.2
10/07/96	14:30	16.55				10/7/96	13:45	10		10/7/96	14:00	0.6	
10/07/96	15:00	4.38				10/7/96	14:00	10.5		10/7/96	14:30	3.8	
10/07/96	16:00	0.34				10/7/96	14:30	0.75		10/7/96	15:00	0.2	
10/07/96	17:00	0.12	21.39	11/7/96	21.4				21.25				4.6
25/07/96	16:00	0.13								25/7/96	17:00	2.4	
25/07/96	16:05	1.52											
25/07/96	16:10	6.37											
25/07/96	16:15	2.28											
25/07/96	18:05	0.17	10.47	26/7/96	10.4								2.4
17/08/96	18:00	0.59								17/8/96	19:00	0.2	
17/08/96	18:30	0.3											
17/08/96	19:00	0.11	1	18/8/96	1								0.2
18/08/96	22:00	0.41								18/8/96	22:30	1.8	
18/08/96	22:30	18.46								18/8/96	23:00	6.2	
18/08/96	23:00	26.68								18/8/96	23:30	5	
18/08/96	23:30	61.29								19/8/96	0:00	4.8	
19/08/96	0:00	4.9								19/8/96	0:30	4.2	
19/08/96	0:30	3.51								19/8/96	1:00	1.2	
19/08/96	1:00	0.62											
19/08/96	1:30	0.45	116.32	19/8/96	121.4								23.2
20/08/96	6:00	0.52								20/8/96	6:00	0.2	
20/08/96	6:15	1.43								20/8/96	6:30	0.8	
20/08/96	6:30	1.83								20/8/96	7:00	0.6	
20/08/96	6:45	1.5								20/8/96	8:00	0.2	
20/08/96	7:00	1.35								20/8/96	8:30	0.2	
20/08/96	7:15	1.28											
20/08/96	7:30	0.5											
20/08/96	8:00	0.39											
20/08/96	8:15	0.39											
20/08/96	8:30	0.46	9.65	20/8/96	9								2
20/08/96	9:15	0.4											
20/08/96	9:30	0.91								20/8/96	9:30	0.4	
20/08/96	9:45	0.98									10:00	0.6	
20/08/96	10:15	4.83									10:30	0.6	
20/08/96	10:30	0.46									11:30	0.2	
20/08/96	11:15	0.53									12:00	1.4	
20/08/96	11:30	0.64									12:30	1.2	
20/08/96	11:45	3.71									13:00	0.4	
20/08/96	12:00	4.38									13:30	0.2	
20/08/96	12:15	2.84									23:00	0.2	
20/08/96	12:30	1.87								21/8/96	4:00	1	
20/08/96	12:45	1.95											
20/08/96	13:00	0.53											

Date	Time	WRG	Daily Total	Date	ORG	Date	Time	SRRG	Daily Total	Date	Time	Tipping bucket	Daily Total
20/08/96	14:15	0.34											
21/08/96	2:45	0.46											
21/08/96	4:00	4.96	29.79	21/8/96	27.4								6.2
23/08/96	5:30	0.32								23/8/96	5:30	0.2	
23/08/96	5:45	0.27								23/8/96	6:30	0.4	
23/08/96	6:00	0.26								23/8/96	7:00	0.6	
23/08/96	6:15	0.21								23/8/96	7:30	0.2	
23/08/96	6:30	0.57								23/8/96	8:00	0.2	
23/08/96	6:45	2.01											
23/08/96	7:00	1.15											
23/08/96	7:15	1.21											
23/08/96	7:30	0.72											
23/08/96	7:45	0.33	7.05	23/8/96	7								1.6
23/08/96	9:30	0.27											
23/08/96	10:15	0.32											
23/08/96	10:30	0.28											
23/08/96	11:15	0.29								23/8/96	11:00	0.2	
23/08/96	11:30	0.45								23/8/96	12:00	0.4	
23/08/96	12:00	0.64								23/8/96	12:30	0.2	
23/08/96	12:15	1.53								23/8/96	13:30	0.2	
23/08/96	12:30	1.6								23/8/96	15:30	0.2	
23/08/96	12:45	0.87								23/8/96	21:30	0.2	
23/08/96	13:00	1.82								24/8/96	6:00	2	
23/08/96	13:15	1.65								24/8/96	6:30	1.8	
23/08/96	13:30	1.46								24/8/96	7:00	1.4	
23/08/96	13:45	1.25								24/8/96	7:30	1.2	
23/08/96	14:00	0.79								24/8/96	8:00	0.8	
23/08/96	14:15	1.24								24/8/96	8:30	0.8	
23/08/96	14:30	0.79											
23/08/96	14:45	0.45											
23/08/96	15:00	0.65											
23/08/96	15:15	0.33											
23/08/96	15:30	0.78											
23/08/96	15:45	0.43											
23/08/96	16:00	0.97											
23/08/96	16:15	1.94											
23/08/96	16:30	0.81											
23/08/96	17:30	0.38											
23/08/96	19:00	0.32											
24/08/96	2:30	0.58											
24/08/96	2:45	0.76											
24/08/96	3:00	0.82											
24/08/96	3:15	0.64											
24/08/96	3:30	0.81											
24/08/96	3:45	0.68											
24/08/96	4:00	0.61											

Date	Time	WRG	Daily Total	Date	ORG	Date	Time	SRRG	Daily Total	Date	Time	Tipping bucket	Daily Total
24/08/96	4:15	0.44											
24/08/96	4:30	0.73											
24/08/96	5:00	1.31											
24/08/96	5:15	2.07											
24/08/96	5:30	2.15											
24/08/96	6:00	3.73											
24/08/96	6:15	2.09											
24/08/96	6:30	1.5											
24/08/96	6:45	1.17											
24/08/96	7:00	1.89											
24/08/96	7:15	1.38											
24/08/96	7:30	0.98											
24/08/96	7:45	0.45	47.1	24/8/96	43.6								9.4
27/08/96	19:00	5.4											
27/08/96	19:30	1.69	7.09	28/8/96	6.2								
29/08/96	17:30	0.13											
29/08/96	18:00	0.91											
29/08/96	18:15	0.19	FAILE D		61.2								
02/09/96	3:00	0.18											
02/09/96	3:15	1.32											
02/09/96	3:30	2.42											
02/09/96	3:45	9.66											
02/09/96	4:00	7.88											
02/09/96	4:15	0.83											
02/09/96	8:30	3.04	25.33	2/9/96	32					2/9/96	10:00	2	
02/09/96	8:45	1.37								2/9/96	10:30	3.8	
02/09/96	9:00	0.42								2/9/96	11:00	2.8	
02/09/96	9:30	33.21								2/9/96	11:30	1.8	
02/09/96	17:30	0.13								2/9/96	12:00	1.2	
			35.13	3/9/96	4.5					3/9/96	8:00	0.2	11.8
										3/9/96	9:00	0.2	
04/09/96	7:15	2.35								4/9/96	4:00	0.2	
04/09/96	7:30	7.52								4/9/96	7:30	2.2	
04/09/96	7:45	2.97								4/9/96	8:00	1.2	
04/09/96	8:00	2.76								4/9/96	8:30	1.2	
04/09/96	8:15	3.85											
04/09/96	8:30	4.18	23.63	4/9/96	24					4/9/96	9:00	0.6	5
04/09/96	8:45	1.63								4/9/96	9:30	0.6	
04/09/96	9:00	1.76								4/9/96	10:00	0.2	
04/09/96	9:15	1.12								4/9/96	10:30	0.2	
04/09/96	9:30	1.3											
04/09/96	9:45	0.91											
04/09/96	10:00	0.51											
04/09/96	10:15	0.61											

Date	Time	WRG	Daily Total	Date	ORG	Date	Time	SRRG	Daily Total	Date	Time	Tipping bucket	Daily Total
04/09/96	10:30	0.25											
04/09/96	10:45	0.2											
04/09/96	11:00	0.13											
04/09/96	14:00	0.12											
04/09/96	14:15	0.14											
04/09/96	17:15	0.13	8.81	5/9/96	6								1.6
07/09/96	11:30	0.26								7/9/96	11:30	0.2	
07/09/96	11:45	0.13								7/9/96	12:30	0.2	
07/09/96	12:00	0.13								7/9/96	16:00	0.2	
07/09/96	12:15	0.13											
07/09/96	14:15	0.13											
07/09/96	14:30	0.32											
07/09/96	14:45	0.13											
07/09/96	15:15	0.29											
07/09/96	15:30	0.17	1.69	8/9/96	1.5								
08/09/96	12:15	6.41											
08/09/96	12:30	14.79								8/9/96	12:30	1.2	0.6
08/09/96	12:45	0.78								8/9/96	13:00	0.6	
08/09/96	13:00	0.73								8/9/96	13:30	0.6	
08/09/96	13:15	0.25								8/9/96	14:00	0.4	
08/09/96	16:00	0.11								8/9/96	14:30	0.4	
										8/9/96	15:00	0.4	
										8/9/96	15:30	0.2	
										8/9/96	16:00	0.2	
										8/9/96	16:30	0.2	
										8/9/96	17:30	0.2	
										8/9/96	18:00	0.4	
										8/9/96	18:30	0.4	
										8/9/96	19:00	0.4	
										8/9/96	19:30	0.2	
										8/9/96	20:00	0.4	
										8/9/96	20:30	0.2	
										8/9/96	21:00	0.4	
										8/9/96	21:30	0.2	
										8/9/96	22:00	0.2	
										8/9/96	22:30	0.2	
										8/9/96	23:00	0.2	
										8/9/96	23:30	0.2	
										9/9/96	0:00	0.2	
										9/9/96	1:00	0.2	
										9/9/96	2:00	0.2	
										9/9/96	3:00	0.2	
										9/9/96	5:30	0.2	8.2
										9/9/96	10:00	5.2	
										9/9/96	10:30	3.4	
										9/9/96	12:30	0.2	
										9/9/96	13:00	0.4	
10/09/96	4:30	0.55	23.07	9/9/96	123.7								
10/09/96	5:00	1.6											
10/09/96	5:30	3.54											
10/09/96	6:00	7.36											

10/09/96	6:30	4.8									9/9/96	13:30	0.2	
Date	Time	WRG	Daily Total	Date	ORG	Date	Time	SRRG	Daily Total	Date	Time	Tipping bucket	Daily Total	
10/09/96	7:00	3.67								9/9/96	14:00	0.2		
10/09/96	7:30	3.03						1.5		10/9/96	4:30	0.4		
10/09/96	8:00	3.18						3		10/9/96	5:00	0.4		
10/09/96	8:30	4.38						6		10/9/96	5:30	1		
								5		10/9/96	6:00	1.2		
								3.5		10/9/96	6:30	0.8		
								4.5		10/9/96	7:00	0.8		
										10/9/96	7:30	0.4		
										10/9/96	8:00	0.6		
			32.11	10/9/96	35.6					10/9/96	8:30	0.8	16	
10/09/96	9:00	3.27								10/9/96	9:00	0.8		
10/09/96	9:30	3.86								10/9/96	9:30	0.4		
10/09/96	10:00	0.64	7.77	11/9/96	5.6					11/9/96			1.2	
13/09/96	11:15	1.44				13/9/96	10:45	0.3		13/9/96	11:00	0.4		
13/09/96	11:30	11.39				13/9/96	11:00	1.2		13/9/96	11:30	4		
13/09/96	11:45	8.58				13/9/96	11:15	3.5		13/9/96	12:00	0.2		
13/09/96	12:00	1.12				13/9/96	11:30	5		13/9/96	13:00	0.6		
13/09/96	12:15	0.52				13/9/96	11:45	8						
13/09/96	12:30	0.31				13/9/96	12:00	0.5						
13/09/96	13:00	1.19				13/9/96	12:15	0.5						
13/09/96	13:15	1.42	25.97	14/9/96	23.3	13/9/96	13:15	1.5	20.5				5.2	
15/09/96	17:00	1.23				15/9/96	17:00	2		15/9/96	17:00	2.6		
15/09/96	17:15	36.46				15/9/96	17:15	28		15/9/96	17:30	5		
15/09/96	17:30	3.27	40.96	16/9/96	37	15/9/96	17:30	0.5	30.5	16/9/96	8:00	0.2	7.8	
18/09/96	10:15	0.35								18/9/96	10:30	3.6		
18/09/96	10:30	15.5								18/9/96	11:00	0.2		
18/09/96	10:45	4.51								18/9/96	11:30	0.6		
18/09/96	11:30	1.05								19/9/96	2:00	0.2		
18/09/96	11:45	2.27	23.68	19/9/96	21.8					19/9/96	2:30	0.2	4.8	
03/10/96	23:45	0.57								4/10/96	0:00	0.8		
04/10/96	0:00	3.52								4/10/96	0:30	0.6		
04/10/96	0:15	2.49								4/10/96	1:00	0.2		
04/10/96	0:30	0.76								4/10/96	2:30	1.6		
04/10/96	0:45	0.34								4/10/96	3:30	0.4		
04/10/96	1:00	0.73												
04/10/96	2:15	3.51												
04/10/96	2:30	4.31												
04/10/96	3:15	0.32												
04/10/96	3:30	1.05												
04/10/96	4:15	0.23												
04/10/96	4:30	0.39	18.22	4/10/96	16								3.6	

DIRECTOR

S M SETH

STUDY GROUP

DIVISIONAL HEAD : K S RAMASASTRI

SCIENTIST : V C GOYAL

**SUPPORTING STAFF : P S DAS.
SATYA PRAKASH**