

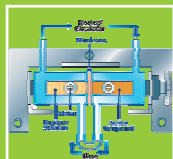

TECHNICAL EIA GUIDANCE MANUAL FOR CHLOR-ALKALI INDUSTRY

Prepared for
The Ministry of Environment and Forests
Government of India



by
IL&FS Ecosmart Limited
Hyderabad

August 2010

PROJECT TEAM

Project Coordination
Ministry of Environment & Forests

Dr. Nalini Bhat
Advisor, Ministry of Environment and Forests
Dr. T. Chandni
Director, Ministry of Environment and Forests

Core Project Coordination Team
IL&FS Environment

Mr. Mahesh Babu
CEO
Mr. N. Sateesh Babu
Vice President & Project Director
Mr. B.S.V. Pavan Gopal
Manager –Technical
Mr. Padmanabhachar. K
Environmental Engineer
Mr. Vijaya Krishna. D
Senior Environmental Engineer
Ms. Chaitanya Vangeti
Assistant Manager - Technical
Ms. Suman Benedicta Thomas
Technical Writer

Resource Person

Dr. I. Haq
Visiting Professor, Jamia Millia Islamia University

Expert Core & Peer Committee
Chairman

Dr. V. Rajagopalan, IAS
Additional Secretary
Ministry of Chemicals & Fertilizers

Core Members

Dr. R. K. Garg
Former Chairman, EIA Committee, Ministry of Environment and Forests
Mr. Paritosh C. Tyagi
Former Chairman, Central Pollution Control Board
Prof. S.P. Gautam
Chairman, Central Pollution Control Board
Dr. Tapan Chakraborti
Director, National Environmental Engineering Research Institute
Mr. K. P. Nyati
Former Head, Environmental Policy, Confederation of Indian Industry
Dr. G.K. Pandey
Former Advisor, Ministry of Environment and Forests
Dr. Nalini Bhat
Advisor, Ministry of Environment and Forests
Dr. G.V. Subramaniam
Advisor, Ministry of Environment and Forests
Dr. B. Sengupta
Former Member Secretary, Central Pollution Control Board
Dr. R. C. Trivedi
Former Scientist, Central Pollution Control Board

Peer Member

Mr. N. K. Verma
Former AD, Central Pollution Control Board

Member Convener

Mr. N. Sateesh Babu
Project Director

TABLE OF CONTENTS

1. INTRODUCTION TO THE TECHNICAL EIA GUIDANCE MANUALS PROJECT	1-1
1.1 Purpose.....	1-2
1.2 Project Implementation.....	1-4
1.3 Additional Information.....	1-4
2. CONCEPTUAL FACETS OF EIA	2-1
2.1 Environment in EIA Context.....	2-1
2.2 Pollution Control Strategies.....	2-2
2.3 Tools for Preventive Environmental Management.....	2-2
2.3.1 Tools for assessment and analysis.....	2-3
2.3.2 Tools for action.....	2-5
2.3.3 Tools for communication.....	2-10
2.4 Objectives of EIA.....	2-10
2.5 Types of EIA.....	2-11
2.6 Basic EIA Principles.....	2-12
2.7 Project Cycle.....	2-13
2.8 Environmental Impacts.....	2-13
2.8.1 Direct impacts.....	2-14
2.8.2 Indirect impacts.....	2-14
2.8.3 Cumulative impacts.....	2-15
2.8.4 Induced impact.....	2-15
2.9 Significance of Impacts.....	2-16
2.9.1 Criteria/methodology to determine the significance of the identified impacts..	2-17
3. ABOUT CHLOR-ALKALI INDUSTRY INCLUDING PROCESS AND POLLUTION CONTROL TECHNOLOGIES	3-1
3.1 Introduction.....	3-1
3.1.1 Production & demand of chlorine.....	3-2
3.1.2 Shift towards membrane technology in India.....	3-4
3.2 Scientific Aspects.....	3-5
3.2.1 Industrial processes.....	3-7
3.2.2 Auxiliary processes.....	3-15
3.2.3 Raw Material inputs in the production line.....	3-19
3.2.4 Qualitative and quantitative analysis of pollutants and rejects.....	3-20
3.2.5 Exposure pathways.....	3-24
3.3 Technological Aspects.....	3-25
3.3.1 Natural resource conservation.....	3-25
3.3.2 Cleaner technologies.....	3-25
3.3.3 Waste minimization opportunities.....	3-27
3.3.4 Pollution control technologies.....	3-28
3.4 Summary of Applicable National Regulations.....	3-29

3.4.1	General description of major statutes	3-29
3.4.2	General standards for discharge of environmental pollutants	3-29
3.4.3	Industry-specific requirements	3-29
4.	OPERATIONAL ASPECTS OF EIA	4-1
4.1	Coverage of Chlor-alkali Industry under the Purview of Notification.....	4-1
4.2	Screening.....	4-5
4.2.1	Applicable conditions for Category B projects.....	4-5
4.2.2	Criteria for classification of Category B1 and B2 projects.....	4-6
4.2.3	Application for prior environmental clearance	4-6
4.2.4	Siting guidelines	4-6
4.3	Scoping for EIA Studies.....	4-8
4.3.1	Pre-feasibility report.....	4-9
4.3.2	Guidance for providing information in Form 1	4-10
4.3.3	Identification of appropriate valued environmental components	4-11
4.3.4	Methods for identification of impacts.....	4-11
4.3.5	Testing the Significance of Impacts	4-16
4.3.6	Terms of reference for EIA studies	4-16
4.4	Environmental Impact Assessment	4-21
4.4.1	EIA team.....	4-21
4.4.2	Baseline quality of the environment	4-22
4.4.3	Impact prediction tools	4-25
4.4.4	Significance of the impacts.....	4-25
4.5	Social Impact Assessment.....	4-26
4.6	Risk Assessment.....	4-29
4.6.1	Storage and handling of hazardous materials	4-33
4.6.2	Hazard identification	4-33
4.6.3	Hazard assessment and evaluation.....	4-33
4.6.4	Disaster management plan.....	4-35
4.7	Mitigation Measures.....	4-39
4.7.1	Important considerations for mitigation methods.....	4-39
4.7.2	Hierarchy of elements of mitigation plan	4-40
4.7.3	Typical mitigation measures.....	4-41
4.8	Environmental Management Plan	4-44
4.9	Reporting.....	4-45
4.10	Public Consultation	4-46
4.11	Appraisal.....	4-49
4.12	Decision Making	4-51
4.13	Post-clearance Monitoring Protocol.....	4-52
5.	STAKEHOLDERS' ROLES AND RESPONSIBILITIES	5-1
5.1	SEIAA.....	5-4
5.2	EAC and SEAC.....	5-6

LIST OF TABLES

Table 3-1: Reactions	3-6
Table 3-2: MRCP Characteristics	3-11
Table 3-3: DCP Characteristics	3-12
Table 3-4: MBCP Characteristics	3-14
Table 3-5: Inputs per Tonne of Chlorine Produced	3-19
Table 3-6: Effects of Mercury based plants on the Environment	3-24
Table 4-1: Advantages and Disadvantages of Impact Identification Methods	4-11
Table 4-2: Matrix of Impacts	4-13
Table 4-3: List of Important Physical Environment Components and Indicators of EBM.....	4-23
Table 4-4: Choice of Models for Impact Predictions: Risk Assessment.....	4-30
Table 4-5: Typical Mitigation Measures.....	4-42
Table 4-6: Structure of EIA Report.....	4-45
Table 5-1: Roles and Responsibilities of Stakeholders Involved in Prior Environmental Clearance	5-1
Table 5-2: Organization-specific Functions.....	5-2
Table 5-3: SEIAA: Eligibility Criteria for Chairperson / Members / Secretary	5-5
Table 5-4: EAC/SEAC: Eligibility Criteria for Chairperson / Members / Secretary	5-9

LIST OF FIGURES

Figure 2-1: Inclusive Components of Sustainable Development.....	2-1
Figure 2-2: Types of Impacts.....	2-14
Figure 2-3: Cumulative Impact.....	2-15
Figure 3-1: Global Consumption Pattern of Chlorine (in percentage).....	3-2
Figure 3-2: Global Consumption Pattern of Caustic Soda (in percentage).....	3-3
Figure 3-3: Caustic Soda Demand in India (in percentage).....	3-3
Figure 3-4: Chlorine Demand in India.....	3-4
Figure 3-5: Chlor-alkali Plant Scheme.....	3-6
Figure 3-6: Flow Diagram of the Three Main Chlor-Alkali Processes.....	3-8
Figure 3-7: Simplified Scheme of Mercury Electrolysis Cells.....	3-9
Figure 3-8: MRCP Structural Layout.....	3-10
Figure 3-9: Simplified Scheme of Diaphragm Electrolysis Cells.....	3-12
Figure 3-10: DCP Scheme.....	3-13
Figure 3-11: Simplified Scheme of Membrane Electrolysis Cells.....	3-13
Figure 3-12: Flow Scheme of Chlorine Gas Treatment.....	3-16
Figure 4-1: Prior Environmental Clearance Process for Activities falling Under Category A.....	4-3
Figure 4-2: Prior Environmental Clearance Process for Activities Falling Under Category B.....	4-4
Figure 4-3: Approach for EIA Study.....	4-21
Figure 4-4: Risk Assessment – Conceptual Framework.....	4-30
Figure 4-5: Comprehensive Risk Assessment - At a Glance.....	4-32

Figure 4-6: Elements of Mitigation 4-40

ANNEXURES

Annexure I

A Compilation of Legal Instruments

Annexure II

General Standards for Discharge of Environmental Pollutants as per CPCB

Annexure III

Form 1 (Application Form for Obtaining EIA Clearance)

Annexure IV

Critically Polluted Industrial Areas and Clusters / Potential Impact Zone

Annexure V

Pre-feasibility Report: Points for Possible Coverage

Annexure VI

Types of Monitoring and Network Design Considerations

Annexure VII

Guidance for Assessment of Baseline Components and Attributes

Annexure VIII

Sources of Secondary Data

Annexure IX

Impact Prediction Tools

Annexure X

Form through which the State Government/Administration of the Union Territories Submit Nominations for SEIAA and SEAC for the Consideration and Notification by the Central Government.

Annexure XI

Composition of EAC/SEAC

Annexure XII

Best Practices & Latest Technologies available and reference

ACRONYMS

AAQ	Ambient Air Quality
AC	Alternating Current
B/C	Benefits Cost Ratio
BAT	Best Available Technology
BOD	BioChemical Oxygen Demand
BOQ	Bill of Quantities
BOT	Build Operate Transfer
BREF	BAT Reference Documents
CaCO ₃	Calcium Carbonate
CCA	Conventional Cost Accounting
CER	Corporate Environmental Reports
CEAA	Canadian Environmental Assessment Agency
CFE	Consent for Establishment
Cl ₂	Chlorine
CPCB	Central Pollution Control Board
CREP	Corporate Responsibility for Environmental Protection
CRZ	Coastal Regulatory Zone
CxCl _y H _z	Chlorinated Hydrocarbons
DC	Direct Current
DCP	Diaphragm Cell Process
DfE	Design for Environment
DMP	Disaster Management Plan
EAC	Expert Appraisal Committee
ECI	Environmental Condition Indicators
EcE	Economic-cum-Environmental
EIA	Environmental Impact Assessment
EIS	Environmental Information System
EMA	Environmental Management Accounting
EMP	Environmental Management Plan
EMS	Environmental Management System
EPI	Environmental Performance indicators
ES	Environmental Statements
FCA	Full Cost Assessment
H ₂	Hydrogen
HAZOP	Hazard and Operability Studies

HTL	High Tide Level
IL&FS	Infrastructure Leasing & Financial Services Limited
IVI	Importance Value Index
ISO	International Standard Organization
KOH	Potassium Hydroxide
LCA	Life Cycle Assessment
LDAR	Leak Detection and Repair
LTL	Low Tide Level
MBCP	Membrane Cell Process
MCA	Maximum Credible Accident
Mg(OH) ₂	Magnesium Hydroxide
MoEF	Ministry of Environment & Forests
MRCP	Mercury Cell Process
NaCl	Sodium Chloride
NaClO	Sodium Hypochlorite
NaClO ₃	Sodium Chlorate
NaOH	Sodium Hydroxide/Caustic Soda
NaOCl	Sodium Hypochlorite
NAQM	National Air Quality Monitoring
NCl ₃	Nitrogen Trichloride
NGO	Non-Government Organizations
O&M	Operation and Maintenance
OH	Hydroxide Ions
OECD	Organization for Economic Co-operation and Development
PM	Particulate Matter
PPA	Participatory Poverty Assessment
PRA	Participatory Rural Appraisal
PTFE	Polytetrafluoro ethylene
PVC	Polyvinyl Chloride
QA/QC	Quality Assurance/Quality Control
QRA	Quantitative Risk Assessment
SEA	Strategic Environmental Assessment
SEAC	State Level Expert Appraisal Committee
SEIAA	State Level Environment Impact Assessment Authority
SEZ	Special Economic Zone
SIA	Social Impact Assessment
SPCB	State Pollution Control Board
SPM	Suspended Particulate Matter
TA	Technology Assessment

TCA	Total Cost Assessment
TEQM	Total Environmental Quality Movement
TGM	Technical EIA Guidance Manual
ToR	Terms of Reference
VCM	Vinyl Chloride Monomer
UT	Union Territory
UTEIAA	Union Territory Level Environment Impact Assessment Authority
UTPCC	Union Territory Pollution Control Committee

Mahesh Babu
Chief Executive Officer

Acknowledgement

The Notification issued on the prior environmental clearance process by the Ministry of Environment and Forests (MoEF) on September 14, 2006 delegated substantial powers to the State Level Environment Impact Assessment Authorities (SEIAA) to grant environmental clearance for certain categories of developmental activities/projects. It was felt that proper guidance to the stakeholders would enhance appreciation of environmental impacts of proposed projects and possible mitigation measures. Further, such a guidance would also help ensure that decision making authorities across different States and Union Territories could adopt similar considerations and norms with due weightage for site-specific considerations.

We feel privileged to be part of the interventions being spearheaded by Sh. Jairam Ramesh, Hon'ble Minister, MoEF, Government of India, to mainstream environmental considerations in the decision making process. IL&FS Ecosmart as part of this important initiative, prepared Technical EIA Guidance Manuals for 27 identified development activities. In view of the diversity of 27 developmental activities entrusted to IL&FS Ecosmart Ltd., in consultation with the MoEF, an expert Peer and Core Committee was constituted to review and finalize each of the draft Manuals. The Manuals prepared by IL&FS were technically reviewed and up-dated by the respective sector-specific expert resource persons.

The Manuals designed by the Expert Committee have benefitted from the advise and feedback received from MoEF. The Manuals are designed to provide readers with an in-depth understanding of the environmental clearance mechanism, developmental activity specific environmental impacts with possible mitigation measures, environmentally compliant manufacturing/ production processes and pollution control technologies, etc.

IL&FS Ecosmart hopes that these Manuals are a step forward to realize the MoEF's desired objective of enhancing functional efficiency and effectiveness in the environmental clearance process. We hope the stakeholders will find the Manuals useful.

We take this opportunity to convey our appreciation to the MoEF team under the leadership of Mr. J.M. Mauskar, Additional Secretary, for the technical inputs, guidance and support extended throughout the project period for successful completion of the project. The technical guidance and support extended by the Expert Peer and Core Committee under the Chairmanship of Dr. V. Rajagopalan, former Chairman, Central Pollution Control Board and inputs of the sector-specific resource persons are gratefully acknowledged.

(Mahesh Babu)

15th November 2010



22nd December 2010

FOREWORD

The Ministry of Environment & Forests (MOEF) introduced the Environmental Impact Assessment (EIA) Notification 2006 on 14th September 2006, which not only reengineered the entire environment clearance (EC) process specified under the EIA Notification 1994, but also introduced a number of new developmental sectors which would require prior environmental clearance. The EIA Notification 2006 has notified a list of 39 developmental sectors which have been further categorised as A or B based on their capacity and likely environmental impacts. Category B projects have been further categorised as B1 and B2. The EIA Notification 2006 has further introduced a system of screening, scoping and appraisal and for the setting up of Environment Impact Assessment Authority (EIAA) at the Central level and State Level Environment Impact Assessment Authorities (SEIAAs) to grant environmental clearances at the Central and State level respectively. The Ministry of Environment & Forests is the Environment Impact Assessment Authority at the Central level and 25 State Level Environment Impact Assessment Authorities (SEIAAS) have been set up in the various States/UTs. The EIA Notification 2006 also stipulates the constitution of a multi-disciplinary Expert Appraisal Committee (EAC) at the Centre and State level Expert Appraisal Committees (SEACs) at State/UT Level for appraisal of Category A or B projects respectively and to recommend grant/rejection of environmental clearance to each project/activities falling under the various sectors to the EIAA/SEIAAs respectively.

Although the process of obtaining environmental clearance consisting of Screening, Scoping and Appraisal and for undertaking public consultation including the process of conduct of Public Hearing has been elaborated under the EIA Notification 2006, the Notification itself provides for bringing out guidelines from time to time on the EIA Notification 2006 and the EC process with a view to bringing clarity on the EC process for expediting environmental clearance. This need was further reinforced after the constitution of SEIAAs and SEACs in various States, who were assigned the task for the first time and for addressing the concerns of standardization of the quality of appraisal and in reducing inconsistencies between SEACs/SEIAAs in granting ECs for similar projects in different States.

The Technical Guidance Manual of "Chlor-Alkali Industry" sector describes types of process and pollution control technologies, operational aspects of EIA with model TOR of that Sector, technological options with cleaner production and waste minimization techniques,

monitoring of environmental quality, post clearance monitoring protocol, related regulations, and procedure of obtaining EC if linked to other clearances for e.g., CRZ, etc.

The manufacture of chlorine and caustic soda from brine involves three basic alternative process -mercury cell, diaphragm cell, and membrane cell. The membrane cell process is the most modern and has economic and environmental advantages and is being presently used. The two other processes generate hazardous wastes (containing mercury or asbestos). Use of mercury cell process is banned by the Govt. of India to reduce the mercury pollution. The implementation of cleaner production processes and pollution prevention measures can provide both economic and environmental benefits.

India's industrial competitiveness and environmental future depends on Industries such as Chlor-Alkali Industry adopting energy and resource efficient technologies. Recycling and reuse of materials is critical. To keep pace with changing technologies and needs of sustainable development, the manual would require regular updating in the future. The manual will be available on the MoEF website and we would appreciate receiving responses from stakeholders for further improvements.

I congratulate the entire team of IL&FS Ecosmart Ltd., experts from the sector who were involved in the preparation of the Manuals, Chairman and members of the Core and Peer Committees of various sectors and various Resource Persons whose inputs were indeed valuable in the preparation and finalization of the Manuals.



(Jairam Ramesh)

1. INTRODUCTION TO THE TECHNICAL EIA GUIDANCE MANUALS PROJECT

Environmental Impact Assessment (EIA) is a process of identifying, predicting, evaluating and mitigating the biophysical, social, and other relevant effects of development proposals prior to major decisions being taken and commitments made. These studies integrate the environmental concerns of developmental activities into the process of decision-making.

EIA has emerged as one of the successful policy innovations of the 20th Century in the process of ensuring sustained development. Today, EIA is formalized as a regulatory tool in more than 100 countries for effective integration of environmental concerns in the economic development process. The EIA process in India was made mandatory and was also given a legislative status through a Notification issued by the ministry of environment and forests (MoEF) in January 1994. The Notification, however, covered only a few selected industrial developmental activities. While there are subsequent amendments, the Notification issued on September 14, 2006 supersedes all the earlier Notifications, and has brought out structural changes in the clearance mechanism.

The basic tenets of this EIA Notification could be summarized into the following:

- Pollution potential as the basis for prior environmental clearance instead of investment criteria; and
- Decentralization of clearing powers to the State/Union Territory (UT) level Authorities for certain developmental activities to make the prior environmental clearance process quicker, transparent and effective.

Devolution of the power to grant clearances at the state level for certain category of the developmental activities / projects is a step forward to fulfill the basic tenets of the re-engineering *i.e.*, quicker, transparent and effective process but many issues impede/hinder its functional efficiency. These issues could be in technical and operational domains as listed below:

Technical issues

- Ensuring level playing ground to avoid arbitrariness in the decision-making process
- Classification of projects which do not require public hearing and detailed EIA (Category B2)
- Variations in drawing Terms of Reference (ToR) of EIA studies for a given developmental activity across the States/UTs
- Varying developmental-activity-specific expertise requirement for conducting EIA studies and their appraisal
- Availability of adequate sectoral experts and variations in competency levels
- Inadequate data verification, cross checking tools and supporting institutional framework

- Meeting time targets without compromising with the quality of assessments/ reviews
- Varying knowledge and skill levels of regulators, consultants and experts
- Newly added developmental activities for prior environmental clearance, *etc.*

Operational issues

- State level /UT level EIA Authorities (SEIAA/UTEIAA) are formulated for the first time and many are functioning
- Varying roles and responsibilities of involved organizations
- Varying supporting institutional strengths across the States/UTs
- Varying manpower availability, *etc.*

1.1 Purpose

The purpose of developing the sector-specific technical EIA guidance manuals (TGM) is to provide clear and concise information on EIA to all the stakeholders *i.e.*, the project proponent, the consultant, the reviewer, and the public. The TGMs are organized to cover following:

Chapter 1 (Introduction): This chapter provides a brief introduction on the EIA, basic tenets of EIA Notification, technical & operational issues in the process of clearance, purpose of the TGMs, project implementation process and additional information.

Chapter 2 (Conceptual facets of an EIA): Provides an overall understanding to the conceptual aspects of control of pollution and EIA for the developmental projects. This basic understanding would set the readers at same level of understanding for proper interpretations and boundaries for identifying the environmental interactions of the developmental projects and their significance for taking measures of mitigation. This chapter covers the discussion on environment in EIA context *i.e.*, sustainable development, pollution control strategies, preventive environmental management tools, Objectives of EIA, types and basic principles of EIA, project cycle for chlor-alkali industry, understanding on type of environmental impacts and the criteria for the significance analysis.

Chapter 3 (Chlor-alkali industry): The purpose of this chapter is to provide the reader precise information on all the relevant aspects of the industry, which is essential to realize the likely interaction of such developmental activities on the receiving environment. Besides, this Chapter gives a holistic understanding on the sources of pollution and the opportunities for source control.

The specific coverage, which provides precise information on the industry include (i) Introduction – Production & demand of chlorine, Shift towards membrane technology in India (ii) Scientific Aspects – Industrial Processes, Auxiliary processes, Raw Material Inputs in the Production Line, Qualitative and quantitative analysis of pollutants and rejects, Exposure pathways (iii) Technological Aspects – Natural resource conservation, Cleaner technologies, Waste minimization opportunities, Pollution control technologies (iv) Summary of Applicable National Regulations – General description of major statutes, Industry-specific requirements as applicable for this developmental activity.

Chapter 4 (Operational aspects): The purpose of this chapter is to facilitate the stakeholders with clear guidance on coverage of legislative requirements, sequence of steps for obtaining the EIA clearance and each step-wise provisions & considerations.

The coverage of the Chapter include provisions in the EIA Notification regarding chlor-alkali industry, screening (criteria for categorization of B1 and B2, siting guidelines, *etc.*), scoping (pre-feasibility report, guidance for filling form 1, identification of valued environmental components, identification of impacts, *etc.*), arriving at terms of reference for EIA studies, impact assessment studies (EIA team, assessment of baseline quality of environment, impact prediction tools, significance of impacts), social impact assessment, risk assessment considerations, typical mitigation measures, designing considerations for environmental management plan, structure of EIA report for incorporation of study findings, process of public consultation, project appraisal, decision making process and post-clearance monitoring protocol.

Chapter 5 (Roles and responsibilities of various organizations involved in the process of prior environmental clearance): The purpose of this Chapter is to brief the stakeholders on the institutional mechanism and roles & responsibilities of the stakeholders involved in the process of prior environmental clearance. The Coverage of the Chapter include (i) roles and responsibilities of the stakeholders, (ii) organization specific functions, (iii) constitution, composition and decision making process of SEIAA, EAC & SEAC and other conditions, which may be considered.

For any given industry, each topic listed above could alone be the subject of a lengthy volume. However, in order to produce a manageable document, this project focuses on providing summary information for each topic. This format provides the reader with a synopsis of each issue. Text within each section was researched from many sources, and was usually condensed from more detailed sources pertaining to specific topics.

The contents of the document are designed with a view to facilitate addressing of the relevant technical and operational issues as mentioned in the earlier section. Besides, facilitates various stakeholders involved in the EIA clearance process *i.e.*,

- Project proponents will be fully aware of the procedures, common ToR for EIA studies, timelines, monitoring needs, *etc.*, in order to plan the projects/studies appropriately.
- Consultants across India will gain similar understanding about a given sector, and also the procedure for EIA studies, so that the quality of the EIA reports gets improved and streamlined.
- Reviewers across the states/UTs will have the same understanding about an industry sector and would able to draw a benchmark in establishing the significant impacts for the purpose of prescribing the ToR for EIA studies and also in the process of review and appraisal.
- Public who are concerned about a new or expansion projects, can use this manual to get a basic idea about the manufacturing/production details, rejects/wastes from the operations, choice of cleaner/control technologies, regulatory requirements, likely environmental and social concerns, mitigation measures, *etc.*, in order to seek clarifications appropriately in the process of public consultation. The procedural clarity in the document will further strengthen them to understand the stages involved in clearance and roles and responsibilities of various organizations.

- In addition, these manuals would substantially ease the pressure on reviewers at the scoping stage and would bring in functional efficiency at the central and state levels.

1.2 Project Implementation

The Ministry of Environment & Forests (MoEF), Government of India took up the task of developing sector-specific TGMs for all the developmental activities listed in the re-engineered EIA Notification. The Infrastructure Leasing and Financial Services Ecosmart Limited (IL&FS Ecosmart), has been entrusted with the task of developing these manuals for 27 industrial and related sectors. Chlor-alkali industry is one of these sectors, for which this manual is prepared.

The ability to design comprehensive EIA studies for specific industries depends on the knowledge of several interrelated topics. Therefore, it requires expert inputs from multiple dimensions *i.e.*, administrative, project management, technical, scientific, social, economic, risk *etc.*, in order to comprehensively analyze the issues of concern and to draw logical interpretations. Thus, Ecosmart has designed a well-composed implementation framework to factor inputs of the experts and stakeholders in the process of finalization of these manuals.

The process of manual preparation involved collection & collation of the secondary available information, technical review by sectoral resource persons and critical review & finalization by a competent Expert Committee composed of core and sectoral peer members.

The MoEF appreciates the efforts of Ecosmart, Expert Core and Peer Committee, resource persons and all those who have directly and indirectly contributed to this Manual.

1.3 Additional Information

This TGM is brought out by the MoEF to provide clarity to all the stakeholders involved in the 'Prior Environmental Clearance' process. As such, the contents and clarifications given in this document do not withstand in case of a conflict with the statutory provisions of the Notifications and Executive Orders issued by the MoEF from time-to-time.

TGMs are not regulatory documents. Instead, these are the tools designed to assist in successful completion of an EIA.

For the purpose of this project, the key elements considered under TGMs are: conceptual aspects of EIA; developmental activity-specific information; operational aspects; and roles and responsibilities of involved stakeholders.

This manual is prepared considering the Notification issued on 14th September, 2006 and latest amendment as on 1st December 2009. For recent updates, if any, may please refer the website of the MoEF, Government of India *i.e.*, <http://moef.nic.in/index.php>.

2.

CONCEPTUAL FACETS OF EIA

It is an imperative requirement to understand the basic concepts concerned to the pollution control and the environmental impact assessment in an overall objective of the sustainable development. This Chapter highlights the pollution control strategies and their tools besides the objectives, types & principles of EIA, type of impacts their significance analysis, in order to provide consistent understanding to the reader before assessing the development of activity-specific environmental concerns in Chapter 3 and identification & prediction of significant impacts in order to design mitigation measures as detailed in Chapter 4.

2.1 Environment in EIA Context

“Environment” in EIA context mainly focuses, but is not limited to physical, chemical, biological, geological, social, economical, and aesthetic dimensions along with their complex interactions, which affect individuals, communities and ultimately determines their forms, character, relationship, and survival. In EIA context, ‘effect’ and ‘impact’ can often be used interchangeably. However, ‘impact’ is considered as a value judgment of the significance of an effect.

Sustainable development is built on three basic premises *i.e.*, economic growth, ecological balance and social progress. Economic growth achieved in a way that does not consider the environmental concerns, will not be sustainable in the long run. Therefore, sustainable development needs careful integration of environmental, economic, and social needs in order to achieve both an increased standard of living in short term, and a net gain or equilibrium among human, natural, and economic resources to support future generations in the long term.

“It is necessary to understand the links between environment and development in order to make choices for development that will be economically efficient, socially equitable and responsible, as well as environmentally sound.” Agenda 21

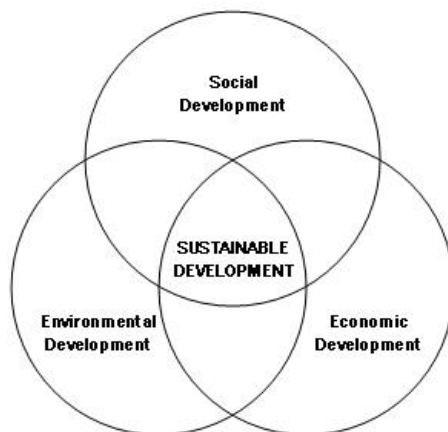

Figure 2-1: Inclusive Components of Sustainable Development

2.2 Pollution Control Strategies

Pollution control strategies can be broadly categorized into preventive and reactive. The reactive strategy refers to the steps that may be applied once the wastes are generated or contamination of the receiving environment takes place. The control technology or a combination of technologies to minimize the impact due to the process rejects/wastes varies with quantity and characteristics, desired control efficiency and economics.

Many combinations of techniques could be adopted for treatment of a specific waste or the contaminated receiving environment, but are often judged based on techno-economic feasibility. Therefore, the best alternative is to take all possible steps to avoid pollution itself. This preventive approach refers to a hierarchy that involves i) prevention & reduction; ii) recycling and re-use; iii) treatment; and iv) disposal, respectively.

Therefore, there is a need to shift the emphasis from the reactive to preventive strategy *i.e.*, to promote preventive environmental management. Preventive environmental management tools may be grouped into management based tools, process based tools and product based tools, which are given below:

Management Based Tools	Process Based Tools	Product Based Tools
Environmental Management System (EMS)	Environmental Technology Assessment	Industrial Ecology
Environmental Performance Evaluation	Toxic Use Reduction	Extended Producers Responsibility
Environmental Audits	Best Operating Practices	Eco-labeling
Environmental Reporting and Communication	Environmentally Best Practice	Design for Environment
Total Cost Accounting	Best Available Technology (BAT)	Life Cycle Assessment (LCA)
Law and Policy	Waste Minimization	
Trade and Environment	Pollution Prevention	
Environmental Economics	Cleaner Production	
	4-R Concept	
	Cleaner Technology	
	Eco-efficiency	

2.3 Tools for Preventive Environmental Management

The tools for preventive environmental management can be broadly classified into following three groups.

- Tools for assessment and analysis - risk assessment, life cycle assessment, total cost assessment, environmental audit / statement, environmental benchmarking, environmental indicators
- Tools for action - environmental policy, market based economic instruments, innovative funding mechanism, EMS and ISO certification, total environmental quality movement, eco-labeling, cleaner production, eco-efficiency, industrial ecosystem or metabolism, voluntary agreements
- Tools for communication - state of environment, corporate environmental reporting

Specific tools under each group are discussed precisely in next sections.

2.3.1 Tools for assessment and analysis

2.3.1.1 Risk assessment

Risk is associated with the frequency of failure and consequence effect. Predicting such situations and evaluation of risk is essential to take appropriate preventive measures. The major concern of the assessment is to identify the activities falling in a matrix of high & low frequencies at which the failures occur and the degree of its impact. The high frequency, low impact activities can be managed by regular maintenance *i.e.*, LDAR (Leak detection and repair) programmes. Whereas, the low frequency, high impact activities are of major concern (accidents) in terms of risk assessment. As the frequency is low, often the required precautions are not realized or maintained. However, the risk assessment identifies the areas of major concerns which require additional preventive measures; likely consequence distances considering domino effects, which will give the possible casualties and ecological loss in case of accidents. These magnitudes demand the attention for preventive and disaster management plans (DMP). Thus is an essential tool to ensure safety of operations.

2.3.1.2 Life cycle assessment

A broader approach followed to deal with environmental impacts during manufacturing is called LCA. This approach recognizes that environmental concerns are associated with every step of the processing w.r.t. manufacturing of the products and also examines environmental impacts of the product at all stages of project life cycle. LCA includes product design, development, manufacturing, packaging, distribution, usage and disposal. LCA is concerned with reducing environmental impacts at all the stages and considering the total picture rather than just one stage of the production process.

Industries/firms may apply this concept to minimize costs incurred on the environmental conservation throughout the project life cycle.

2.3.1.3 Total cost assessment

Total Cost Assessment (TCA) is an enhanced financial analysis tool that is used to assess the profitability of alternative courses of action e.g., raw material substitution to reduce the costs of managing the wastes generated by process; an energy retrofit to reduce the costs of energy consumption. This is particularly relevant for pollution prevention options. These options, because of their nature, often produce financial savings that are overlooked in conventional financial analysis, either because they are misallocated, uncertain, and hard to quantify, or occur more than three to five years after the initial investment. TCA involves all of the relevant costs and savings associated with an option so that it can compete for scarce capital resources fairly, on a level playing field. The assessments are often beneficial w.r.t the following:

- Identification of costly resource inefficiencies
- Financial analysis of environmental activities/projects such as investment in cleaner technologies
- Prioritization of environmental activities/projects
- Evaluation of product mix and product pricing
- Benchmarking against the performance of other processes or against the competitors

A comparison of cost assessments is given below:

- Conventional cost accounting (CCA): Direct and indirect financial costs+ Recognized contingent costs
- Total Cost Assessment (TCA): A broader range of direct, indirect, contingent and less quantifiable costs
- Full Cost assessment (FCA): TCA + External social costs borne by society

2.3.1.4 Environmental audit/statement

Key objectives of an environmental audit includes compliance verification, problem identification, environmental impact measurement, environmental performance measurement, conforming effectiveness of EMS, providing a database for corrective actions and future actions, developing company's environmental strategy, communication and formulating environmental policy.

The MoEF, Government of India issued Notification on 'Environmental Statements' (ES) in April, 1992 and further amended in April 1993 – As per the Notification, the industries are required to submit environmental statements to the respective State Pollution Control Board (SPCB). ES is a proactive tool for self-examination of the industry itself to reduce/minimize pollution by adopting process modifications, recycling and reusing of the resources. The regular submission of ES will indicate the systematic improvement in environmental pollution control being achieved by the industry. In other way, the specific points in ES may be used as environmental performance indicators for relative comparison, implementation and to promote better practices.

2.3.1.5 Environmental benchmarking

Environmental performance and operational indicators could be used to navigate, manage and communicate the significant aspects and give enough evidence of good environmental house keeping. Besides the existing prescribing standards, an insight to identify the performance indicators and prescribing schedule for systematic improvement in performance of these indicators will yield better results.

Relative indicators may be identified for different industrial sectors and be integrated in companies and organizations to monitor and manage the different environmental aspects of the company, to benchmark and compare two or more companies from the same sector. These could cover the water consumption, wastewater generation, energy consumption, solid/hazardous waste generation, chemical consumption *etc.*, per tonne of final product. Once these bench marks are developed, the industries which are below them may be guided and enforced to reach them while those which are better than the benchmark may be encouraged further by giving incentives *etc.*

2.3.1.6 Environmental indicators

Indicators can be classified in to environmental performance indicators (EPI) and environmental condition indicators (ECI). The EPIs can be further divided into two categories *i.e.*, operational performance indicators and management performance indicators.

The operational performance indicators are related to the process and other operational activities of the organization. These would typically address the issue of raw material consumption, energy consumption, water consumption in the organization, the quantities of wastewater generated, other solid wastes & emissions generated, emission from the organization *etc.*

Management performance indicators are related to the management efforts to influence the environmental performance of the organizational operations.

The environmental condition indicators provide information about the environment. These indicators provide information about the local, regional, national or global condition of the environment. This information helps an organization to understand the environmental impacts of its activities and thus helps in taking decisions to improve the environmental performance.

Indicators basically used to evaluate environmental performance against the set standards and thus indicate the direction in which to proceed. Selection of type of indicators for a firm or project depends upon its relevance, clarity and realistic cost of collection and its development.

2.3.2 Tools for action

2.3.2.1 Environmental policy

An environmental policy is a statement of an organization's overall aim and principles of action w.r.t the environment, including compliance with all relevant regulatory requirements. It is a key tool in communicating environmental priorities of the organisation to all its employees. To ensure organization's commitment towards a formulated environmental policy, it is essential for the top management to be involved in the process of formulating the policy and setting priorities. Therefore, the first step is to get the commitment from the higher levels of management. The organization should then conduct an initial environmental review and draft an environmental policy. This draft should be discussed and approved by the board of directors and finally the approved environmental policy statement should then be communicated internally among all its employees and must also be made available to the public.

2.3.2.2 Market-based economic instruments

Market based instruments are regulations that encourage behavior through market signals rather than through explicit directives regarding pollution control levels. These policy instruments such as tradable permits, pollution charge are often described as harnessing market forces. Market based instruments can be categorized into the following four major categories which are discussed below.

- **Pollution charge:** Charge system will assess a fee or tax on the amount of pollution a firm or source generates. It is worthwhile for the firm to reduce emissions to the point, where its marginal abatement costs is equal to the tax rate. Thus firms control pollution to different degrees *i.e.* high cost controllers – less; low-cost controllers – more. The charge system encourages the industries to further reduce the pollutants. The collected charges can form a fund for restoration of the environment. Another form of pollution charge is a deposit refund system, where, consumers pay a surcharge when purchasing a potentially polluting product, and receive a refund on return of the product after useful life span at appropriate centers. The concept of extended producers' responsibility brought in to avoid accumulation of dangerous products in the environment.
- **Tradable permits:** Under this system, firms that achieve the emission levels below their allotted level may sell the surplus permits. Similarly, the firms, which are

required to spend more to attain the required degree of treatment/allotted levels, can purchase permits from others at lower costs and may be benefited.

- **Market barrier reductions:** Three known market barrier reduction types are as follows:
 - Market creation: Measures that facilitate the voluntary exchange of water rights and thus promote more efficient allocation of scarce water supplies
 - Liability concerns: Encourage firms to consider potential environmental damages of their decisions
 - Information programmes: Eco-labeling and energy efficiency product labeling requirements
- **Government subsidy reduction:** Subsidies are the mirror images of taxes and, in theory, can provide incentive to address environmental problems. However, it has been reported that the subsidies encourage economically inefficient and environmentally unsound practices, and often leads to market distortions due to differences in the area. However, these are important to sustain the expansion of production, in the national interests. In such cases, the subsidy may be comparable to the net social benefit.

2.3.2.3 Innovative funding mechanism

There are many forums under which the fund is made available for the issues which are of global/regional concern (GEF, OECD, Deutch green fund, *etc.*) *i.e.*, climate change, Basal convention and further fund sources are being explored for the Persistent Organic Pollutants Convention. Besides the global funding mechanism, there needs to be localized alternative mechanisms for boosting the investment in environmental pollution control. For example, in India the Government has established mechanism to fund the common effluent treatment plants, which are specifically serving the small and medium scale enterprises *i.e.*, 25% share by the State Government, matching grants from the Central Government and surety for 25% soft loan. It means that the industries need to invest only 25% initially, thus encouraging voluntary compliance.

There are some more options *i.e.*, if the pollution tax/charge is imposed on the residual pollution being caused by the industries, municipalities *etc.*, fund will automatically be generated, which in turn, can be utilized for funding the environmental improvement programmes. The emerging concept of build-operate-transfer (BOT) is an encouraging development, where there is a possibility to generate revenue by application of advanced technologies. There are many opportunities which can be explored. However, what is required is the paradigm shift and focused efforts.

2.3.2.4 EMS and ISO certification

EMS is that part of the overall management system, which includes the organizational structure, responsibilities, practices, procedures, process and resources for determining and implementing the forms of overall aims, principles of action w.r.t the environment. It encompasses the totality of organizational, administrative and policy provisions to be taken by a firm to control its environmental influences. Common elements of an EMS are the identification of the environmental impacts and legal obligations, the development of a plan for management & improvement, the assignment of the responsibilities and monitoring of the performance.

2.3.2.5 Total environmental quality movement

Quality is regarded as

- A product attribute that had to be set at an acceptable level and balanced against the cost
- Something delivered by technical systems engineered by experts rather than the organization as a whole
- Assured primarily through the findings and correction of mistakes at the end of the production process

One expression of the total environment quality movement (TEQM) is a system of control called Kaizen. The principles of Kaizen are:

- Goal must be continuous improvement of quality instead of acceptable quality
- Responsibility of the quality shall be shared by all members of an organization
- Efforts should be focused on improving the whole process and design of the products

With some modifications, TEQM approach can be applied in the improvement of corporate environmental performance in both process and product areas.

2.3.2.6 Eco-labeling

Eco-labelling is the practice of supplying information on the environmental characteristics of a product or service to the general public. These labeling schemes can be grouped in to three types:

- Type I: Multiple criteria base; third party (Govt. or non-commercial private organizations) programme claims overall environmental preferability.
- Type II: Specific attribute of a product; often issued by a company/industrial association
- Type III: Agreed set of indices; provide quantified information; self declaration

Among the above, Type I are more reliable because they are established by a third party and considers the environmental impacts of a product from cradle to grave. However, the labeling program will only be effective if linked with complementary program of consumer education and up on restriction of umbrella claims by the producers.

2.3.2.7 Cleaner production

Cleaner production is one of the tools, which has lot of bearing on environmental pollution control. It is also seen that the approach is changing with time *i.e.*, dumping-to-control-to-recycle-to-prevention. Promotion of cleaner production principles involves an insight into the production processes not only to get desired yield but also to optimize on raw material consumption *i.e.*, resource conservation and implications of the waste treatment and disposal.

2.3.2.8 4-R concept

The concept endorses utilization of the wastes as a by-product to the extent possible *i.e.*, Re-cycle, Recover, Reuse, Recharge. Recycling refers to using the wastes/by-products in

the process again as a raw material to maximize the production. Recovery refers to engineering means such as solvent extraction, distillation, precipitation *etc.* to separate the useful constituents of the wastes, so that these recovered materials can be used. Reuse refers to the utilization of waste from one process as a raw material to other. Recharging is an option in which the natural systems are used for renovation of waste for further use.

2.3.2.9 Eco-efficiency

The World Business Council on sustainable development (WBCSD) defines eco-efficiency as “the delivery of competitively priced goods and services that satisfy human needs and bring quality of life, while progressively reducing ecological impacts and resource intensity throughout the life cycle, to a level at least in line with earth’s carrying capacity”. The business implements the eco-efficiency on four levels *i.e.*, optimized processes, recycling of wastes, eco-innovation and new services. Fussler (1995) defined six dimensions of eco efficiency, which are given below to understand/examine the system.

- **Mass:** There is an opportunity to significantly reduce mass burdens (raw materials, fuels, utilities consumed during the life cycle)
- **Reduce energy use:** The opportunity is to redesign the product or its use to provide significant energy savings
- **Reduce environmental toxins:** This is concern to the environmental quality and human health. The opportunity here is to significantly control the dispersion of toxic elements.
- **Recycle when practical:** Designing for recyclability is important
- **Working with mother nature:** Materials are borrowed and returned to the nature without negatively affecting the balance of the ecosystem.
- **Make it Last Longer:** It relates to useful life and functions of products. Increasing the functionality of products also increase their eco efficiency.

The competitiveness among the companies and long-term survival will continue and the successful implementation of eco efficiency will contribute to their success. There is a need to shift towards responsible consumerism equal to the efficiency gains made by corporations – doing more with less.

2.3.2.10 Industrial ecosystem or metabolism

Eco-industrial development is a new paradigm for achieving excellence in business and environmental performance. It opens up innovative new avenues for managing business and conducting economic development by creating linkages among local ‘resources’, including businesses, non-profit groups, governments, unions, educational institutions, and communities. They can creatively foster the dynamic and responsible growth. Antiquated business strategies based on isolated enterprises are no longer responsive enough to market, environmental and community requirements.

Sustainable eco-industrial development looks systematically at development, business and environment, attempting to stretch the boundaries of current practice - on one level. It is as directly practical as making the right connections between the wastes and resources needed for production and at the other level, it is a whole new way of thinking about doing business and interacting with communities. At a most basic level, it is each

organization seeking higher performance within it self. However, most eco-industrial activity is moving to a new level by increasing the inter connections between the companies.

Strategic partnership networked manufacturing and performed supplier arrangements are all the examples of ways used by the businesses to ensure growth, contain costs and to reach out for new opportunities.

For most businesses, the two essentials for success are the responsive markets and access to cost-effective, quality resources for production or delivering services. In absence of these two factors, virtually every other incentive becomes a minor consideration.

Transportation issues are important at two levels, the ability to get goods to market in an expeditious way is essential to success in this day of just in time inventories. The use of least impact transportation with due consideration of speed and cost supports business success and addresses the concerned in the community.

Eco-industrial development works because it consciously mixes a range of targeted strategies shaped to the contours of the local community. Most importantly, it works because the communities wants nothing less than the best possible in or near their neighborhoods. For companies, it provides a path towards significantly higher operating results and positive market presence. For our environment, it provides great hope that the waste will be transformed in to valued product and that the stewardship will be a joint pledge of both businesses and communities.

2.3.2.11 Voluntary agreements

Voluntary environmental agreements among the industries, government, public representatives, NGOs and other concerned towards attaining certain future demands of the environment are reported to be successful. Such agreements may be used as a tool where Government would like to make the standards stringent in future (phase-wise-stringent). These may be used when conditions are temporary and require timely replacement. Also these may be used as supplementary/complimentary in implementation of the regulation. The agreements may include:

- Target objectives (emission limit values/standards)
- Performance objectives (operating procedures)
- R&D activities – Government and industry may have agreement to establish better control technologies.
- Monitoring & reporting of the agreement conditions by other agents (NGOs, public participants, civil authority *etc.*)

In India, the MoEF has organized such programme, popularly known as the corporate responsibility for environment protection (CREP) considering identified 17 categories of high pollution potential industrial sectors. Publication in this regard, is available with Central Pollution Control Board (CPCB).

2.3.3 Tools for communication

2.3.3.1 State of environment

The Government of India has brought out the state of environment report for entire country and similar reports available for many of the states. These reports are published at regular intervals to record trends and to identify the required interventions at various levels. These reports consider the internationally accepted DPSIR framework for the presentation of the information. DPSIR refers to

- D – Driving forces – causes of concern *i.e.*, industries, transportation *etc.*
- P – Pressures – pollutants emanating from driving forces *i.e.* emission
- S – State – quality of environment *i.e.*, air, water & soil quality
- I – Impact – Impact on health, ecosystem, materials, biodiversity, economic damage *etc.*
- R – Responses – action for cleaner production, policies (including standards/guidelines), targets *etc.*

Environment reports including the above elements gives a comprehensive picture of specific target area in order to take appropriate measures for improvement. Such reports capture the concerns, which could be considered in EIAs.

2.3.3.2 Corporate environmental reporting

Corporate environmental reports (CERs) are only one form of environmental reporting defined as publicly available, stand alone reports, issued voluntarily by the industries on their environmental activities. CER is just a means of environmental improvement and greater accountability, not an end in itself.

Three categories of environmental disclosure are:

- Involuntary disclosure: Without its permission and against its will (env. Campaign, press *etc.*)
- Mandatory disclosure: As required by law
- Voluntary disclosure: The disclosure of information on a voluntary basis

2.4 Objectives of EIA

Objectives of EIA include the following:

- To ensure environmental considerations are explicitly addressed and incorporated into the development decision-making process;
- To anticipate and avoid, minimize or offset the adverse significant biophysical, social and other relevant effects of development proposals;
- To protect the productivity and capacity of natural systems and the ecological processes which maintain their functions; and
- To promote development that is sustainable and optimizes resource use as well as management opportunities.

2.5 Types of EIA

Environmental assessments could be classified into four types *i.e.*, strategic environmental assessment, regional EIA, sectoral EIA and project level EIA. These are precisely discussed below:

Strategic environmental assessment

Strategic Environmental Assessment (SEA) refers to systematic analysis of the environmental effects of development policies, plans, programmes and other proposed strategic actions. SEA represents a proactive approach to integrate environmental considerations into the higher levels of decision-making – beyond the project level, when major alternatives are still open.

Regional EIA

EIA in the context of regional planning integrates environmental concerns into development planning for a geographic region, normally at the sub-country level. Such an approach is referred to as the economic-cum-environmental (EcE) development planning. This approach facilitates adequate integration of economic development with management of renewable natural resources within the carrying capacity limitation to achieve sustainable development. It fulfils the need for macro-level environmental integration, which the project-oriented EIA is unable to address effectively. Regional EIA addresses the environmental impacts of regional development plans and thus, the context for project-level EIA of the subsequent projects, within the region. In addition, if environmental effects are considered at regional level, then cumulative environmental effects of all the projects within the region can be accounted.

Sectoral EIA

Instead of project-level-EIA, an EIA should take place in the context of regional and sectoral level planning. Once sectoral level development plans have the integrated sectoral environmental concerns addressed, the scope of project-level EIA will be quite minimal. Sectoral EIA will help in addressing specific environmental problems that may be encountered in planning and implementing sectoral development projects.

Project level EIA

Project level EIA refers to the developmental activity in isolation and the impacts that it exerts on the receiving environment. Thus, it may not effectively integrate the cumulative effects of the development in a region.

From the above discussion, it is clear that EIA shall be integrated at all the levels *i.e.*, strategic, regional, sectoral and the project level. Whereas, the strategic EIA is a structural change in the way the things are evaluated for decision-making, the regional EIA refers to substantial information processing and drawing complex inferences. The project-level EIA is relatively simple and reaches to meaningful conclusions. Therefore in India project-level EIA studies take place on a large scale and are being considered. However, in the re-engineered Notification, provisions have been incorporated for giving a single clearance for the entire industrial estate for e.g., Leather parks, pharma cities *etc.*, which is a step towards the regional approach.

As we progress and the resource planning concepts emerge in our decision-making process, the integration of overall regional issues will become part of the impact assessment studies.

2.6 Basic EIA Principles

By integrating the environmental impacts of the development activities and their mitigation early in the project planning cycle, the benefits of EIA could be realized in all stages of a project, from exploration and planning, through construction, operations, decommissioning, and beyond site closure.

A properly-conducted-EIA also lessens conflicts by promoting community participation, informing decision makers, and also helps in laying the base for environmentally sound projects. An EIA should meet at least three core values:

- Integrity: The EIA process should be fair, objective, unbiased and balanced
- Utility: The EIA process should provide balanced, credible information for decision-making
- Sustainability: The EIA process should result in environmental safeguards

Ideally an EIA process should be:

- Purposive - should inform decision makers and result in appropriate levels of environmental protection and community well-being.
- Rigorous - should apply 'best practicable' science, employing methodologies and techniques appropriate to address the problems being investigated.
- Practical - should result in providing information and acceptable and implemental solutions for problems faced by proponents.
- Relevant - should provide sufficient, reliable and usable information for development planning and decision making.
- Cost-effective - should impose the minimum cost burdens in terms of time and finance on proponents and participants consistent with meeting accepted requirements and objectives of EIA.
- Efficient - should achieve the objectives of EIA within the limits of available information, time, resources and methodology.
- Focused - should concentrate on significant environmental effects and key issues; *i.e.*, the matters that need to be taken into account in making decisions.
- Adaptive - should be adjusted to the realities, issues and circumstances of the proposals under review without compromising the integrity of the process, and be iterative, incorporating lessons learned throughout the project life cycle.
- Participative - should provide appropriate opportunities to inform and involve the interested and affected publics, and their inputs and concerns should be addressed explicitly in the documentation and decision making.
- Inter-disciplinary - should ensure that the appropriate techniques and experts in the relevant bio-physical and socio-economic disciplines are employed, including use of traditional knowledge as relevant.
- Credible - should be carried out with professionalism, rigor, fairness, objectivity, impartiality and balance, and be subject to independent checks and verification.

- Integrated - should address the interrelationships of social, economic and biophysical aspects.
- Transparent - should have clear, easily understood requirements for EIA content; ensure public access to information; identify the factors that are to be taken into account in decision making; and acknowledge limitations and difficulties.
- Systematic - should result in full consideration of all relevant information on the affected environment, of proposed alternatives and their impacts, and of the measures necessary to monitor and investigate residual effects.

2.7 Project Cycle

The generic project cycle including that of the chlor-alkali industry has six main stages:

1. Project concept
2. Pre-feasibility
3. Feasibility
4. Design and engineering
5. Implementation
6. Monitoring and evaluation

It is important to consider the environmental factors on an equal basis with technical and economic factors throughout the project planning, assessment and implementation phases. Environmental considerations should be introduced at the earliest in the project cycle and must be an integral part of the project pre-feasibility and feasibility stage. If the environmental considerations are given due respect in the site selection process by the project proponent, the subsequent stages of the environmental clearance process would get simplified and would also facilitate easy compliance to the mitigation measures throughout the project life cycle.

A project's feasibility study should include a detailed assessment of significant impacts and the EIA include a detailed prediction and quantification of impacts and delineation of Environmental Management Plan (EMP). Findings of the EIA study should preferably be incorporated in the project design stage so that the project as well as the site alternatives is studied and necessary changes, if required, are incorporated in the project design stage. This practice will also help the management in assessing the negative impacts and in designing cost-effective remedial measures. In general, EIA enhances the project quality and improves the project planning process.

2.8 Environmental Impacts

Environmental impacts resulting from proposed actions can be grouped into following categories:

- Beneficial or detrimental
- Naturally reversible or irreversible
- Repairable via management practices or irreparable
- Short term or long term
- Temporary or continuous
- Occurring during construction phase or operational phase
- Local, regional, national or global

- Accidental or planned (recognized before hand)
- Direct (primary) or Indirect (secondary)
- Cumulative or single

The category of impact as stated above, and the significance will facilitate the Expert Appraisal Committee (EAC)/State Level EAC (SEAC) to take a look at the ToR for EIA studies, as well as, in decision making process about the developmental activity.

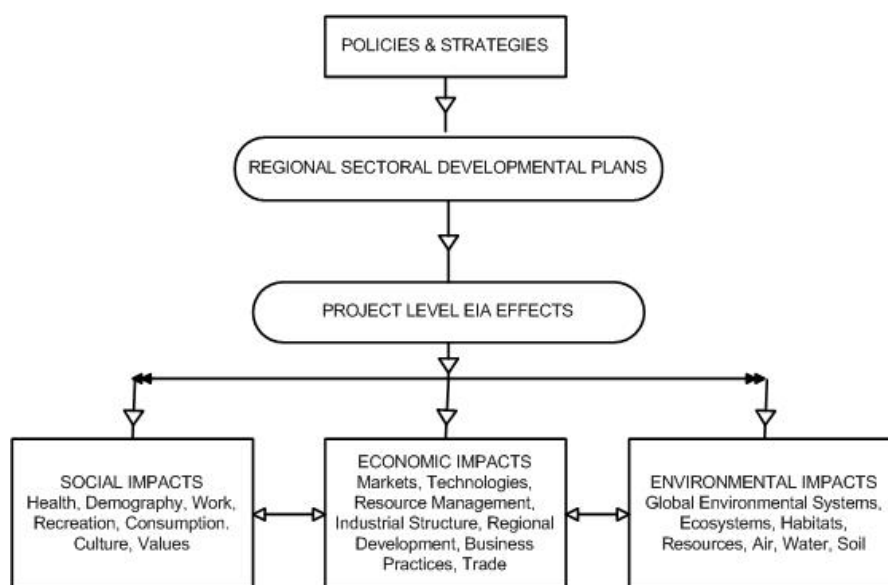

Figure 2-2: Types of Impacts

The nature of impacts could fall within three broad classifications *i.e.*, direct, indirect and cumulative, based on the characteristics of impacts. The assessment of direct, indirect and cumulative impacts should not be considered in isolation or considered as separate stages in the EIA. Ideally, the assessment of such impacts should form an integral part of all stages of the EIA. The TGM does not recommend a single method to assess the types of impacts, but suggests a practical framework/approach that can be adapted and combined to suit a particular project and the nature of impacts.

2.8.1 Direct impacts

Direct impacts occur through direct interaction of an activity with an environmental, social, or economic component. For example, a discharge of chlor-alkali industry or effluent from the Effluent Treatment Plant (ETP) into a river may lead to a decline in water quality in terms of high level of mercury, TDS, free chlorine, alkalinity/acidity affecting biota of river water.

2.8.2 Indirect impacts

Indirect impacts on the environment are those which are not a direct result of the project, often produced away from or as a result of a complex impact pathway. The indirect impacts are also known as secondary or even tertiary level impacts. For example, ambient air SO₂ rise due to stack emissions may deposit on soil which contaminate crops and surface water. Another example of indirect impact is the decline in water quality due to rise in temperature of water bodies receiving cooling water discharge from the nearby industry. This, in turn, may lead to a secondary indirect impact on aquatic flora in that

water body and may further cause reduction in fish population affecting health of the consumer. Reduction in fishing harvests, affecting the incomes of fishermen is a third level impact. Such impacts are characterized as socio-economic (third level) impacts such as pattern of land used, crops, population density. Such impacts also reduce ecosystem productivity due to adverse impact of chlorine, mercury in air and water contamination around the chlor-alkali plant. The indirect impacts may also include growth-inducing impacts and other effects related to induced changes to the pattern of land use or additional road network, population density or growth rate. In the process, air, water and other natural systems including the ecosystem may also be affected.

2.8.3 Cumulative impacts

Cumulative impact consists of an impact that is created as a result of the combination of the project evaluated in the EIA together with other projects in the same vicinity, causing related impacts. These impacts occur when the incremental impact of the project is combined with the cumulative effects of other past, present and reasonably foreseeable future projects. Figure 2-3 depicts the same. Respective EAC may exercise their discretion on a case-by-case basis for considering the cumulative impacts.

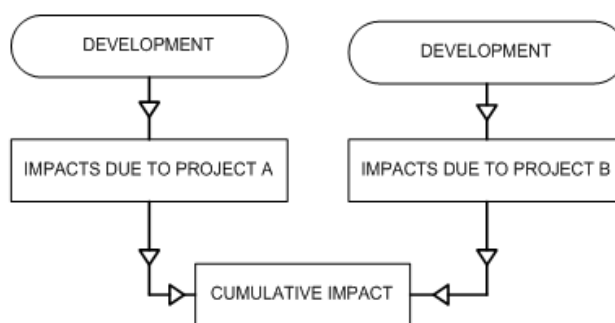

Figure 2-3: Cumulative Impact

2.8.4 Induced impact

The cumulative impacts can be due to induced actions of projects and activities that may occur if the action under assessment is implemented such as growth-inducing impacts and other effects related to induced changes to the pattern of future land use or additional road network, population density or growth rate (e.g., excess growth may be induced in the zone of influence around a project area, and in the process causing additional effects on air, water and other natural ecosystems). Induced actions may not be officially announced or be part of any official plan. Increase in workforce and nearby communities contributes to this effect.

They usually have no direct relationship with the action under assessment, and represent the growth-inducing potential of an action. New roads leading from those constructed for a project, increased recreational activities (e.g., hunting, fishing), and construction of new service facilities are examples of induced actions.

However, the cumulative impacts due to induced development or third level or even secondary indirect impacts are difficult to be quantified. Because of higher levels of uncertainties, these impacts cannot normally be assessed over a long time horizon. An EIA practitioner usually can only guess as to what such induced impacts may be and the

possible extent of their implications on the environmental factors. Respective EAC may exercise their discretion on a case-by-case basis for considering the induced impacts.

2.9 Significance of Impacts

This TGM establishes the significance of impacts first and proceeds to delineate the associated mitigation measures. So the significance here reflects the “worst-case scenario” before mitigation is applied, and therefore provides an understanding of what may happen if mitigation fails or is not as effective as predicted. For establishing significance of different impacts, understanding the responses and interaction of the environmental system is essential. Hence, the impact interactions and pathways are to be understood and established first. Such an understanding will help in the assessment process to quantify the impact as accurately as possible. Complex interactions, particularly in the case of certain indirect or cumulative impacts, may give rise to non-linear responses, which are often difficult to understand and therefore their significance is difficult to assess. It is hence understood that indirect or cumulative impacts are more complex than the direct impacts. Currently the impact assessments are limited to direct impacts. In case mitigation measures are delineated before determining significance of the effect, the significance represents the residual effects.

However, the ultimate objective of an EIA is to achieve sustainable development. The development process shall invariably cause some residual impacts even after implementing an EMP effectively. Environmentalists today are faced with a vital, not-easy-to-answer question—“What is the tolerable level of environmental impact within the sustainable development framework?” As such, it has been recognized that every ecosystem has a threshold for absorbing deterioration and a certain capacity for self-regeneration. These thresholds based on concept of carrying capacity are as follows:

- Waste emissions from a project should be within the assimilative capacity of the local environment to absorb without unacceptable degradation of its future waste absorptive capacity or other important services.
- Harvest rates of renewable resource inputs should be within the regenerative capacity of the natural system that generates them; depletion rates of non-renewable inputs should be equal to the rate at which renewable substitutes are developed by human invention and investment.

The aim of this model is to curb over-consumption and unacceptable environmental degradation. But because of limitation in available scientific basis, this definition provides only general guidelines for determining the sustainable use of inputs and outputs. To establish the level of significance for each identified impact, a three-stage analysis may be referred:

- First, an impact is qualified as being either negative or positive.
- Second, the nature of impacts such as direct, indirect, or cumulative is determined using the impact network
- Third, a scale is used to determine the severity of the effect; for example, an impact is of low, medium, or high significance.

It is not sufficient to simply state the significance of the effect. This determination must be justified, coherent and documented, notably by a determination methodology, which must be described in the methodology section of the report. There are many recognized methodologies to determine the significance of effects.

2.9.1 Criteria/methodology to determine the significance of the identified impacts

The criteria can be determined by answering some questions regarding the factors affecting the significance. This will help the EIA stake-holders, the practitioner in particular, to determine the significance of the identified impacts eventually. Typical examples of such factors include the following:

- Exceeding threshold limit: Significance may increase if a threshold is exceeded. e.g., particulate matter emissions exceed the permissible threshold.
- Effectiveness of mitigation: Significance may increase as the effectiveness of mitigation measures decreases. e.g., control technologies, which may not assure consistent compliance to the requirements.
- Size of study area: Significance may increase as the zone of effects increases.
- Incremental contribution of effects from action under review: Significance may increase as the relative contribution of an action increases.
- Relative contribution of effects of other actions: Significance may decrease as the significance of nearby larger actions increase.
- Relative rarity of species: Significance may increase as species becomes increasingly rare or threatened.
- Significance of local effects: Significance may increase as the significance of local effects is high.
- Magnitude of change relative to natural background variability: Significance may decrease if effects are within natural assimilative capacity or variability.
- Creation of induced actions: Significance may increase as induced activities also highly significant.
- Degree of existing disturbance: Significance may increase if the surrounding environment is pristine.
- vulnerability and likely risk associated with project activity on population, employs and environmental media particularly with regard to pollutants like mercury and chlorine, HAP emission from chlor-alkali industry

For determining significance of impacts, it is important to remember that secondary and higher order effects can also occur as a result of a primary interaction between a project activity and the local environment. Wherever a primary effect is identified, the practitioner should always think if secondary or tertiary effects on other aspects of the environment could also arise.

The EIA should also consider the effects that could arise from the project due to induced developments, which take place as a consequence of the project. Ex. Population density and associated infrastructure and jobs for people attracted to the area by the project. It also requires consideration of cumulative effects that could arise from a combination of the effects due to other projects with those of other existing or planned developments in the surrounding area. So the necessity to formulate a qualitative checklist is suggested to test significance, in general.

3. ABOUT CHLOR-ALKALI INDUSTRY INCLUDING PROCESS AND POLLUTION CONTROL TECHNOLOGIES

3.1 Introduction

The chlor-alkali industry produces a range of chemicals such as chlorine (Cl_2), alkali, sodium hydroxide (NaOH) or potassium hydroxide (KOH), by electrolysis of a salt solution and currently 95% of world chlorine production is by this industry. In fact, the inevitable co-production of chlorine and NaOH in almost equal amounts has always been a problem for the chlor-alkali industry. Both products are used for very different end uses with differing market dynamics and it is only by rare chance that demand for the two coincides.

Chlorine is largely used in the synthesis of chlorinated organic compounds. Vinyl chloride monomer (VCM) for the synthesis of polyvinyl chloride (PVC) still remains the driver of chlor-alkali production in the world. But economical storage and transport of chlorine is difficult and it is therefore production is sited in close proximity to the consumers.

NaOH is usually supplied as a 50% aqueous solution and can be stored for long periods and readily transported (rail, road and ship). The major industrial users include – chemicals for synthesis of organic or inorganic compounds, metallurgy - alumina/aluminum industry, pulp & paper industry for pulp production, textile industry for bleaching, soaps, surfactants, water treatment plants, *etc.* Hydrogen is also a by-product of the electrolysis of brine (28 kg for 1 tonne of chlorine). Hydrogen is generally used on-site as a combustible gas or sent as a fuel to other companies. It can also be used in integrated sites for certain applications, in particular, because of its high purity *i.e.*, synthesis of ammonia, methanol, hydrochloric acid, hydrogen peroxide, *etc.*

Different applications of chlorine and caustic soda are as follows:

- Production of metals and resource materials: Alumina, propylene oxide, polycarbonate resin, epoxies, synthetic fibres, soaps, detergents, rayon, *etc*
- Pulp & paper industry: Caustic soda is used for pulping wood chips. Chlorine and its compounds are used to bleach wood pulp in the paper production process
- Petroleum and natural gas extraction industry: Caustic soda is used as a drilling fluid
- Manufacture of organic chemicals: Chlorine is used for making ethylene dichloride, glycerine, glycols, chlorinated solvents and chlorinated methanes
- PVC industry: Used for making plastics, most notably PVC, which is being used extensively in building and construction, packaging, and many other items
- Pesticides: 96 per cent (%) of all pesticides are produced using chlorine
- Industrial solvent: A variety of chlorinated compounds are used as industrial solvents, including the main ingredient used in dry cleaning.

- Water treatment: Chlorine is used in 98% of the water treatment plants in the world
- Pharmaceuticals: 85% of all pharmaceuticals use chlorine at some point in the production process
- Other relevant applications: Domestic bleaches, flame-retardants, food additives, refrigerants, insulation, computer chip manufacturing and hospital disinfectants among others

3.1.1 Production & demand of chlorine

Chlorine production of a country is said to be the indicator to evaluate the developmental status of its chemical industry. Chlorine production in India has risen enormously during the post-independence time, owing to the burgeoning demand for various products requiring Cl₂, for the manufacturing of other products like PVC and polyurethanes. The production of chloroaromatics (*e.g.* chlorobenzene for phenol synthesis), propylene oxide (chlorohydrin process), solvents containing chlorinated hydrocarbons, and inorganic chlorine compounds are also important factors behind the increased use of chlorine after 1950.

Major share of chlorine produced globally is used in the manufacture of organic chemicals including VCM, ethylene dichloride, glycerine, glycols, chlorinated solvents, and chlorinated methanes. Vinyl chloride used in the production of PVC and many other organic chemicals, accounts for one-third of the total chlorine production. Other major consumers are pulp & paper industry, industries producing other inorganic chemicals, disinfection treatment of water and the production of hypochlorites. While more than two-thirds of global production of chlorine is consumed in the same manufacturing plant for production of other chemical intermediates, two-thirds of total chlorine produced in India is sold.

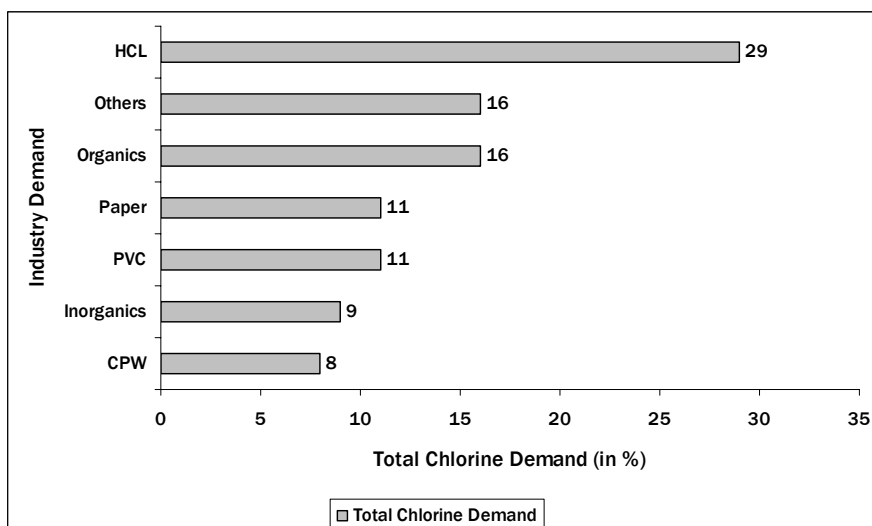

Figure 3-1: Global Consumption Pattern of Chlorine (in percentage)

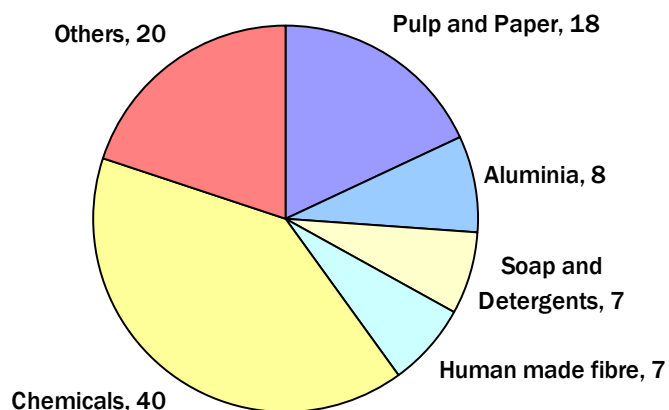

Figure 3-2: Global Consumption Pattern of Caustic Soda (in percentage)

Both chlorine and caustic soda are demand in Indian markets. Though Indian companies have chlorine in excess, they cannot export it simply because of the major hazards associated with transportation of chlorine. Chlorine also finds a place in the list of toxic and hazardous substances banned for trans-national transportation under the Basel Convention on hazardous wastes. As a result, India is faced with double-trouble– on one hand, it has to deal with the growing chlorine stock that cannot be disposed off while on the other, the dumping of caustic soda is forcing the sector to compete with low international prices. This is unviable for the sector as its production costs are high.

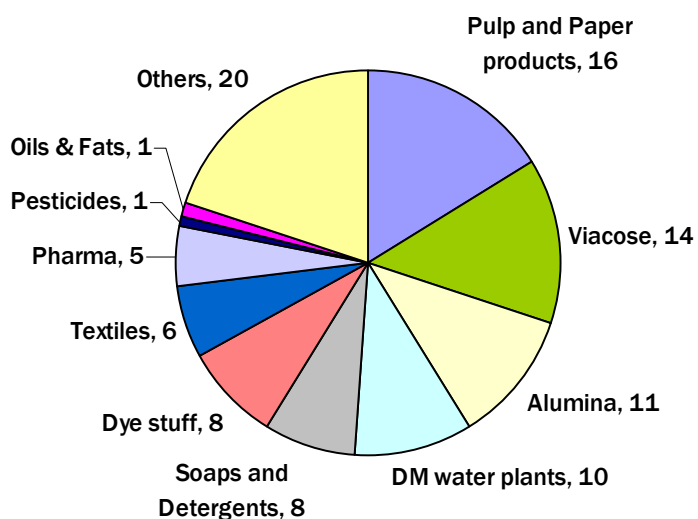

Figure 3-3: Caustic Soda Demand in India (in percentage)

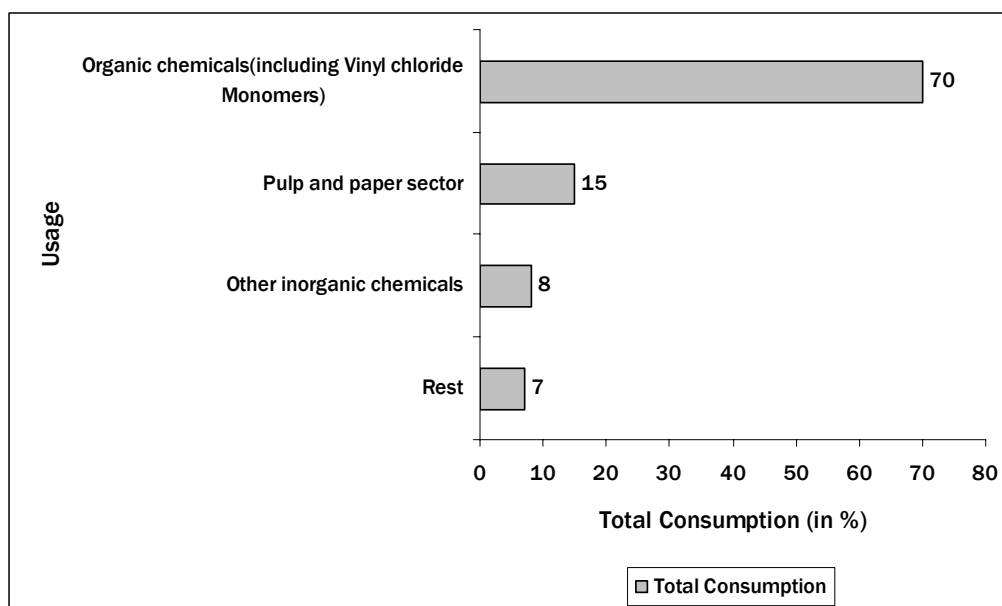

Figure 3-4: Chlorine Demand in India

Chlor-alkali industry in India is around 60 years old. It began with a modest capacity of a few thousand tonnes per annum (TPA) and has now grown into 29.23 lakh TPA (2008-09) capacity industry. The domestic consumption of caustic soda during the year 2008-09 was around 23.17 lakh tonnes.

There are:

- Thirty seven units (2008-09) in India manufacturing caustic soda, chlorine and associated products
- Thirty three units with membrane cell process (MBCP)
- Four units with using combined technologies of mercury cell process (MRCP) and MBCP. The process accounts for 93% of total production and 7% are constituted by MRCP during the year 2008-09.

In India, at present diaphragm process for the production of caustic soda and chlorine are not in operation. Last MRCP commissioned was during 1984 and since 1986 no new MRCP was installed as Government does not encourage setting up of plant based on mercury cell. Because of such policy, energy demand and environmental problem, a shift in technology has taken place in India and at present about 95% of total installed capacity for caustic soda production is based on membrane cell technology, which is more energy efficient and does not use any raw material as hazardous chemical in the process.

3.1.2 Shift towards membrane technology in India

Increasing environmental awareness, especially with respect to (w.r.t) mercury pollution has begun a new era of change in the chlor-alkali manufacturing process.

Indian Government's mandate imposed in 1986 ruled out further establishment of MRCP-based plants leaving the caustic-chlorine plants with a singular choice of MBCP technology. This regulatory intervention has expedited the eventual shift from MRCP to MBCP. While in 1960s and 1970s, most of the companies were using mercury or

diaphragm cell technology, today in India, 90% of companies use MBCP. There are still 10% of plants using MRCP.

Capacity of caustic-chlorine sector increased substantially in 1990s when some big companies were set up using MBCP like Indian Petrochemicals Corporation Ltd, Reliance Industries, Shriram Alkalis & Chemicals Ltd, *etc.* In addition, number of companies earlier using mercury cells changed to membrane during 1990s such as NRC Ltd – Chemical Division, Punjab Alkalies & Chemicals Ltd, Grasim Industries Ltd, *etc.* The membrane technology has advantage over MRCP in terms of absence of mercury pollution and energy efficiency.

In India the caustic-chlorine industry has been shifting towards cleaner manufacturing process from the traditional MRCP which is most hazardous process. More than 70% of the sector uses the eco-efficient option of MBCP technology. Compared to Europe and the US, where more companies are still using the polluting MRCP and diaphragm cell technologies respectively, the effort of the Indian caustic-chlorine sector in moving towards MBCP technology is a truly global benchmark. The energy consumed by Indian caustic-chlorine industry is probably the least in the world and their consumption efficiency too rivals the global best performance.

The membrane cell process is the preferred process for new plants. Diaphragm processes may be acceptable, in some circumstances, if non-asbestos diaphragms are used. The energy consumption in a MBCP is of the order of 2,200–2,500 kilowatt-hours per metric tonne(kWh/t), as against 2,400–2,700 kWh/t of chlorine for a diaphragm cell process.

However, the biggest challenge that the MRCP technology faces is the reduction of mercury pollution. Currently Indian companies which are few in numbers consume relatively more mercury than the European plants and therefore such Indian industries should follow the mercury reduction programme or shift to MBCP technology.

3.2 Scientific Aspects

As described in the previous sections, chlorine and caustic soda are the two basic products of chlor-alkali industry which are widely used in diverse industrial sectors, either as raw materials or as auxiliary chemicals to produce a variety of products.

Chlorine and caustic solution (sodium or potassium hydroxide) are produced simultaneously by means of decomposition of a salt solution in water. Along with chlorine and caustic solution, hydrogen is produced. The raw materials used in the process are NaCl or KCl, water, electricity, *etc.* Most of the time, NaCl is used in the process as a raw material and less frequently KCl. Other processes such as the electrolysis of hydrochloric acid (HCl) or the electrolysis of molten NaCl are also applied, but rarely.

In all processes, the NaCl is dissolved in water:

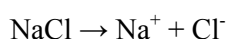

The overall process is based on reaction:



Table 3-1: Reactions

Stoichiometric Amount							
Salt	+	Water	=	Caustic Soda	+	Chlorine	+ Hydrogen
NaCl		(H ₂ O)		(NaOH)		(1/2 Cl ₂)	(1/2 H ₂)
58.5 g		18 g		40 g		35.5 g	1 g

The basic principle in the electrolysis of NaCl solution is the following:

▪ **At the anode:**

- chloride ions are oxidized and chlorine (Cl₂) is formed based on the following reactions:

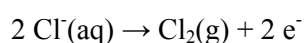

▪ **At the cathode:**

- In the mercury process, a sodium/mercury amalgam is formed and hydrogen (H₂) and hydroxide ions (OH⁻) are formed by the reaction of the sodium in the amalgam with water in the denuder. The cathode reaction is:

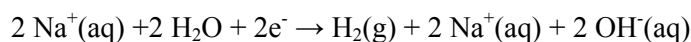

- In membrane and diaphragm cells, water decomposes to form Hydrogen (H₂) and hydroxide ions (OH⁻) at the cathode.

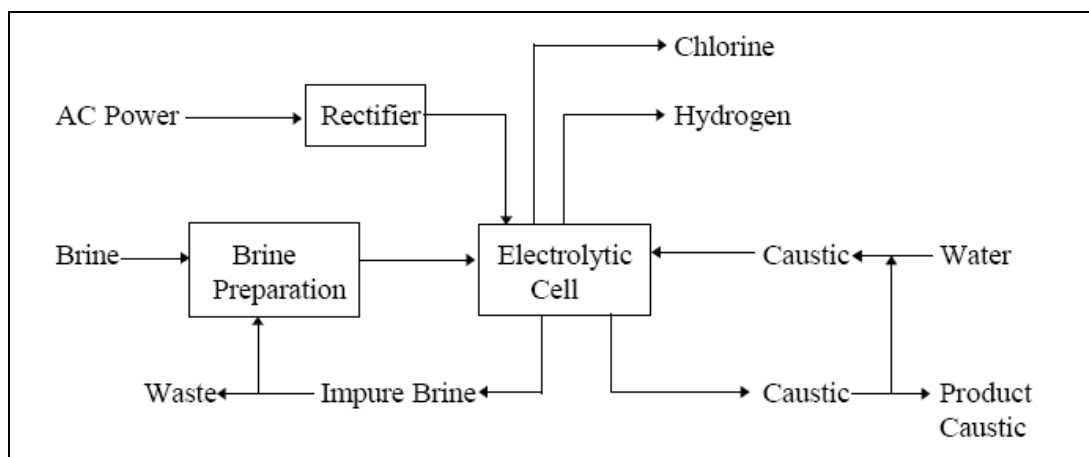

Figure 3-5: Chlor-alkali Plant Scheme

Caustic soda and Hydrogen are produced in – more or less – a fixed ratio, independent of the technology used:

Per 1 tonne of chlorine produced:

- 1128 kg of NaOH (100 %) is produced if NaCl is used as the raw material
- 1577 kg of KOH (100%) is produced if KCl is used as the raw material (the molecular weight of KOH is higher than that of NaOH)
- 28 kg of hydrogen is produced

Product description

1. Chlorine cannot exist naturally by itself because it is highly reactive and one of the most plentiful elements in the world. Most chemical processes require it for synthesis, which is why it is often produced at the industrial sites producing chemicals, pharmaceuticals and/or Pulp & Paper mills. Chlorine, thus produced onsite, can be easily distributed by pipeline for long-term provision to the other processing companies. It is used in all industries, in household-solvents, pharmaceuticals, water treatment plants, plastics, acids and many more.
2. Caustic soda (NaOH) is a versatile alkali and is used as a reactant in the manufacturing of various sodium compounds. For example, it is used to produce sodium hypochlorite, which in turn is used in production of various bleaches and disinfectants. Caustic soda is used in many industries, for control of pH, to breakdown cellulose, in cleaning operations, *etc.* The main industries, where it is used are rayon, cellophane, soap, and pulp & paper.
3. Because of its high-energy non-toxic nature, hydrogen can be used in many processes. Hydrogen produced from MRCP contains traces of mercury, which may disperse into the environment through its use in different products. Hence, the hydrogen from MRCP requires treatment for removal of mercury.

3.2.1 Industrial processes

The three basic processes for the electrolytic production of chlorine and caustic soda are (a) MRCP, (b) the diaphragm cell process (DCP), and (c) MBCP. MBCP is the most modern and has economic and environmental advantages. The two other processes generate hazardous wastes (containing mercury or asbestos). Each process differs in keeping chlorine produced at the anode separate from the caustic soda and hydrogen produced, directly or indirectly, at the cathode.

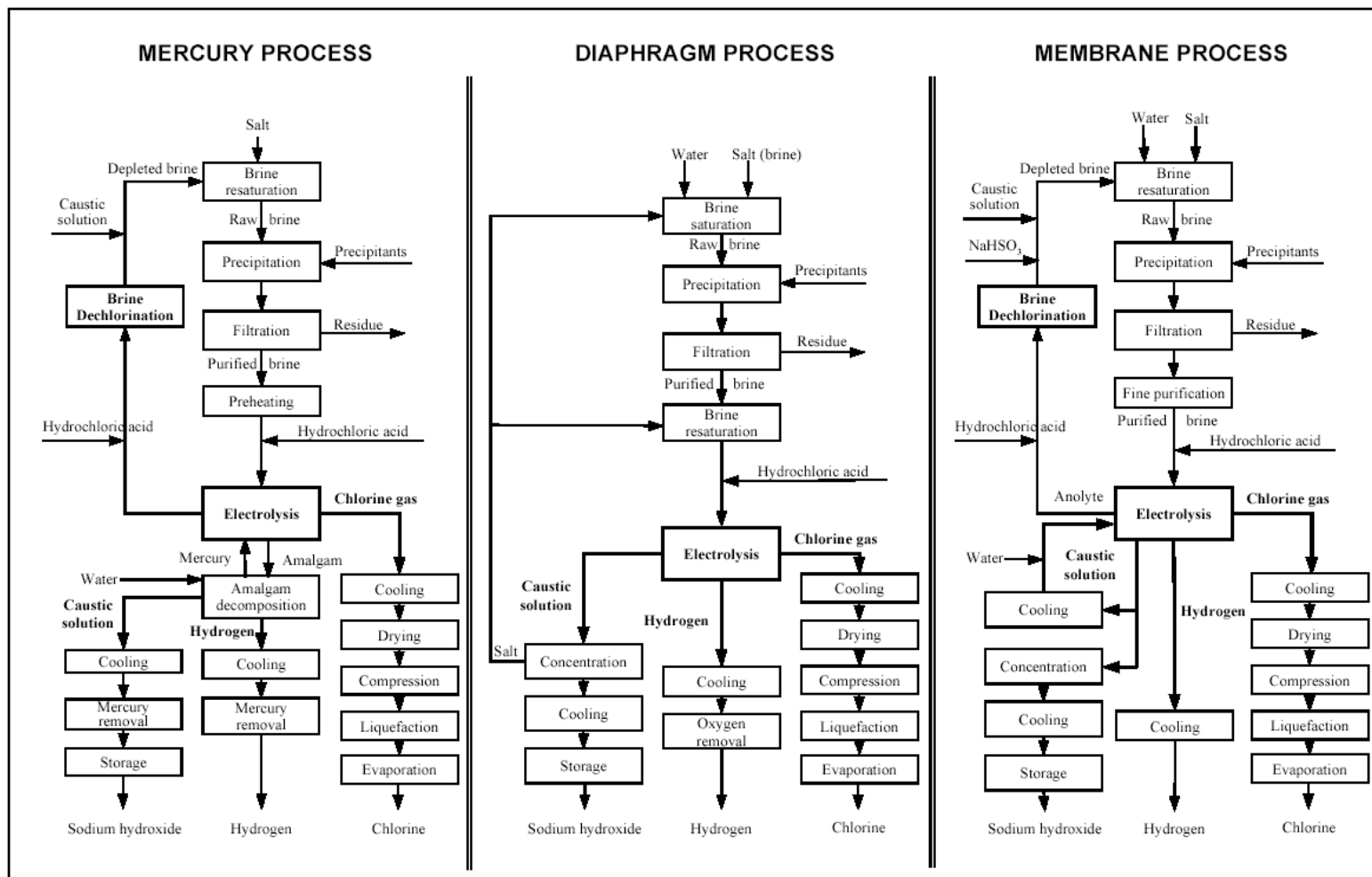

Figure 3-6: Flow Diagram of the Three Main Chlor-Alkali Processes

3.2.1.1 MRCP

MRCP involves two cells. In the primary electrolyser (or brine cell), purified and saturated brine containing approximately 25% NaCl flows. In the bottom of this trough a shallow film of mercury (Hg) flows (as cathode) along the brine cell co-currently with the brine as cathode where as an anode assembly is closely suspended as shown under:

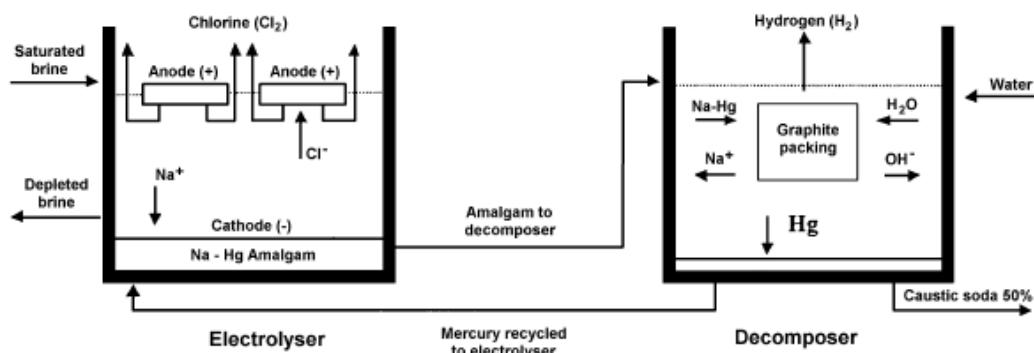

Figure 3-7: Simplified Scheme of Mercury Electrolysis Cells

The cathode is made by a shallow layer of mercury which flows from one extremity of the cell to the other because the cell is made of an elongated, slightly inclined trough and a gas-tight cover. The trough is made of steel, and its sides are lined with a protective, non-conductive coating to prevent contact with the anolyte, to confine brine-cathode contact to the mercury surface, and to avoid the corrosive action of the electrolyte. The steel base is made as smooth as possible to ensure mercury flow in an unbroken film. In the event of a break in the mercury surface, caustic soda will be formed on the bare (steel) cathode, with simultaneous release of hydrogen, which will mix with the chlorine. Because hydrogen and chlorine can form a highly explosive mixture, great care is necessary to prevent hydrogen formation in the cell. Besides, the whole electrolyser is required to be insulated from the floor to prevent stray ground currents.

Usually, several electrolyzers are placed in series by electric connections between the cathode of one electrolyser and the anode of the next electrolyser. Individual cells can be by-passed for maintenance and replacement.

The decomposer is a short-circuited electrical cell in an electrolytic sodium hydroxide solution. This cell has the sodium amalgam as the anode and graphite or metal as the cathode. Water added to the decomposer reacts with the sodium amalgam to produce elemental mercury, sodium hydroxide and hydrogen gas (a by-product). The mercury, stripped of sodium, is re-circulated to the cell through the inlet end box. The caustic soda solution typically leaves the decomposer at a concentration of 50% (by weight) and is filtered and further concentrated by evaporation. The by-product hydrogen gas may be vented to the atmosphere, burned as a fuel, or used as a feed material for other processes.

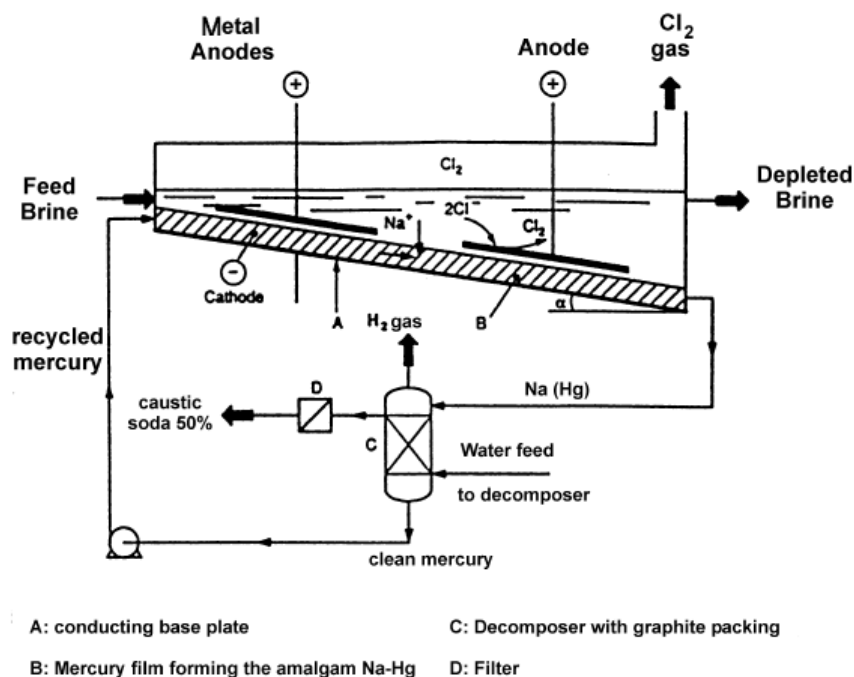
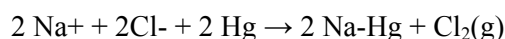
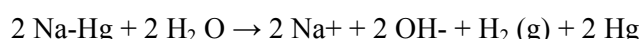

Figure 3-8: MRCP Structural Layout

As chlorine is liberated at the surface of the mercury cathode, the sodium immediately forms an amalgam. The concentration of the amalgam is maintained at 0.2-0.4% Na (by weight) so that the amalgam flows freely. A portion, or in some cases all, of the depleted brine is subsequently dechlorinated, re-saturated with solid salt, and returned to the cell as the brine feed. Some facilities purge small amounts of brine solution and use new brine as make up in order to prevent the build up of impurities, mainly soleplate, in the brine. Mercury cells are usually operated to maintain a 21-22% (by weight) concentration of salt in the spent brine discharged from the electrolyser. This corresponds to the decomposition of 15-16% of the salt during a single pass. Further salt decomposition to a lower concentration in the brine would decrease brine conductivity, with the attendant loss of electrical efficiency. The brine anolyte leaving the cell is saturated with chlorine and must be dechlorinated before it is returned to the dissolvers. The reaction in the electrolyser is:



The liquid amalgam flows from the electrolytic cell to a separate reactor, called the decomposer or denuder, where it reacts with water in the presence of a graphite catalyst to form sodium hydroxide and hydrogen gas. The sodium-free mercury is fed back into the electrolyser and reused. The reaction in the decomposer is:



The sodium hydroxide is produced from the denuder at a concentration of about 50%; the maximum value reported is 73% where as in practice it is much less.

For its operation, the mercury cell depends upon the higher over potential of hydrogen versus mercury to achieve the preferential release of sodium rather than hydrogen. However, impurities that can appear on the mercury surface may lack this over voltage protection and can cause localized release of hydrogen into the chlorine (hydrogen can

form an explosive mixture (>4% H₂) in chlorine or air. The presence of even trace amounts of certain metals, such as vanadium, can cause the release of dangerous amounts of hydrogen. The characteristics of MRCP are tabulated below:

Table 3-2: MRCP Characteristics

Parameters	MRCP Characteristics
Caustic quality	High, <30 ppm NaCl 5-150 µg Hg/l (Before treatment the Hg level is between 2.5-25 mg Hg/l)
Caustic concentration	50%
Chlorine quality	Contains low levels of oxygen (< 0.1%) and hydrogen
Brine feedstock	Some purification required but depends on purity of salt or brine used
Variable electric load performance	Good variable electricity load performance, down to 30 % of full load possible for some cell rooms, which is very important in some European countries

Mercury is not ‘used up’ in the MRCP manufacturing process. It is used only to conduct an electric current. Replenishment is only necessary when mercury leaks into the plant or the surrounding environment or when it leaves the plant in the form of waste or residue. Ideally, facilities would report all loss of mercury through products, air, water, soil and waste that leaves the plant. In practice, however, facilities routinely report buying and adding much more replenishment mercury to the process than they report as releases. A recent report in the USA examined discrepancies between purchasing data and emissions reports, and quantities known to be in products (*i.e.*, mass balance calculations that track mercury within the sector).

3.2.1.2 Diaphragm cell process

The difference between MRCP and DCP is that, in DCP all reactions take place within one cell and the cell effluent contains both salt and caustic soda. A diaphragm is employed to separate the chlorine liberated at the anode, and the hydrogen and caustic soda produced directly at the cathode.

Without the diaphragm to isolate them, the hydrogen and chlorine would spontaneously ignite and the caustic soda and chlorine would react to form sodium hypochlorite (NaOCl), with further reaction to produce sodium chlorate (NaClO₃). When using asbestos diaphragms, the diaphragm process inherently releases asbestos into the surrounding environment.

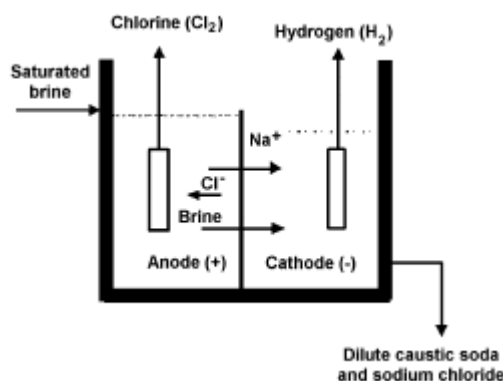

Figure 3-9: Simplified Scheme of Diaphragm Electrolysis Cells

Diaphragm cells have the advantage of operating at a lower voltage than mercury cells. On the other hand, DCP can be operated with brine of lesser purity than required by the membrane cells.

Table 3-3: DCP Characteristics

Parameters	DCP Characteristics
Caustic quality	1.0-1.5% by weight NaCl (Before treatment the NaCl content is about 18%) 0.1% NaClO ₃ Not suitable for some applications
Caustic concentration	12%, requires concentration to 50% for some applications
Chlorine quality	Oxygen content between 1.5-2.5%
Brine feedstock	Some purification required but depends on purity of salt or brine used
Variable electric load performance	Tolerates only slight variation in electricity load and brine flows in order to maintain diaphragm performance

Usage of MBCP and DCP for the production of chlorine and sodium hydroxide may be classified as either monopolar or bipolar. The monopolar electrolyzers are most common and are assembled so that the anodes and cathodes are arranged in parallel. Bipolar electrolyzers, on the other hand, are assembled in series and have unit assemblies of the anode of one cell unit directly connected to the cathode of the next cell unit, thus minimizing inter-cell voltage loss.

The diaphragms of DCP were earlier made of asbestos. However, development of non-asbestos diaphragms had begun in the middle of 1980s which uses an asbestos-free material – fluorocarbon polymer, mainly polytetrafluoroethylene (PTFE).

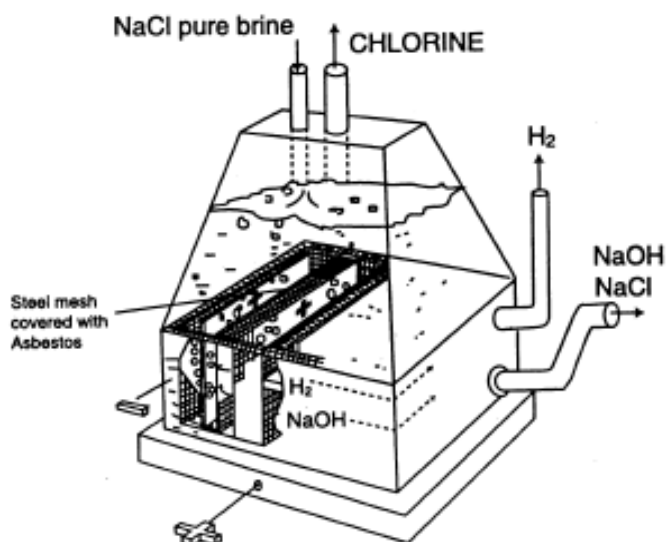

Figure 3-10: DCP Scheme

3.2.1.3 MBCP

MBCP is the most promising and fast-developing technique for the production of chlor-alkali and it has replaced the other two techniques.

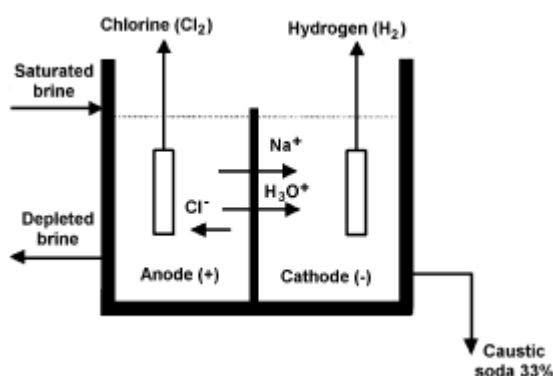

Figure 3-11: Simplified Scheme of Membrane Electrolysis Cells

In this process, the anode and cathode are separated by a water-impermeable ion-conducting membrane. Brine flows through the anode compartment where chloride ions are oxidized to chlorine gas. The sodium ions migrate through the membrane to the cathode compartment which contains flowing caustic soda solution. The demineralized water added to the catholyte circuit is hydrolysed, releasing hydrogen gas and hydroxide ions. The sodium and hydroxide ions combine to produce caustic soda. The membrane prevents the migration of chloride ions from the anode compartment to the cathode compartment. Therefore, the caustic soda solution produced does not contain salt as in the DCP. Depleted brine is discharged from the anode compartment and re-saturated with salt.

The membranes (consisting of two to three layers) used in the chlor-alkali industry are commonly made of perfluorinated polymers with substituted carboxylic groups and is adjacent to the cathodic side. Where as, the other layer are made of perfluorinated polymer with substituted sulphonic groups and is adjacent to the anodic side. To give the

membrane mechanical strength, the membrane is generally reinforced with PTFE fibres. The general economic lifetime of chlor-alkali membranes may range between 2-5 years. Membrane cells have the advantage of producing a very pure caustic soda solution and of using less electricity than the other processes. In addition, the membrane process does not use highly toxic materials such as mercury and asbestos. However, the disadvantages of MBCP are that the caustic soda produced may need to be evaporated to increase concentration and, for some applications, the chlorine gas produced needs to be processed to remove oxygen. Furthermore, the brine entering a membrane cell must be of a very high purity, which often requires costly additional purification steps prior to electrolysis.

Table 3-4: MBCP Characteristics

Parameters	MBCP Characteristics
Caustic quality	High, <50 ppm NaCl
Caustic concentration	33%, requires concentration to 50% for some applications
Chlorine quality	Oxygen content between 0.5% and 2%, depending on whether an acidified electrolyte is used
Brine feedstock	Very high purity brine is required as impurities affect membrane performance
Variable electric load performance	Variable electricity load performance less than for mercury (40-60% depending on design load), affects product quality, and efficiency at lower loads

3.2.1.4 Comparison of the three processes

Pollution from Mercury and poly-chlorinated dibenzo-p-dioxins and dibenzofurans (PCDD/Fs) released from the chlor-alkali plants engaging MRCP and DCP techniques has been a cause of environmental concern since 1950s. Inorganic mercury, thus released into the environment, is metabolized to form highly toxic methyl mercury by anaerobic bacteria, and this organic mercury is bio-accumulated in the food chain. According to Euro Chlor, the total mercury emission to air, water and products from chlor-alkali plants in Western Europe was 9.5 tonnes in 1998, ranging between 0.2-3.0 g Hg/tonne of chlorine capacity at the individual plants.

DCP technology a slightly better alternative to the MRCP, also poses a serious environmental concern because of the asbestos emissions from DCP and the potential exposure of employees to asbestos and its releases to the environment. The use of good practices is the replacement of asbestos with other diaphragm material. DCP can be acceptable, in some circumstances, if non-asbestos diaphragms are used. The energy consumption in a membrane cell process is of the order of 2,200–2,500 kilowatt-hours per metric tonne(kWh/t), as against 2,400–2,700 kWh/t of chlorine for a DCP. These two processes generate hazardous wastes containing mercury or asbestos. Non-asbestos diaphragm technology can also be considered as BAT.

In comparison to the above two, MBCP scores a bit high as it is the most modern technique which has economic and environmental advantages. In MBCP, chlorine (at the anode) and hydrogen (at the cathode) are separated by a selective polymer membrane that allows sodium ions to pass into the cathodic compartment and react with the hydroxyl ions to form caustic soda. The depleted brine is dechlorinated and recycled to the input stage. MBCP is the preferred process for new plants.

The BREF mentions that energy requirement in MRCP is around 3600 kWh/tonne of chlorine gas produced, whereas for MBCP the energy requirement is around 3000 kWh/tonne chlorine. Therefore, in addition to the need to shift to mercury-free technology in terms of emissions, in order to minimize its energy requirements, industry would need to convert to MBCP.

The MRCP also has an advantage over diaphragm and membrane cells that the chlorine gas produced thus has nearly no oxygen, and a 50% caustic soda solution. However, MRCP operates at a higher voltage than DCP and MBCP. MRCP also requires a pure brine solution with little or no metal contaminants to avoid the risk of explosion through hydrogen generation in the cell.

3.2.2 Auxiliary processes

There are various auxiliary processes attached to all the three technologies, which are listed below:

- salt processing; unloading/storage
- brine purification and re-saturation
- chlorine processing
- caustic processing
- hydrogen processing

(i) Salt processing – unloading/storage

Rock salt, solar salt, or vacuum-evaporated salt from purifying and evaporating solution-mined brine are the basic raw material. Because of MBCP's high-purity-need, the salt is stored in a sealed area equipped with a roof. The composition of purified brine is: Ca: <2 mg/l, Mg: <1 mg/l, SO₄: <5 g/l. The brine purification process is needed to avoid any undesirable components (sulphate anions, cations of Ca, Mg, Ba and metals) that can affect the electrolysis. The quality of the raw material and the brine quality requirements for each of the three technologies determine the complexity of the brine treatment unit.

The brine purification is a two-stage process. The first stage of purification uses sodium carbonate and sodium hydroxide to precipitate calcium and magnesium ions as calcium carbonate (CaCO₃) and magnesium hydroxide [Mg(OH)₂]. Metals (iron, titanium, molybdenum, nickel, chromium, vanadium, tungsten) may also precipitate as hydroxide during this operation. The precipitated impurities are then removed by sedimentation, filtration or a combination of both. The second stage of brine purification consists of a polish filtration step and brine softening in an ion exchange unit. The ion exchange resin is periodically regenerated with high-purity hydrochloric acid and sodium hydroxide solutions.

Besides, the brine may also contain ammonium ions or organic nitrogen due to salt and/or water impurities which are converted to nitrogen trichloride (NCl₃) in the electrolytic cell. If concentrated, NCl₃ may explode with disastrous results. For destroying this ammonium salt impurity, chlorination at a pH higher than 8.5 or hypochlorite treatment is required.

Salt storage and brine purification unit requires proper management to avoid salt percolation to groundwater. Concrete flooring around this area, collection and reuse/recycling of salt laden water may be practiced.

(ii) Brine re-saturation and dechlorination

Membrane technology usually operates with brine recirculation and re-saturation where in the depleted brine leaving the electrolyzers is first dechlorinated because the active chlorine can damage the ion exchange resins of the secondary brine purification unit.

To achieve this, the brine is sent to an air-blown, packed column or is sprayed into a vacuum system to extract the major part of the dissolved chlorine. Then further to eliminate the chlorine completely the brine is passed through an activated carbon bed or by injection of a reducing agent (*e.g.* sulphite).

(iii) Chlorine production, storage and handling

Generally, before Chlorine can be stored and supplied for end use, it goes through a series of processes for cooling, cleaning, drying, compression and liquefaction. In some applications, it can be used as a dry gas without need for liquefaction. A general flow of chlorine from the electrolyzers to storage is presented in Figure 3-12.

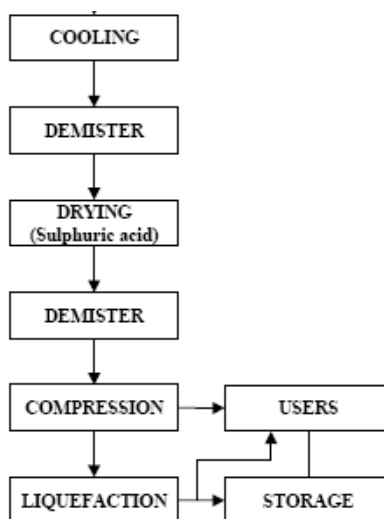

Figure 3-12: Flow Scheme of Chlorine Gas Treatment

Finally chlorine is liquefied and stored at ambient or low temperature. However, because of the high-toxicity of chlorine, the storage area must be carefully monitored and special care must be taken during loading/unloading operations.

Chlorine is highly reactive and oxidizing in nature. It undergoes hydrolysis when it comes in contact with moisture present in atmosphere. As a result, it is converted into HCl and hydrochlorous acid which are harmful to vegetation. Chlorine gas causes serious health problems related to respiratory system. Sources of chlorine emissions are in the chlor-alkali industry process are:

- Cl₂ transfer from one vessel to another
- cleaning of Cl₂ tankers/cylinders
- improper treatment of spent brine
- leakage of sniff (un-liquefiable) gas line
- lime exhaustion in bleach liquor plant (absorption tower)
- failure of Cl₂ compressor and or suction device

- tripping of pumps and leakage of chlorine from pump glands, flange joints, corroded pipes & valves, *etc.*

Proper monitoring, control and safety measures are required in these areas to prevent fugitive emissions and excess release of chlorine gas. Safety measures are also required to be in place for chlorine in chlorine-handling section and also during its transportation. However, in events of any serious leak, an on-site emergency preparedness plan is required..

Chlorine liquefaction

Liquefaction can be accomplished at different pressure and temperature levels, at ambient temperature and high pressure (for example 18 °C and 7-12 bar), at low temperature and low pressure (for example - 35 °C and 1 bar) or any other intermediate combination of temperature and pressure. The chosen liquefaction pressure and temperature influence the choice of cooling media and the safety precautions necessary to operate safely. However, the efficiency of liquefaction is limited because hydrogen is concentrated in the residual gas and its concentration needs to be kept below the explosive limits.

Impurities in chlorine gas

Chlorine gas from the electrolysis cells may contain impurities such as NCl_3 , Br_2 , $\text{C}_x\text{H}_y\text{X}_z$, CO_2 , O_2 , N_2 and H_2 . First three impurities predominantly dissolve in liquid chlorine, whereas the non-condensable gases such as CO_2 , O_2 , N_2 , and H_2 remain in the gas phase and increase in concentration during chlorine liquefaction. Traces of sulphuric acid, ferric sulphate, ferric chloride and/or carbon tetrachloride might also be present in the gas phase after drying and liquefaction of chlorine. These impurities in the tail-gas should be treated based on the following processes:

Tail-gas treatment

Air dilution and production of weak NaOCl: By diluting the remaining chlorine tail gas with air, the concentration of hydrogen can be kept below the explosion limit. The remaining gases after liquefaction have to be purged as it still contains a significant amount of chlorine, and the gas is therefore normally led to the chlorine destruction/absorption unit.

Production of hydrochloric acid: Instead of diluting the remaining gases after partial condensation of the chlorine gas, the hydrogen can be removed from the system by means of a reaction with chlorine gas in a column. This virtually removes all hydrogen and yields gaseous hydrochloric acid, which exists harmlessly with the chlorine gas and can be recovered in a hydrochloric acid unit. The remaining chlorine gas can now safely be condensed further. HCl is a saleable product. It may otherwise be used as feedstock for downstream production, such as ferric chloride.

(iv) Caustic soda – storage and handling

Caustic soda is produced in a fixed ratio of 1.128 tonnes (as 100% NaOH) per tonne of chlorine produced. Caustic soda solution from the diaphragm and membrane technologies is treated in slightly different ways due to the difference in composition and concentration. Caustic soda produced from MRCP contains mercury which can be demercurised through special filtration process.

In case of DCP and MBCP technologies, caustic soda is concentrated by evaporation before final storage. The pure concentrated NaCl produced can then be used to enrich depleted brine. The residual level of NaCl in sodium hydroxide from diaphragm cell is about 1% and sodium chlorate 0.1% and as such is not suitable for manufacture of rayon. Salt and sodium chlorate in the caustic soda from diaphragm cells can be reduced by ammonia extraction to increase marketability, but at an increased cost. The caustic soda from membrane cells is of high quality but of low strength- around 33% NaOH which needs to be concentrated to 50% or 73% NaOH solution and even to 100% as solid caustic prills or flakes for some applications.

As far as storage and handling of caustic soda is concerned, its properties such as high reactivity and corrosive nature should be considered while selecting the construction materials of equipment and tanks. Care should be taken to ensure that the materials is best-suited for storage and handling of caustic soda. Storage tanks may be lined in order to minimize iron contamination of the product or to avoid stress corrosion cracking the tank. It is pertinent to note that dissolved hydrogen gas can be released into the vapour space above the liquid in storage tanks, so testing for an explosive mixture of hydrogen in air should precede any maintenance activity in the area.

Caustic soda thus produced is of rayon grade (48%) but is contaminated with mercury. However, its production by MEB cell process is of low strength (32%) but of high purity required to be concentrated for application. NaOH from MRCP requires to be demercurized before concentration for making flakes (solid caustic) and if H₂ from MRCP is used as fuel in the process of evaporation and concentration, it also requires to be made free from Hg to avoid air pollution problem. Such conditions are to be strictly ensured by the regulatory Authority as consent condition. Majority of caustic soda units in the country produce flakes as solid caustic. Flakes are packed in plastic bags and stored in godown for sale. There is specific requirement for its staking which needs to be followed. Storage and handling of caustic soda (lye) should be given due care as it is a hazardous chemical and is highly corrosive. Therefore, storage tank of lye requires to be properly lined and periodically maintained to avoid iron contamination. The release of dissolved H₂ in the tank should also be minimised to avoid an explosive condition in the tank.

(v) Hydrogen storage and handling

Hydrogen is the major by-product generated (>99.9% by volume) in the ratio of 28 kg per tonne chlorine produced which is required to be cooled to remove water vapour, sodium hydroxide and salt. Only in MRCP technology it is likely to be contaminated with mercury which should be removed after suitable treatment. The solution of condensed salt, water and sodium hydroxide generated in the process can be recycled as brine make up or treated with other wastewater streams.

The hydrogen product gas stream is always kept pressurized to avoid ingress of air but all electrical equipment in the hydrogen plant area must be 'intrinsically safe' from spark.

The hydrogen can be used for in-house or outside energy production after making it free from mercury in case of MRCP. It can also be used by other companies as chemical feedstock (production of hydroxylamines, hydrochloric acid, hydrogen peroxide, sodium sulphite, for example).

As a safety measure, end box ventilation is necessary to remove any chance of formation of explosive mixture of H₂ and air. Industry has (MBCP&MRCP) to take proper care to prevent formation of any explosive conditions in the process.

3.2.3 Raw Material inputs in the production line

Inputs and pollutant outputs of the chlor-alkali industry are quite specific to the cell technology used but also depend on the specifications of the products, the purity of the incoming salt and the geographical location of the plant.

Chemicals

In all the three technologies the raw materials primarily used as feedstock are salt and water. However, there are number of chemicals namely: acids and chemical precipitants used to remove impurities in the input brine or output chlorine/caustic soda; cooling agents (CFCs, HCFCs, HFCs, ammonia, *etc.*) for liquefying and purifying the chlorine gas produced. The DCP and MBCP techniques require replacement of spent materials.

Different types of raw salts are used to produce the brine for electrolysis based on vacuum-crystallized salt from solution-mined brine, rock salt and solar salt. Though, the stoichiometric brine consumption is 1.66 tonnes per tonne of chlorine produced, the actual requirement is 1.75 tonnes per tonne of chlorine produced because of impurities control of the brine by purge.

Besides, the DCP requires to sell salt from caustic evaporators and to buy new feedstock for economic reasons. The consumption of pure brine is about 5 tonnes of salt per tonne of chlorine produced. In case KCl is used instead of NaCl, then the amount of salt needed is about 2.1-2.2 tonnes of salt/tonne of chlorine produced due to the higher molecular weight of KCl.

3.2.3.1 Ancillary materials

Ancillary materials used in various steps of the processes are:

- Chemicals used to remove impurities from the brine are *e.g.* sodium carbonate, barium salts, calcium chloride and sodium hydroxide. Acids are also used, *e.g.* hydrochloric acid is used to adjust the pH of cells and reduce undesirable products in chlorine, sulphuric acid is used for chlorine drying. In cooling water systems, inhibitors are added. Sodium carbonate is used in mercury retorting to react with sulphur compounds as well as sodium hydrosulphide.
- Reducing agents (hydrazine or sulphides) are used to remove mercury in wastewater; flocculants such as ferric chloride and polyaluminium chloride are used for water purification in the wastewater treatment process.

Table 3-5: Inputs per Tonne of Chlorine Produced

	Membrane	Amalgam	Diaphragm	Comments
Raw Materials				
Salt (NaCl)	1750 kg			in theory 1660 kg (no losses)
Water	1-2 m ³			Only Process water

Steam	180 kWh	-	610 kWh	AC, typical use for 50% Caustic
Electricity	2790 kWh	3560 kWh	2970 kWh	AC, typical use, depends on current density
Auxiliaries				
Mercury	-	2.6-10.9 g		
Asbestos	-	-	0.1-0.3 kg	

Water

Water is the major natural resource used for various processing needs as well as for cooling, brine recirculation, *etc.* The chlor-alkali industry needs water for:

- the caustic circuit: for maintaining the water balance in the reaction to form NaOH in the membrane as well as mercury cells
- preparation of the brine
- for purges
- for chlorine absorption unit: the quantity used will depend on the amount of chlorine released to absorption.

Water can also be used for cooling. Apart from the water needed for cooling, generally 2 -2.5 m³ of water is consumed per tonne of chlorine produced for plants using a brine recirculation process. For waste brine processes, about 10 m³ of water per tonne of chlorine produced is required.

Energy

Energy is used both as electricity and as heat. The requirement of huge quantity direct-current (DC) electric power is obtained from a high voltage source of alternating current (AC). The low voltage required for an electrolyser circuit is produced by a series of step-down transformers.

About half of the energy expended is converted into the enthalpy of the products. The rest is converted into heat which is transferred to the air in the building and the products, which have to be cooled. The heat is partly re-circulated through pre-heating of brine. Surplus heat might also be used for heating surrounding buildings or for the concentration of caustic soda. Insulation of the cells and salt dissolvers reduces the need for ventilation of the cell room and increases the amount of heat transferable. The hydrogen produced in chlor-alkali plants can be used as a raw material in the synthesis of chemicals or as a fuel. However, electrical energy use is lower in the membrane technology.

3.2.4 Qualitative and quantitative analysis of pollutants and rejects

MBCP is the most modern technology with economic and environmental advantages is the preferred process for new plants. DCP may be acceptable, in some circumstances, if non-asbestos diaphragms are used.

The DCP facilities established during the last two decades, have been reportedly switching from the use of lead and graphite anodes with asbestos diaphragms to metal anodes and treated diaphragms, which resist corrosion and degradation. The use of lead

and graphite anodes and asbestos diaphragms generate lead, asbestos, and chlorinated hydrocarbons in the caustic soda and chlorine processing waste. Lead salts and chlorinated hydrocarbons were generated from corrosion of the anodes and asbestos particles formed by the degradation of the diaphragm with use. Different regulatory directives concerning asbestos aim to reduce and prevent pollution by asbestos, and to protect human exposure. Under these directives, limits have been set to ensure that the concentration of asbestos discharged into the air or water does not exceed the limits there by compelling the new plants to shift to MBCP.

3.2.4.1 Diaphragm cell process

Air emissions

The primary air pollutants emitted from DCP are asbestos and chlorine (fugitive emissions) from the cells and tail gases from the process. Chlorine is a well-known toxic gas whereas, released dry asbestos fibres (being thin and sharp crystals) can cause serious health problems due to its physical properties. In addition, asbestos is considered to be carcinogenic. The fine fibres are insoluble in body fluids and easily penetrate cell membranes. Three sources of asbestos emission can be identified in the cell room maintenance area:

- from the off-gas compressor
- from the off-gas drying oven
- from the off-gas asbestos weighing room

Fugitive emissions of chlorine gas into the atmosphere are generally low but still the sources of significant potential emission are normally connected with the chlorine destruction unit. Chlorine is a hazardous gas which needs extreme precautions to avoid emissions of chlorine from the process and also from handling and storage.

Wastewater

Water is used for cooling and other process demands. Generally 2-2.5 m³ of water is consumed per tonne of chlorine produced for plants using a brine recirculation process. For waste brine processes, about 10 m³ of water per tonne of chlorine produced is required.

The water used in the DCP plants is released as wastewater streams mainly from the condenser during caustic soda evaporation, chlorine drying, and brine purification of salt recovered from the evaporators.

At the end of the lifetime of an asbestos diaphragm, the asbestos which is removed from the cathode can end up in waste because of high pressure water-jet cleaning. Asbestos is collected with the rinsing water and can be discharged. A filter press can be installed to remove asbestos from the rinsing water. Reported emissions give values of under or equal to 30 mg/l.

Solid Waste

As far as solid waste generation is concerned, the wastes are generated during the brine purification and scraping of cell parts – including cell covers, piping and used

diaphragms. The asbestos diaphragms in modern diaphragm chlor-alkali plants have a lifetime of approximately one year. After this year the cell is taken out of operation and the old asbestos is removed from the cathode can.

3.2.4.2 Membrane cell process

The membrane cell process is the most cleaner technology in comparison to other two processes and emissions from this category of chlor-alkali plants (besides chlorine), are linked to the brine purification needed to avoid undesirable impurities in the membrane cell and solid wastes generated by the used membranes.

Wastewater

Wastewater is generated from cell house, brine purification section, chlorine & hydrogen handling section and HCl manufacturing unit. Membrane plants usually use a bleed from the brine circuit in order to prevent accumulation of contaminants.

For membrane technology, the effluent generated from brine purification is critical for long membrane life and high efficiency. Thus, impurities need to be removed by ion exchange resin units, which then require regeneration with caustic soda and acid washing. Some plants use vacuum crystallized salt, which is the most pure salt form (and also the most expensive) and for this reason, a simplified brine purification step is followed. Brine sludges are one of the largest waste streams of the chlor-alkali industry.

Wastewater from auxiliary units: The source of sulphate in brine is the salt impurity and has a negative effect on the electrolysis process (damages the anode coating). The generation is in the range of 0.3-0.7 kg per tonne of chlorine produced for vacuum salt and about 15 kg per tonne of chlorine produced for rock salt. Besides, high concentration of chlorides is generated in the purge in the range of 4-20 kg/tonne chlorine produced. In addition chloride, bromide, free oxidants, metals, *etc* a range of chlorinated hydrocarbons ($C_xCl_yH_z$) are formed in a reaction between organic contaminants in the electrolyser and free oxidants. Discharges to water ($C_xCl_yH_z$) (measured as EO_x , extractable organic halogens) are typically found in the range of 0.03-1.16 g/tonne of chlorine capacity or even higher from a plant with bleach destruction. Chlorinated hydrocarbons are formed in a reaction between organic contaminants in the electrolyser and free oxidants.

Waste water from sodium or potassium hydroxide processing: NaCl when leaving the electrolytic cell forms the caustic soda with concentration from membrane cells which is 30-33% NaOH with little NaCl. Generally speaking, the caustic soda needs to be concentrated to at least 50% and impurities need to be removed. Wastewater from the membrane process is generated from the caustic evaporators contains caustic soda solution and virtually no salt or sodium sulphates. It is usually recycled.

In membrane and diaphragm cell plants, the filters can be flushed with a weak acid solution, causing the iron hydroxide and metals to dissolve. The effluent is usually discharged, as most chlor-alkali plants have a physical-chemical wastewater treatment unit, which partially removes suspended solids and free oxidants. Three tonnes of sludge from caustic filtration out of a total of 38 tonnes of sludges (the other sources being the brine treatment sludge and the wastewater treatment sludges) produced per year has been reported for one amalgam chlor-alkali plant (chlorine production capacity of 115000 tonnes).

Air emissions

The main gaseous emission as fugitive in the manufacturing of caustic soda is from cell house, processing, and handling & storage units of different products. The emissions are chlorine gas, Mercury and other HAPs which are toxic in nature. As stationary sources, the mercury, chlorine, HCl and Hydrogen are released from hydrogen handling, HCl plant, chlorine absorption unit, cell house and end boxes, *etc.*

Chlorine gas production & handling: Small amounts of carbon dioxide are released from the anode compartment and are collected and treated together with the chlorine and remaining portion is released to atmosphere. Chlorine being a hazardous gas, extreme precaution is essential to mitigate all fugitive emissions from the process and from handling and storage. The sources of significant potential emission are normally connected with the chlorine destruction unit.

When emitted, carbon tetrachloride has GHG implications. The carbon tetrachloride for purification (absorption of tail gas, in particular to absorb NCl_3) and/or liquefaction of chlorine is circulated in a closed loop and hence, the potential of release to atmosphere is very low.

Solid & hazardous waste

Wastes are generated during the brine purification and consist of used materials such, as pre-coat and feed material made of cellulose. The pre-coat filter sludge from the brine softener consists mainly of alpha-cellulose, contaminated with iron hydroxide and silica. Membrane plants report a figure of 600 g/t for sludges from brine softening. Besides, spent membranes and gaskets from membrane cells become waste after their service life. The membranes have a lifetime of between 2 and 4 years.

Brine filtration sludges: The quantity of brine filtration sludges mainly depends on the quality of incoming salt. The precipitated salts used for the purification of the brine are removed from the brine in a filter unit or a clarifier. The sludge is usually removed repeatedly by flushing with a weak hydrochloric acid solution. The acid causes the precipitate to dissolve and the relatively harmless solution joins the other liquid effluent. The remaining solid cake mainly consists of calcium carbonate and magnesium hydroxide, in some cases barium sulphate and, the amalgam process consists of mercury. For plants using vacuum salt, sludges quantity is 120-775 g per tonne of chlorine produced and for plants using rock salt it is as high as, about 30 kg. Brine sludge generated from the chlor-alkali industry is identified as hazardous waste as per the HW(M&H) Rules notified by the Government

Chlorine gas production & handling: Highly concentrated sulphuric acid (92-98%) is used to dry chlorine. Up to 20 kg of sulphuric acid is consumed per tonne of chlorine produced and discarded as spent acid. The spent acid first is to be reduced by process efficiency and the generated quantity can be either recycled to control pH in process and wastewater streams or to destroy surplus hypochlorite or it can be concentrated and sold to a suitable user.

When carbon tetrachloride is used to absorb NCl_3 from the liquid chlorine, the carbon tetrachloride needs to be replaced periodically because of the build up of pollutants (bromine, FeCl_3 , chlorinated hydrocarbons). The removed carbon tetrachloride is either incinerated or sent as hazardous waste.

3.2.5 Exposure pathways

Mercury emissions into the environment are the potential risk posed by mercury exposure due to its persistent nature. In the conversion process of inorganic mercury to organic mercury, mostly methyl mercury by the bacterial action, the most toxic species is bio-accumulative in the biota and subsequently biomagnifies in the aquatic food chain, especially in fish. There is sufficient evidence of significant global adverse impacts of mercury and its compound to warrant national & international action to lower the mercury exposure and reduce its risk to human health and the environment.

The hazardous working conditions and dangerous management practice is still continuing in several industries related to mercury. The atmospheric fall-out of elemental mercury over the soil horizon and its release from water sources in the vicinity of industry were reported to be higher than the control area. The concentration of mercury in blood and hair of human population, in occupationally exposed workers, and people living in the vicinity of industrial location, indicates the level of mercury exposure. The vulnerability and danger of mercury losses and leakage of chlorine during the process and from storage is a constant nightmare to the industry, population, and the environment around it. Serious efforts are needed by caustic chlorine sector in moving towards the membrane technology. However, pollution and contamination arising due to emission of mercury and its entry into food chain via drinking water, air, soil, crops/vegetation, food (fish), etc are the possible pathways of mercury exposure related potential risk to human health and the environment. These receptors are essential to be assessed for risk mitigation arising from pollutant emission e.g. mercury, chlorine, and other hazardous air pollutants particularly from the chlor-alkali industry. It is important from environmental impact assessment angle that regular monitoring of mercury levels in different environmental components and chlorine in the close vicinity of plants is taken up by installing automatic monitoring devices to take corrective measures from time-to-time.

Chlorinated hydrocarbons are not expected from the process and as such the hazardous air pollutants other than chlorine and mercury are not expected as the graphite electrodes are replaced by the titanium metal electrodes.

However, intervention of the Government of India in the form of a rule against the establishment of new chlor-alkali industries in country based on MRCP technology is a step towards the restriction of the human exposure to the mercury. However, the optimization of mercury use in existing mercury-based chlor-alkali industry and associated human exposure is a critical task that needs continuous improvement by voluntary commitment and also through the regulatory provisions. Some of the environmental effects are given in below table.

Table 3-6: Effects of Mercury based plants on the Environment

S. No.	Route	Effects
1	Occupational Hazards	Occupational exposure to elemental Hg vapor is the (work zone) principal hazard to health. Affects liver, kidney, tissue & CNS
2	Water/food	Present in ionic and organic forms. Organic form is more toxic. Hg gets methylated under certain conditions in water, enters human body through food chain, crosses blood brain barrier and retained in brain-causes serious mercury

S. No.	Route	Effects
		poisoning
3	Air	Inhaled Hg vapor is retained in lungs, absorbs in blood stream, gets distributed and deposited in organs showing different symptoms of Hg effects. Highly persistent, bio accumulative, long range air transport , affects flora & fauna and inflicts mutagenic action Level of Hg in hair, blood & urine are the indicators of level of mercury exposures

3.3 Technological Aspects

3.3.1 Natural resource conservation

It includes protection and conservation of aquatic, land, material, food and agricultural resources for socio-economic benefits. Wastewater and other materials which are released during the manufacturing process should be recovered, recycled, and reused to minimize input material *i.e.*, water, raw material, energy requirement in the process. Such practices in chlor-alkali industry conserve resources and in turn reduce pollution through emission of mercury, chlorine, salt, and other material loss. Siting of chlor-alkali industry is a means to conserve fresh water resources *i.e.*, as far as possible restrict siting such industries in fresh water geographical region to avoid deterioration of groundwater due to disposal of high total dissolved solids (TDS) waste. Such industrial site may be more suitable in coastal areas.

The use of hydrogen gas (unutilized one), free-from-mercury, can be used as a fuel to save fossil fuel. Conservation of building, fabric material and agriculture may be given due care. Avoiding chlorine gas leaks in the vicinity of industry may also be taken care of. Adoption of cleaner technologies, which are more energy-efficient, should be encouraged. MBCP is more economical from energy & fossil fuel conservation point-of-view when compared to MRCP and DCP techniques.

3.3.2 Cleaner technologies

Implementation of cleaner processes and pollution prevention measures can yield both economic and environmental benefits.

In MBCP (membrane process), the chlorine (at the anode) and the hydrogen (at the cathode) are kept apart by a selective polymer membrane that allows sodium ions to pass into the cathodic compartment and react with the hydroxyl ions to form caustic soda. The depleted brine is de-chlorinated and recycled to the input stage. The major waste stream from the MBCP consists of brine mud - the sludge from the brine purification step, which may contain magnesium, calcium, iron, and other metal hydroxides, depending on the source and purity of the brine.

3.3.2.1 Pollution prevention technologies

The pollution emission target namely wastewater generation target of 0.1 m³ per tonne of chlorine produced can be achieved by adopting preventive measures such as:

- Having an emergency preparedness and response plan for potential uncontrolled chlorine and other releases.
- Using carbon tetrachloride with levels below 4% to avoid explosion.
- Using metal rather than graphite anodes in DCP to reduce lead and chlorinated organics.
- Re-saturate brine in closed vessels to reduce the generation of salt sprays.
- Use non-contact condensers to reduce the amount of process wastewater.
- Scrub chlorine tail-gases to reduce chlorine discharges and to produce hypochlorite. Scrub chlorine tail-gas using suitable quantity of water for preparation of caustic solution for pH maintenance to reduce chlorine discharge and to produce sodium hypo chloride
- Recycle condensates and waste process water to the brine system, if possible.
- Recycle brine wastes, if possible
- Preferable use of substitutes for carbon tetrachloride as this is hazardous

3.3.2.2 MBCP manufacturing process

For MBCP (membrane technology) the cleaner options include:

- Minimizing the discharge of chlorate and bromate to water by applying: acid conditions in the anolyte (pH:1-2) to minimize the formation of chlorate (ClO_3^-) and bromate (BrO_3^-) – chlorate destruction in the brine circuit to remove chlorate before purging.
- The acidity of the anolyte is a design parameter of membrane cell plants and cannot be adjusted without affecting the operation of the membrane cell. If this is not the chosen option, a chlorate decomposer may be necessary to remove chlorate before purging.
- The chlorate level associated with BAT in the brine circuit is 1-5 g/l and the associated bromate level is 2-10 mg/l (note that the bromate level depends on the bromide level in the salt).
- Appropriate handling of spent membranes and gaskets.

3.3.2.3 New emerging cleaner technologies

A number of new promising techniques are being developed with energy saving as the main driving force. Some of these new techniques for the MBCP and DCP techniques are described below:

- Fundamental research programmes related to mercury technology are not being developed since it is very unlikely that any new mercury plants will be built. The only recent improvements in mercury cells concerns the anode geometry with the aim of improving gas release in order to decrease electrical energy usage and increase anode coating life. In diaphragm technology, with the exception of non-asbestos technology referred earlier, improvements are minor and related to reducing power consumption in the cell. An interesting example is a specific development of activated cathode technology which is the pre-cathode concept.

- Oxygen depolarized cathodes in membrane cells have the potential to save around 500-600 kWh/tonne of chlorine produced and are now being tested at the industrial scale.
- The membrane is being developed that can produce high concentration (50%) caustic soda and believes that it could be available at an acceptable cost within a few years.

3.3.3 Waste minimization opportunities

Complete recycling of mercury-bearing effluent should be done. In order to minimize mercury concentration in the wastewater at 0.01 mg/l, online/automatic mercury monitoring may be put in place to take necessary measures for complete recycling of wastewater or maintaining the effluent requirement. Condensate from cooling of hydrogen and chlorine demister drainage water may be circulated to the brine system to minimize water use. To minimize mercury in brine mud, automatic short-circuiting prevention devices may be placed.

Proper measures may be taken to convert mercury into a soluble complex ion which does not precipitate and also not lost by evaporation. To minimize loss of mercury into air, the floor of the cell room may be provided with epoxy resin for good collection of spilled mercury by vacuum pump. Equipment such as end box, caustic exit of the composer, caustic receiver tank and end box washing water receiving tank should be kept under negative pressure and the resulting gas may be washed in the hypo chloride tower following further treatment by activated carbon/ion-exchange resin. The sludge from different parts contaminated with high-level of mercury should be subjected for mercury recovery by heating and distillation.

3.3.3.1 Shifting from MRCP to MBCP technique

When chlor-alkali plants replace mercury cells with alternative technologies, thousands of tonnes of mercury have to be disposed of as hazardous waste. There is currently no approved disposal method for mercury; only recovery/recycling of mercury is the best option.

The three major pollutants of MRCP air emissions are the (1) by-product hydrogen stream, (2) end box ventilation air and (3) cell room ventilation air.

The by-product hydrogen stream from the decomposer is saturated with mercury vapor and may also contain fine droplets of liquid mercury. The quantity of mercury emitted in the end box ventilation air depends on the degree of mercury saturation and the volumetric flow rate of the air. The amount of mercury in the cell room ventilation air varies widely because of fugitive nature from large number of sources, including, maintenance operations, mercury spills, equipment leaks, cell failure, *etc.* MRCP chlor-alkali facilities should first use pollution prevention methods to minimize fugitive mercury emissions to the environment. Concentrations are to be minimized through practice of good housekeeping methods and equipment maintenance procedures while taking care to keep the worker exposure levels to minimum. Mercury emissions via the cell room air circulation are not subject to specific emission control measures.

The control techniques that are typically used to reduce the level of mercury in the hydrogen streams and in the ventilation stream from the end boxes are these: (1) gas stream cooling, (2) mist eliminators, (3) scrubbers, and (4) adsorption on activated carbon or molecular sieves.

Sulfur and iodine-impregnated carbon adsorption systems are commonly used to reduce the mercury levels in the hydrogen gas stream if high removal efficiencies are desired. This method requires pre-treatment of the gas stream by primary or secondary cooling followed by mist eliminators to remove about 90% of the mercury content of the gas stream. As the gas stream passes through the carbon adsorber, the mercury vapor is initially adsorbed by the carbon and then reacts with sulfur or iodine, to form the corresponding mercury sulfides or iodides.

3.3.4 Pollution control technologies

As far as treatment of waste generated is concerned, the mud generated is normally filtered or settled, where as, the supernatant are recycled, and the mud is dried and land-filled. Chlorine is a highly toxic gas, and strict precautions are necessary to minimize risk to workers and possible fugitive releases during its handling.

There are number of point sources from where mercury emanates through wastewater. These are brine purification units and brine storage tank, cell room washing, cell cleaning & end box washing, mercury spillage during mercury handling and transfer, washing of caustic soda filter, washing of secondary cell components *etc.* Most of the mercury losses can be controlled by good housekeeping and in-plant control measures. The total mercury bearing effluents are to be segregated for cost-effective treatment for removal of mercury. There are a number of techniques used to control mercury emission from wastewater. These are mercury – amalgamation (reduction method, sulphide treatment, ion exchange resin and activated carbon column system for treatment. The ion exchange resin and activated carbon system for de-mercurisation are the most effective and economically feasible control technology, can be either adopted separately or in conjunction with each other to achieve the regulatory norms. This also follows the route of mercury recovery/recycling by chemical means or by heating mercury-laden resin in a retort followed by distillation.

The atmospheric emissions of mercury are from electrolytic cell room and hydrogen venting from hydrogen handling tank. The World Health Organization (WHO) has recommended the concentration of mercury in cell room not to exceed from 0.05 mg per m³ of air. The gas emissions from these sources may be properly collected and cooled following de-mercurisation by activated carbon or ion exchange resin. Mercury vapour is much higher than air and swiftly elutriates, and is carried away long distance by wind and descends on the earth contaminating water, air, land and vegetation and finally gets into mammal. Such heavy metals with high mobility and vapor pressure will try to escape into the environment despite precautions. Mercury vapor in cell room be monitored regularly for remedial action to control Hg loss by adopting the BAT which is practically achievable.

Brine mud demercurisation – during the brine purification addition of sodium hypochlorite (NaOCl) can prevent precipitation of mercury in brine and this reduces the level of mercury in brine sludge to a large extent. The sludge is further treated by sodium hydrochloride followed by vacuum drum filtration. The filtrate containing mercury, if required, may pass through ion exchange resin tower after filtration and removal of insoluble. The treated water can either be taken to brine system or discharge along with the segregated effluent after meeting the regulatory requirement. The use of poor quality salt results in large quantities of brine-mud which poses disposal problem and also groundwater contamination. The brine sludge from chlor-alkali industry is identified as hazardous waste as per HW (M&H) Rules notified by the government. The disposal of brine-mud should be in accordance with the rules and guidelines published by

the government in order to protect the groundwater and air around the disposal/dump site. In case the brine-mud leachate quality contains mercury concentration as per the proposed standards, the sludge is required to be pre-treated before disposal in order to avoid leachate generation and groundwater contamination. The chlor-alkali industry should use good quality of salt to minimize brine sludge generation and also loss of mercury through solid route which is huge (maximum) when compared to other sources. Many industries are using ISI grade salt to reduce loss of salt, as well as mercury.

Caustic soda generated from MRCP contains mercury. It should first be cooled and then filtered through a vertical leaves pre-coat filter (charcoal for removal and treatment of mercury from the product. Hydrogen gas from MRCP should also be cooled to lower the level of mercury content and then be passed through a treatment system comprising activated carbon and ion-exchange resin column.

3.4 Summary of Applicable National Regulations

3.4.1 General description of major statutes

A compilation of legal instruments which are applicable to chlor-alkali industry is annexed as **Annexure I**.

3.4.2 General standards for discharge of environmental pollutants

General standards for discharge of environmental pollutants as per CPCB are given in **Annexure II**.

3.4.3 Industry-specific requirements

Wastewater discharge standard

- Total concentration in mercury in final effluent - 0.01 mg/l
- Mercury bearing wastewater generation (flow) - 10 kilo litres (Kl)/tonne of NaOH production
- pH - 5.5 to 9.0

Guidelines for liquid effluent

- Segregation of mercury-bearing effluent from non-mercury-bearing effluent
- Recycling of mercury-bearing effluent so that not more than 10 Kl of mercury-bearing effluent is generated from each tonne of caustic soda produced
- De-mercurisation of mercury-bearing effluent to bring down the concentration of Hg in the final effluent to < 0.01 mg/l

Air emission standards

- Mercury (Hydrogen gas holder) - 0.2 mg/Nm³
- Chlorine (Hypo tower) - 15 mg/Nm³
- Hydrochlorine vapor/mist - 35 mg/Nm³

These emission standards are notified under Environment (Protection) Act, 1986.

Hazardous waste generation as per HWM Rules, 2000

- Production of caustic soda/chlorine by - Asbestos containing discards. Means of mercury/diaphragm cell process and mercury-bearing sludge are to be properly collected, treated and disposed of as per the HWM Rules.
- Leachate quality of brine sludge (mercury cell process) should contain mercury less than or equal to 0.01 mg (proposed).

Energy Needs

In this background during the last three decades, the MBCP technology slowly gained ground and has now become an established technology. There exist several advantages for MBCP technology when compared to the MRCP technology. Some of the MBCP advantages are depicted below:

- Highly energy-efficient
- Reduces operating cost due to reduction in chemicals, manpower requirement, *etc*
- Higher product purity
- Reduced cell downtime
- Increase in capacity
- Avoidance of short-circuiting
- Avoidance of mercury

4. OPERATIONAL ASPECTS OF EIA

Prior environmental clearance process has been revised in the Notification issued on 14th September, 2006, and amended as on 1st December, 2009, fall into following four major stages *i.e.*, screening, scoping, public consultation and appraisal. Each stage has certain procedures to be followed. This section deals with all the procedural and technical guidance, for conducting objective-oriented EIA studies, their review and decision-making. Besides, the Notification also classifies projects into Category A, which requires prior environmental clearance from MoEF and Category B from SEIAA/UTEIAA.

Consistency with other requirements

- Clearance from other regulatory bodies is not a pre-requisite for obtaining the prior environmental clearance and all such clearances will be treated as parallel statutory requirements.
- Consent for Establishment (CFE) and Prior Environmental Clearance are two different legal requirements a project proponent should acquire. Therefore, these two activities can be initiated and proceeded with simultaneously.
- If a project falls within the purview of CRZ and EIA Notifications, then the project proponent is required to take separate clearances from the concerned Authorities.
- Rehabilitation and Resettlement (R&R) issues need not be dealt under the EIA Notification as other statutory bodies deal with these issues. However, socio-economic studies may be considered while taking environmental decisions.

4.1 Coverage of Chlor-alkali Industry under the Purview of Notification

Notification permits only membrane based cell technology which gives rise to the following three possibilities:

(a) Closure of MRCP and establishment of a new MBCP (Existing units converting to membrane cell technology) of same capacity:

In this case, if an MBCP is proposed on the same site where MRCP is in operation but total production capacity is same as granted earlier for the MTCP, the MBCP does not require an EIA clearance. However, in case of full capacity conversion, while granting the consents, the State Govt. Authorities may ensure that new membrane cell based unit should include mercury management plan (removal of deposited mercury from equipment, pipelines and other components of old MRCP to be used for the new MBCP, monitoring of soil, and groundwater, *etc*). If these are contaminated, a remedial action plan including capping and containment should be implemented.

(b) In case of partial capacity conversion (*i.e.*, partly membrane and partly mercury cell based technology):

In this case, if the new MBCP is proposed on the same site where MRCP is in operation but total production capacity is less than already granted capacity for the MRCP, the new MBCP does not require EIA clearance. However, in case of partial conversion, while

granting the consents the State Govt. Authorities may ensure that new membrane cell based unit should include details on mercury management plan (removal of deposited mercury from equipment, pipelines and other components of old MRCP to be used for the new MBCP, monitoring of soil, and groundwater, *etc*). If these are contaminated, a remedial action plan including capping and containment may be implemented. Besides, closure plan of the existing remaining MRCP with gradual reduction in mercury emissions should be targeted in accordance to the CREP programme of MoEF. This may be made applicable as long as Hg cell is in operation.

(c) If a new membrane cell plant is coming up in a new site; or total capacity of the production is in excess of existing Hg based plant, the EIA clearance is required as per the notified criteria.

All new chlor-alkali industries including expansion and modernization require prior environmental clearance. Based on pollution potential, these projects are classified into Category A and Category B *i.e.*,

- Category A: projects having ≥ 300 TPD production capacity or a unit located outside the notified industrial area / estate.
- Category B: (i) all projects irrespective of the size if it is located in a Notified Industrial area / Estate (ii) < 300 TPD and located outside a Notified Industrial Area / Estate.

Besides there are general as well as specific conditions, when it applies, a Category B project will be treated as Category A project. These conditions are discussed in subsequent sections.

The sequence of steps in the process of prior environmental clearance for Category A projects and the Category B projects are shown in Figure 4.1 and Figure 4.2 respectively. The timelines indicated against each stage are the maximum permissible timelines set in the Notification for the said task. In case the said task is not cleared/objected by the concerned Authority, within the specified time, the said task is deemed to be cleared, in accordance to the proposal submitted by the proponent. Each stage in the process of prior environmental clearance for the chlor-alkali industry is discussed in subsequent sections.

In case of Expansion or Modernization of the existing chlor-alkali industry:

- Capacity increase of existing mercury-based chlor-alkali industry is not allowed.
- Any developmental activity, which has an EIA clearance (existing membrane plant), when undergoes expansion or modernization (change in process or technology) with or without increase in production capacity beyond the list of products cleared in the issued clearance, is required to submit new application for EIA clearance.
- Any developmental activity/partial conversion of mercury cell to membrane cell (existing mercury plant), which has an EIA clearance when undergoes modernization by conversion from mercury to membrane technology, does not require EIA clearance, as long as the total capacity is less than or equal to existing capacity.
- Any developmental activity, which is listed in Schedule of the EIA Notification and due to expansion of its total capacity, if falls under the purview of either Category B or Category A, then such developmental activity requires clearance from respective Authorities.

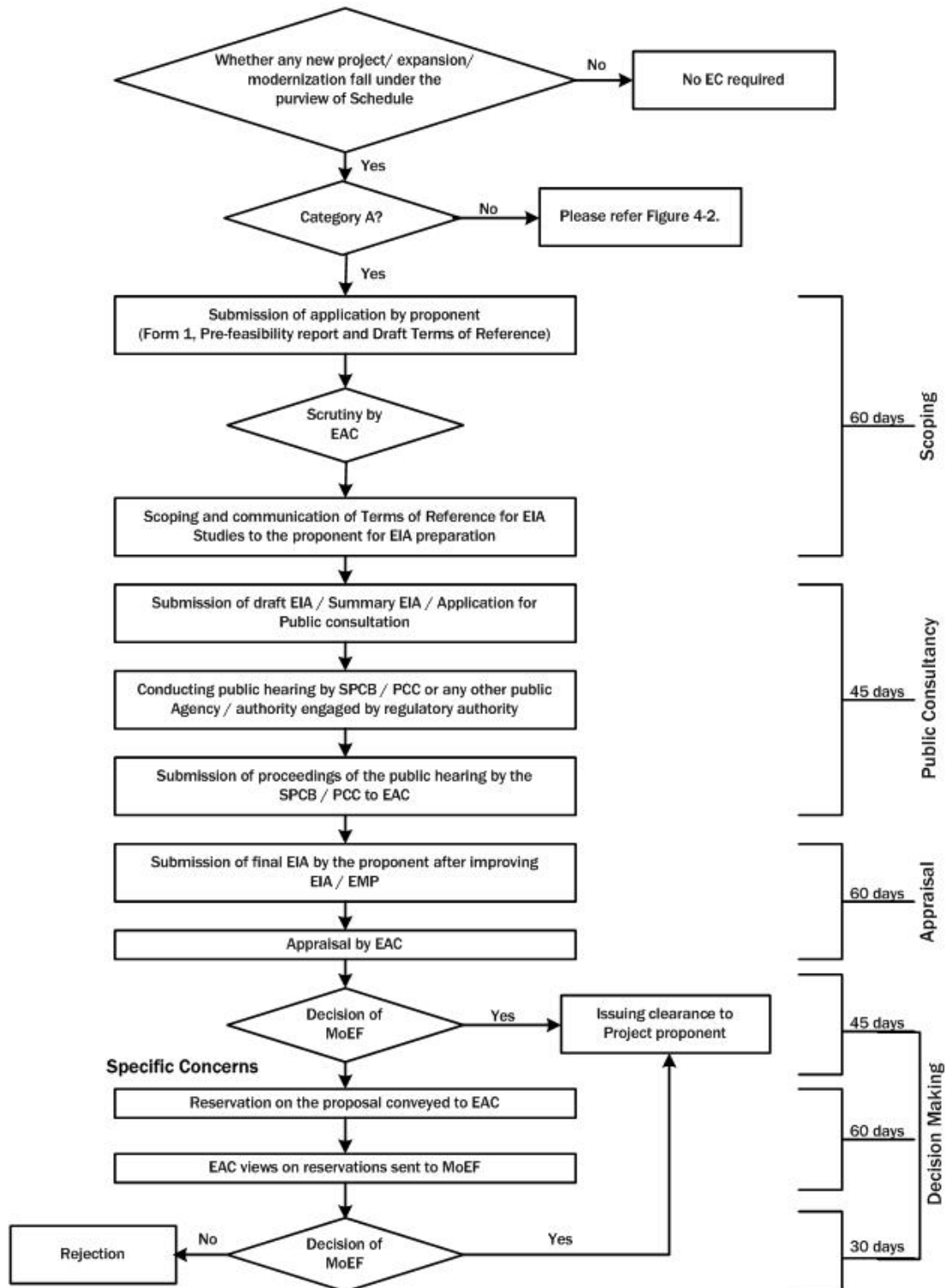

Figure 4-1: Prior Environmental Clearance Process for Activities falling Under Category A

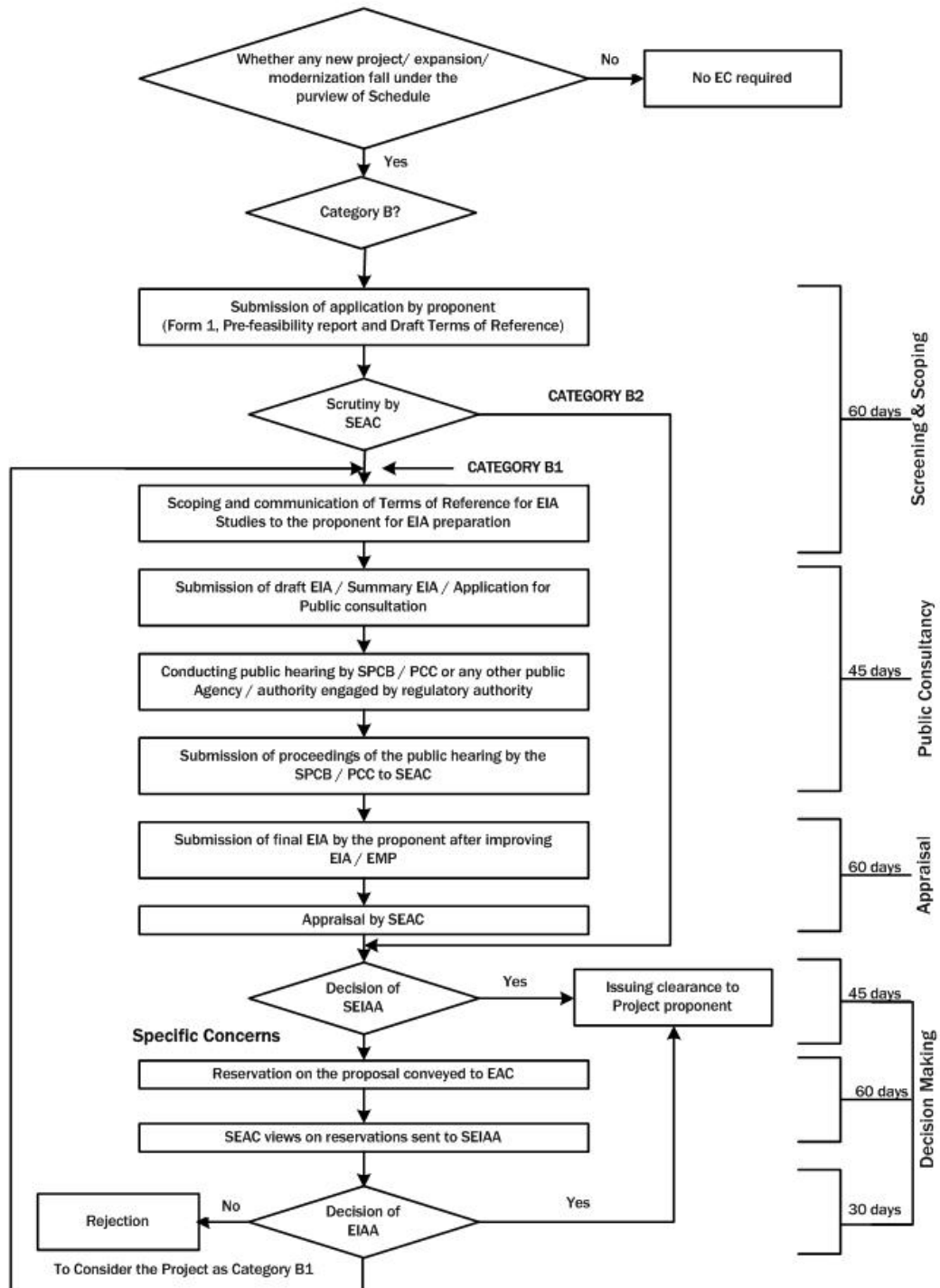

Figure 4-2: Prior Environmental Clearance Process for Activities Falling Under Category B

4.2 Screening

Screening of the project shall be performed at the initial stage of the project development so that proponents are aware of their obligations before deciding on the budget, project design and execution plan.

This stage is applicable only for Category ‘B’ developmental activity *i.e.*, if general conditions are applicable for a Category B project, then it will be treated as Category A project. Besides, screening also refers to the classification of Category B projects into either Category B1 or Category B2. Category B1 projects require to follow all stages applicable for a Category A project, but are processed at the SEIAA/UTEIAA. Category B2 projects, on the other hand, do not require either EIA or public consultation.

As per the Notification, classification of the Category B projects falls under the purview of the SEAC. This manual provides certain guidelines to the stakeholders for classification of Category B1 and Category B2.

4.2.1 Applicable conditions for Category B projects

Specific condition:

If any Industrial Estate/Complex/Export processing Zones/Special Economic Zones/Biotech Parks/Leather Complex with homogeneous type of industries such as Items 4(d), 4(f), 5(e), 5(f), or those Industrial Estates with pre-defined set of activities (not necessarily homogeneous, obtains prior environmental clearance, individual industries including proposed industrial housing within such estates / complexes will not be required to take prior environmental clearance, so long as the Terms and Conditions for the industrial estate/complex are complied with (Such estates/complexes must have a clearly identified management with the legal responsibility of ensuring adherence to the Terms and Conditions of prior environmental clearance, who may be held responsible for violation of the same throughout the life of the complex/estate).

General condition:

- Any project irrespective of the size if it is located in a Notified Industrial area / Estate or < 300 TPD and located outside a Notified Industrial Area / Estate (usually falling under Category B) will be treated as Category A, if located in whole or in part within 10 km from the boundary of:
 - Protected areas notified under the Wild Life (Protection) Act, 1972,
 - Critically polluted areas as notified by the CPCB from time to time
 - Eco-sensitive areas as notified under section 3 of the E(P) Act, 1986, such as Mahabaleshwar Panchgani, Matheran, Panchmarhi, Dahanu, Doon valley and
 - Inter-State boundaries and international boundaries - provided that the requirement regarding distance of 10 km of the inter-State boundaries can be reduced or completely done away with by an agreement between the respective States/UTs sharing the common boundary.
- If any of the conditions listed in above general condition applies, then a Category B project will be treated as Category A
- The SEIAA shall base its decision on the recommendations of a State/UT level EAC for the purpose of prior environmental clearance.

- In absence of a duly constituted SEIAA or SEAC, a Category B project shall be appraised at the Central level *i.e.*, at the MoEF
- The EAC at the State/UT level shall screen the projects or activities in Category B. SEAC shall meet at least once every month.
- If any Category B chlor-alkali project/activity, after proposed expansion of capacity/production or fuel change, falls under the purview of Category A in terms of production capacity, then clearance is required from the Central Government.

4.2.2 Criteria for classification of Category B1 and B2 projects

The classification of Category B projects or activities into B1 or B2 (except the project or activities listed in item 8(b) in the schedule to the EIA Notification, 2006) will be determined based on whether or not the project or activity requires further environmental studies for preparation of an EIA for its appraisal prior to the grant of prior environmental clearance. The projects requiring an EIA report shall be included in Category B1 and remaining projects will fall under Category B2 and will not require an EIA report and public consultation.

Any developmental activity in Chlor-alkali industry may not qualify for Category B2 due to the associated pollution problems and possible significant impacts..

4.2.3 Application for prior environmental clearance

- The project proponent, after identifying the site and carrying out a pre-feasibility study, is required to apply for the prior environmental clearance using Form 1 given in **Annexure III**. The proponent has to submit the filled in Form 1 along with the pre-feasibility report and draft terms of reference (ToR) for EIA studies to the concerned Authority *i.e.* MoEF, Government of India for Category A projects and to the SEIAA in case of Category B projects. Please refer subsequent sections for the information on how to fill the Form 1, contents of pre-feasibility report and draft ToR for Chlor-alkali sector.
- Prior environmental clearance is required before starting any construction work, or preparation of land on the identified site/project or activity by the project management, except for securing the land.
- If the application is made for a specific developmental activity, which has an inherent area development component as a part of its project proposal and the same project also attracts the construction and area development provisions under 8a and 8b of the Schedule, then the project will be seen as a developmental activity other than 8a and 8b of the Schedule.

4.2.4 Siting guidelines

These are the guidelines, stakeholders may consider while siting the developmental projects, to minimize the associated possible environmental impacts. In some situations, adhering to these guidelines is difficult and unwarranted. Therefore these guidelines may be kept in the background, as far as possible, while taking the decisions.

In case of conversion of plant from MRCP to MBCP technology, the proponent is required to submit the detailed plan on mercury inventory on the existing sites and mercury decontamination/remediation plan provide monitoring data for mercury in different receptors around the industrial sites periodically.

Areas preferably be avoided

While siting industries, care should be taken to minimize the adverse impact of the industries on immediate neighborhood as well as distant places. Some of the natural life sustaining systems and some specific landuses are sensitive to industrial impacts because of the nature and extent of fragility. With a view to protect such sites, the industries may maintain the following distances, as far as possible, from the specific areas listed:

- Ecologically and/or otherwise sensitive areas: Preferably 5 km; depending on the geo-climatic conditions the requisite distance may be decided appropriately by the agency.
- Coastal areas: Preferably ½ km away from high tide line (HTL).
- Flood plain of the riverine system: Preferably ½ km away from flood plain or modified flood plain affected by dam in the upstream or flood control systems.
- Transport/Communication System: Preferably ½ km. away from highway and railway line.
- Major settlements (3,00,000 population): Distance from major settlements is difficult to maintain because of urban sprawl. At the time of siting of the industry, if the notified limit of any major settlement is found to be within 50 km from the project boundary, the spatial direction of growth of the settlement for at least a decade must be assessed. Subsequently, the industry may be sited at least 25 km from the projected growth boundary of the settlement.
- Critically polluted areas are identified by MoEF from time-to-time. Current list of critically polluted areas is given in **Annexure IV**.

Note:

Ecological and/or otherwise sensitive areas include (i) Religious and Historic Places; (ii) Archaeological Monuments (e.g. identified zone around Taj Mahal); (iii) Scenic Areas; (iv) Hill Resorts; (v) Beach Resorts; (vi) Health Resorts; (vii) Coastal Areas rich in Corals, Mangroves, Breeding Grounds of Specific Species; (viii) Estuaries rich in Mangroves, Breeding grounds of Specific Species; (ix) Gulf Areas; (x) Biosphere Reserves; (xi) National Parks and Sanctuaries; (xii) Natural lakes, Swamps; (xiii) Seismic Zones; (xiv) Tribal Settlements; (xv) Areas of Scientific and Geological Interest; (xvi) Defence Installations, specially those of security importance and sensitive to pollution; (xvii) Border Areas (International) and (xviii) Air Ports.

Pre-requisite: State and Central Governments are required to identify such areas on a priority basis.

General siting factors

In any particular selected site, the following factors must also be recognized.

- No forest land shall be converted into non-forest activity for the sustenance of the industry (Ref: Forest Conversation Act, 1980).
- No prime agricultural land shall be converted into industrial site.
- Land acquired shall be sufficiently large to provide space for appropriate green cover including green belt, around the battery limit of the industry.
- Layout of the industry that may come up in the area must conform to the landscape of the area without affecting the scenic features of that place.

- Associated township of the industry may be created at a space having physiographic barrier between the industry and the township.

4.3 Scoping for EIA Studies

Scoping exercise is taken up soon after the project contours are defined. The primary purpose of scoping is to identify the concerns and issues which may affect the project decisions. Besides, scoping defines the requirements and boundaries of the EIA study.

Scoping refers to the process by which the EAC, in case of Category 'A' projects or activities, and SEAC in case of Category 'B1' projects, including applications for expansion and/or modernization of existing projects, determine ToR for EIA studies addressing all relevant environmental concerns for the preparation of an EIA Report for a particular project.

- Project proponent shall submit application to concerned Authority. The application (Form 1 as given in annexure III) shall be attached with pre-feasibility report and proposed ToR for EIA Studies. The proposed sequence to arrive at the draft ToR is discussed below:
 - Pre-feasibility report summarizes the project details and also the likely environmental concerns based on the secondary information, which will be availed for filling Form 1.
 - From pre-feasibility report and the Form 1, valued environmental components (VECs) may be identified for a given project (the receiving environment/social components, which are likely to get affected due to the project operations/activities).
 - Once the project details from the pre-feasibility report & Form 1; and VECs are identified, a matrix establishing the interactions which can lead to the effects/impacts could be developed (Qualitative analysis).
 - For each identified possible effect in the matrix, significance analysis could be conducted to identify the impacts, which needs to be studied further (quantitative analysis) in the subsequent EIA studies. All such points will find a mention in the draft ToR to be proposed by the project proponent along with the application form. The draft ToR shall include applicable baseline parameters (refer annexure VII) and impact prediction tools (refer annexure IX) proposed to be applied.
 - The information to be provided in pre-feasibility report, guidelines for filling Form 1 and guidelines for developing draft ToR is summarized in the subsequent sections.
 - Authority consults the respective EAC/SEAC to reply to the proponent. The EAC/SEAC concerned reviews the application form, pre-feasibility report and proposed draft ToR by the proponent and make necessary additions/deletions to make it a comprehensive ToR that suits the statutory requirements for conducting the EIA studies.
- The concerned EAC/SEAC may constitute a sub-committee for a site visit, if considered necessary. The sub-committee will act up on receiving a written approval from chairperson of the concerned EAC/SEAC. Project proponent shall facilitate such site visits of the sub-committees.
- EAC/SEAC shall provide an opportunity to the project proponent for presentation and discussions on the proposed project and related issues as well as the proposed ToR for

EIA studies. If the State Government desires to present its views on any specific project in the scoping stage, it can depute an officer for the same at the scoping stage to EAC, as an invitee but not as a member of EAC. However, non-appearance of the project proponent before EAC/SEAC at any stage will not be a ground for rejection of the application for the prior environmental clearance.

- If a new or expansion project is proposed in a problem area as identified by the CPCB, then the Ministry may invite a representative of SEIAA to the EAC to present their views, if any, at the stage of scoping.
- The final set of ToR for EIA studies shall be conveyed to the proponent by the EAC/SEAC within sixty days of the receipt of Form 1 and pre-feasibility report. If the finalized ToR for EIA studies is not conveyed to the proponent within sixty days of the receipt of Form 1, the ToR for EIA studies suggested by the proponent shall be deemed as the final and will be approved for the EIA studies.
- Final ToR for EIA studies shall be displayed on the website of the MoEF/SEIAA.
- Applications for prior environmental clearance may be rejected by the concerned Authority based on the recommendations by the concerned EAC/SEAC at the scoping stage itself. In case of such rejection, the decision together with reasons for the same shall be communicated to the proponent in writing within sixty days of the receipt of the application.
- The final EIA report and other relevant documents submitted by the applicant shall be scrutinized by the concerned Authority strictly with reference to the approved ToR for EIA studies.

4.3.1 Pre-feasibility report

The pre-feasibility report should include, but not limited to highlight the proposed project information, keeping in view the environmental sensitivities of the selected site, raw material (NaCl, KCl, *etc.*), technology options (MBCP, DCP, *etc.*) and its availability. Information required in pre-feasibility report varies from case-to-case even in same sector depending upon the local environmental setting within which the plant is located/proposed. However, the information which may be furnished in the pre-feasibility report may include as under:

I. Executive summary

II. Project details: Description of the project including in particular;

- a description of the main characteristics of the production processes, for instance, nature and quantity of materials used
- an estimate, by type and quantity, of expected residues and emissions (water, air and soil pollution, noise, heat, radiation, *etc.*) resulting from the operation of the proposed project
- a description of the physical characteristics of the whole project and the landuse requirements during the construction and operational phases

III. Selection of site based on least possible impacts

- An outline of the main alternatives studied by the developer and an indication of the main reasons for this choice, taking into account the environmental effects.

IV. Anticipated impacts based on project operations on receiving environment

- A description of the aspects of the environment likely to be significantly affected by the proposed project, including, in particular, population, fauna, flora, soil, water, air, climatic factors, material assets, including the architectural and archaeological heritage, landscape and the inter-relationship between the above factors.
- A description of the likely significant effects of the proposed project on the environment resulting from:
 - existence of the project,
 - use of natural resources,
 - emission of pollutants, the creation of nuisances and the elimination of waste
 - project proponent's description of the forecast methods used to assess the effects on the environment

V. Proposed broad mitigation measures which could effectively be internalized as project components to have environmental and social acceptance of the proposed site

- A description of key measures envisaged to prevent, reduce and where possible offset any significant adverse effects on the environment

VI. An indication of any difficulties (technical deficiencies or lack of know-how) encountered by the developer in compiling the required information

Details of the above listed points which may be covered in pre-feasibility report are listed in **Annexure V**.

4.3.2 Guidance for providing information in Form 1

The information given in specifically designed pre-feasibility report for this developmental activity may also be availed for filling Form 1.

Form 1 is designed to help users identify the likely significant environmental effects of proposed projects right at the scoping stage. There are two stages for providing information under two columns:

- First - identifying the relevant project activities from the list given in Column 2 of Form 1. Start with the checklist of questions set out below and complete Column 3 by answering:
 - Yes - if the activity is likely to occur during implementation of the project
 - No - if it is not expected to occur
 - May be - if it is uncertain at this stage whether it will occur or not
- Second - Each activity for which the answer in Column 3 is "Yes" the next step is to refer to the fourth column which quantifies the volume of activity which could be judged as significant impact on the local environmental characteristics, and identify the areas that could be affected by that activity during construction /operation / decommissioning of the project. Form 1 requires information within 15 km around the project, whereas actual study area for EIA studies will be as prescribed by

respective EAC/SEAC. Project proponent will need information about the surrounding VECs in order to complete this Form 1.

4.3.3 Identification of appropriate valued environmental components

VECs are components of natural resources and human world that are considered valuable and are likely to be affected by the project activities. Value may be attributed for economic, social, environmental, aesthetic or ethical reasons. VECs represent the investigative focal point for further EIA process. The indirect and/or cumulative effects can be concerned with indirect, additive or even synergistic effects due to other projects or activities or even induced developments on the same environmental components as would be considered direct effects. But such impacts tend to involve larger scale VECs such as within entire region, river basins or watersheds; and, broad social and economic VECs such as quality of life and the provincial economy. Once VECs are identified then appropriate indicators are selected for impact assessments on the respective VECs.

4.3.4 Methods for identification of impacts

There are various factors which will influence the approach adopted for the assessment of direct, indirect, cumulative impacts, *etc.* for a particular project. The method should be practical and suitable for the project given the data, time and financial resources available. However, the method adopted should be able to provide a meaningful conclusion from which it would be possible to develop, where necessary, mitigation measures and monitoring. Key points to consider when choosing the method(s) include:

- Nature of the impact(s)
- Availability and quality of data
- Availability of resources (time, finance and staff)

The method chosen should not be complex, but should aim at presenting the results in a way that can be easily understood by the developer, decision maker and the public. A comparative analysis of major impact identification methods is given in Table 4-1:

Table 4-1: Advantages and Disadvantages of Impact Identification Methods

	Description	Advantages	Disadvantages
Checklists	<ul style="list-style-type: none"> ▪ Annotate the environmental features that need to be addressed when identifying the impacts of activities in the project 	<ul style="list-style-type: none"> ▪ Simple to understand and use ▪ Good for site selection and priority setting ▪ Simple ranking and weighting 	<ul style="list-style-type: none"> ▪ Do not distinguish between direct and indirect impacts ▪ Do not link action and impact ▪ The process of incorporating values can be controversial
Matrices	<ul style="list-style-type: none"> ▪ Identify the interaction between project activities (along one axis) and environmental characteristics (along other axis) using grid like table ▪ Entries are made in the cells which highlights impact 	<ul style="list-style-type: none"> ▪ Link action to impact ▪ Good method for displaying EIA results 	<ul style="list-style-type: none"> ▪ Difficult to distinguish direct and indirect impacts ▪ Significant potential for double-counting of impacts

	Description	Advantages	Disadvantages
	severity in the form of symbols or numbers or descriptive comments		
Networks	<ul style="list-style-type: none"> ▪ Illustrate cause effect relationship of project activities and environmental characteristics ▪ Useful in identifying secondary impacts ▪ Useful for establishing impact hypothesis and other structured science based approaches to EIA 	<ul style="list-style-type: none"> ▪ Link action to impact ▪ Useful in simplified form for checking for second order impacts ▪ Handles direct and indirect impacts 	<ul style="list-style-type: none"> ▪ Can become very complex if used beyond simplified version
Overlays	<ul style="list-style-type: none"> ▪ Map the impacts spatially and display them pictorially ▪ Useful for comparing site and planning alternatives for routing linear developments ▪ Can address cumulative effects ▪ Information intensive 	<ul style="list-style-type: none"> ▪ Easy to understand ▪ Good to display method ▪ Good siting tool 	<ul style="list-style-type: none"> ▪ Address only direct impacts ▪ Do not address impact duration or probability
GIS	<ul style="list-style-type: none"> ▪ Maps the impacts spatially and display them pictorially ▪ Useful for comparing site and planning alternatives for routing linear developments ▪ Can address cumulative effects ▪ Information intensive 	<ul style="list-style-type: none"> ▪ Easy to understand ▪ Good to display method ▪ Good siting tool ▪ Excellent for impact identification and analysis 	<ul style="list-style-type: none"> ▪ Do not address impact duration or probability ▪ Heavy reliance on knowledge and data ▪ Often complex and expensive
Expert System	<ul style="list-style-type: none"> ▪ Assist diagnosis, problem solving and decision making ▪ Needs inputs from user by answering systematically developed questions to identify impacts and determine their mitigability and significance ▪ Information intensive, high investment methods of analysis 	<ul style="list-style-type: none"> ▪ Excellent for impact identification and analysis ▪ Good for experimenting 	<ul style="list-style-type: none"> ▪ Heavy reliance on knowledge and data ▪ Often complex and expensive

The project team made an attempt to construct an impact matrix considering major project activities (generic operations) and stage-specific likely impacts which is given in Table 4-2.

While the impact matrix is project-specific, Table 4-2 may facilitate the stakeholders in identifying a set of components and phase-specific project activities for determination of likely impacts. However, the location-specific concerns may vary from case-to-case; therefore, the components even without likely impacts are also retained in the matrix for the location-specific reference.

Table 4-2: Matrix of Impacts

1	2	3	PHASE I					PHASE II							PHASE III					
			Pre Construction					Construction/ Establishment							Operation and Maintenance					
			4	5	6	7	8	9	10	11	12	13	14	15	16	17	18	19	20	
ENVIRONMENT	Component	Project Activities Parameter/ factor	Detailed Topographic Survey	Land Acquisition	Site Clearing	Burning of wastes, refuse and cleared vegetation	Site Preparation / Change in Topography	Civil works such as earth moving and building of structures including temporary structures	Heavy Equipment operations	Disposal of construction wastes	Generation of sewerage	Influx of construction workers	Deforestation	Transportation of material	Raw material transportation, storage and handling	Brine preparation – resaturation, dechlorination, etc.	Electrolysis process	Product storage and handling – Chlorine and associated products	Waste management	
Physical	Soil	Erosion Risks											*							
		Contamination						*		*					*	*			*	*
		Soil Quality						*							*	*				*
	Resources	Fuels/ Electricity													*			*		
		Raw materials						*								*	*			
		Land especially undeveloped or agricultural land								*										
	Water	Interpretation or Alteration of River Beds					*													
		Alteration of Hydraulic Regime											*							
		Alteration of surface run-off and interflow					*	*												
		Alteration of aquifers					*	*												
		Water quality					*	*			*				*	*			*	*
	Air	Air quality	Temperature																	
			Air quality			*	*	*	*	*	*	*	*	*	*	*	*	*	*	*

Operational Aspects of an EIA

			PHASE I					PHASE II					PHASE III							
			Pre Construction					Construction/ Establishment					Operation and Maintenance							
1	2	3	4	5	6	7	8	9	10	11	12	13	14	15	16	17	18	19	20	
		Noise						*	*					*						
		Climate				*							*							
Biological	Terrestrial Flora	Effect on grass & flowers			*		*			*			*							
		Effect on trees & shrubs			*		*						*							
		Effect on farmland			*		*				*									
		Endangered species			*		*							*						
		Aquatic Biota	Habitat removal			*		*										*		
	Contamination of habitats				*		*									*	*		*	*
	Reduction of aquatic biota				*		*										*		*	*
	Terrestrial Fauna	Fragmentation of terrestrial habitats			*		*							*						
		Disturbance of habitats by noise or vibration			*		*										*			
		Reduction of Biodiversity			*		*							*		*	*		*	*
Social	Economy	Creation of new economic activities	*									*				*	*	*	*	
		Commercial value of properties											*			*	*	*	*	*
		Conflict due to negotiation and/ compensation payments																		
		Generation of temporary and permanent jobs											*			*	*	*	*	*
		Effect on crops			*				*			*					*			
		Reduction of farmland productivity		*																
		Income for the state and private sector																	*	*
		Savings for consumers & private consumers																*	*	

Operational Aspects of an EIA

			PHASE I					PHASE II					PHASE III						
			Pre Construction					Construction/ Establishment					Operation and Maintenance						
1	2	3	4	5	6	7	8	9	10	11	12	13	14	15	16	17	18	19	20
		Savings in foreign currency for the state																*	
	Education	Training in new technologies	*												*	*	*	*	*
		Training in new skills to workers	*												*	*	*	*	*
	Public Order	Political Conflicts		*															
		Unrest, Demonstrations & Social conflicts			*														
	Infrastructure and Services	Conflicts with projects of urban, commercial or Industrial development	*					*									*	*	*
	Security and Safety	Increase in Crime								*									
		Accidents caused by								*					*	*	*	*	*
	Health					*													
	Cultural	Land use			*		*								*	*		*	*
		Recreation														*		*	*
		Aesthetics and human interest									*			*		*		*	*
		Cultural status																	

Note:

1. Above table represents a model for likely impacts, which will have to be arrived at on a case-to-case basis considering VECs and significance analysis (Ref Section 2.9).

2. Project activities are shown as indicative. However, in Form 1 (application for EIA Clearance), for any question for which answer is 'Yes', then the corresponding activity shall reflect in project activities. Similarly 'parameters'/'factors' will also be changed within a component in order to reflect the target species of prime concern in the receiving local environment.

4.3.5 Testing the Significance of Impacts

The following set of conditions may be used as the checklist for testing the significance of the impacts and also to provide information in Column IV of Form 1.

- Will there be a large change in environmental conditions?
- Will new features be out-of-scale with the existing environment?
- Will the effect be unusual in the area or particularly complex?
- Will the effect extend over a large area?
- Will there be any potential for trans-frontier impact?
- Will many people be affected?
- Will many receptors of other types (fauna and flora, businesses, facilities) be affected?
- Will valuable or scarce features or resources be affected?
- Is there a risk that environmental standards will be breached?
- Is there a risk that protected sites, areas, and features will be affected?
- Is there a high probability of the effect occurring?
- Will the effect continue for a long time?
- Will the effect be permanent rather than temporary?
- Will the impact be continuous rather than intermittent?
- If it is intermittent will it be frequent rather than rare?
- Will the impact be irreversible?
- Will it be difficult to avoid, or reduce or repair or compensate for the effect?

For each “Yes” answer in column 3, the nature of effects and reasons for it should be recorded in the column 4. The questions are designed so that a “Yes” answer in column 3, will generally point towards the need for analyzing for the significance and requirement for conducting impact assessment for the effect.

4.3.6 Terms of reference for EIA studies

ToR for EIA studies in respect of chlor-alkali industry may include, but not limited to the following:

1. Executive summary of the project – giving a *prima facie* idea of the objectives of the proposal, use of resources, justification, *etc.* In addition, it should provide a compilation of EIA report, including EMP and the post-project monitoring plan in brief.

Project description

2. Details on demand of the product – chlorine and its associated products.
3. Justification for selecting the proposed unit size.
4. Land requirement for the project including its break up for various purposes, its availability and optimization.
5. Details of proposed layout clearly demarcating various facilities of the plant.
6. Complete process flow diagram describing each unit, its processes and operations, along with material and energy inputs and outputs (material and energy balance).
7. Details on raw materials used in the production of chlorine (sodium chloride, potassium chloride, *etc.*), its storage and handling.

8. Details on process (diaphragm/membrane).
9. Details of proposed source-specific pollution control schemes (salt washing, filtration, cell ventilation gas, chlorine handling and safety, *etc.*) and equipments to meet the national standards.
10. Details on product storage and handling – chlorine, caustic soda, *etc.*
11. Details on tail gas treatment.
12. Details on chlorine liquefaction.
13. Details on requirement of energy and water along with its source and authorization from the concerned department.
14. Details on water balance including quantity of effluent generated, recycled and reused. Efforts to minimize effluent discharge and to maintain quality of receiving water body.
15. Details of effluent treatment plant, inlet and treated water quality with specific efficiency of each treatment unit in reduction in respect of all concerned/regulated environmental parameters.
16. Details of the proposed methods of water conservation and recharging.
17. Management plan for solid/hazardous waste generation, composition, storage, utilization and disposal.
18. Details regarding infrastructure facilities such as fuel storage, sanitation, restroom, *etc.*, to the workers during construction and operation phase.
19. In case of modernisation of existing mercury based chlor-alkali plants with membrane cell process (MBCP) industries or new units in the existing industry premises, remediation measures adopted to restore the environmental quality of the groundwater, soil, crop, air, *etc.*, are affected due to salinity and a detailed compliance to the prior environmental clearance/consent conditions.
20. Any litigation pending against the project and /or any direction /order passed by any Court of Law related to the environmental pollution and impacts in the last two years,, if so, details thereof.

Description of the environment

21. The study area shall be up to a distance of 5 km from the boundary of the proposed project site.
22. Location of the project site, township and nearest villages with distances from the site to be demarcated on a toposheet (1: 50000 scale).
23. Land use based on satellite imagery including location of national parks/wildlife sanctuary, villages, industries, *etc.*
24. Demography details of all the villages.
25. Topography details of the project area.
26. The baseline data to be collected from the study area w.r.t. different components of environment *viz.* air, noise, water, land, and biology and socio-economic (please refer Section 4.4.2 for guidance for assessment of baseline components and attributes). Actual monitoring of baseline environmental components shall be strictly according to the parameters prescribed in the ToR and shall commence after finalization of ToR by the competent Authority.

27. Geological features and geo-hydrological status of the study area.
28. Details of groundwater and surface water quality of nearby water sources and other surface drains.
 - Water quality parameters for existing mercury based plant: Combined MRCP & MBCP include Residual chlorine*, TDS*, alkalinity*, pH* & Mercury* (in water & sediment), *etc.* (* - as applicable)
 - Water quality parameters for membrane cell process based plant include Residual chlorine*, TDS*, alkalinity*, pH*, *etc.* (* - as applicable)
29. Details on existing ambient air quality and expected emissions for
 - Existing mercury based plant (combined MRCP and MBCP) include Chlorine*, Hg*, acid mist* in stacks, work zone, factory boundary, & ambient air, *etc.* (* - as applicable)
 - Membrane cell process (MBCP) include Chlorine*, acid mist* in stacks, work zone, factory boundary, & ambient air, *etc.* (* - as applicable)
30. The air quality contours may be plotted on a location map showing the location of project site, habitation nearby, sensitive receptors, if any, and wind roses.
31. Details on noise level monitoring from at all the four locations surrounding the project area and also at sensitive/commercial receptor.
32. Site-specific micro-meteorological data including inversion height and mixing height.
33. One season site-specific data excluding monsoon season.
34. Ecological status (terrestrial and aquatic) of the study area such as habitat type and quality, species, diversity, rarity, fragmentation, ecological linkage, age, abundance, *etc.*
35. If any incompatible land use attributes fall within the study area, proponent shall describe the sensitivity (distance, area and significance) and propose the additional points based on significance for review and acceptance by the EAC/SEAC. Incompatible land use attributes include:
 - Public water supply areas from rivers/surface water bodies, from ground water
 - Scenic areas/tourism areas/hill resorts
 - Religious places, pilgrim centers that attract over 10 lakh pilgrims a year
 - Protected tribal settlements (notified tribal areas where industrial activity is not permitted)
 - Monuments of national significance, World Heritage Sites
 - Cyclone, Tsunami prone areas (based on last 25 years);
 - Airport areas
 - Any other feature as specified by the State or local government and other features as locally applicable, including prime agricultural lands, pastures, migratory corridors, *etc.*
36. If ecologically sensitive attributes fall within the study area, proponent shall describe the sensitivity (distance, area and significance) and propose the additional points based on significance for review and acceptance by the EAC/ SEAC. Ecological sensitive attributes include:
 - National parks
 - Wild life sanctuaries
 - Tiger reserve/elephant reserve/turtle nesting ground

- Mangrove area
 - Reserved and protected forests
 - Any other closed/protected area under the Wild Life (Protection) Act, 1972
 - Any other eco-sensitive areas
37. If the location falls in Valley, specific issues connected to the natural resources management shall be studied and presented.
38. If the location falls in CRZ area: A CRZ map duly authenticated by one of the authorized agencies demarcating LTL, HTL, CRZ area, location of the project and associate facilities w.r.t. CRZ, coastal features such as mangroves, if any.
- Provide the CRZ map in 1:10000 scale in general cases and in 1:5000 scale for specific observations.
 - Proposed site for disposal of dredged material and environmental quality at the point of disposal/impact areas.
 - Fisheries study should be done w.r.t. Benthos and Marine organic material and coastal fisheries.

Anticipated environmental impacts and mitigation measures

39. Anticipated generic environmental impacts due to this project are indicated in Table 4-2, which may be evaluated for significance and based on corresponding likely impacts VECs may be identified. Baseline studies may be conducted for all these VECs and likely impacts will have to be assessed for their magnitude in order to identify mitigation measures (please refer Chapter 4 of the manual for guidance).
40. Tools as given in Section 4.4.3 may be referred for the appropriate assessment of environmental impacts.
41. While identifying the likely impacts, also include the following for analysis of significance and required mitigation measures:
- impacts due to transportation of raw materials and end products on the surrounding environment
 - impacts due to emissions from cell process on air
 - impacts due to wastewater from cell process on surface water, soil and groundwater
 - impacts due to generation of solid/hazardous waste during brine preparation and process
 - impacts due to odour pollution
 - impacts due to noise
 - impacts due to fugitive emissions
 - impact on health of workers due to proposed project activities
42. In case of likely impact from the proposed project on the surrounding reserve forests, if any, plan for the conservation of wild fauna in consultation with the State Forest Department.
43. Proposed odour control measures.
44. For identifying the mitigation measures, please refer Chapter III for source control and treatment. Besides typical mitigation measures which may also be considered are discussed in Table 4-5.

45. Action plan for green belt development including the details of species, width of plantation, planning schedule, *etc.* in accordance to CPCB published guidelines.

Analysis of alternative resources and technologies

46. Comparison of alternate sites considered and the reasons for selecting the proposed site. Conformity of the site with the prescribed guidelines in terms of CRZ, river, highways, railways, *etc.*
47. Details on improved technologies.
48. Details on proposed recovery options.

Environmental monitoring program

49. Monitoring programme for environmental parameters at source control.
50. Monitoring pollutants at receiving environment for the appropriate notified parameters – air quality, groundwater, surface water, *etc.* during operational phase of the project.
51. Stack and fugitive emissions may be monitored for PM10, PM2.5, SO₂, NO_x, HC, CO, acid mist, HCl, Cl₂, and Hg (Hg in case of existing Hg based plant).
52. Specific programme to monitor safety and health protection of workers.
53. Specific monitoring programme for Hg in groundwater, if the Hg based plant site is proposed to be availed by proponent.
54. Appropriate monitoring network has to be designed and proposed to assess the possible residual impacts on VECs.
55. Details of in-house monitoring capabilities and the recognized agencies if proposed for conducting monitoring.

Additional studies

56. Details on risk assessment and damage control during different phases of the project and proposed safeguard measures.
57. Details on socio-economic development activities such as commercial property values, generation of jobs, education, social conflicts, cultural status, accidents, *etc.*
58. Proposed plan to handle the socio-economic influence on the local community. The plan should include quantitative dimension as far as possible.
59. Details on compensation package for the people affected by the project, considering the socio-economic status of the area, homestead ousters, land ousters, and landless laborers.
60. Points identified in the public hearing and commitment of the project proponent to the same. Detailed action plan addressing the issues raised, and the details of necessary allocation of funds.
61. Details on plan for corporate social responsibility including the villages, population spread, SC/ST/backward communities, upgradation of existing schools, establishing new schools with facilities (such as laboratories, toilets, *etc.*), link roads, community halls, primary health facilities, health camps, *etc.*

Environmental management plan

- 62. Administrative and technical organizational structure to ensure proposed post-project monitoring programme for approved mitigation measures.
- 63. EMP devised to mitigate the adverse impacts of the project should be provided along with item-wise cost of its implementation (Capital and recurring costs).
- 64. Allocation of resources and responsibilities for plan implementation.
- 65. Details of the emergency preparedness plan for chlorine/Hydrogen storage, handling and transportation and on-site and off-site disaster management plan.

Note:

Above points shall be adequately addressed in the EIA report at corresponding chapters, in addition to the contents given in the reporting structure (Table: 4-6).

4.4 Environmental Impact Assessment

The generic approach for accomplishing EIA studies is shown in Figure 4.3. Each stage is discussed, in detail in subsequent sections.

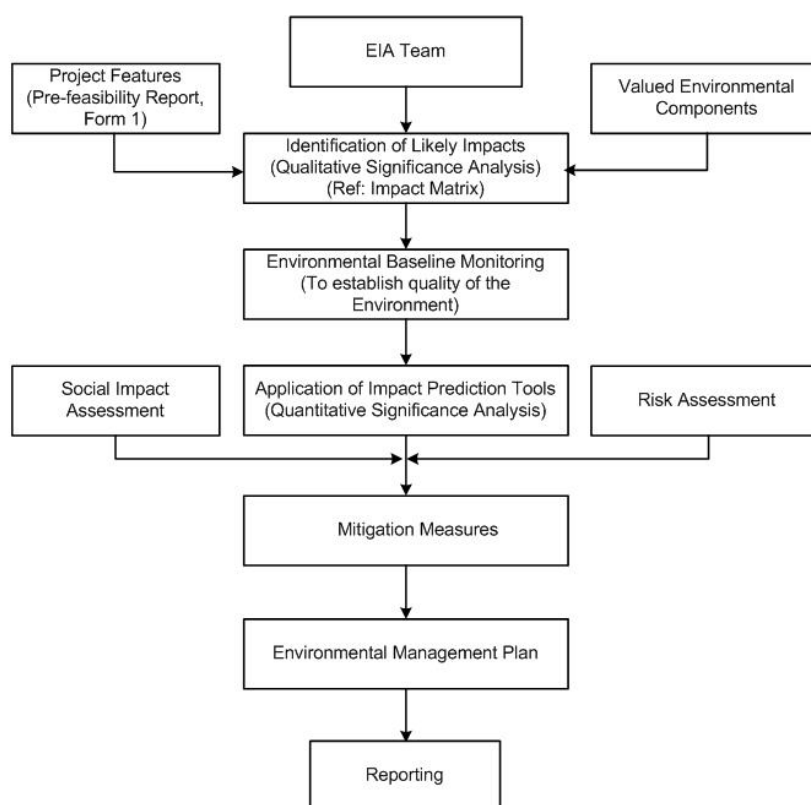

Figure 4-3: Approach for EIA Study

4.4.1 EIA team

The success of a multi-functional activity like an EIA primarily depends on constitution of a right team at the right time (preferable at the initial stages of an EIA) in order to assess the significant impacts (direct, indirect as well as cumulative impacts).

The professional Team identified for a specific EIA study should consist of qualified and experienced professionals from various disciplines in order to address the critical aspects identified for the specific project. Based on the nature and the environmental setting, following professionals may be identified for EIA studies:

- Environmental management specialist/regulatory expert
- Occupational safety and health expert
- Air and noise quality expert
- Water quality expert
- Chemical engineer
- Geology/geo-hydrology expert
- Ecologist
- Social scientist, *etc*

4.4.2 Baseline quality of the environment

EIA Notification 2006 specifies that an EIA Report should contain a description of the existing environment that would be or might be affected directly or indirectly by the proposed project. Environmental Baseline Monitoring (EBM) is a very important stage of EIA. On one hand EBM plays a very vital role in EIA and on the other hand it provides feedback about the actual environmental impacts of a project. EBM, during the operational phase, helps in judging the success of mitigation measures in protecting the environment. Mitigation measures, in turn are used to ensure compliance with environmental standards, and to facilitate the needed project design or operational changes.

Description of the existing environment should include natural, cultural, socio-economic systems and their interrelationships. The intention is not to describe all baseline conditions, but to focus the collection and description of baseline data on those VECs that are important and are likely to be affected by the proposed industrial activity.

4.4.2.1 Objectives of EBM in the EIA context

The term 'baseline' refers to conditions existing before development. EBM studies are carried out to:

- identify environmental conditions which might influence project design decisions (*e.g.*, site layout, structural or operational characteristics);
- identify sensitive issues or areas requiring mitigation or compensation;
- provide input data to analytical models used for predicting effects;
- provide baseline data against which the results of future monitoring programs can be compared.

At this stage of EIA process, EBM is primarily discussed in the context of first purpose wherein the feedback from EBM programs may be used to:

- determine available assimilative capacity of different environmental components within the designated impact zone and whether more or less stringent mitigation measures are needed; and
- improve predictive capability of EIAs.

There are many institutional, scientific, quality control, and fiscal issues that must be addressed in implementation of an environmental monitoring program. Careful consideration of these issues in the design and planning stages will help avoid many of the pitfalls associated with environmental monitoring programs. Such major issues are as under:

4.4.2.2 Environmental monitoring network design

Monitoring refers to the collection of data through a series of repetitive measurements of environmental parameters (or, more generally, to a process of systematic observation). Design of the environmental quality monitoring programme depends up on the monitoring objectives specified for the selected area of interest. Types of monitoring and network design considerations are discussed in **Annexure VI**.

4.4.2.3 Baseline data generation

List of important physical environmental components and indicators of EBM are given in Table 4-3.

Table 4-3: List of Important Physical Environment Components and Indicators of EBM

Environmental Component	Environmental Indicators
Climatic variables	<ul style="list-style-type: none"> ▪ Rainfall patterns – mean, mode, seasonality ▪ Temperature patterns ▪ Extreme events ▪ Climate change projections ▪ Prevailing wind - direction, speed, anomalies ▪ Relative humidity ▪ Stability conditions and mixing height <i>etc.</i>
Topography	<ul style="list-style-type: none"> ▪ Slope form ▪ Landform and terrain analysis ▪ Specific landform types <i>etc.</i>
Drainage	<ul style="list-style-type: none"> ▪ Surface hydrology ▪ Natural drainage pattern and network ▪ Rainfall runoff relationships ▪ Hydrogeology ▪ Groundwater characteristics – springs, <i>etc.</i>
Soil	<ul style="list-style-type: none"> ▪ Type and characteristics ▪ Porosity and permeability ▪ Sub-soil permeability ▪ Run-off rate ▪ Infiltration capacity ▪ Effective depth (inches/centimeters) ▪ Inherent fertility ▪ Suitability for method of sewage disposal <i>etc.</i>
Geology	<ul style="list-style-type: none"> ▪ Underlying rock type, texture ▪ Surgical material ▪ Geologic structures (faults, shear zones, <i>etc.</i>) ▪ Geologic resources (minerals, <i>etc.</i>) <i>etc.</i>
Water	<ul style="list-style-type: none"> ▪ Raw water availability ▪ Water quality

Environmental Component	Environmental Indicators
	<ul style="list-style-type: none"> ▪ Surface water (rivers, lakes, ponds, gullies) – quality, water depths, flooding areas, <i>etc.</i> ▪ Ground water – water table, local aquifer storage capacity, specific yield, specific retention, water level depths and fluctuations, <i>etc.</i> ▪ Coastal ▪ Floodplains ▪ Wastewater discharges ▪ Thermal discharges ▪ Waste discharges <i>etc.</i>
Air	<ul style="list-style-type: none"> ▪ Ambient ▪ Respirable ▪ Airshed importance ▪ Odour levels <i>etc.</i>
Noise	<ul style="list-style-type: none"> ▪ Identifying sources of noise ▪ Noise due to traffic/transportation of vehicles ▪ Noise due to heavy equipment operations ▪ Duration and variations in noise over time <i>etc.</i>
Coastal dynamics and morphology	<ul style="list-style-type: none"> ▪ Wave patterns ▪ Currents ▪ Shoreline morphology – near shore, foreshore ▪ Sediment – characteristics and transport <i>etc.</i>
Biological	<ul style="list-style-type: none"> ▪ Species composition of flora and fauna ▪ Flora – type, density, exploitation, <i>etc.</i> ▪ Fauna – distribution, abundance, rarity, migratory, species diversity, habitat requirements, habitat resilience, economic significance, commercial value, <i>etc.</i> ▪ Fisheries – migratory species, species with commercial/recreational value <i>etc.</i>
Land use	<ul style="list-style-type: none"> ▪ Landuse pattern, <i>etc.</i> ▪ Change in landuse <i>etc.</i>

Guidance for assessment of baseline components and attributes describing sampling network, sampling frequency, method of measurement is given in **Annexure VII**.

Infrastructure requirements for EBM

In addition to devising a monitoring network design and monitoring plans/program, it is also necessary to ensure adequate resources in terms of staffing, skills, equipment, training, budget, *etc.*, for its implementation. Besides assigning institutional responsibility, reporting requirements, QA/QC plans and its enforcement capability are essential. A monitoring program that does not have an infrastructural support and QA/QC component will have little chance of success.

Defining data statistics/analyses requirements

The data analyses to be conducted are dictated by the objectives of the environmental monitoring program. Statistical methods used to analyze data should be described in detail prior to data collection. This is important because repetitive observations are recorded in time and space. Besides, the statistical methods could also be chosen so that uncertainty or error estimates in the data can be quantified. For *e.g.*, statistical methods useful in an environmental monitoring program include: 1) frequency distribution

analysis; 2) analysis of variance; 3) analysis of covariance; 4) cluster analysis; 5) multiple regression analysis; 6) time series analysis; 7) the application of statistical models.

Use of secondary data

The EBM program for EIA can at best address temporal and/or spatial variations limited to a limited extent because of cost implications and time limitations. Therefore analysis of all available information or data is essential to establish the regional profiles. So all the relevant secondary data available for different environmental components should be collated and analyzed.

To facilitate stakeholders, IL&FS Ecosmart Ltd., has made an attempt to compile the list of information required for EIA studies and the sources of secondary data, which are given in **Annexure VIIIA** and **Annexure VIIIB**.

4.4.3 Impact prediction tools

The scientific and technical credibility of an EIA relies on the ability of EIA practitioners to estimate the nature, extent, and magnitude of change in environmental components that may result from project activities. Information about predicted changes is needed for assigning impact significance, prescribing mitigation measures, and designing & developing EMPs and monitoring programs. The more accurate the predictions, the more confident the EIA practitioner will be in prescribing specific measures to eliminate or minimize the adverse impacts of development project.

Choice of models/methods for impact predictions in respect to air, noise, water, land, biological and socio-economic environment are precisely tabulated in **Annexure IX**.

4.4.4 Significance of the impacts

Evaluating the significance of environmental effects is perhaps the most critical component of impact analysis. The interpretation of significance bears directly on the subsequent EIA process and also during prior environmental clearance on project approvals and condition setting. At an early stage, it also enters into screening and scoping decisions on what level of assessment is required and which impacts and issues will be addressed.

Impact significance is also a key to choosing among alternatives. In total, the attribution of significance continues throughout the EIA process, from scoping to EIS review, in a gradually narrowing “cone of resolution” in which one stage sets up the next. But at this stage it is the most important as better understanding and quantification of impact significance is required.

One common approach is based on determination of the significance of predicted changes in the baseline environmental characteristics and compares these w.r.t regulatory standards, objective criteria and similar ‘thresholds’ as eco-sensitivity, cultural /religious values. Often, these are outlined in guidance. A better test proposed by the CEAA (1995) is to determine if ‘residual’ environmental effects are adverse, significant, and likely (given under). But at this stage, the practice of formally evaluating significance of residual impacts, *i.e.*, after predicting the nature and magnitude of impacts based on before-versus-after-project comparisons, and identifying measures to mitigate these effects is not being followed in a systematic way.

i. Step 1: Are the environmental effects adverse?

Criteria for determining if effects are “adverse” include:

- effects on biota health
- effects on rare or endangered species
- reductions in species diversity
- habitat loss
- transformation of natural landscapes
- effects on human health
- effects on current use of lands and resources for traditional purposes by aboriginal persons
- foreclosure of future resource use or production

ii. Step 2: Are the adverse environmental effects significant?

Criteria for determining ‘significance’ are to judge that the impacts:

- are extensive over space or time
- are intensive in concentration or proportion to assimilative capacity
- exceed environmental standards or thresholds
- do not comply with environmental policies, land use plans, sustainability strategy
- adversely and seriously affect ecologically sensitive areas
- adversely and seriously affect heritage resources, other land uses, community lifestyle and/or indigenous peoples traditions and values

iii. Step 3: Are the significant adverse environmental effects likely?

Criteria for determining ‘likelihood’ include:

- probability of occurrence, and
- scientific uncertainty

4.5 Social Impact Assessment

Social Impact Assessment (SIA) is an instrument used to analyze social issues and solicit stakeholder views for the design of projects. SIA helps in making the project responsive to social development concerns, including the options that enhance benefits for poor and vulnerable people while mitigating risk and adverse impacts. It analyzes distributional impacts of intended project benefits on different stakeholder groups, and identifies differences in assets and capabilities to access the project benefits.

The scope and depth of the SIA should be determined by the complexity and importance of the issues studied, taking into account the skills and resources available. SIA should include studies related to involuntary resettlement, compulsory land acquisition, impact of imported workforces, job losses among local people, damage to sites of cultural, historic or scientific interest, impact on minority or vulnerable groups, child or bonded labour, use of armed security guards. However, SIA may primarily include the following:

Description of the socio-economic, cultural and institutional profile

Conduct a rapid review of available sources of information to describe the socio-economic, cultural and institutional interface in which the project operates.

Socio-economic and cultural profile: Describe the most significant social, economic and cultural features that differentiate social groups in the project area. Describe their different interests in the project, and their levels of influence. Explain specific effects that the project may have on the poor and underprivileged. Identify any known conflicts among groups that may affect project implementation.

Institutional profile: Describe the institutional environment; consider both the presence and function of public, private and civil society institutions relevant to the operation. Are there important constraints within existing institutions *e.g.* disconnect between institutional responsibilities and the interests and behaviors of personnel within those institutions? Or are there opportunities to utilize the potential of existing institutions, *e.g.* private or civil society institutions, to strengthen implementation capacity.

Legislative and regulatory considerations

To review laws and regulations governing the project's implementation and access of poor and excluded groups to goods, services and opportunities provided by the project. In addition, review the enabling environment for public participation and development planning. SIA should build on strong aspects of legal and regulatory systems to facilitate program implementation and identify weak aspects while recommending alternative arrangements.

Key social issues

SIA provides baseline information for designing the social development strategy. The analysis should determine the key social and institutional issues which affect the project objectives; identify the key stakeholder groups in this context and determine how relationships between stakeholder groups will affect or be affected by the project; and identify expected social development outcomes and actions proposed to achieve those outcomes.

Data collection and methodology

Describe the design and methodology for social analysis. In this regard:

- Build on existing data;
- Clarify the units of analysis for social assessment: intra-household, household level, as well as communities/settlements and other relevant social aggregations on which data is available or will be collected for analysis;
- Choose appropriate data collection and analytical tools and methods, employing mixed methods wherever possible; mixed methods include a mix of quantitative and qualitative methods.

Strategy to achieve social development outcomes

Identify the likely social development outcomes of the project and propose a social development strategy, including recommendations for institutional arrangements to

achieve them, based on the findings of the social assessment. The social development strategy could include measures that:

- strengthen social inclusion by ensuring that both poor and excluded groups and intended beneficiaries are included in the benefit stream; offer access to opportunities created by the project
- that empower stakeholders through their participation in the design and implementation of the project, their access to information, and their increased voice and accountability (*i.e.* a participation framework); and
- enhance security by minimizing and managing likely social risks and increasing the resilience of intended beneficiaries and affected persons to socioeconomic shocks

Implications for analysis of alternatives

Review proposed approaches for the project, and compare them in terms of their relative impacts and social development outcomes. Consider what implications the findings of the social assessment might have on those approaches. Should some new components be added to the approach, or other components be reconsidered or modified?

If SIA and consultation processes indicate that alternative approaches may have better development outcomes, such alternatives should be described and considered, along with the likely budgetary and administrative effects these changes might have.

Recommendations for project design and implementation arrangements

Provide guidance to project management and other stakeholders on how to integrate social development issues into project design and implementation arrangements. As much as possible, suggest specific action plans or implementation mechanisms to address relevant social issues and potential impacts. These can be developed as integrated or separate action plans, for example, as Resettlement Action Plans, Indigenous Peoples Development Plans, Community Development Plans, *etc.*

Developing a monitoring plan

Through SIA process, a framework for monitoring and evaluation should be developed. To the extent possible, this should be done in consultation with key stakeholders, especially beneficiaries and affected people.

The framework shall identify expected social development indicators, establish benchmarks, and design systems and mechanisms for measuring progress and results related to social development objectives. The framework shall identify organizational responsibilities in terms of monitoring, supervision, and evaluation procedures. Wherever possible, participatory monitoring mechanisms shall be incorporated. The framework should establish:

- A set of monitoring indicators to track the progress achieved. The benchmarks and indicators should be limited in number, and should combine both quantitative and qualitative types of data. The indicators for outputs to be achieved by the social development strategy should include indicators to monitor the process of stakeholder participation, implementation and institutional reform

- Indicators to monitor social risk and social development outcomes; and indicators to monitor impacts of the project's social development strategy. It is important to suggest mechanisms through which lessons learnt from monitoring and stakeholder feedback can result in changes to improve the operation of the project. Indicators should be of such a nature that results and impacts can be disaggregated by gender and other relevant social groups;
- define transparent evaluation procedures. Depending on context, these may include a combination of methods, such as participant observation, key informant interviews, focus group discussions, census and socio-economic surveys, gender analysis, Participatory Rural Appraisal (PRA), Participatory Poverty Assessment (PPA) methodologies, and other tools. Such procedures should be tailored to the special conditions of the project and to the different groups living in the project area; Estimate resource and budget requirements for monitoring and evaluation activities, and a description of other inputs (such as institutional strengthening and capacity building) needs to be carried out.

4.6 Risk Assessment

Industrial accidents results in great personal and financial loss. Managing these accidental risks in today's environment is the concern of every industry including chlor-alkali industry, because either real or perceived incidents can quickly jeopardize the financial viability of a business. Many facilities involve various manufacturing processes that have the potential for accidents which may be catastrophic to the plant, work force, environment, or public.

The main objective of risk assessment study is to propose a comprehensive but simple approach to carry out risk analysis and conducting feasibility studies for industries planning and management of industrial prototype hazard analysis study in Indian context.

Risk analysis and risk assessment should provide details on Quantitative Risk Assessment (QRA) techniques used world-over to determine risk posed to people who work inside or live near hazardous facilities, and to aid in preparing effective emergency response plans by delineating a Disaster Management Plan (DMP) to handle onsite and offsite emergencies. Hence, QRA is an invaluable method for making informed risk-based process safety and environmental impact planning decisions, as well as being fundamental to any decision while siting a facility. QRA whether, site-specific or risk-specific for any plant is complex and needs extensive study that involves process understanding, hazard identification, consequence modeling, probability data, vulnerability models/data, local weather and terrain conditions and local population data. QRA may be carried out to serve the following objectives;

- Identification of safety areas
- Identification of hazard sources
- Generation of accidental release scenarios for escape of hazardous materials from the facility
- Identification of vulnerable units with recourse to hazard indices
- Estimation of damage distances for the accidental release scenarios with recourse to Maximum Credible Accident (MCA) analysis
- Hazard and Operability studies (HAZOP) in order to identify potential failure cases of significant consequences
- Estimation of probability of occurrences of hazardous event through fault tree analysis and computation of reliability of various control paths

- Assessment of risk on basis of above evaluation against the risk acceptability criteria relevant to the situation
- Suggest risk mitigation measures based on engineering judgment, reliability and risk analysis approaches
- Delineation / up-gradation of DMP
- Safety Reports: with external safety report/ occupational safety report.

The risk assessment report may cover the following in terms of the extent of damage with resource to MCA analysis and delineation of risk mitigations measures with an approach to DMP.

- Hazard identification – identification of hazardous activities, hazardous materials, past accident records, *etc.*
- Hazard quantification – consequence analysis to assess the impacts
- Risk Presentation
- Risk Mitigation Measures
- DMPs

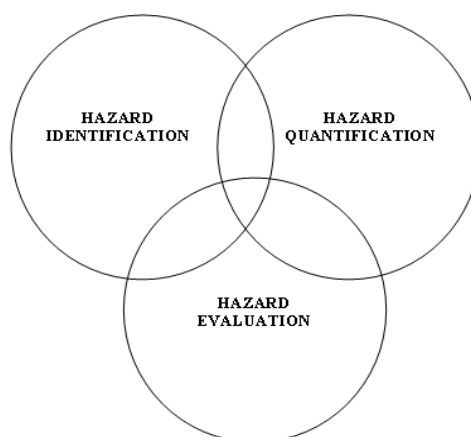

Figure 4-4: Risk Assessment – Conceptual Framework

Methods of risk prediction should cover all the design intentions and operating parameters to quantify risk in terms of probability of occurrence of hazardous events and magnitude of its consequence. Table 4-4 shows the predictive models for risk assessment.

Table 4-4: Choice of Models for Impact Predictions: Risk Assessment

Name	Application	Remarks
EFFECT	Consequence Analysis for Visualization of accidental chemical release scenarios & its consequence	Heat load, press wave & toxic release exposure neutral gas dispersion
WHAZAN	Consequence Analysis for Visualization of accidental chemical release scenarios & its consequence	
EGADIS	Consequence Analysis for Visualization of accidental chemical release scenarios & its consequence	Dense gas dispersion
HAZOP and Fault Tree Assessment	For estimating top event probability	Failure frequency data is required
Pathways reliability and	For estimating reliability of	Markov models

Operational Aspects of EIA

Name	Application	Remarks
protective system hazard analysis	equipments and protective systems	
Vulnerability Exposure models	Estimation of population exposure	Uses probity equation for population exposure
F-X and F-N curves	Individual / Societal risks	Graphical Representation

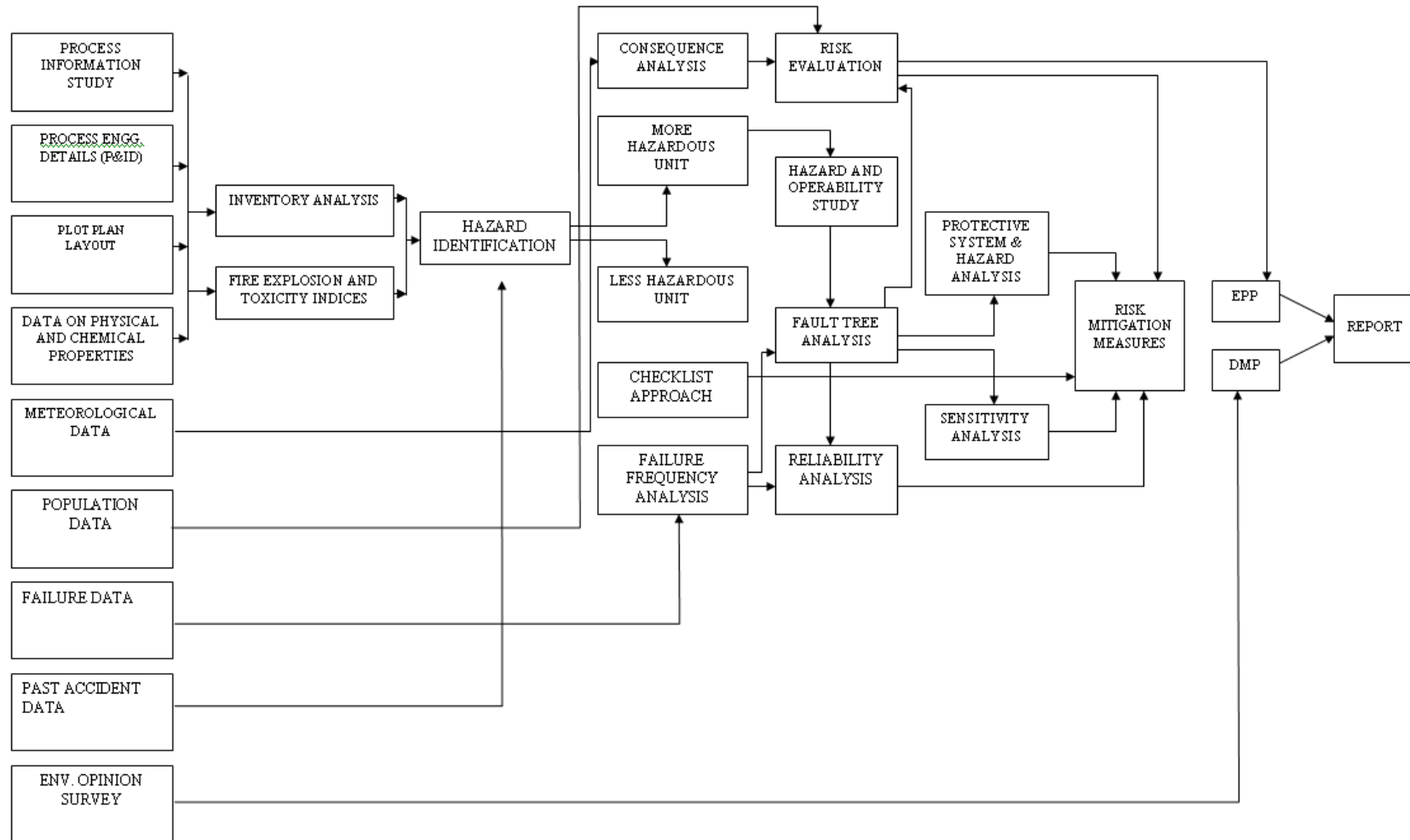

Figure 4-5: Comprehensive Risk Assessment - At a Glance

4.6.1 Storage and handling of hazardous materials

Both hazardous and non-hazardous materials generated within the project facility shall be temporarily accommodated in appropriate units placed within the project facility built/made in line with the safety, health and environmental standards.

The size of these temporary units would depend on the quantity and type of hazardous waste materials like asbestos, PCB, oils, fuels, *etc.*, with appropriate storage capacities placed in the project facility in compliance with the Hazardous Waste Management and Handling Rules. In case of radioactive wastes, storage and handling should be based on Rules for Management of Radioactive Waste under AERB. Also, if gas cylinders must be stored in the facility, rules applicable for gas cylinders under the Explosives Act shall be followed. Later, these materials must be disposed off at a centralized disposal facility with utmost care following safety norms. Each unit in the facility should have a fire hydrant system to handle fire hazards.

4.6.2 Hazard identification

Hazard is the characteristic of any system or process which has the potential for accident. Identification of hazards, in presence of any hazardous waste generating units within the project facility is of primary significance in the analysis, quantification and cost-effective control of accidents involving chemicals and process.

Hence, all components of a system/unit need to be thoroughly examined to assess their potential for initiating or propagating an unplanned event/sequence of events, which can be termed as an accident.

Typical methods for hazard identification employed are:

- Identification of major hazardous units based on Manufacture, Storage and Import of Hazardous Chemicals Rules, 1989 of Government of India (as amended in 2000)
- Identification of hazardous units and segments of plants and storage units based on relative ranking technique, viz. Fire-Explosion and Toxicity Index (FE&TI).

Hazardous substances may be classified into three main categories namely flammable, unstable and toxic substances. Flammable substances require interaction with air for their hazard to be realized. Under certain circumstances, vapours arising from flammable substances when mixed with air may become explosive, especially in confined spaces. However, if present in sufficient quantity, such clouds may explode in open air also. Unstable substances are liquids or solids, which may decompose with such violence giving rise to blast waves. Besides, toxic substances are dangerous and cause substantial damage to life when released into the atmosphere. The ratings for a large number of chemicals based on flammability, reactivity and toxicity are provided in NFPA Codes 49 and 345 M.

4.6.3 Hazard assessment and evaluation

A preliminary hazard analysis shall be carried out to identify major hazards associated with storages in the facility. This is followed by consequence analysis to quantify these hazards. Finally the vulnerable zones are plotted for which risk reducing measures are deduced and implemented.

Frequent causes of accidents

- Fire and explosion: explosives, flammable material
- Being struck by falling objects
- Caught in/compressed
- Snapping of cables, ropes, chains, slings
- Handling heavy objects
- Electricity (electrocution)
- Poor illumination
- Falls from height inside industrial units or on the ground
- Struck by moving objects
- Slipping on wet surfaces
- Sharp objects
- Oxygen deficiency in confined spaces
- Lack of personal protective equipment (PPE), housekeeping practices, safety signs
- Hackles, hooks, chains
- Cranes, winches, hoisting and hauling equipment;

Hazardous substances and wastes

- Heavy and toxic metals (lead, mercury, cadmium, copper, zinc, *etc.*)
- Organometallic substances (tributyltin, *etc.*)
- Lack of hazard communication (storage, labelling, material safety data sheets)
- Batteries, fire-fighting liquids
- PCBs and PVC (combustion products)
- Welding fumes
- Volatile organic compounds (solvents)
- Inhalation in confined and enclosed spaces
- Physical hazards
- Noise
- Extreme temperatures
- Vibration
- Radiation (UV, radioactive materials)

Physical hazards

- Noise
- Extreme temperatures
- Vibration
- Radiation (UV, radioactive materials)

Mechanical hazards

- Trucks and transport vehicles
- Scaffolding, fixed and portable ladders
- Impact by tools, sharp-edged tools
- Power-driven hand tools, saws, grinders and abrasive cutting wheels
- Failure of machinery and equipment
- Poor maintenance of machinery and equipment
- Lack of safety guards in machines
- Structural failure

Biological hazards

- Toxic marine organisms (If the project facility is located in Coastal Regions)
- Risk of communicable diseases transmitted by pests, vermin, rodents, insects and other animals that may infest the project facility.
- Animal bites
- Vectors of infectious diseases (TB, malaria, dengue fever, hepatitis, respiratory infections, others)

Ergonomic and psychosocial hazards

- Repetitive strain injuries, awkward postures, repetitive and monotonous work, excessive workload
- Long working hours, shift work, night work, temporary employment
- Mental stress, human relations (aggressive behaviour, alcohol and drug abuse, violence)
- Poverty, low wages, minimum age, lack of education and social environment

General concerns

- Lack of safety and health training
- Poor work organization
- Inadequate housing and sanitation
- Inadequate accident prevention and inspection
- Inadequate emergency, first-aid and rescue facilities
- Lack of medical facilities and social protection

4.6.4 Disaster management plan

A disaster is a catastrophic situation in which suddenly, people are plunged into helplessness and suffering and, as a result, need protection, clothing, shelter, medical & social care and other necessities of life.

The Disaster Management Plan (DMP) is aimed to ensure safety of life, protection of environment, protection of installation, restoration of production and salvage operations in this same order of priorities. For effective implementation of DMP, it should be widely circulated and a personnel training is to be provided through rehearsals/drills.

To tackle the consequences of a major emergency inside the plant or immediate vicinity of the plant, a DMP has to be formulated and this planned emergency document is called DMP.

The objective of the DMP is to make use of the combined resources of the plant and the outside services to achieve the following:

- Effective rescue and medical treatment of casualties
- Safeguard other people
- Minimize damage to property and the environment
- Initially contain and ultimately bring the incident under control
- Identify any dead
- Provide for the needs of relatives
- Provide authoritative information to the news media
- Secure the safe rehabilitation of affected area

- Preserve relevant records and equipment for the subsequent inquiry into the cause and circumstances of the emergency

In effect, it is to optimize operational efficiency to rescue rehabilitation and render medical help and to restore normalcy.

The DMP should include emergency preparedness plan, emergency response team, emergency communication, emergency responsibilities, emergency facilities, and emergency actions

4.6.4.1 Emergency preparedness plan

Incidents, accidents and contingency preparedness should be accounted during construction and operation process. This shall be a part of EMS. Emergency Preparedness Plan (EPP) should be prepared following the National Environmental Emergency Plan and OSHA guidelines. According to these guidelines, an environmental emergency plan would essentially provide the following information:

- Assignment of duties and responsibilities among the authorities, participating agencies, response team, their coordinators and/or those responsible for the pollution incident
- Relationship with other emergency plans
- A reporting system that ensures rapid notification in the event of a pollution incident
- The establishment of a focal point for coordination and directions connected to the implementation of the plan
- Response operations should always cover these four phases:
 - Discovery and alarm
 - Evaluation, notification and plan invocation
 - Containment and counter measures
 - Cleanup and disposal
- Identification of expertise and response resources available for assistance for the implementation of plan
- Directions on the necessary emergency provisions applicable to the handling, treatment or disposal of certain pollutants
- Link to the local community for assistance, if necessary
- Support measures, such as procedures for providing public information, carrying out surveillance, issuing post-incident reports, review and updating of the plan, and periodic exercising of the plan.

4.6.4.2 Emergency response

Various units within the project facility are always subjected to accidents and incidents of many a kind. Therefore, a survey of potential incidents and accidents is to be carried out. Based on this, a plan for response to incidents, injuries and emergencies should be prepared. Response to emergencies should ensure that:

- The exposure of workers should be limited as much as possible during the operation

- Contaminated areas should be cleaned and, if necessary disinfected
- Limited impact on the environment at the extent possible.

Written procedures for different types of emergencies should be prepared and the entire workforce should be trained in emergency response. All relevant emergency response equipment should also be readily available.

With regard to dangerous spills, associated cleanup and firefighting operations should be carried out by specially allocated and trained personnel.

4.6.4.3 Response team

It is important to setup an Emergency Organization. A senior executive who has control over the affairs of the plant would be heading the Emergency Organization. He would be designated as Site Controller. Manager (Safety) would be designated as the Incident Controller. In case of stores, utilities, open areas, which are not under control of the Production Heads, Senior Executive responsible for maintenance of utilities would be designated as Incident Controller. All the Incident Controllers would be reporting to the Site Controller.

Each Incident Controller organizes a team responsible for controlling the incidence with the personnel under his control. Shift in charge would be the reporting officer, who would bring the incidence to the notice of the Incidence Controller and Site Controller.

Emergency Coordinators would be appointed who would undertake the responsibilities like firefighting, rescue, rehabilitation, transport and provide essential & support services. For this purposes, Security In charge, Personnel Department, Essential services personnel would be engaged. All these personnel would be designated as key personnel.

In each shift, electrical supervisor, electrical fitters, pump house in charge, and other maintenance staff would be drafted for emergency operations. In the event of power or communication system failure, some of staff members in the office/facility would be drafted and their services would be utilized as messengers for quick passing of communications. All these personnel would be declared as essential personnel.

4.6.4.4 Response to injuries

Based on a survey of possible injuries, a procedure for response to injuries or exposure to hazardous substances should be established. All staff should have minimum training to such response and the procedure ought to include the following:

- Immediate first aid, such as eye splashing, cleansing of wounds and skin, and bandaging
- Immediate reporting to a responsible designated person
- If possible, retention of the item and details of its source for identification of possible hazards
- Rapid additional medical care from medical personnel
- Medical surveillance
- Recording of the incident

- Investigation, determination and implementation of remedial action

It is vital that incident reporting should be straightforward so that reporting is actually carried out.

4.6.4.5 Emergency communication

Whoever notices an emergency situation such as fire, growth of fire, leakage, *etc.* would inform his immediate superior and Emergency Control Center. The person on duty in the Emergency Control Center, would appraise the Site Controller. Site Controller verifies the situation from the Incident Controller of that area or the Shift In charge and takes a decision about an impending On-site Emergency. This would be communicated to all the Incident Controllers, Emergency Coordinators. Simultaneously, the emergency warning system would be activated on the instructions of the Site Controller.

4.6.4.6 Emergency responsibilities

Responsibilities of the following key personnel should be defined:

- Site controller
- Incident controller
- Emergency coordinator - rescue, fire fighting
- Emergency coordinator-medical, mutual aid, rehabilitation, transport and communication
- Emergency coordinator - essential services
- Employers responsibility

4.6.4.7 Emergency facilities

- Emergency Control Center – with access to important personnel, telephone, fax, telex facility, safe contained breathing apparatus, hand tools, emergency shut down procedures, duties and contact details of key personnel and government agencies, emergency equipments, *etc.*
- Assembly Point – with minimum facilities for safety and rescue
- Emergency Power Supply – connected with diesel generator, flame proof emergency lamps, *etc.*
- Fire Fighting Facilities – first aid fire fighting equipments, fire alarms, *etc.*
- Location of wind Stock – located at appropriate location to indicate the direction of wind for emergency escape
- Emergency Medical Facilities – Stretchers, gas masks, general first aid, emergency control room, breathing apparatus, other emergency medical equipment, ambulance

4.6.4.8 Emergency actions

- Emergency warning
- Evacuation of personnel
- All clear signal
- Public information and warning

- Coordination with local authorities
- Mutual aid
- Mock drills

4.7 Mitigation Measures

The purpose of mitigation is to identify measures that safeguard the environment and the community affected by the proposal. Mitigation is both a creative and practical phase of the EIA process. It seeks to find the best ways and means of avoiding, minimizing and remedying impacts. Mitigation measures must be translated into action in right way and at the right time, if they are to be successful. This process is referred to as impact management and takes place during project implementation. A written plan should be prepared for this purpose, and should include a schedule of agreed actions. Opportunities for impact mitigation will occur throughout the project cycle.

4.7.1 Important considerations for mitigation methods

The responsibility of project proponents to ‘internalize’ the full environmental costs of development proposals is now widely accepted under “Polluter Pay” principle. In addition, many proponents have found that good design and impact management can result in significant savings applying the principles of cleaner production to improve their environmental performance.

- The predicted adverse environmental as well as social impacts for which mitigation measures are required should be identified and briefly summarized along with cross referencing them to the significance, prediction components of the EIA report or other documentation.
- Each mitigation measure should be briefly described w.r.t the impact of significances to which it relates and the conditions under which it is required (for example, continuously or in the event of contingencies). These should also be cross-referenced to the project design and operating procedures which elaborate on the technical aspects of implementing the various measures.
- Cost and responsibilities for mitigation and monitoring should be clearly defined, including arrangements for co-ordination among various Authorities responsible for mitigation.
- The proponent can use the EMP to develop environmental performance standards and requirements for the project site as well as supply chain. An EMP can be implemented through EMS for the operational phase of the project.

Prior to selecting mitigation plans it is appropriate to study the mitigation alternatives for cost-effectiveness, technical and socio-political feasibility. Such mitigation measures could include:

- avoiding sensitive areas such as eco-sensitive area *e.g.* fish spawning areas, dense mangrove areas or areas known to contain rare or endangered species
- adjusting work schedules to minimize disturbance
- engineered structures such as berms and noise attenuation barriers
- pollution control devices such as scrubbers and electrostatic precipitators
- changes in fuel feed, manufacturing, process, technology use, or waste management practices, *etc.*

4.7.2 Hierarchy of elements of mitigation plan

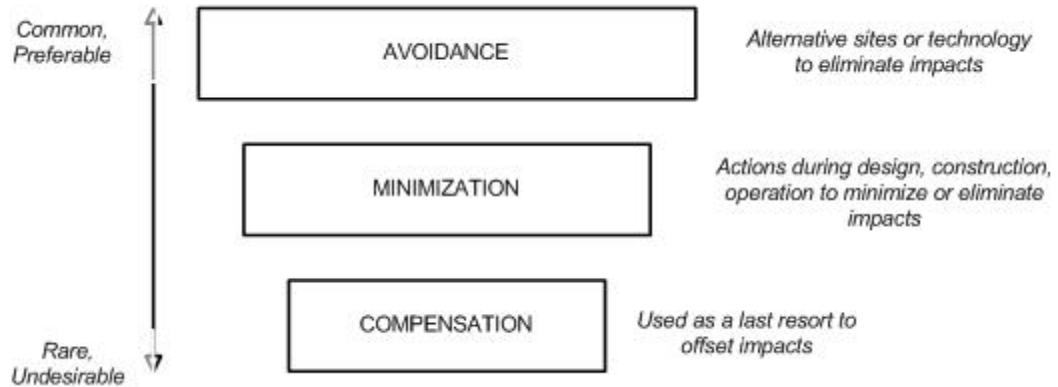

Figure 4-6: Elements of Mitigation

A good EIA practice requires technical understanding of relevant issues and the measures that work in such given circumstances: The priority of selection of mitigation measures should be in the order:

Step One: Impact avoidance

This step is most effective when applied at an early stage of project planning. It can be achieved by:

- not undertaking certain projects or elements that could result in adverse impacts
- avoiding areas that are environmentally sensitive
- putting in place the preventative measures to stop adverse impacts from occurring, for example, release of water from a reservoir to maintain a fisheries regime

Step Two: Impact minimization

This step is usually taken during impact identification and prediction to limit or reduce the degree, extent, magnitude, or duration of adverse impacts. It can be achieved by:

- scaling down or relocating the proposal
- redesigning elements of the project
- taking supplementary measures to manage the impacts

Step Three: Impact compensation

This step is usually applied to remedy unavoidable residual adverse impacts. It can be achieved by:

- rehabilitation of the affected site or environment, for example, by habitat enhancement and restocking fish
- restoration of the affected site or environment to its previous state or better, as typically required for mine sites, forestry roads and seismic lines
- replacement of the same resource values at another location. For example, by wetland engineering to provide an equivalent area to that lost to drainage or infill

Important compensation elements

Resettlement Plans: Special considerations apply to mitigation of proposals that displace or disrupt people. Certain types of projects, such as reservoirs and irrigation schemes and public works, are known to cause involuntary resettlement. This is a contentious issue because it involves far more than re-housing people; in addition, income sources and access to common property resources are likely to be lost. Almost certainly, a resettlement plan will be required to ensure that no one is worse off than before, which may not be possible for indigenous people whose culture and lifestyle is tied to a locality. This plan must include the means for those displaced to reconstruct their economies and communities and should include an EIA of the receiving areas. Particular attention should be given to indigenous, minority and vulnerable groups who are at higher risk from resettlement.

In-kind compensation

When significant or net residual loss or damage to the environment is likely, in kind compensation is appropriate. As noted earlier, environmental rehabilitation, restoration or replacement have become standard practices for many proponents. Now, increasing emphasis is given to a broader range of compensation measures to offset impacts and assure the sustainability of development proposals. These include impact compensation 'trading', such as offsetting CO₂ emissions by planting forests to sequester carbon.

4.7.3 Typical mitigation measures

Choice of location for the developmental activity plays an important role in preventing adverse impacts on the surrounding environment. Detailed guidelines on siting of industries are provided in Section 4.2. However, if the developmental activity produces any adverse impacts, mitigation measures should be taken.

Previous subsections of the Section 4.7 could be precisely summarized into following:

- Impacts from a developmental project could have many dimensions. As most of the direct impacts are caused by releases from developmental projects, often control at source is the best opportunity to either eliminate or mitigate impacts, in case these are cost-effective. In other words, the best way to mitigate impacts is to prevent them from occurring. Choice of raw materials/technologies/processes which produce least impact would be one of the options to achieve it.
- After exploring cost-effective feasible alternatives to control impacts at source, various interventions to minimize the adverse impacts may be considered. These interventions, primarily aim at reducing the residual impacts on the VECs of the receiving environment to acceptable concentrations.
- Degree of control at source and external interventions differs from situation-to-situation and is largely governed by techno-economic feasibility. While the regulatory bodies stress for further source control (due to high reliability), the project proponents bargain for other interventions which may be relatively cost-effective than further control at source (in any case project authority is required to meet the industry-specific standards by adopting the best practicable technologies. However, if the location demands further control at source, then the proponents are required to adopt further advanced control technologies *i.e.* towards best available control technologies). After having discussions with the project proponent, EAC/SEAC reaches to an agreed level of source control+other interventions (together called as

mitigation measures in the given context) that achieve the targeted protection levels for the VECs in the receiving environment. These levels will become the principal clearance conditions.

- Chapter 3 of this TGM offers elaborate information on cleaner technologies, waste minimization opportunities, and control technologies for various kinds of polluting parameters that emanate from this developmental activity. This information may be used to draw appropriate control measures applicable at source.

The choice of interventions for mitigation of impacts may also be numerous and depend on various factors. Mitigation measures based on location-specific suitability and some other factors are discussed in sub-sections 4.7.1 and 4.7.2. A few typical measures which may also be explored for mitigation of impacts are listed in Table 4-5.

Table 4-5: Typical Mitigation Measures

Impacts	Typical Mitigation Measures
Soil erosion	<ul style="list-style-type: none"> ▪ Windscreens, maintenance, and installation of ground cover ▪ Installation of drainage ditches ▪ Runoff and retention ponds ▪ Minimize disturbances and scarification of the surface
Resources – fuel/construction material	<ul style="list-style-type: none"> ▪ Optimization of resource use ▪ Availing resources with least impact – eco-efficiency options are applicable ▪ Availing the resources which could be replenished by natural systems, <i>etc.</i>
Deforestation	<ul style="list-style-type: none"> ▪ Plant or create similar areas ▪ Initiate a tree planning program in other areas ▪ Donate land to conservationist groups
Water pollution	<ul style="list-style-type: none"> ▪ Conjunctive use of ground/surface water, to prevent flooding/water logging/depletion of water resources. Included are land use pattern, land filling, lagoon/reservoir/garland canal construction, and rainwater harvesting and pumping rate. ▪ Minimise flow variation from the mean flow ▪ Storing of oil wastes in lagoons should be minimised in order to avoid possible contamination of the ground water system. ▪ All effluents containing acid/alkali/organic/toxic wastes should be properly treated. ▪ Monitoring of ground waters ▪ Use of biodegradable or otherwise readily treatable additives ▪ Neutralization and sedimentation of wastewaters, where applicable ▪ Dewatering of sludges and appropriate disposal of solids ▪ In case of oil waste, oil separation before treatment and discharge into the environment ▪ By controlling discharge of sanitary sewage and industrial waste with suspended solids into the environment ▪ By avoiding the activities that increases erosion or that contributes nutrients to water (thus stimulating alga growth) ▪ For wastes containing high TDS, treatment methods include removal of liquid and disposal of residue by controlled landfilling to avoid any possible leaching of the fills ▪ All surface runoffs around mines or quarries should be collected treated and disposed. ▪ Treated wastewater (such as sewage, industrial wastes, or stored surface runoffs) can be used as cooling water makeup.

Impacts	Typical Mitigation Measures
	<ul style="list-style-type: none"> ▪ Wastewater carrying radioactive elements should be treated separately by means of de-watering procedures, and solids or brine should be disposed of with special care. ▪ Develop spill prevention plans in case of chemical discharges and spills ▪ Develop traps and containment system and chemically treat discharges on site
Air Pollution	<ul style="list-style-type: none"> ▪ Attenuation of pollution/protection of receptor through green belts/green cover ▪ Use of particulate removal devices such as cyclones, setting chambers, scrubbers, electrostatic precipitators, bag houses, <i>etc.</i> ▪ Use of gas removal devices using absorption (liquid as a media), adsorption (molecular sieve), and catalytic converters ▪ Use of protected, controlled equipments such as oxygen masks, houston astrodome, <i>etc.</i> ▪ Control of stationary source emission (including evaporation, incineration, absorption, condensation, and material substitution) ▪ Dilution of odourant (dilution can change the nature as well as strength of an odour), odour counteraction or neutralise (certain pairs of odours in appropriate concentrations may neutralise each other), odour masking or blanketing (certain weaker malodours may be suppressed by a considerably stronger good odour). ▪ Regular monitoring of air polluting concentrations
Dust pollution	<ul style="list-style-type: none"> ▪ Wetting of roadways to reduce traffic dust and re-entrained particles ▪ Installation of windscreens to breakup the wind flow ▪ Burning of refuse on days when meteorological conditions provide for good mixing and dispersion ▪ Providing dust collection equipment at all possible points ▪ Maintaining dust levels within permissible limits ▪ Provision for masks when dust level exceeds
Noise pollution	<ul style="list-style-type: none"> ▪ Limiting certain activities ▪ By using damping, absorption, dissipation, and deflection methods ▪ By using common techniques such as constructing sound enclosures, applying mufflers, mounting noise sources on isolators, and/or using materials with damping properties ▪ Performance specifications for noise represent a way to insure the procured item is controlled ▪ Use of ear protective devices. ▪ In case of steady noise levels above 85-dB (A), initiation of hearing conservation measures
Biological	<ul style="list-style-type: none"> ▪ Installation of systems to discourage nesting or perching of birds in dangerous environments ▪ Increased employee awareness to sensitive areas
Social	<ul style="list-style-type: none"> ▪ Health and safety measures for workers ▪ Development of traffic plan that minimizes road use by workers ▪ Upgrade roads and intersections
Marine environment	<ul style="list-style-type: none"> ▪ Water quality monitoring program ▪ Appropriate system to barges/workboats for collection of liquid/solid waste generated onboard ▪ Checking with the complainance conditions before discharging

4.8 Environmental Management Plan

A typical EMP shall be composed of the following:

1. summary of potential impacts of the proposal
2. description of recommended mitigation measures
3. description of monitoring programme to ensure compliance with relevant standards and residual impacts
4. allocation of resources and responsibilities for plan implementation
5. implementation schedule and reporting procedures
6. contingency plan when impacts are greater than expected

Summary of impacts: The predicted adverse environmental and social impacts for which mitigation measures are identified in earlier sections to be briefly summarized with cross referencing to the corresponding sections in EIA report.

Description of mitigation measures: Each mitigation measure should be briefly described w.r.t the impact to which it relates and the conditions under which it is required. These should be accompanied by, or referenced to, project design and operating procedures which elaborate on the technical aspects of implementing the various measures.

Description of monitoring programme to ensure compliance with relevant standards and residual impacts: Environmental monitoring refers to compliance monitoring and residual impact monitoring. Compliance monitoring refers to meeting the industry-specific statutory compliance requirements (Ref. Applicable National regulations as detailed in Chapter 3).

Residual impact monitoring refers to monitoring of identified sensitive locations with adequate number of samples and frequency. The monitoring programme should clearly indicate the linkages between impacts identified in the EIA report, measurement indicators, detection limits (where appropriate), and definition of thresholds that will signal the need for corrective actions.

Allocation of resources and responsibilities for plan implementation: These should be specified for both the initial investment and recurring expenses for implementing all measures contained in the EMP, integrated into the total project costs, and factored into loan negotiation.

The EMP should contain commitments that are binding on the proponent in different phases of project implementation *i.e.*, pre-construction or site clearance, construction, operation, decommissioning.

Responsibilities for mitigation and monitoring should be clearly defined, including arrangements for coordination between the various factors responsible for mitigation. Details should be provided w.r.t deployment of staff (detailed organogram), monitoring network design, parameters to be monitored, analysis methods, associated equipments, *etc.*

Implementation schedule and reporting procedures: The timing, frequency and duration of mitigation measure should be specified in an implementation schedule,

showing links with overall project implementation. Procedures to provide information on the progress and results of mitigation and monitoring measures should also be clearly specified.

Contingency Plan when the impacts are greater than expected: There shall be a contingency plan for attending the situations where the residual impacts are higher than expected. It is an imperative requirement for all project Authorities to plan additional programmes to deal with the situation, after duly intimating the concerned local regulatory bodies.

4.9 Reporting

Structure of the EIA report (Appendix III of the EIA Notification) applicable for chlor-alkali industry is given in the Table 4.6. Each task prescribed in ToR shall be incorporated appropriately in the contents in addition to the contents described in the Table.

Table 4-6: Structure of EIA Report

S.NO	EIA STRUCTURE	CONTENTS
1.	Introduction	<ul style="list-style-type: none"> ▪ Purpose of the report ▪ Identification of project & project proponent ▪ Brief description of nature, size, location of the project and its importance to the country, region ▪ Scope of the study – details of regulatory scoping carried out (As per Terms of Reference)
2.	Project Description	<p>Condensed description of those aspects of the project (based on project feasibility study), likely to cause environmental effects. Details should be provided to give clear picture of the following:</p> <ul style="list-style-type: none"> ▪ Type of project ▪ Need for the project ▪ Location (maps showing general location, specific location, project boundary & project site layout) ▪ Size or magnitude of operation (incl. Associated activities required by or for the project) ▪ Proposed schedule for approval and implementation ▪ Technology and process description ▪ Project description including drawings showing project layout, components of project <i>etc.</i> Schematic representations of the feasibility drawings which give information important for EIA purpose ▪ Description of mitigation measures incorporated into the project to meet environmental standards, environmental operating conditions, or other EIA requirements (as required by the scope) ▪ Assessment of new & untested technology for the risk of technological failure
3.	Description of the Environment	<ul style="list-style-type: none"> ▪ Study area, period, components & methodology ▪ Establishment of baseline for VECs, as identified in the scope ▪ Base maps of all environmental components
4.	Anticipated Environmental	<ul style="list-style-type: none"> ▪ Details of Investigated Environmental impacts due to project location, possible accidents, project design, project construction, regular operations, final decommissioning or

S.NO	EIA STRUCTURE	CONTENTS
	Impacts & Mitigation Measures	<ul style="list-style-type: none"> rehabilitation of a completed project Measures for minimizing and / or offsetting adverse impacts identified Irreversible and irretrievable commitments of environmental components Assessment of significance of impacts (Criteria for determining significance, Assigning significance) Mitigation measures
5.	Analysis of Alternatives (Technology & Site)	<ul style="list-style-type: none"> Incase, the scoping exercise results in need for alternatives: Description of each alternative Summary of adverse impacts of each alternative Mitigation measures proposed for each alternative and selection of alternative
6.	Environmental Monitoring Program	<ul style="list-style-type: none"> Technical aspects of monitoring the effectiveness of mitigation measures (incl. measurement methodologies, frequency, location, data analysis, reporting schedules, emergency procedures, detailed budget & procurement schedules)
7.	Additional Studies	<ul style="list-style-type: none"> Public consultation Risk assessment Social impact assessment, R&R action plans
8.	Project Benefits	<ul style="list-style-type: none"> Improvements in physical infrastructure Improvements in social infrastructure Employment potential –skilled; semi-skilled and unskilled Other tangible benefits
9.	Environmental Cost Benefit Analysis	<ul style="list-style-type: none"> If recommended at the scoping stage
10.	EMP	<ul style="list-style-type: none"> Description of the administrative aspects that ensures proper implementation of mitigative measures and their effectiveness monitored, after approval of the EIA
11.	Summary & Conclusion (This will constitute the summary of the EIA Report)	<ul style="list-style-type: none"> Overall justification for implementation of the project Explanation of how, adverse effects have been mitigated
12.	Disclosure of Consultants engaged	<ul style="list-style-type: none"> The names of the Consultants engaged with their brief resume and nature of Consultancy rendered

4.10 Public Consultation

Public consultation refers to the process by which the concerns of local affected people and others who have plausible stake in the environmental impacts of the project or activity are ascertained.

- Public consultation is not a decision taking process, but is a process to collect views of the people having plausible stake. If the SPCB/Public agency conducting public hearing is not convinced with the plausible stake, then such expressed views need not be considered.
- Public consultation involves two components, one is public hearing, and other one is inviting written responses/objections through Internet/by post, *etc.*, by placing the summary of EIA report on the website.

- All Category A and Category B1 projects require public hearing except the following:
 - Once prior environmental clearance is granted to an industrial estates/SEZs/EPZs *etc.*, for a given composition (type and capacity) of industries, then individual units will not require public hearing
 - Expansion of roads and highways, which do not involve any further acquisition of land.
 - Maintenance dredging provided the dredged material shall be disposed within port limits
 - All building/construction projects/area development projects/townships
 - All Category B2 projects
 - All projects concerning national defense and security or involving other strategic considerations as determined by the Central Government
- Public hearing shall be carried out at the site or in its close proximity, district-wise, for ascertaining concerns of local affected people.
- Project proponent shall make a request through a simple letter to the Member–Secretary of the SPCB/UTPCC to arrange public hearing.
- Project proponent shall enclose with the letter of request, at least 10 hard copies and 10 soft copies of the draft EIA report including the summary EIA report in English and in the official language of the State/local language prepared as per the approved scope of work, to the concerned Authority.
- Simultaneously, project proponent shall arrange to send, one hard copy and one soft copy, of the above draft EIA report along with the summary EIA report to the following Authorities within whose jurisdiction the project will be located:
 - District magistrate/District Collector/Deputy Commissioner (s)
 - Zilla parishad and municipal corporation or panchayats union
 - District industries office
 - Urban local bodies (ULBs)/PRIs concerned/development authorities
 - Concerned regional office of the MoEF/SPCB
- Above mentioned Authorities except regional office of MoEF shall arrange to widely publicize the draft EIA report within their respective jurisdictions requesting the interested persons to send their comments to the concerned regulatory authorities. They shall also make draft EIA report for inspection electronically or otherwise to the public during normal office hours till the public hearing is over.
- Concerned regulatory Authority (MoEF/SEIAA/UTEIA) shall display the summary of EIA report on its website and also make full draft EIA report available for reference at a notified place during normal office hours at their head office.
- SPCB or UTPCC concerned shall also make similar arrangements for giving publicity about the project within the State/UT and make available the summary of draft EIA report for inspection in select offices, public libraries or any other suitable location, *etc.* They shall also additionally make available a copy of the draft EIA report to the above five authorities/offices as mentioned above.
- The Member–Secretary of the concerned SPCB or UTPCC shall finalize the date, time and exact venue for the conduct of public hearing within seven days of the date of the receipt of the draft EIA report from the project proponent and advertise the same in one major National Daily and one Regional vernacular Daily/official State language.

- A minimum notice period of 30 (thirty) days shall be provided to the public for furnishing their responses.
- No postponement of the date, time, venue of the public hearing shall be undertaken, unless some untoward emergency situation occurs and then only on the recommendation of the concerned District Magistrate/District Collector/Deputy Commissioner, the postponement shall be notified to the public through the same National and Regional vernacular dailies and also prominently displayed at all the identified offices by the concerned SPCB/ UTPCC
- In the above exceptional circumstances fresh date, time and venue for the public consultation shall be decided by the Member–Secretary of the concerned SPCB/ UTPCC only in consultation with the District Magistrate/District Collector/Deputy Commissioner and notified afresh as per the procedure.
- The District Magistrate/District Collector/Deputy Commissioner or his or her representative not below the rank of an Additional District Magistrate assisted by a representative of SPCB or UTPCC, shall supervise and preside over the entire public hearing process.
- The SPCB/UTPCC shall arrange to video film the entire proceedings. A copy of the videotape or a CD shall be enclosed with the public hearing proceedings while forwarding it to the Regulatory Authority concerned.
- The attendance of all those who are present at the venue shall be noted and annexed with the final proceedings
- There shall be *no quorum* required for attendance for starting the proceedings
- Persons present at the venue shall be granted the opportunity to seek information or clarifications on the project from the proponent. The summary of the public hearing proceedings accurately reflecting all the views and concerns expressed shall be recorded by the representative of the SPCB/UTPCC and read over to the audience at the end of the proceedings explaining the contents in the local/vernacular language and the agreed minutes shall be signed by the District Magistrate/District Collector/Deputy Commissioner or his or her representative on the same day and forwarded to the SPCB/UTPCC concerned.
- A statement of the issues raised by the public and the comments of the proponent shall also be prepared in the local language or the official State language, as the case may be and in English and annexed to the proceedings.
- The proceedings of the public hearing shall be conspicuously displayed at the office of the Panchayats within whose jurisdiction the project is located, office of the concerned Zilla Parishad, District Magistrate/District Collector/Deputy Commissioner, and the SPCB or UTPCC. The SPCB/ UTPCC shall also display the proceedings on its website for general information. Comments, if any, on the proceedings, may be sent directly to the concerned regulatory authorities and the Applicant concerned.
- The public hearing shall be completed within a period of 45 (forty five) days from date of receipt of the request letter from the Applicant. Therefore the SPCB or UTPCC concerned shall send the public hearing proceedings to the concerned regulatory authority within 8(eight) days of the completion of the public hearing. Simultaneously, a copy will also be provided to the project proponent. The proponent may also directly forward a copy of the approved public hearing proceedings to the regulatory authority concerned along with the final EIA report or supplementary report to the draft EIA report prepared after the public hearing and public

consultations incorporating the concerns expressed in the public hearing along with action plan and financial allocation, item-wise, to address those concerns.

- Upon receipt of the same, the Authority will place executive summary of the report on the website to invite responses from other concerned persons having a plausible stake in the environmental aspects of the project or activity.
- If SPCB/UTPCC is unable to conduct the public hearing in the prescribed time, the Central Government in case of Category A projects and State Government or UT administration in case of Category B projects at the request of the SEIAA can engage any other agency or Authority for conducting the public hearing process within a further period of 45 days. The respective governments shall pay the appropriate fee to the public agency for conducting public hearing.
- A public agency means a non-profit making institution/ body such as technical/academic institutions, government bodies not subordinate to the concerned Authority.
- If SPCB/Public Agency authorized for conducting public hearing informs the Authority, stating that it is not possible to conduct the public hearing in a manner, which will enable the views of the concerned local persons to be freely expressed, then Authority may consider such report to take a decision that in such particular case, public consultation may not have the component of public hearing.
- Often restricting the public hearing to the specific district may not serve the entire purpose, therefore, NGOs who are local and registered under the Societies Act in the adjacent districts may also be allowed to participate in public hearing, if they so desire.
- Confidential information including non-disclosable or legally privileged information involving intellectual property right, source specified in the application shall not be placed on the website.
- The Authority shall make available on a written request from any concerned person the draft EIA report for inspection at a notified place during normal office hours till the date of the public hearing.
- While mandatory requirements will have to be adhered to, utmost attention shall be given to the issues raised in the public hearing for determining the modifications needed in the project proposal and the EMP to address such issues.
- Final EIA report after making needed amendments, as aforesaid, shall be submitted by the applicant to the concerned Authority for prior environmental clearance. Alternatively, a supplementary report to draft EIA and EMP addressing all concerns expressed during the public consultation may be submitted.

4.11 Appraisal

Appraisal means the detailed scrutiny by the EAC/SEAC of the application and the other documents like the final EIA report, outcome of the public consultation including public hearing proceedings submitted by the applicant for grant of prior environmental clearance.

- Appraisal shall be made by EAC to the Central Government or SEAC to SEIAA.
- Project proponent either personally or through consultant can make a presentation to EAC/SEAC for the purpose of appraising the features of the project proposal and also to clarify the issues raised by the members of the EAC/SEAC.

- On completion of these proceedings, concerned EAC/SEAC shall make categorical recommendations to the respective Authority, either for grant of prior environmental clearance on stipulated terms & conditions, if any, or rejection of the application with reasons.
- In case EAC/SEAC needs to visit the site or obtain further information before being able to make categorical recommendations, EAC/SEAC may inform the project proponent accordingly. In such an event, it should be ensured that the process of prior environmental clearance is not unduly delayed to go beyond the prescribed timeframe.
- Upon the scrutiny of the final report, if EAC/SEAC opines that ToR for EIA studies finalized at the scoping stage are covered by the proponent, then the project proponent may be asked to provide such information. If such information is declined by the project proponent or is unlikely to be provided early enough so as to complete the environmental appraisal within prescribed time of 60 days, the EAC/SEAC may recommend for rejection of the proposal with the same reason.
- Appraisal shall be strictly in terms of the ToR for EIA studies finalized at the scoping stage and the concerns expressed during public consultation.
- This process of appraisal shall be completed within 60 days from the receipt of the updated EIA report and EMP report, after completing public consultation.
- The EIA report will be typically examined for following:
 - Project site description supported by topographic maps & photographs – detailed description of topography, land use and activities at the proposed project site and its surroundings (buffer zone) supported by photographic evidence.
 - Clarity in description of drainage pattern, location of eco-sensitive areas, vegetation characteristics, wildlife status - highlighting significant environmental attributes such as feeding, breeding and nesting grounds of wildlife species, migratory corridor, wetland, erosion and neighboring issues.
 - Description of the project site – how well the interfaces between the projects related activities and the environment have been identified for the entire project cycle *i.e.*, construction, operation and decommissioning at the end of the project life.
 - How complete and authentic are the baseline data pertaining to flora and fauna and socio economic aspects?
 - Citing of proper references, with regard to the source(s) of baseline data as well as the name of the investigators/ investigating agency responsible for collecting the primary data.
 - How consistent are the various values of environmental parameters with respect to each other?
 - Is a reasonable assessment of the environmental and social impact made for the identified environmental issues including project affected people?
 - To what extent the proposed environmental plan will mitigate the environmental impact and at what estimated cost, shown separately for construction, operation and closure stages and also separately in terms of capital and recurring expenses along with details of agencies that will be responsible for the implementation of environmental plan/ conservation plan.

- How well the concerns expressed/highlighted during Public hearing have been addressed and incorporated in the EMP giving item wise financial provisions and commitments (in quantified terms)?
- How far the proposed environmental monitoring plan will effectively evaluate the performance of the EMP? Are details for environmental monitoring plan provided in the same manner as the EMP?
- Identification of hazard and quantification of risk assessment and whether appropriate mitigation plan has been included in the EMP?
- Does the proposal include a well formulated time bound green belt development plan for mitigating environmental problems such as fugitive emission of dust, gaseous pollutants, noise, odour, *etc*?
- Does EIA makes a serious attempt to guide the project proponent for minimizing the requirement of natural resources including land, water energy and other non renewable resources?
- How well has the EIA statement been organized and presented so that the issues, their impact and environmental management strategies emerge clearly from it and how well organized was the power point presentation made before the expert committee?
- Is the information presented in the EIA adequately and appropriately supported by maps, imageries and photographs highlighting site features and environmental attributes?

4.12 Decision Making

The Chairperson reads the sense of the Committee and finalizes the draft minutes of the meeting, which are circulated by the Secretary to all the expert members invited to the meeting. Based on the response from the members, the minutes are finalized and signed by the Chairperson. This process for finalization of the minutes should be so organized that the time prescribed for various stages is not exceeded.

Approval / Rejection / Reconsideration

- The Authority shall consider the recommendations of concerned appraisal Committee and convey its decision within 45 days of the receipt of recommendations.
- If the Authority disagrees with the recommendations of the Appraisal Committee, then reasons shall be communicated to concerned Appraisal Committee and applicant within in 45 days from the receipt of the recommendations. The Appraisal Committee concerned shall consider the observations of the Authority and furnish its views on the observations within further period of 60 days. The Authority shall take a decision within in the next 30 days based on the views of appraisal Committee.
- If the decision of the Authority is not conveyed within the time, then the proponent may proceed as if the prior environmental clearance sought has been granted or denied by the regulatory authority in terms of the final recommendation of the concerned appraisal Committee. For this purpose, the decision of the Appraisal Committee will be a public document, once the period specified above for taking the decision by the Authority is over.

- In case of the Category B projects, application shall be received by the Member–Secretary of the SEIAA and clearance shall also be issued by the same SEIAA.
- Deliberate concealment and/or submission of false or misleading information or data which is material to screening or scoping or appraisal or decision on the application shall make the application liable for rejection, and cancellation of prior environmental clearance granted on that basis. Rejection of an application or cancellation of a prior environmental clearance already granted, on such ground, shall be decided by the regulatory authority, after giving a personal hearing to the applicant, and following the principles of natural justice.

If approved

- The concerned MoEF/SEIAA will issue the environmental clearance for the project.
- The project proponent should make sure that the award of prior environmental clearance is properly publicized in at least two local newspapers of the district or state where the proposed project is located. For instance, the executive summary of the prior environmental clearance may be published in the newspaper along with the information about the location (website/office where it is displayed for public) where the detailed prior environmental clearance is made available. The MoEF and SEIAA/UTEIAA, as the case may be, shall also place the prior environmental clearance in the public domain on Government Portal. Further copies of the prior environmental clearance shall be endorsed to the Heads of local bodies, Panchayats and Municipal bodies in addition to the relevant offices of the Government.
- The prior environmental clearance will be valid from the start date to actual commencement of the production of the developmental activity.
- Usual validity period will be 5 years from the date of issuing environmental clearance, unless specified by EAC/SEAC.
- A prior environmental clearance issued to a project proponent can be transferred to another legal person entitled to undertake the project, upon application by the transferor to the concerned Authority or submission of no-objection of the transferor by the transferee to the concerned Authority for the concurrence. In this case, EAC/SEAC concurrence is not required, but approval from the concerned authority is required to avail the same project configurations, validity period transferred to the new legally entitled person to undertake the project.

4.13 Post-clearance Monitoring Protocol

The MoEF, Government of India will monitor and take appropriate action under the EP Act, 1986.

- In respect of Category A projects, it shall be mandatory for the project proponent to make public the environmental clearance granted for their project along with the environmental conditions and safeguards at their cost by advertising it at least in two local newspapers of the district or State where the project is located and in addition, this shall also be displayed in the project proponents website permanently.
- In respect of Category B projects, irrespective of its clearance by MoEF/SEIAA, the project proponent shall prominently advertise in the newspapers indicating that the project has been accorded environment clearance and the details of MoEF website where it is displayed.

- The MoEF and the SEIAA/UTEIAA, as the case may be, shall also place the environmental clearance in the public domain on Government Portal.
- Copies of the environmental clearance shall be submitted by the project proponents to the Heads of the local bodies, Panchayats and Municipal bodies in addition to the relevant offices of the Government who in turn have to display the same for 30 days from the date of receipt.

The project proponent must submit half-yearly compliance reports in respect of the stipulated prior environmental clearance terms and conditions in hard and soft copies to the regulatory authority concerned, on 1st June and 1st December of each calendar year.

All such compliance reports submitted by the project management shall be public documents. Copies of the same shall be given to any person on application to the concerned regulatory authority. Such latest such compliance report shall also be displayed on the website of the concerned regulatory Authority

The SPCB shall incorporate EIA clearance conditions into consent conditions in respect of Category A and Category B projects and in parallel monitor and enforce the same.

5.

STAKEHOLDERS' ROLES AND RESPONSIBILITIES

Prior environmental clearance process involves many stakeholders *i.e.*, Central Government, State Government, SEIAA, EAC at the National Level, SEAC, Public Agency, SPCB, the project proponent, and the public.

- Roles and responsibilities of the organizations involved in different stages of prior environmental clearance are listed in Table 5-1.
- Organization-specific functions are listed in Table 5-2.

In this Chapter, constitution, composition, functions, *etc.*, of the Authorities and the Committees are discussed in detail.

Table 5-1: Roles and Responsibilities of Stakeholders Involved in Prior Environmental Clearance

Stage	MoEF/SEIAA	EAC/SEAC	Project Proponent	EIA Consultant	SPCB/Public Agency	Public and Interest Group
Screening	Receives application and takes advice of EAC/SEAC	Advises the MoEF/SEIAA	Submits application (Form 1) and provides necessary information	Advises and assists the proponent by providing technical information		
Scoping	Approves the ToR, communicates the same to the project proponent and places the same in the website	Reviews the ToR, visits the proposed site, if required and recommends the ToR to the MoEF/SEIAA	Submits the draft ToR to SEIAA and facilitates the visit of the EAC/SEAC members to the project site	Prepares ToR		
EIA Report & Public Hearing	Reviews and forwards copies of the EIA report to SPCB/public agency for conducting public hearing Places the		Submits detailed EIA report as per the finalized ToR Facilitates the public hearing by arranging presentation on the project, EIA and EMP – takes note of objections and updates the	Prepares the EIA report Presents and appraises the likely impacts and pollution control measures proposed in the public hearing	Reviews EIA report and conducts public hearing in the manner prescribed Submits proceedings and views of SPCB, to	Participates in public hearings and offers comments and observations Comments can be sent directly to SEIAA through

Stakeholders' Roles and Responsibilities

Stage	MoEF/SEIAA	EAC/SEAC	Project Proponent	EIA Consultant	SPCB/ Public Agency	Public and Interest Group
	summary of EIA report in the website Conveys objections to the project proponent for update, if any		EMP accordingly		the Authority and the project proponent as well	Internet in response to the summary placed in the website
Appraisal and Clearance	Receives updated EIA Takes advice of EAC/SEAC, approves EIA and attaches the terms and conditions	Critically examines the reports, presentation of the proponent and appraises MoEF/SEIAA (recommendations are forwarded to MoEF/SEIAA)	Submits updated EIA, EMP reports to MoEF/SEIAA. Presents the overall EIA and EMP including public concerns to EAC/SEAC	Provides technical advise to the project proponent and if necessary presents the proposed measures for mitigation of likely impacts (terms and conditions of clearance)		
Post-clearance Monitoring			Implements environmental protection measures prescribed and submits periodic monitoring results	Conducts periodic monitoring	Incorporate s the clearance conditions into appropriate consent conditions and ensures implementation	

Table 5-2: Organization-specific Functions

Organization	Functions
Central Government	<ul style="list-style-type: none"> ▪ Constitutes the EAC ▪ Considering recommendations of the State Government, constitutes the SEIAA & SEAC ▪ Receives application from the project proponent in case of Category A projects or Category B projects attracting general condition ▪ Communicates the ToR finalized by the EAC to the project proponent. ▪ Receives EIA report from the project proponent and soft copy of summary of the report for placing in the website ▪ Summary of EIA report will be placed in website. Forwards the received responses to the project proponent

Stakeholders' Roles and Responsibilities

Organization	Functions
	<ul style="list-style-type: none"> ▪ Engages other public agency for conducting public hearings in cases where the SPCB does not respond within time ▪ Receives updated EIA report from project proponent incorporating the considerations from the proceedings of public hearing and responses received through other media ▪ Forwards updated EIA report to the EAC for appraisal ▪ Either accepts the recommendations of EAC or asks for reconsideration of specific issues for review by the EAC. ▪ Takes the final decision – acceptance/ rejection – of the project proposal and communicates the same to the project proponent
State Government	<ul style="list-style-type: none"> ▪ Identifies experts as per the composition specified in the Notification and subsequent guidelines to recommend to the the Central Government. ▪ Extends funding support to fulfill the functions of SEIAA/SEAC ▪ Engages other public agency for conducting public hearings in cases where the SPCB does not respond within time ▪ State Governments will suitably pay the public agency for conducting such activity
EAC	<ul style="list-style-type: none"> ▪ Reviews Form 1 and its attachments ▪ Visits site(s), if necessary ▪ Finalizes ToR and recommends to the Central Government, which in turn communicates the finalized ToR to the project proponent, if not exempted by the Notification ▪ Reviews EIA report, proceedings and appraises their views to the Central government ▪ If the Central Government has any specific views, then the EAC reviews again for appraisal
SEIAA	<ul style="list-style-type: none"> ▪ Receives application from the project proponent ▪ Considers SEAC's views for finalization of ToR ▪ Communicates the finalized ToR to the project proponent ▪ Receives EIA report from project proponent ▪ Uploads the summary of EIA report in the website in cases of Category B projects ▪ Forwards the responses received to the project proponent ▪ Receives updated EIA report from project proponent incorporating the considerations from the proceedings of public hearing and responses received through other media ▪ Forwards updated EIA report to SEAC for appraisal ▪ Either accepts the recommendations of SEAC or asks for reconsideration of specific issues for review by SEAC. ▪ Takes the final decision and communicates the same to the project proponent
SEAC	<ul style="list-style-type: none"> ▪ Reviews Form 1 ▪ If necessary visits, site(s) for finalizing the ToR ▪ Reviews updated EIA - EMP report and ▪ Appraises the SEIAA
SPCB	<ul style="list-style-type: none"> ▪ Receives request from project proponent and conducts public hearing in the manner prescribed. ▪ Conveys proceedings to concerned authority and project proponent
Public Agency	<ul style="list-style-type: none"> ▪ Receives request from the respective Governments to conduct public hearing ▪ Conducts public hearing in the manner prescribed. ▪ Conveys proceedings to the concerned Authority/EAC /Project proponent

5.1 SEIAA

- SEIAA is constituted by the MoEF to take final decision regarding the acceptance/rejection of prior environmental clearance to the project proposal for all Category 'B' projects.
- The state government may decide whether to house them at the Department of Environment or at any other Board for effective operational support.
- State Governments can decide whether the positions are permanent or part-time. The Central Government (MoEF) continues to follow the model of paying fee (TA/DA, accommodation and sitting fee) to the Chairperson and the members of EAC. As such, the State Government is to fund SEIAA & SEAC and decide the appropriate institutional support for them.

A. Constitution

- SEIAA is constituted by the Central Government comprising of three members including a Chairperson and Member–Secretary to be nominated by the State Government or UT Administration concerned.
- The Central Government will notify as and when the nominations (in order) are received from the State Governments, within 30 days from the date of receipt.
- The Chairperson and the non-official member shall have a fixed term of three years, from the date of Notification by the Central Government constituting the Authority.

The form used by the State Governments to submit nominations for Notification by the Central Government is provided in **Annexure X**.

B. Composition

- Chairperson shall be an expert in the EIA process
- Member–Secretary shall be a serving officer of the concerned State Government/ UT Administration familiar with the environmental laws.
- Member–Secretary may be of a level equivalent to the Director, Dept. of Environment or above – a full time member.
- All the members including the Chairperson shall be the experts as per the criteria set in the Notification.
- The Government servants can only serve as the Member–Secretary to SEIAA and the Secretary to SEAC. All other members including Chairperson of the SEIAA and SEAC shall not be comprised of serving Government Officers; industry representatives; and the activists.
- Serving faculty (academicians) is eligible for the membership in the Authority and/or the Committees, if they fulfill the criteria given in Appendix VI to the Notification.
- This is to clarify that the serving Government officers shall not be nominated as professional/expert member of SEIAA/SEAC/EAC.
- Professionals/Experts in the SEIAA and SEAC shall be different.

Summary regarding the eligibility criteria for Chairperson and Members of the SEIAA is given in Table 5-3.

C. Decision-making process

- The decision of the Authority shall be arrived through consensus.
- If there is no consensus, the Authority may either ask SEAC for reconsideration or may reject the approval.
- All decisions of the SEIAA shall be taken in a meeting and shall ordinarily be unanimous. In case a decision is taken by majority, details of views, for and against the decision, shall be clearly recorded in minutes of meeting and a copy thereof shall be sent to MoEF.

Table 5-3: SEIAA: Eligibility Criteria for Chairperson / Members / Secretary

S. No.	Attribute		Requirement		
			Members	Member–Secretary	Chairperson
1	Professional qualification as per the Notification		Compulsory	Compulsory	Compulsory
2	Experience (Fulfilling any one of a, b, c)	a	Professional Qualification + 15 years of experience in one of the expertise area mentioned in the Appendix VI	Professional Qualification + 15 years of experience in one of the expertise area mentioned in the Appendix VI	Professional Qualification + 15 years of experience in one of the expertise area mentioned in the Appendix VI
		b	Professional Qualification +PhD+10 years of experience in one of the expertise area mentioned in Appendix VI	Professional Qualification +PhD+10 years of experience in one of the expertise area mentioned in the Appendix VI	Professional Qualification +PhD+10 years of experience in one of the expertise area mentioned in the Appendix VI
		c	Professional Qualification +10 years of experience in one of the expertise area mentioned in the Appendix VI + 5 years interface with environmental issues, problems and their management	Professional Qualification +10 years of experience in one of the expertise area mentioned in the Appendix VI + 5 years interface with environmental issues, problems and their management	-----
3	Test of independence (conflict of interest) and minimum grade of the Secretary of the Authority		<p>Shall not be a serving government officer</p> <p>Shall not be a person engaged in industry and their associations</p> <p>Shall not be a person associated with environmental activism</p>	<p>Only serving officer from the State Government (DoE) familiar with environmental laws not below the level of Director</p>	<p>Shall not be a serving government officer</p> <p>Shall not be a person engaged in industry and their associations</p> <p>Shall not be a person associated with environmental activism</p>

Stakeholders' Roles and Responsibilities

S. No.	Attribute	Requirement		
		Members	Member–Secretary	Chairperson
4	Age	Below 67 years at the time of Notification of the Authority	As per State Government Service Rules	Below 72 Years at the time of the Notification of the Authority
5	Other memberships in Central/State Expert Appraisal Committee	Shall not be a member in any SEIAA/EAC/SEAC	Shall not be a member in any SEIAA/EAC/SEAC	Shall not be a member in any SEIAA/EAC/SEAC
6	Tenure of earlier appointment (continuous)	Only one term before this in continuity is permitted	Not applicable	Only one term before this in continuity is permitted
7	Eminent environmental expertise with understanding on environmental aspects and impacts	Desirable	Desirable	Compulsory
8	Expertise in the environmental clearance process	Desirable	Desirable	Compulsory

Notes:

- 1. A member after continuous membership in two terms (6 years) shall not be considered for further continuation. His/her nomination may be considered after a gap of one term (three years), if other criteria meet.*
- 2. Chairperson/Member once notified may not be removed prior to the tenure of three years without cause and proper enquiry.*

5.2 EAC and SEAC

EAC and SEAC are independent Committees to review each developmental activity and offer its recommendations for consideration of the Central Government and SEIAA respectively.

A. Constitution

- EAC and SEAC shall be constituted by the Central Government comprising a maximum of 15 members including a Chairperson and Secretary. In case of SEAC, the State Government or UT Administration is required to nominate the professionals/experts for consideration and Notification by the Central Government.
- The Central Government will notify as and when the nominations (in order) are received from the State Governments, within 30 days from the date of receipt.
- The Chairperson and the non-official member shall have a fixed term of three years, from the date of Notification by the Central Government.
- The Chairperson shall be an eminent environmental expert with understanding on environmental aspects and environmental impacts. The Secretary of the SEAC shall be a State Government officer, not below the level of a Director/Chief Engineer.

- The members of the SEAC need not be from the same State/UT.
- In case the State Governments/ Union Territories so desire, the MoEF can form regional EAC to serve the concerned States/Union Territories.
- State Governments may decide to their convenience to house SEAC at the Department of Environment or at SPCB or at any other department, to extend support to the SEAC activities.

B. Composition

- Composition of EAC/SEAC as per the Notification is given in **Annexure IX**.
- Secretary to EAC/SEAC may invite a maximum of two professionals/experts with the prior approval of the Chairperson, if desired, for taking the advisory inputs for appraisal. In such case, the invited experts will not take part in the decision making process.
- The Secretary of each EAC/SEAC preferably be an officer of the level equivalent to or above the level of Director, MoEF, GoI.

C. Decision making

The EAC and SEAC shall function on the principle of collective responsibility. The Chairperson shall endeavor to reach a consensus in each case, and if consensus cannot be reached, the view of the majority shall prevail.

D. Operational issues

- Secretary may deal with all correspondence, formulate agenda and prepare agenda notes. Chairperson and other members may act only for the meetings.
- Chairperson of EAC/SEAC shall be one among the expert members having considerable professional experience with proven credentials.
- EAC/SEAC shall meet at least once every month or more frequently, if so needed, to review project proposals and to offer recommendations for the consideration of the Authority.
- EAC/SEAC members may inspect the site at various stages *i.e.*, during screening, scoping and appraisal, as per the need felt and decided by the Chairperson of the Committee.
- The respective Governments through the Secretary of the Committee may pay/reimburse the participation expenses, honorarium *etc.*, to the Chairperson and members.

i. Tenure of EAC/SEIAA/SEAC

The tenure of Authority/Committee(s) shall be for a fixed period of three years. At the end of the three years period, the Authority and the committees need to be re-constituted. However, staggered appointment dates may be adopted to maintain continuity of members at a given point of time.

ii. Qualifying criteria for nomination of a member to EAC/SEIAA/SEAC

While recommending nominations and while notifying the members of the Authority and Expert Committees, it shall be ensured that all the members meet the following three criteria:

- Professional qualification
- Relevant experience/Experience interfacing with environmental management
- Absence of conflict of interest

These are elaborated subsequently.

a) Professional qualification

The person should have at least (i) 5 years of formal University training in the concerned discipline leading to a MA/MSc Degree, or (ii) in case of Engineering/Technology/Architecture disciplines, 4 years formal training in a professional training course together with prescribed practical training in the field leading to a B.Tech/B.E./B.Arch. Degree, or (iii) Other professional degree (e.g. Law) involving a total of 5 years of formal University training and prescribed practical training, or (iv) Prescribed apprenticeship/articeship and pass examinations conducted by the concerned professional association (e.g. MBA/IAS/IFS). In selecting the individual professionals, experience gained by them in their respective fields will be taken note of.

b) Relevant experience

- Experience shall be related to professional qualification acquired by the person and be related to one or more of the expertise mentioned for the expert members. Such experience should be a minimum of 15 years.
- When the experience mentioned in the foregoing sub-paragraph interfaces with environmental issues, problems and their management, the requirement for the length of the experience can be reduced to a minimum of 10 years.

c) Absence of conflict of interest

For the deliberations of the EAC/SEAC to be independent and unbiased, all possibilities of potential conflict of interests have to be eliminated. Therefore, serving government officers; persons engaged in industry and their associations; persons associated with the formulation of development projects requiring prior environmental clearance and persons associated with environmental activism shall not be considered for membership of SEIAA/ SEAC/ EAC.

iii. Age

Below 70 years for the members and below 72 years for the Chairperson of the SEIAA/SEAC/EAC. The applicability of the age is at the time of the Notification of the SEIAA/SEAC/EAC by the Central Government.

Summary regarding the eligibility criteria for Chairperson and Members of the EAC/SEAC is given in Table 5-4.

Table 5-4: EAC/SEAC: Eligibility Criteria for Chairperson / Members / Secretary

S. No.	Attribute		Requirement		
			Expert members	Secretary	Chairperson
1	Professional qualification as per the Notification		Compulsory	Compulsory	Compulsory
2	Experience (Fulfilling any one of a, b, c)	a	Professional Qualification + 15 years of experience in one of the expertise area mentioned in the Appendix VI	Professional Qualification + 15 years of experience in one of the expertise area mentioned in the Appendix VI	Professional Qualification + 15 years of experience in one of the expertise area mentioned in the Appendix VI
		b	Professional Qualification +PhD+10 years of experience in one of the expertise area mentioned in the Appendix VI	Professional Qualification +PhD+10 years of experience in one of the expertise area mentioned in the Appendix VI	Professional Qualification +PhD+10 years of experience in one of the expertise area mentioned in Appendix VI
		c	Professional Qualification +10 years of experience in one of the expertise area mentioned in the Appendix VI + 5 years interface with environmental issues, problems and their management	Professional Qualification +10 years of experience in one of the expertise area mentioned in the Appendix VI + 5 years interface with environmental issues, problems and their management	-----
3	Test of independence (conflict of interest) and minimum grade of the Secretary of the Committees		<p>Shall not be a serving government officer</p> <p>Shall not be a person engaged in industry and their associations</p> <p>Shall not be a person associated with environmental activism</p>	<p>In case of EAC, not less than a Director from the MoEF, Government of India</p> <p>In case of SEAC, not below the level of Director/Chief Engineer from the State Government (DoE)</p>	<p>Shall not be a serving government officer</p> <p>Shall not be a person engaged in industry and their associations</p> <p>Shall not be a person associated with environmental activism</p>
4	Age		Below 67 years at the time of Notification of the Committee	As per state Government Service Rules	Below 72 Years at the time of the Notification of the Committee
5	Membership in Central/State Expert Appraisal Committee		Only one other than this nomination is permitted	Shall not be a member in other SEIAA/EAC/SEAC	Shall not be a member in any other SEIAA/EAC/SEAC
6	Tenure of earlier appointment (continuous)		Only one term before this in continuity is permitted	Not applicable	Only one term before this in continuity is permitted

Stakeholders' Roles and Responsibilities

S. No.	Attribute	Requirement		
		Expert members	Secretary	Chairperson
7	Eminent environmental expertise with understanding on environmental aspects and impacts	Desirable	Not applicable	Compulsory

Notes:

1. A member after continuous membership in two terms (six years) shall not be considered for further continuation. His/her nomination may be reconsidered after a gap of one term (three years), if other criteria meet.

2. Chairperson/Member once notified may not be removed prior to the tenure of 3 years with out cause and proper enquiry. A member after continuous membership in two terms (6 years) shall not be considered for further continuation. The same profile may be considered for nomination after a gap of three years, i.e., one term, if other criteria are meeting.

E. Other conditions that may be considered

- An expert member of one State/UT, can have at the most another State/UT Committee membership, but in no case more than two Committees at a given point of time.
- An expert member of a Committee shall not have membership continuously in the same committee for more than two terms, i.e., six years. They can be nominated after a gap of three years, i.e., one term. When a member of Committee has been associated with any development project, which comes for prior environmental clearance, he/she may not participate in the deliberations and the decisions in respect to that particular project.
- At least four members shall be present in each meeting to fulfill the quorum
- If a member does not consecutively attend six meetings, without prior intimation to the Committee his/her membership may be terminated by the Notifying Authority. Prior information for absence due to academic pursuits, career development and national/state-endorsed programmes may be considered as genuine grounds for retention of membership.

ANNEXURE I
A Compilation of Legal Instruments

A Compilation of Legal Instruments

Sl. No.	Legal Instrument (Type, Reference, Year)	Responsible Ministries or Bodies	Chemical Use Categories/ Pollutants	Objective of Legislation	Relevant Articles/Provisions
1	Air (Prevention and Control of Pollution) Act, 1981 amended 1987	Central Pollution Control Board and State Pollution Control Boards	Air pollutants from chemical industries	The prevention, control and abatement of air pollution	Section 2: Definitions Section 21: Consent from State Boards Section 22: Not to allow emissions exceeding prescribed limits Section 24: Power of Entry and Inspection Section 25: Power to Obtain Information Section 26: Power to Take Samples Section 37-43: Penalties and Procedures
2	Air (Prevention and Control of Pollution) (Union Territories) Rules, 1983	Central Pollution Control Board and State Pollution Control Boards	Air pollutants from chemical industries	The prevention, control and abatement of air pollution	Rule 2: Definitions Rule 9: Consent Applications
3	Water (Prevention and Control of Pollution) Act, 1974 amended 1988	Central Pollution Control Board and State Pollution Control Boards	Water Pollutants from water polluting industries	The prevention and control of water pollution and also maintaining or restoring the wholesomeness of water	Section 2: Definitions Section 20: Power to Obtain Information Section 21: Power to Take Samples Section 23: Power of Entry and Inspection Section 24: Prohibition on Disposal Section 25: Restriction on New Outlet and New Discharge Section 26: Provision regarding existing discharge of sewage or trade effluent Section 27: Refusal or withdrawal of consent by state boards Section 41-49: Penalties and Procedures
4	Water (Prevention and Control of Pollution) Rules, 1975	Central Pollution Control Board and State Pollution Control Boards	Water Pollutants from water polluting industries	The prevention and control of water pollution and also maintaining or restoring the wholesomeness of water	Rule 2: Definitions Rule 30: Power to take samples Rule 32: Consent Applications
5	The Environment (Protection) Act, 1986,	Ministry of Environment and	All types of environmental pollutants	Protection and Improvement of the Environment	Section 2: Definitions Section 7: Not to allow emission or discharge of

	amended 1991	Forests, Central Pollution Control Board and State Pollution Control Boards			environmental pollutants in excess of prescribed standards Section 8: Handling of Hazardous Substances Section 10: Power of Entry and Inspection Section 11: Power to take samples Section 15-19: Penalties and Procedures
6	Environmental (Protection) Rules, 1986 (Amendments in 1999, 2001, 2002, 2002, 2002, 2003, 2004)	Ministry of Environment and Forests, Central Pollution Control Board and State Pollution Control Boards	All types of Environmental Pollutants	Protection and Improvement of the Environment	Rule 2: Definitions Rule 3: Standards for emission or discharge of environmental pollutants Rule 5: Prohibition and restriction on the location of industries and the carrying on process and operations in different areas Rule 13: Prohibition and restriction on the handling of hazardous substances in different areas Rule 14: Submission of environmental statement
7	Hazardous Waste (Management and Handling) Rules, 1989 amended 2000 and 2003	MoEF, CPCB, SPCB, DGFT, Port Authority and Customs Authority	Hazardous Wastes generated from industries using hazardous chemicals	Management & Handling of hazardous wastes in line with the Basel convention	Rule 2: Application Rule 3: Definitions Rule 4: Responsibility of the occupier and operator of a facility for handling of wastes Rule 4A: Duties of the occupier and operator of a facility Rule 4B: Duties of the authority Rule 5: Grant of authorization for handling hazardous wastes Rule 6: Power to suspend or cancel authorization Rule 7: Packaging, labeling and transport of hazardous wastes Rule 8: Disposal sites Rule 9: Record and returns Rule 10: Accident reporting and follow up Rule 11: Import and export of hazardous waste for dumping and disposal Rule 12: Import and export of hazardous waste for recycling and reuse

					<p>Rule 13: Import of hazardous wastes Rule 14: Export of hazardous waste Rule 15: Illegal traffic Rule 16: Liability of the occupier, transporter and operator of a facility Rule 19: Procedure for registration and renewal of registration of recyclers and re-refiners Rule 20: Responsibility of waste generator</p>
8	<p>Manufacture Storage and Import of Hazardous Chemicals Rules, 1989 amended 2000</p>	<p>Ministry of Environment & Forests, Chief Controller of Imports and Exports, CPCB, SPCB, Chief Inspector of Factories, Chief Inspector of Dock Safety, Chief Inspector of Mines, AERB, Chief Controller of Explosives, District Collector or District Emergency Authority, CEES under DRDO</p>	<p>Hazardous Chemicals - Toxic, Explosive, Flammable, Reactive</p>	<p>Regulate the manufacture, storage and import of Hazardous Chemicals</p>	<p>Rule 2: Definitions Rule 4: responsibility of the Occupier Rule 5: Notification of Major Accidents Rule 7-8: Approval and notification of site and updating Rule 10-11: Safety Reports and Safety Audit reports and updating Rule 13: Preparation of Onsite Emergency Plan Rule 14: Preparation of Offsite Emergency Plan Rule 15: Information to persons likely to get affected Rule 16: Proprietary Information Rule 17: Material Safety Data Sheets Rule 18: Import of Hazardous Chemicals</p>
9	<p>Chemical Accidents (Emergency Planning, Preparedness and Response) Rules, 1996</p>	<p>CCG, SCG, DCG, LCG and MAH Units</p>	<p>Hazardous Chemicals - Toxic, Explosive, Flammable, Reactive</p>	<p>Emergency Planning Preparedness and Response to chemical accidents</p>	<p>Rule 2: Definitions Rule 5: Functions of CCG Rule 7: Functions of SCG Rule 9: Functions of DCG Rule 10: Functions of LCG</p>
10	<p>EIA Notification, 2006</p>	<p>MoEF, SPCB</p>	<p>For all the identified developmental activities in the notification</p>	<p>Requirement of environmental clearance before establishment of or modernization / expansion of identified developmental projects.</p>	<p>Requirements and procedure for seeking environmental clearance of projects</p>

11	Factories Act, 1948	Ministry of Labour, DGFASLI and Directorate of Industrial Safety and Health/Factories Inspectorate	Chemicals as specified in the Table	Control of workplace environment, and providing for good health and safety of workers	<p>Section 2: Interpretation</p> <p>Section 6: Approval, licensing and registration of factories</p> <p>Section 7A: General duties of the occupier</p> <p>Section 7B: General duties of manufacturers etc., as regards articles and substances for use in factories</p> <p>Section 12: Disposal of wastes and effluents</p> <p>Section 14: Dust and fume</p> <p>Section 36: Precautions against dangerous fumes, gases, etc.</p> <p>Section 37: Explosion or inflammable dust, gas, etc.</p> <p>Chapter IVA: Provisions relating to Hazardous processes</p> <p>Section 87: Dangerous operations</p> <p>Section 87A: Power to prohibit employment on account of serious hazard</p> <p>Section 88: Notice of certain accident</p> <p>Section 88A: Notice of certain dangerous occurrences</p> <p>Chapter X: Penalties and procedures</p>
----	---------------------	---	--	--	--

ANNEXURE II
General Standards for Discharge of Environmental Pollutants as per
CPCB

Table: Water Quality Standards

S. No.	Parameter	Standards			
		Inland Surface Water	Public Sewer	Land for Irrigation	Marine Coastal Areas
1.	2.	3.			
		(a)	(b)	(c)	(d)
1.	Colour and odour	See Note-1	—	See Note-1	See Note-1
2.	Suspended Solids, mg/l, Max	100	600	200	(a) For process waste water-100 (b) For cooling water effluent-10 per cent above total suspended matter of influent cooling water.
3.	Particle size of suspended solids	Shall pass 850 micron IS Sieve	—	—	(a) Floatable solids, Max 3 mm (b) Settleable solids Max 850 microns.
4.	Dissolved solids (inorganic), mg/a, mac	2100	2100	2100	—
5.	pH value	5.5 to 9.0	5.5 to 9.0	5.5 to 9.0	5.5 to 9.0
6.	Temperature °C, Max	Shall not exceed 40 in any section of the stream within 15 meters down stream from the effluent outlet	45 at the point of discharge	—	45 at the point of discharge
7.	Oil and grease, mg/l, max	10	20	10	20
8.	Total residual chlorine, mg/l, Max.	1.0	—	—	1.0
9.	Ammonical nitrogen (as N), mg/l, Max.	50	50	—	50
10.	Total Kjeldahl nitrogen (as N), mg/l, Max.	100	—	—	100
11.	Free Ammonia (as NH ₃), mg/l, Max.	5.0	—	—	5.0
12.	Biochemical Oxygen Demand (5 days at 20°C) Max.	30	350	100	100
13.	Chemical Oxygen Demand, mg/l, Max.	250	—	—	250
14.	Arsenic (as As), mg/l, Max.	0.2	0.2	0.2	0.2
15.	Mercury (as Hg), mg/l, Max.	0.01	0.01	—	0.01
16.	Lead (as Pb), mg/l, Max.	0.1	1.0	—	1.0
17.	Cadmium (as Cd), mg/l, Max.	2.0	1.0	—	2.0

18.	Hexavalent chromium (as Cr+6) mg/l, Max.	0.1	2.0	—	1.0
19.	Total chromium as (Cr), mg/l, Max.	2.0	2.0	—	2.0
20.	Copper (as Cu), mg/l, Max.	3.0	3.0	—	3.0
21.	Zinc (as Zn), mg/l, Max.	5.0	15	—	15
22.	Selenium (as Se), mg/l, Max.	0.05	0.05	—	0.05
23.	Nickel (as Ni), mg/l, Max.	3.0	3.0	—	5.0
24.	Boron (as B), mg/l, Max.	2.0	2.0	2.0	—
25.	Percent Sodium, Max.	—	60	60	—
26.	Residual sodium carbonate, mg/l, Max.	—	—	5.0	—
27.	Cyanide (as CN), mg/l, Max.	0.2	2.0	0.2	0.2
28.	Chloride (as Cl), mg/l, Max.	1000	1000	600	(a)
29.	Fluoride (as F), mg/l, Max.	2.0	15	—	15
30.	Dissolved Phosphates (as P), mg/l, Max.	5.0	—	—	—
31.	Sulphate (as SO ₄), mg/l, Max.	1000	1000	1000	—
32.	Sulphide (as S), mg/l, Max.	2.0	—	—	5.0
33.	Pesticides	Absent	Absent	Absent	Absent
34.	Phenolic compounds (as C ₆ H ₅ OH), mg/l, Max.	1.0	5.0	—	5.0
35.	Radioactive materials				
	(a) Alpha emitters MC/ml, Max.	10 ⁻⁷	10 ⁻⁷	10 ⁻⁸	10 ⁻⁷
	(b) Beta emitters uc/ml, Max.	10 ⁻⁶	10 ⁻⁶	10 ⁻⁷	10 ⁻⁶

Note :-

1. All efforts should be made to remove colour and unpleasant odour as far as practicable.
2. The standards mentioned in this notification shall apply to all the effluents discharged such as industrial mining and mineral processing activities municipal sewage etc.

Table: Noise Standards

Ambient air quality standards in respect of noise

Area Code	Category of Area	Limits in dB (A) Leq	
		Day Time	Night Time
(A)	Industrial area	75	70
(B)	Commercial area	65	55
(C)	Residential area	55	45
(D)	Silence zone	50	40

Note :

1. Day time is reckoned in between 6.00 AM and 9.00 PM
2. Night time is reckoned in between 9.00 PM and 6.00 AM
3. Silence zone is defined as areas upto 100 meters around such premises as hospitals, educational institutions and courts. The Silence zones are to be declared by the Competent Authority.
4. Use of vehicular horns, loudspeakers and bursting of crackers shall be banned in these zones.
5. Mixed categories of areas should be declared as one of the four above mentioned categories by the Competent Authority and the corresponding standards shall apply.

Standards/Guidelines for Control of Noise Pollution from Stationary Diesel Generator (DG) Sets

(A) Noise Standards for DG Sets (15-500 KVA)

The total sound power level, L_w , of a DG set should be less than, $94+10 \log_{10} (KVA)$, dB (A), at the manufacturing stage, where, KVA is the nominal power rating of a DG set.

This level should fall by 5 dB (A) every five years, till 2007, i.e. in 2002 and then in 2007.

(B) Mandatory acoustic enclosure/acoustic treatment of room for stationary DG sets (5 KVA and above)

Noise from the DG set should be controlled by providing an acoustic enclosure or by treating the room acoustically.

The acoustic enclosure/acoustic treatment of the room should be designed for minimum 25 dB(A) Insertion Loss or for meeting the ambient noise standards, whichever is on the higher side (if the actual ambient noise is on the higher side, it may not be possible to check the performance of the acoustic enclosure/acoustic treatment. Under such circumstances the performance may be checked for noise reduction upto actual ambient noise level, preferably, in the night time). The measurement for Insertion Loss may be done at different points at 0.5m from the acoustic enclosure/room, and then averaged.

The DG set should also be provide with proper exhaust muffler with Insertion Loss of minimum 25 dB(A).

(C) Guidelines for the manufacturers/users of DG sets (5 KVA and above)

1. The manufacturer should offer to the user a standard acoustic enclosure of 25 dB(A) Insertion Loss and also a suitable exhaust muffler with Insertion Loss of 25 dB(A).

2. The user should make efforts to bring down the noise levels due to the DG set, outside his premises, within the ambient noise requirements by proper siting and control measures.
3. The manufacturer should furnish noise power levels of the unlicensed DG sets as per standards prescribed under (A)
4. The total sound power level of a DG set, at the user's end, shall be within 2 dB(A) of the total sound power level of the DG set, at the manufacturing stage, as prescribed under (A).
5. Installation of a DG set must be strictly in compliance with the recommendation of the DG set manufacturer.
6. A proper routine and preventive maintenance procedure for the DG set should be set and followed in consultation with the DG set manufacturer which would help prevent noise levels of the DG set from deteriorating with use.

Order of the Lt. Governor of Delhi in respect of D.G. Sets (5th December, 2001)

In exercise of the powers conferred by section 5 of the Environment (Protection) Act, 1986, (29 of 1986), read with the Government of India, Ministry of Home Affairs notification S.O. 667 (E) bearing No. F.No. U-11030/J/91-VTL dated 10th September, 1992, the Lt. Governor of Government of National Capital of Delhi hereby directs to all owners/users of generators sets in the National Capital Territory of Delhi as follows :-

1. that generator sets above the capacity of 5 KVA shall not be operated in residential areas between the hours of 10.00 PM to 6.00 AM;
2. that the generator sets above the capacity of 5 KVA in all areas residential/commercial/industrial shall operate only with the mandatory acoustic enclosures and other standards prescribed in the Environment (Protection) Rules, 1986;
3. that mobile generator sets used in social gatherings and public functions shall be permitted only if they have installed mandatory acoustic enclosures and adhere to the prescribed standards for noise and emission as laid down in the Environment (Protection) Rules, 1986.

The contravention of the above directions shall make the offender liable for prosecution under section 15 of the said Act which stipulates punishment of imprisonment for a term which may extend to five years with fine which may extend to one lakh rupees, or with both, and in case the failure of contravention continues, with additional fine which may extend to five thousand rupees for every day during which such failure or contravention continues after the conviction for the first such failure or contravention and if still the failure or contravention continues beyond a period of one year after the date of contravention, the offender continues beyond a period of one year after the date of contravention, the offender shall be punishable with imprisonment for a term which may extend to seven years.

Order Dated: 21st June, 2002

In exercise of the powers conferred by section 5 of the Environment (Protection) Act, 1986 (29 of 1986) read with the Govt. of India, Ministry of Home Affairs notification S.O. 667(E) bearing No. U-11030/J/91-VTL dated the 10th September, 1992, the Lt. Governor Govt. of the National Capital Territory of Delhi hereby makes the following amendment/modification in his order dated the 5th December, 2001 regarding the operation of generator sets, namely:-

Amendments/modifications

In the above said order, for clause(1), the following shall be substituted, namely:-

“(1) that the generator sets above 5KVA shall not be operated in residential areas between the hours from 10.00 p.m. to 6.00 a.m. except generator sets of Group Housing Societies and Multi-storey residential apartments”.

DIESEL GENERATOR SETS: STACK HEIGHT

The minimum height of stack to be provided with each generator set can be worked out using the following formula:

$$H = h + 0.2 \times \sqrt{\text{KVA}}$$

H = Total height of stack in metre

h = Height of the building in metres where the generator set is installed

KVA = Total generator capacity of the set in KVA

Based on the above formula the minimum stack height to be provided with different range of generator sets may be categorized as follows:

For Generator Sets	Total Height of stack in metre
50 KVA	Ht. of the building + 1.5 metre
50-100 KVA	Ht. of the building + 2.0 metre
100- 150 KVA	Ht. of the building + 2.5 metre
150-200 KVA	Ht. of the building + 3.0 metre
200-250 KVA	Ht. of the building + 3.5 metre
250-300 KVA	Ht. of the building + 3.5 metre

Similarly for higher KVA ratings a stack height can be worked out using the above formula

Source: Evolved By CPCB

[Emission Regulations Part IV: COINDS/26/1986-87]

ANNEXURE III
Form 1 (Application Form for Obtaining EIA Clearance)

FORM 1

(I) BASIC INFORMATION

S. No.	Item	Details
1.	Name of the project/s	
2.	S.No. in the schedule	
3.	Proposed capacity/area/length/tonnage to be handled/command area/lease area/number of wells to be drilled	
4.	New/Expansion/Modernization	
5.	Existing Capacity/Area etc.	
6.	Category of Project i.e., 'A' or 'B'	
7.	Does it attract the general condition? If yes, please specify.	
8.	Does it attract the specific condition? If yes, Please specify.	
9.	Location	
	Plot/Survey/Khasra No.	
	Village	
	Tehsil	
	District	
	State	
10.	Name of the applicant	
11.	Registered Address	
12.	Address for correspondence:	
	Name	
	Designation (Owner/Partner/CEO)	
	Address	
	Pin Code	
	E-mail	
	Telephone No.	
	Fax No.	
13.	Details of alternative Sites examined, if any location of these sites should be shown on a toposheet.	Village-District-State 1. 2. 3.

S. No.	Item	Details
14.	Interlined Projects	
15.	Whether separate application of interlined project has been submitted	
16.	If yes, date of submission	
17.	If no, reason	
18.	Whether the proposal involves approval/clearance under: The Forest (Conservation) Act, 1980 The Wildlife (Protection) Act, 1972 The C.R.Z. Notification, 1991	
19.	Forest land involved (hectares)	
20.	Whether there is any litigation pending against the project and/or land in which the project is propose to be set up Name of the Court Case No. Orders/directions of the Court, if any and its relevance with the proposed project.	

(II) ACTIVITY

1. Construction, operation or decommissioning of the Project involving actions, which will cause physical changes in the locality (topography, land use, changes in water bodies, etc.)

S.No.	Information/Checklist confirmation	Yes/No	Details thereof (with approximate quantities /rates, wherever possible) with source of information data
1.1	Permanent or temporary change in land use, land cover or topography including increase in intensity of land use (with respect to local land use plan)		
1.2	Clearance of existing land, vegetation and buildings?		
1.3	Creation of new land uses?		
1.4	Pre-construction investigations e.g. bore houses, soil testing?		
1.5	Construction works?		

S.No.	Information/Checklist confirmation	Yes/No	Details thereof (with approximate quantities /rates, wherever possible) with source of information data
1.6	Demolition works?		
1.7	Temporary sites used for construction works or housing of construction workers?		
1.8	Above ground buildings, structures or earthworks including linear structures, cut and fill or excavations		
1.9	Underground works including mining or tunneling?		
1.10	Reclamation works?		
1.11	Dredging?		
1.12	Offshore structures?		
1.13	Production and manufacturing processes?		
1.14	Facilities for storage of goods or materials?		
1.15	Facilities for treatment or disposal of solid waste or liquid effluents?		
1.16	Facilities for long term housing of operational workers?		
1.17	New road, rail or sea traffic during construction or operation?		
1.18	New road, rail, air waterborne or other transport infrastructure including new or altered routes and stations, ports, airports etc?		
1.19	Closure or diversion of existing transport routes or infrastructure leading to changes in traffic movements?		
1.20	New or diverted transmission lines or pipelines?		
1.21	Impoundment, damming, culverting, realignment or other changes to the hydrology of watercourses or aquifers?		
1.22	Stream crossings?		
1.23	Abstraction or transfers of water form ground or surface waters?		
1.24	Changes in water bodies or the land surface affecting drainage or run-off?		
1.25	Transport of personnel or materials for construction, operation or decommissioning?		

S.No.	Information/Checklist confirmation	Yes/No	Details thereof (with approximate quantities /rates, wherever possible) with source of information data
1.26	Long-term dismantling or decommissioning or restoration works?		
1.27	Ongoing activity during decommissioning which could have an impact on the environment?		
1.28	Influx of people to an area in either temporarily or permanently?		
1.29	Introduction of alien species?		
1.30	Loss of native species or genetic diversity?		
1.31	Any other actions?		

2. Use of Natural resources for construction or operation of the Project (such as land, water, materials or energy, especially any resources which are non-renewable or in short supply):

S.No.	Information/checklist confirmation	Yes/No	Details thereof (with approximate quantities /rates, wherever possible) with source of information data
2.1	Land especially undeveloped or agricultural land (ha)		
2.2	Water (expected source & competing users) unit: KLD		
2.3	Minerals (MT)		
2.4	Construction material – stone, aggregates, sand / soil (expected source – MT)		
2.5	Forests and timber (source – MT)		
2.6	Energy including electricity and fuels (source, competing users) Unit: fuel (MT), energy (MW)		
2.7	Any other natural resources (use appropriate standard units)		

3. Use, storage, transport, handling or production of substances or materials, which could be harmful to human health or the environment or raise concerns about actual or perceived risks to human health.

S.No	Information/Checklist confirmation	Yes/No	Details thereof (with approximate quantities/rates, wherever possible) with source of information data
3.1	Use of substances or materials, which are hazardous (as per MSIHC rules) to human health or the environment (flora, fauna, and water supplies)		
3.2	Changes in occurrence of disease or affect disease vectors (e.g. insect or water borne diseases)		
3.3	Affect the welfare of people e.g. by changing living conditions?		
3.4	Vulnerable groups of people who could be affected by the project e.g. hospital patients, children, the elderly etc.,		
3.5	Any other causes		

4. Production of solid wastes during construction or operation or decommissioning (MT/month)

S.No.	Information/Checklist confirmation	Yes/No	Details thereof (with approximate quantities/rates, wherever possible) with source of information data
4.1	Spoil, overburden or mine wastes		
4.2	Municipal waste (domestic and or commercial wastes)		
4.3	Hazardous wastes (as per Hazardous Waste Management Rules)		
4.4	Other industrial process wastes		
4.5	Surplus product		
4.6	Sewage sludge or other sludge from effluent treatment		
4.7	Construction or demolition wastes		
4.8	Redundant machinery or equipment		

S.No.	Information/Checklist confirmation	Yes/No	Details thereof (with approximate quantities/rates, wherever possible) with source of information data
4.9	Contaminated soils or other materials		
4.10	Agricultural wastes		
4.11	Other solid wastes		

5. Release of pollutants or any hazardous, toxic or noxious substances to air (kg/hr)

S.No	Information/Checklist confirmation	Yes/No	Details thereof (with approximate quantities/rates, wherever possible) with source of information data
5.1	Emissions from combustion of fossil fuels from stationary or mobile sources		
5.2	Emissions from production processes		
5.3	Emissions from materials handling including storage or transport		
5.4	Emissions from construction activities including plant and equipment		
5.5	Dust or odours from handling of materials including construction materials, sewage and waste		
5.6	Emissions from incineration of waste		
5.7	Emissions from burning of waste in open air (e.g. slash materials, construction debris)		
5.8	Emissions from any other sources		

6. Generation of Noise and Vibration, and Emissions of Light and Heat:

S.No.	Information/Checklist confirmation	Yes/No	Details thereof (with approximate quantities/rates, wherever possible) with source of information data with source of information data
6.1	From operation of equipment e.g. engines, ventilation plant, crushers		
6.2	From industrial or similar processes		
6.3	From construction or demolition		
6.4	From blasting or piling		
6.5	From construction or operational traffic		
6.6	From lighting or cooling systems		
6.7	From any other sources		

7. Risks of contamination of land or water from releases of pollutants into the ground or into sewers, surface waters, groundwater, coastal waters or the sea:

S.No.	Information/Checklist confirmation	Yes/No	Details thereof (with approximate quantities/rates, wherever possible) with source of information data
7.1	From handling, storage, use or spillage of hazardous materials		
7.2	From discharge of sewage or other effluents to water or the land (expected mode and place of discharge)		
7.3	By deposition of pollutants emitted to air into the land or into water		
7.4	From any other sources		
7.5	Is there a risk of long term build up of pollutants in the environment from these sources?		

8. Risk of accidents during construction or operation of the Project, which could affect human health or the environment

S.No	Information/Checklist confirmation	Yes/No	Details thereof (with approximate quantities/rates, wherever possible) with source of information data
8.1	From explosions, spillages, fires etc from storage, handling, use or production of hazardous substances		
8.2	From any other causes		
8.3	Could the project be affected by natural disasters causing environmental damage (e.g. floods, earthquakes, landslides, cloudburst etc)?		

9. Factors which should be considered (such as consequential development) which could lead to environmental effects or the potential for cumulative impacts with other existing or planned activities in the locality

S. No.	Information/Checklist confirmation	Yes/No	Details thereof (with approximate quantities/rates, wherever possible) with source of information data
9.1	Lead to development of supporting facilities, ancillary development or development stimulated by the project which could have impact on the environment e.g.: <ul style="list-style-type: none"> ▪ Supporting infrastructure (roads, power supply, waste or waste water treatment, etc.) ▪ housing development ▪ extractive industries ▪ supply industries ▪ other 		
9.2	Lead to after-use of the site, which could have an impact on the environment		
9.3	Set a precedent for later developments		
9.4	Have cumulative effects due to proximity to other existing or planned projects with similar effects		

(III) ENVIRONMENTAL SENSITIVITY

S.No.	Areas	Name/ Identity	Aerial distance (within 15 km.) Proposed project location boundary
1	Areas protected under international conventions, national or local legislation for their ecological, landscape, cultural or other related value		
2	Areas which are important or sensitive for ecological reasons - Wetlands, watercourses or other water bodies, coastal zone, biospheres, mountains, forests		
3	Areas used by protected, important or sensitive species of flora or fauna for breeding, nesting, foraging, resting, over wintering, migration		
4	Inland, coastal, marine or underground waters		
5	State, National boundaries		
6	Routes or facilities used by the public for access to recreation or other tourist, pilgrim areas		
7	Defence installations		
8	Densely populated or built-up area		
9	Areas occupied by sensitive man-made land uses (<i>hospitals, schools, places of worship, community facilities</i>)		
10	Areas containing important, high quality or scarce resources (<i>ground water resources, surface resources, forestry, agriculture, fisheries, tourism, minerals</i>)		
11	Areas already subjected to pollution or environmental damage. (<i>those where existing legal environmental standards are exceeded</i>)		
12	Areas susceptible to natural hazard which could cause the project to present environmental problems (<i>earthquakes, subsidence, landslides, erosion, flooding or extreme or adverse climatic conditions</i>)		

(IV) PROPOSED TERMS OF REFERENCE FOR EIA STUDIES

“I hereby given undertaking that the data and information given in the application and enclosure are true to the best of my knowledge and belief and I am aware that if any part of the data and information submitted is found to be false or misleading at any stage, the project will be rejected and clearance give, if any to the project will be revoked at our risk and cost.

Date: _____

Place: _____

Signature of the applicant
With Name and Full Address
(Project Proponent / Authorized Signatory)

NOTE:

1. The projects involving clearance under Coastal Regulation Zone Notification, 1991 shall submit with the application a C.R.Z. map duly demarcated by one of the authorized, agencies, showing the project activities, w.r.t. C.R.Z. and the recommendations of the State Coastal Zone Management Authority. Simultaneous action shall also be taken to obtain the requisite clearance under the provisions of the C.R.Z. Notification, 1991 for the activities to be located in the CRZ.
2. The projects to be located within 10km of the National Parks, Sanctuaries, Biosphere Reserves, Migratory Corridors of Wild Animals, the project proponent shall submit the map duly authenticated by Chief Wildlife Warden showing these features vis-à-vis the project location and the recommendations or comments of the Chief Wildlife Warden thereon.”

ANNEXURE IV
Critically Polluted Industrial Areas and Clusters/Potential Impact
Zones

**Table 1: Details of Critically Polluted Industrial Areas and Clusters / Potential Impact Zone
(Ref: Office Memorandum No. J-11013/5/2010-IA.II(I) Dated 13.1.2010)**

S. No.	Critically Polluted Industrial Area and CEPI	Industrial Clusters/ Potential Impact Zones
1.	Ankeshwar (Gujarat) CEPI-88.50(Ac_Wc_Lc)	<ul style="list-style-type: none"> ▪ GIDC Ankeshwar and GIDC, Panoli
2	Vapi (Gujarat) CEPI-88.09(Ac_Wc_Lc)	<ul style="list-style-type: none"> ▪ GIDC Vapi
3	Ghaziabad (Uttar Pradesh) CEPI-87.37(Ac_Wc_Lc)	<p>Sub-cluster A</p> <ul style="list-style-type: none"> ▪ Mohan nagar industrial area ▪ Rajinder nagar industrial area ▪ Sahibabad industrial area <p>Sub-cluster B</p> <ul style="list-style-type: none"> ▪ Pandav nagar industrial area ▪ Kavi nagar industrial area ▪ Bulandshahar road industrial area ▪ Amrit nagar ▪ Aryanagar industrial area <p>Sub-cluster C</p> <ul style="list-style-type: none"> ▪ Merrut road industrial are <p>Sub-cluster D</p> <ul style="list-style-type: none"> ▪ Loni industrial area ▪ Loni Road industrial area ▪ Roop nagar industrial area <p>Sub-cluster E</p> <ul style="list-style-type: none"> ▪ Hapur Road industrial area ▪ Dasna ▪ Philkura <p>Sub-cluster F (Other scattered industrial areas)</p> <ul style="list-style-type: none"> ▪ South side of GT road ▪ Kavi Nagar ▪ Tronica city ▪ Anand Nagar ▪ Jindal Nagar ▪ Prakash Nagar ▪ Rural industrial estate
4	Chandrapur (Maharashtra) CEPI-83.88 (Ac_Wc_Lc)	<ul style="list-style-type: none"> ▪ Chandrapur (MIDC Chandrapur, Tadali, Ghuggus, Ballapur)
5	Kobra (Chhatisgarh) CEPI-83.00 (Ac_Ws_Lc)	<ul style="list-style-type: none"> ▪ Industrial areas and their townships of NTPC, BALCO, CSEB (East) & CSEB (West) ▪ Korba town
6	Bhiwadi (Rajasthan) CEPI-82.91 (Ac_Wc_Ls)	<ul style="list-style-type: none"> ▪ RIICO industrial areas Phase I to IV ▪ Bhiwadi town ▪ Other surrounding industrial areas: Chopanki, Rampura Mundana, Khuskhera Phase I to III
7	Angul Talcer(Orissa) CEPI-82.09 (Ac_Wc_Lc)	<ul style="list-style-type: none"> ▪ MCL Coal mining area, Augul – Talcer region ▪ Industrial area (60 km x 45 km) <p>Following blocks of Augul district:</p> <ul style="list-style-type: none"> ▪ Kohina block ▪ Talcher block

		<ul style="list-style-type: none"> ▪ Angul block ▪ Chhendipada block ▪ Banarpal block ▪ Odapada block of Dhenkamal district
8	Vellore (North Arcot) (Tamil Nadu) CEPI-81.79 (Ac_Wc_Lc)	<ul style="list-style-type: none"> ▪ Ranipet, SIPCOT industrial complex
9	Singrauli (Uttar Pradesh) CEPI-81.73 (Ac_Wc_Ls)	<p>Sonebhadra (UP)</p> <ul style="list-style-type: none"> ▪ Dala-Tola ▪ Obra ▪ Renukoot ▪ Anpara ▪ Renusagar ▪ Kakri ▪ Dudhichuwa ▪ Bina ▪ Khadia ▪ Shakti nagar ▪ Rihand nagar ▪ Bijpur <p>Sigrauli (Madhya Pradesh)</p> <p>Vindhyachal nagar and Jaynat, Nigahi, Dudhichua, Amlohri & Jhingurdah townships</p>
10	Ludhiana (Punjab) CEPI-81.66 (Ac_Wc_Ls)	<p>Ludhiana municipal limits covering industrial clusters:</p> <ul style="list-style-type: none"> ▪ Focal point along with NH-I- Total eight phase ▪ Industrial area-B- from sherpur chowk to Gill road & Gill road to Miller Kotla road (left side of road) ▪ Mixed industrial area – right side of Gill road ▪ Industrial area –C (near Juglana village) ▪ Industrial area A & extension: area between old GT road and Ludhiana bypass road ▪ Industrial estate: near Dholwal chowk ▪ Mixes industrial area (MIA) Miller gunj ▪ MIA – bypass road ▪ Bahdur industrial area ▪ Tejpur industrial complex
11	Nazafgarh drain basin, Delhi CEPI-79.54 (As_Wc_Lc)	<ul style="list-style-type: none"> ▪ Industrial areas: Anand Parvat, Naraina, Okhla and Wazirpur
12	Noida (Uttar Pradesh) CEPI-78.90 (Ac_Wc_Lc)	<p>Territorial Jurisdiction of:</p> <ul style="list-style-type: none"> ▪ Noida Phase-1 ▪ Noida Phase-2 ▪ Noida Phase-3 ▪ Surajpur industrial area ▪ Greater Noida industrial area ▪ Village- Chhaparaula
13	Dhanbad (Jharkhand) CEPI-78.63 (Ac_Ws_Lc)	<p>Four blocks of Dhanbad district:</p> <ul style="list-style-type: none"> ▪ Sadar (Dhanbad Municipality) ▪ Jharia (Jharia Municipality, Sindri industrial area) ▪ Govindpur (Govindpur industrial estate) ▪ Nirsa
14	Dombivalli (Maharashtra) CEPI-78.41 (Ac_Wc_Ls)	<ul style="list-style-type: none"> ▪ MIDC Phase- I, Phase- II

15	Kanpur (Uttar Pradesh) CEPI-78.09 (Ac_Wc_Ls)	Industrial areas: <ul style="list-style-type: none"> ▪ Dada nagar ▪ Panki ▪ Fazalganj ▪ Vijay nagar ▪ Jajmau
16	Cuddalore (Tamil Nadu) CEPI-77.45 (As_Wc_Lc)	<ul style="list-style-type: none"> ▪ SIPCOT industrial complex, Phase I & II
17	Aurangabad (Maharashtra) CEPI-77.44 (Ac_Wc_Ls)	<ul style="list-style-type: none"> ▪ MIDC Chikhalthana, MIDC Waluj, MIDC Shendra, and Paithan road industrial area
18	Faridabad (Haryana) CEPI-77.07 (Ac_Ws_Lc)	<ul style="list-style-type: none"> ▪ Sector 27-A, B, C, D ▪ DLF phase- 1, sector 31,32 ▪ DLF phase- 2, sector 35 ▪ Sector 4, 6, 24, 27, 31, 59 ▪ Industrial area Hatin ▪ Industrial model township
19	Agra (Uttar Pradesh) CEPI-76.48 (As_Wc_Ls)	<ul style="list-style-type: none"> ▪ Nunihai industrial estate, Rambag nagar, UPSIDC industrial area, and Runukata industrial area
20	Manali (Tamil Nadu) CEPI-76.32 (Ac_Ws_Ls)	<ul style="list-style-type: none"> ▪ Manali industrial area
21	Haldia (West Bengal) CEPI-75.43 (As_Wc_Ls)	<ul style="list-style-type: none"> ▪ 5 km wide strip (17.4 x 5.0 km) of industrial area on the southern side of the confluence point of Rivers Hugli and Rupnarayan, covering ▪ Haldia municipal area & Sutahata block – I and II
22	Ahmedabad (Gujarat) CEPI-75.28 (Ac_Ws_Ls)	<ul style="list-style-type: none"> ▪ GIDC Odhav ▪ GIDC Naroda
23	Jodhpur (Rajasthan) CEPI-75.19 (As_Wc_Ls)	<ul style="list-style-type: none"> ▪ Industrial areas including Basni areas (phase-I & II), industrial estate, light & heavy industrial areas, industrial areas behind new power house, Mandore, Bornada, Sangariya and village Tanwada & Salawas. ▪ Jodhpur city
24	Greater Cochin (Kerala) CEPI-75.08 (As_Wc_Ls)	<ul style="list-style-type: none"> ▪ Eloor-Edayar industrial belt, ▪ Ambala Mogal industrial areas
25	Mandi Gobind Garh (Punjab) CEPI-75.08 (Ac_Ws_Lc)	<ul style="list-style-type: none"> ▪ Mandi Govindgarh municipal limit and khanna area
26	Howrah (West Bengal) CEPI-74.84 (As_Ws_Lc)	<ul style="list-style-type: none"> ▪ Liluah-Bamangachhi region, Howrah ▪ Jalan industrial complex-1, Howrah
27	Vatva (Gujarat) CEPI-74.77 (Ac_Wc_Ls)	<ul style="list-style-type: none"> ▪ GIDC Vatva, Narol industrial area (Villages Piplaj, Shahwadi, Narol)
28	Ib Valley (Orissa) CEPI-74.00 (Ac_Ws_Ls)	<ul style="list-style-type: none"> ▪ Ib Valley of Jharsuguda (Industrial and mining area)
29	Varansi-Mirzapur (Uttar Pradesh) CEPI-73.79 (As_Wc_Ls)	<ul style="list-style-type: none"> ▪ Industrial estate, Mirzapur ▪ Chunar ▪ Industrial estate, Chandpur, Varansi ▪ UPSIC, industrial estate, Phoolpur ▪ Industrial area, Ramnagar, Chandauli
30	Navi Mumbai (Maharashtra) CEPI-73.77 (Ac_Ws_Ls)	<ul style="list-style-type: none"> ▪ TTC industrial area, MIDC, Navi Mumbai (including Bocks-D, C, EL, A, R, General, Kalva)

31	Pali (Rajasthan) CEPI-73.73 (As_Wc_Ls)	<ul style="list-style-type: none"> ▪ Existing industrial areas: Mandia road, Puniyata road, Sumerpur ▪ Pali town
32	Mangalore (Karnataka) CEPI-73.68 (Ac_Ws_Ls)	<ul style="list-style-type: none"> ▪ Baikampady industrial area
33	Jharsuguda (Orissa) CEPI-73.34 (Ac_Ws_Ls)	<ul style="list-style-type: none"> ▪ Ib valley of Jharsuguda (Industrial and mining area)
34	Coimbatore (Tamil Nadu) CEPI-72.38 (Ac_Ws_Ln)	<ul style="list-style-type: none"> ▪ SIDCO, Kurichi industrial Clusters
35	Bhadravati (Karnataka) CEPI-72.33 (Ac_Ws_Ln)	<ul style="list-style-type: none"> ▪ KSSIDC Industrial area, Mysore paper mill & VISL township complex
36	Tarapur (Maharashtra) CEPI-72.01 (Ac_Ws_Ls)	<ul style="list-style-type: none"> ▪ MIDC Tarapur
37	Panipat (Haryana) CEPI-71.91 (As_Ws_Ls)	<ul style="list-style-type: none"> ▪ Panipat municipal limit and its industrial clusters
38	Indore (Madhya Pradesh) CEPI-71.26 (As_Ws_Ls)	<p>Following 09 industrial area:</p> <ul style="list-style-type: none"> ▪ Sanwer road ▪ Shivaji nagar ▪ Pologround ▪ Laxmibai nagar ▪ Scheme no.71 ▪ Navlakha ▪ Pipliya ▪ Palda ▪ Rau <p>Indore city</p> <p>Other surrounding industrial areas: Manglia, Rajoda, Asrawad, Tejpur Gadwadi</p>
39	Bhavnagar (Gujarat) CEPI-70.99 (As_Ws_Ls)	<ul style="list-style-type: none"> ▪ GIDI Chitra, Bhavnagar
40	Vishakhapatnam (Andhra Pradesh) CEPI-70.82 (As_Ws_Ls)	<ul style="list-style-type: none"> ▪ Bowl area (the area between Yarada hill range in the south to Simhachalam hill range in the north and sea on the east and the present NH-5 in the west direction)
41	Junagarh (Gujarat) CEPI-70.82 (As_Ws_Ls)	<p>Industrial areas:</p> <ul style="list-style-type: none"> ▪ Sabalpur ▪ Jay Bhavani ▪ Jay Bhuvneshwari ▪ GIDC Junagarh (I&II)
42	Asansole (West Bengal) CEPI-70.20 (As_Ws_Ls)	<ul style="list-style-type: none"> ▪ Bumpur area surrounding IISCO
43	Patancheru - Bollaram (Andhra Pradesh) CEPI-70.07 (As_Ws_Ls)	<p>Industrial area:</p> <ul style="list-style-type: none"> ▪ Patancheru ▪ Bollaram

Note:

Names of identified industrial clusters/potential impact zones are approximate location based on rapid survey and assessment and may alter partially subject to the detailed field study and monitoring. Detailed mapping will be made available showing spatial boundaries of the identified industrial clusters including zone of influence/ buffer zone, after in depth field study.

ANNEXURE V
Pre-Feasibility Report: Points for Possible Coverage

Table 1: Points for Possible Coverage in Pre-feasibility Report

S. No.	Contents	Points of Coverage in Pre-feasibility Report
I.	Executive summary	<ul style="list-style-type: none"> ▪ A miniature report of entire pre feasibility report.
II.	Project Details	
	Need/Justification of the Project	<ul style="list-style-type: none"> ▪ Current demand scenario of the product (chlorine, caustic soda, <i>etc.</i>) ▪ Alternatives to meet the demand of the product ▪ Post project scenario on residual demand, <i>etc.</i>
	Capacity of Chlor-alkali Industry	<ul style="list-style-type: none"> ▪ Production capacity of the industry ▪ Sustainability of raw material supply and quality ▪ Optimization of plant capacity, <i>etc.</i>
	Features of the project	<ul style="list-style-type: none"> ▪ Analysis of available/advanced technologies (membrane/diaphragm, <i>etc.</i>) ▪ Analysis of possible configurations for each technology or a combination of these technologies ▪ Process flow diagrams for each alternative technology ▪ Equipments used in the project and balance of the plant equipment ▪ General plant layout ▪ Construction details <ul style="list-style-type: none"> - Estimated duration - Number of construction workers including migrating workers - Construction equipment - Vehicular traffic - Source, mode of transportation and storage of construction material ▪ Traffic that would arise during different phases of the project and transportation mechanism to handle such traffic ▪ New facilities needed ▪ Product storage and associated transportation system ▪ Product demand & supply position data on regional basis, <i>etc.</i>
	Resources/raw materials	<ul style="list-style-type: none"> ▪ Details on raw material, byproducts/co-products – sodium chloride, potassium chloride, cooling agents, <i>etc.</i> ▪ Water requirement for process, utilities, domestic purposes, <i>etc.</i> ▪ Manpower ▪ Infrastructure ▪ Electrical power ▪ Construction materials like sand, brick, stone chips, borrow earth, metals, <i>etc.</i>
	Rejects (Pollution potential)	<ul style="list-style-type: none"> ▪ Air emissions – chlorine gas, hydrogen gas, <i>etc.</i> ▪ Water pollution – wastewater, <i>etc.</i> ▪ Solid / hazardous waste – contaminated sludge, <i>etc.</i> ▪ Noise ▪ Odour, <i>etc.</i>
	Project schedule	<ul style="list-style-type: none"> ▪ Project implementation schedule
	Future prospects	<ul style="list-style-type: none"> ▪ Ascertain the costs and benefits of the proposed project for project life ▪ Technical and logistic constraints/requirements of project sustainability, <i>etc.</i>
III.	Selection of site based on least possible impacts	

i.	Choice of site selection	
	Major techno-economic feasibility considerations	<ul style="list-style-type: none"> ▪ Land availability & its development ▪ Product demand around the selected site ▪ Access to site for transportation of equipments/ construction machinery, materials, <i>etc.</i> ▪ Raw material availability and its transportation ▪ Water availability and consumptive use ▪ Product transportation ▪ Infrastructure availability at selected site ▪ Inter-state issue, if any, <i>etc.</i>
	Incompatible landuse and ecologically sensitive attributes with respect to identified suitable sites	<ul style="list-style-type: none"> ▪ If any incompatible land-use attributes fall within the study area, the following details has to be provided: <ul style="list-style-type: none"> - Public water supply areas from rivers/surface water bodies, from groundwater - Scenic areas/tourism areas/hill resorts - Religious places, pilgrim centers that attract over 10 lakh pilgrims a year - Protected tribal settlements (notified tribal areas where industrial activity is not permitted); CRZ - Monuments of national significance, World Heritage Sites - Cyclone, Tsunami prone areas (based on last 25 years); - Airport areas - Any other feature as specified by the State or local government and other features as locally applicable, including prime agricultural lands, pastures, migratory corridors, <i>etc.</i> ▪ If ecologically sensitive attributes fall within the study area, please give details. Ecologically sensitive attributes include <ul style="list-style-type: none"> - National parks - Wild life sanctuaries Game reserve - Tiger reserve/elephant reserve/turtle nesting ground - Mangrove area - Wetlands - Reserved and protected forests - Endangered species of flora and fauna - Any other closed/protected area under the Wild Life (Protection) Act, 1972 - Any other eco – sensitive areas <i>etc.</i>
	Social aspects	<ul style="list-style-type: none"> ▪ Corporate social responsibilities ▪ Employments and infrastructure added in the vicinity of the plant ▪ Status of land availability, current and post project land use variation ▪ Social sensitivity and likely project affected people, <i>etc.</i>
ii.	Details of selected site	
	Land details	<ul style="list-style-type: none"> ▪ Land requirement and availability ▪ Land ownership details such as Government, private, tribal, non-tribal, <i>etc.</i> ▪ Total area of the project/site ▪ Prevailing land cost details, <i>etc.</i>
	Location	<ul style="list-style-type: none"> ▪ Geographical details - Longitude & latitude, village, taluka, district, state ▪ Approach to site – roads, railways and airports

		<ul style="list-style-type: none"> ▪ Distance from nearest residential and industrial areas ▪ Distance from nearest water bodies such as river, canal, dam, etc ▪ Distance from ecologically sensitive areas ▪ In case of flood prone areas, HFL of the site ▪ In case of seismic areas, seismic zone, active faults, occurrence on earthquakes, etc. ▪ Proximity from infrastructural facilities, <i>etc.</i>
	Physical characteristics	<ul style="list-style-type: none"> ▪ Demography ▪ Meteorological data ▪ Landuse pattern such as agricultural, barren, forest, <i>etc.</i> and details thereof ▪ Topography of the area ▪ Drainage patterns ▪ Soil condition and soil investigation results ▪ Ground profile and levels, <i>etc.</i>
IV.	Anticipated impacts based on project operations on receiving environment	<ul style="list-style-type: none"> ▪ Population ▪ Flora and fauna ▪ Water ▪ Soil ▪ Air ▪ Climate ▪ Landscape, <i>etc.</i>
V.	Proposed broad mitigation measures which could effectively be internalized as project components to have environmental and social acceptance of the proposed site	<ul style="list-style-type: none"> ▪ Preventive measures ▪ Source control measures ▪ Mitigation measures at the receiving environment, <i>etc.</i>
VI.	An indication of any difficulties (technical deficiencies or lack of know-how) encountered by the developer in compiling the required information.	

The above listing is not exhaustive. Thus the proponent may provide additional necessary information, felt appropriate, to include in the pre-feasibility study report in support of selecting the site for the proposed developmental activities. The Concerned EAC/SEAC during scrutiny, may specifically ask for any additional information/data required to substantiate the requirement to prescribe the ToR for EIA studies. However, it is to make clear that all the required further information by EAC/SEAC may be mentioned in one single letter, within the prescribed time.

ANNEXURE VI
Types of Monitoring and Network Design Considerations

TYPES OF MONITORING AND NETWORK DESIGN CONSIDERATIONS

A. Types of Monitoring

Monitoring refers to the collection of data using a series of repetitive measurements of environmental parameters (or, more generally, to a process of systematic observation). The environmental quality monitoring programme design will be dependent upon the monitoring objectives specified for the selected area of interest. The main types of EIA monitoring activities are:

- Baseline monitoring is the measurement of environmental parameters during the pre-project period for the purpose of determining the range of variation of the system and establishing reference points against which changes can be measured. This leads to the assessment of the possible (additional available) assimilative capacity of the environmental components in pre-project period w.r.t. the standard or target level.
- Effects monitoring is the measurement of environmental parameters during project construction and implementation to detect changes which are attributable to the project to provide the necessary information to:
 - verify the accuracy of EIA predictions; and
 - determine the effectiveness of measures to mitigate adverse effects of projects on the environment.
 - Feedback from environmental effect monitoring programs may be used to improve the predictive capability of EIAs and also determine whether more or less stringent mitigation measures are needed
- Compliance monitoring is the periodic sampling or continuous measurement of environmental parameters to ensure that regulatory requirements and standards are being met.

Compliance and effects monitoring occurs during the project construction, operation, and abandonment stages. The resources and institutional set-up should be available for the monitoring at these stages. All large-scale construction projects will require some construction stage monitoring. To control the environmental hazards of construction as specified in the EIA, a monitoring program should be established to ensure that each mitigation measure is effectively implemented. There are numerous potential areas for monitoring during operations.

The scope of monitoring topics discussed in this chapter is limited to Baseline and Effects monitoring. In addition, this chapter will also discuss the Compliance monitoring during the construction phase. Post-project monitoring requirements are discussed in the EMP.

Before any field monitoring tasks are undertaken there are many institutional, scientific, and fiscal issues that must be addressed in the implementation of an environmental monitoring program. Careful consideration of these issues in the design and planning stages will help avoid many of the pitfalls associated with environmental monitoring programs. Although these issues are important but the discussions here are confined to the monitoring network design component.

B. Network Design

Analysis of Significant Environmental Issues

At the outset of planning for an environmental monitoring network, the EIA manager may not know exactly what should be monitored, when monitoring should begin, where it should monitor, which techniques should be employed, and who should take responsibility for its conduct. Because there are usually a number of objective decisions associated with network design to be made, it is important to start with an analysis of environmental issues. The scoping phase of an EIA is designed to identify and focus on the major issues. Scoping should provide a valuable source of information on the concerns that need to be addressed by the monitoring network design. These are project specific as well as specific to the environmental setting of the location where the project is proposed to be located

Hence, the network designs are associated with questions like:

- What are the expected outputs of the monitoring activity?
- Which problems do we need to address to? *etc.*

Defining the output will influence the design of the network and optimize the resources used for monitoring. It will also ensure that the network is specially designed to optimize the information on the problems at hand

What to Monitor?

The question of what to monitor is associated with the identification of VECs.

VECs are generally defined as environmental attributes or components of the environment that are valued by society as identified during the scoping stage of the project. They are determined on the basis of perceived public concerns. For example, changes to water quality and quantity could have implications on fish by affecting habitat, food supply, oxygen, and contaminant uptake. Similarly, employment and business, and economies are both VECs that serve as pathways.

The choice of VECs is also related to the perceived significant impact of the project implementation on important environmental components. In general, the significance or importance of environmental components is judged based on:

- legal protection provided (for example, rare and endangered species)
- political or public concerns (for example, resource use conflicts and sustainable development)
- scientific judgment (for example, ecological importance); or
- commercial or economic importance

However, in addition to their economic, social, political or ecological significance, the chosen VEC should also have unambiguous operational ease, be accessible to prediction and measurement; and be susceptible to hazard. Once the VECs are defined, the VECs may be directly measured (for example, extent of habitat for an endangered species). In cases where it is impossible or impractical to directly measure the VECs, the chosen measurement endpoints or environmental indicators must correspond to, or be predictive of assessment endpoints.

The chosen environmental indicators must be: 1) measurable; 2) appropriate to the scale of disturbance/ contamination; 3) appropriate to the impact mechanism; 4) appropriate

and proportional to temporal dynamics; 5) diagnostic; and 6) standardized; as well as have: 1) a low natural variability; 2) a broad applicability; and 3) an existing data series.

Where, How and How Many Times to Monitor?

These are the other components of Monitoring Network Design. These questions are best answered based on local field conditions, capacity and resources available, prevailing legal and regulatory priorities, *etc.* For this screening or reconnaissance Surveys of the study area also necessary. This may also include some simple inexpensive measurements and assimilative/dispersion modeling. The data will give some information on the prevailing special and temporal variations, and the general background air pollution in the area. The number of monitoring stations and the indicators to be measured at each station in the final permanent network may then be decided upon based on the results of the screening study as well as on the knowledge of the sources of the proposed development and prevailing local environmental/meteorological conditions. The best possible definition of the air pollution problem, together with the analysis of the resources: personnel, budget and equipment available, represent the basis for the decision on the following questions:

- What spatial density (number) of sampling stations is required? How many samples are needed and during what period (sampling (averaging) time and frequency)?
- Where should the stations be located?
- What kind of equipment should be used?
- What additional background information is needed?
 - meteorology
 - topography
 - population density
 - emission sources and emission rates
 - effects and impacts
- How will the data be made available/communicated?

C. Site Selection

This normally means that for designing a monitoring programme in an (study) area which might have an impact, several monitoring stations are needed for characterizing the baseline conditions of the impacted area. When considering the location of individual samplers, it is essential that the data collected are representative for the location and type of area without the undue influence from the immediate surroundings. In any measurement point in the study area the total ambient concentration is the representative of:

- natural background concentration
- regional background
- impact of existing large regional sources such as Industrial emissions and other power plants

To obtain the information about the importance of these different contributions it is therefore necessary to locate monitoring stations so that they are representative for different impacts. In addition to the ambient pollution data, one would often need other data governing the variations such as meteorological data for air pollution, to identify and quantify the sources contributing to the measurements.. When considering the location of individual samplers, it is essential that the data collected are representative for the location and type of area without undue influence from the immediate surroundings.

ANNEXURE VII
Guidance for Assessment of Baseline Components and Attributes

GUIDANCE FOR ASSESSMENT OF BASELINE COMPONENTS AND ATTRIBUTES*

Attributes	Sampling		Measurement Method	Remarks
	Network	Frequency		
A. Air				
Meteorological <ul style="list-style-type: none"> ▪ Wind speed ▪ Wind direction ▪ Dry bulb temperature ▪ Wet bulb temperature ▪ Relative humidity ▪ Rainfall ▪ Solar radiation ▪ Cloud cover 	<ul style="list-style-type: none"> ▪ Minimum 1 site in the project impact area requirements ▪ Other additional site(s) are require depending upon the model applied or site sensitivities 	<ul style="list-style-type: none"> ▪ Min: 1 hrly observations from continuous records 	<ul style="list-style-type: none"> ▪ Mechanical / automatic weather station ▪ Rain gauge ▪ As per IMD ▪ As per IMD 	<ul style="list-style-type: none"> ▪ IS 5182 Part 1-20 Sit-specific primary data is essential ▪ Secondary data from IMD, New Delhi for the nearest IMD station
Pollutants <ul style="list-style-type: none"> ▪ SPM ▪ PM10, PM2.5 ▪ SO₂ ▪ NO₂ ▪ CO ▪ H₂S* ▪ NH₃* ▪ HC* ▪ Fluoride* ▪ Pb* ▪ VOC-PAH* ▪ Ozone ▪ Benzene ▪ Benzo(a)pyrene (Particulate phase only) ▪ Arsenic ▪ Nickel (parameters to be proposed by the proponent, in draft ToR, which will be reviewed and approved by	<ul style="list-style-type: none"> ▪ 10 to 15 locations in the project impact area 	<ul style="list-style-type: none"> ▪ 24 hrly twice a week ▪ 8 hrly twice a week ▪ 24 hrly twice a week 	<ul style="list-style-type: none"> ▪ Gravimetric (High – Volume) ▪ Gravimetric (High – Volume with Cyclone) ▪ EPA Modified West & Gaeke method ▪ Arsenite Modified Jacob & Hochheiser ▪ NDIR technique ▪ Methylene-blue ▪ Nessler’s Method ▪ Infra Red analyzer ▪ Specific Ion meter ▪ TOEM ▪ Beta attenuation ▪ UV photometric ▪ Chemiluminescence ▪ Chemical method ▪ Gas chromatography based continuos analyzer ▪ Adsorption and desorption followed by GC analysis 	<ul style="list-style-type: none"> ▪ Monitoring Network ▪ Minimum 2 locations in upwind side, more sites in downwind side / impact zone ▪ All the sensitive receptors need to be covered ▪ Measurement Methods ▪ As per CPCB standards for NAQM, 1994

Attributes	Sampling		Measurement Method	Remarks
	Network	Frequency		
EAC/SEAC)			<ul style="list-style-type: none"> ▪ Solvent extraction followed by HPLC/GC analysis ▪ AAS/ICP method after sampling on EPM 2000 or equivalent filter paper 	
B. Noise				
Hourly equivalent noise levels	<ul style="list-style-type: none"> ▪ Same as for Air Pollution along with others Identified in study area 	<ul style="list-style-type: none"> ▪ At least one day continuous in each season on a working and non-working day 	<ul style="list-style-type: none"> ▪ Instrument : Sensitive Noise level meter (preferably recording type) 	<ul style="list-style-type: none"> ▪ Min: IS: 4954- 1968 as adopted by CPCB
Hourly equivalent noise levels	<ul style="list-style-type: none"> ▪ Inplant (1.5 m from machinery or high emission processes) 	<ul style="list-style-type: none"> ▪ Same as above for day and night 	<ul style="list-style-type: none"> ▪ Instrument : Noise level metre 	<ul style="list-style-type: none"> ▪ CPCB / OSHA
Hourly equivalent noise levels	<ul style="list-style-type: none"> ▪ Highways (within 500 metres from the road edge) 	<ul style="list-style-type: none"> ▪ Same as above for day and night 	<ul style="list-style-type: none"> ▪ Instrument : Noise level meter 	<ul style="list-style-type: none"> ▪ CPCB / IS : 4954-1968
Peak particle velocity	<ul style="list-style-type: none"> ▪ 150- 200m from blast site 	<ul style="list-style-type: none"> ▪ Based on hourly observations 	<ul style="list-style-type: none"> ▪ PPV meter 	<ul style="list-style-type: none"> ▪
C. Water				
Parameters for water quality <ul style="list-style-type: none"> ▪ Ph, temp, turbidity, magnesium hardness, total alkalinity, chloride, sulphate, nitrate, fluoride, sodium, potassium salinity ▪ Total nitrogen, total phosphorus, DO, BOD, COD, Phenol ▪ Heavy metals ▪ Total coliforms, faecal coliforms ▪ Phyto plankton ▪ Zooplankton 	<ul style="list-style-type: none"> ▪ Set of grab samples during pre and post-monsoon for ground and surface water for the whole study zone. For lab analysis the samples should be preserved for transport safe 	<ul style="list-style-type: none"> ▪ Diurnal and season-wise 	<ul style="list-style-type: none"> ▪ Samples for water quality should be collected and analyzed as per: ▪ IS: 2488 (Part 1-5) methods for sampling and testing of industrial effluents ▪ Standard methods for examination of water and waste water analysis published by American Public Health Association. ▪ International standard practices for benthos and 	

Attributes	Sampling		Measurement Method	Remarks
	Network	Frequency		
<ul style="list-style-type: none"> ▪ Fish & other aquatic flora & fauna (parameters are given in ToR for EIA studies based on nature of project, raw material & process technology, location-nature/activities within of air basin)			aquatic flora & fauna	
For Surface Water Bodies				
<ul style="list-style-type: none"> ▪ Total Carbon ▪ PH ▪ Dissolved Oxygen ▪ Biological Oxygen Demand ▪ Free NH₄ ▪ Boron ▪ Sodium Absorption ratio ▪ Electrical Conductivity 	<ul style="list-style-type: none"> ▪ Monitoring locations should include up-stream, on site, down stream of proposed discharge point. Besides sampling should cover width of the river in case water quality modeling is proposed. ▪ Standard methodology for collection of surface water (BIS standards) ▪ At least one grab sample per location per season 	<ul style="list-style-type: none"> ▪ Yield & impact on water sources to be measured during critical season ▪ River Stretch within project area be divided in grids (say 1 km length and 1/3 width) and samples should be from each grid at a time when the wastewater discharged by other sources of pollution is expected to be maximum 	<ul style="list-style-type: none"> ▪ Samples for water quality should be collected and analyzed as per: ▪ IS: 2488 (Part 1-5) methods for sampling and testing of industrial effluents ▪ Standard methods for examination of water and wastewater analysis published by American Public Health Association. 	<ul style="list-style-type: none"> ▪ Historical data should be collected from relevant offices such as central water commission, state and central ground water board, Irrigation dept.
Parameters for wastewater characterization				
<ul style="list-style-type: none"> ▪ Temp, colour, odour, turbidity, TSS, TDS ▪ PH , alkalinity as CaCO₃, p value, M value, total hardness as CaCO₃, chloride as cl, sulphate as S04, Nitrate as NO₃, Floride as F, Phosphate as P04, Chromium as Cr (Hexavalent, total) Ammonical Nitrogen as N, TKN, % sodium, BOD at 20 C, COD, 	<ul style="list-style-type: none"> ▪ Implant Source depending upon the different waste streams the parameters can be optimized ▪ Grab and composite sampling representing avg of different process operations as well as worst emission scenario should be represented 	<ul style="list-style-type: none"> ▪ Different operational cycles as well as raw material variations should be reflected in the analysis 	<ul style="list-style-type: none"> ▪ Samples for water quality should be collected and analyzed as per: ▪ IS: 2488 (Part 1-5) methods for sampling and testing of industrial effluents ▪ Standard methods for examination of water and wastewater analysis published by American 	All plant sources categorized as: <ul style="list-style-type: none"> ▪ Different Process waste streams as well as run-off conditions ▪ ETP wastewater ▪ Domestic/ sanitary wastewater

Attributes	Sampling		Measurement Method	Remarks
	Network	Frequency		
DO, total residual chlorine as Cl ₂ , oil and grease, sulphide, phenolic compound			Public Health Association.	
D. Land Environment				
<ul style="list-style-type: none"> ▪ Soil ▪ Particle size distribution ▪ Texture ▪ pH ▪ Electrical conductivity ▪ Cation exchange capacity ▪ Alkali metals ▪ Sodium Absorption Ratio (SAR) ▪ Permeability ▪ Porosity 	<ul style="list-style-type: none"> ▪ One surface sample from each landfill and/or hazardous waste site (if applicable) and prime villages, (soil samples be collected as per BIS specifications) in the study area 	<ul style="list-style-type: none"> ▪ Season-wise 	<ul style="list-style-type: none"> ▪ Collected and analyzed as per soil analysis reference book, M.I.Jackson and soil analysis reference book by C.A. Black 	<ul style="list-style-type: none"> ▪ The purpose of impact assessment on soil (land environment) is to assess the significant impacts due to leaching of wastes or accidental releases and contaminating
Landuse / Landscape				
<ul style="list-style-type: none"> ▪ Location code ▪ Total project area ▪ Topography ▪ Drainage (natural) ▪ Cultivated, forest plantations, water bodies, roads and settlements 	<ul style="list-style-type: none"> ▪ At least 20 points along with plant boundary and general major land use categories in the study area. 	<ul style="list-style-type: none"> ▪ Drainage once in the study period and land use categories from secondary data (local maps) and satellite imageries 	<ul style="list-style-type: none"> ▪ Global positioning system ▪ Topo-sheets ▪ Satellite Imageries (1:25,000) 	<ul style="list-style-type: none"> ▪ Drainage within the plant area and surrounding is very important for storm water impacts. ▪ From land use maps sensitive receptors (forests, parks, mangroves etc.) can be identified

Attributes	Sampling		Measurement Method	Remarks
	Network	Frequency		
E. Solid Waste				
Quantity: <ul style="list-style-type: none"> ▪ Based on waste generated from per unit production ▪ Per capita contribution ▪ Collection, transport and disposal system ▪ Process Waste ▪ Quality (oily, chemical, biological) 	<ul style="list-style-type: none"> ▪ For green field unites it is based on secondary data base of earlier plants. 	<ul style="list-style-type: none"> ▪ Process wise or activity wise for respective raw material used. Domestic waste depends upon the season also 	Guidelines <ul style="list-style-type: none"> ▪ IS 9569 : 1980 ▪ IS 10447 : 1983 ▪ IS 12625 : 1989 ▪ IS 12647 : 1989 ▪ IS 12662 (PTI) 1989 	
Quality: <ul style="list-style-type: none"> ▪ General segregation into biological/organic/inert/hazardous ▪ Loss on heating ▪ pH ▪ Electrical Conductivity ▪ Calorific value, metals etc. 	<ul style="list-style-type: none"> ▪ Grab and Composite samples 	<ul style="list-style-type: none"> ▪ Process wise or activity wise for respective raw material used. Domestic waste depends upon the season also 	Analysis <ul style="list-style-type: none"> ▪ IS 9334 : 1979 ▪ IS 9235 : 1979 ▪ IS 10158 : 1982 	
Hazardous Waste				
<ul style="list-style-type: none"> ▪ Permeability And porosity ▪ Moisture pH ▪ Electrical conductivity ▪ Loss on ignition ▪ Phosphorous ▪ Total nitrogen ▪ Caution exchange capacity ▪ Particle size distribution ▪ Heavy metal ▪ Ansonia ▪ Fluoride 	<ul style="list-style-type: none"> ▪ Grab and Composite samples. Recyclable components have to analyzed for the recycling requirements 	<ul style="list-style-type: none"> ▪ Process wise or activity wise for respective raw material used. 	Analysis <ul style="list-style-type: none"> ▪ IS 9334 : 1979 ▪ IS 9235 : 1979 ▪ IS 10158 : 1982 	<ul style="list-style-type: none"> ▪ Impacts of hazardous waste should be performed critically depending on the waste characteristics and place of discharge. For land disposal the guidelines should be followed and impacts of accidental releases should be assessed
F. Biological Environment Aquatic				
<ul style="list-style-type: none"> ▪ Primary productivity ▪ Aquatic weeds 	<ul style="list-style-type: none"> ▪ Considering probable impact, sampling points 	<ul style="list-style-type: none"> ▪ Season changes are very important 	<ul style="list-style-type: none"> ▪ Standards techniques (APHA et. Al. 1995, Rau 	<ul style="list-style-type: none"> ▪ Seasonal sampling for aquatic biota

Attributes	Sampling		Measurement Method	Remarks
	Network	Frequency		
<ul style="list-style-type: none"> ▪ Enumeration of ▪ phytoplankton, zooplankton and benthos ▪ Fisheries ▪ Diversity indices ▪ Trophic levels ▪ Rare and endangered species ▪ Sanctuaries / closed areas / Coastal regulation zone (CRZ) ▪ Terrestrial ▪ Vegetation – species, list, economic importance, forest produce, medicinal value ▪ Importance value index (IVI) of trees ▪ Wild animals 	<p>and number of samples to be decided on established guidelines on ecological studies based on site eco-environment setting within 10/25 km radius from the proposed site</p> <ul style="list-style-type: none"> ▪ Samples to collect from upstream and downstream of discharge point, nearby tributaries at down stream, and also from dug wells close to activity site 		<p>and Wooten 1980) to be followed for sampling and measurement</p>	<ul style="list-style-type: none"> ▪ One season for terrestrial biota, in addition to vegetation studies during monsoon season ▪ Preliminary assessment ▪ Microscopic analysis of plankton and meiobenthos, studies of macrofauna, aquatic vegetation and application of indices, viz. Shannon, similarity, dominance IVI etc ▪ Point quarter plot-less method (random sampling) for terrestrial vegetation survey.
<p>Avifauna</p> <ul style="list-style-type: none"> ▪ Rare and endangered species ▪ Sanctuaries / National park / Biosphere reserve 	<ul style="list-style-type: none"> ▪ For forest studies, chronic as well as short-term impacts should be analyzed warranting data on micro climate conditions 			<ul style="list-style-type: none"> ▪ Secondary data to collect from Government offices, NGOs, published literature ▪ Plankton net ▪ Sediment dredge ▪ Depth sampler ▪ Microscope ▪ Field binocular
G. Socio Economic				
<ul style="list-style-type: none"> ▪ Demographic structure ▪ Infrastructure resource base ▪ Economic resource base ▪ Health status: Morbidity pattern ▪ Cultural and aesthetic attributes 	<ul style="list-style-type: none"> ▪ Socio-economic survey is based on proportionate, stratified and random sampling method 	<ul style="list-style-type: none"> ▪ Different impacts occurs during construction and operational phases of the project 	<ul style="list-style-type: none"> ▪ Primary data collection through R&R surveys (if require) or community survey are based on personal interviews and questionnaire 	<ul style="list-style-type: none"> ▪ Secondary data from census records, statistical hard books, toposheets, health records and relevant official records available with Govt. agencies

* Project Specific concerned parameters needs to be identified by the project proponent and shall be incorporated in the draft ToR, to be submitted to the Authority for the consideration and approval by the EAC/SEAC.

ANNEXURE VIII
Sources of Secondary Data

Annexure VIIIA: Potential Sources of Data For EIA

Information	Source
Air Environment	
1. Meteorology- Temperature, Rainfall, Humidity, Inversion, Seasonal Wind rose pattern (16 point compass scale), cloud cover, wind speed, wind direction, stability, mixing depth	<ul style="list-style-type: none"> ⊗ Indian Meteorology Department, Pune
2. Ambient Air Quality- 24 hourly concentration of SPM, RPM, SO ₂ , NO _x , CO	<ul style="list-style-type: none"> ⊗ Central Pollution Control Board (CPCB), ⊗ State Pollution Control Board (SPCB), ⊗ Municipal Corporations ⊗ Ministry of Environment and Forests (MoEF) ⊗ State Department of Environment (DoEN)
Water Environment	
3. Surface water- water sources, water flow (lean season), water quality, water usage, Downstream water users Command area development plan Catchment treatment plan	<ul style="list-style-type: none"> ⊗ Central Water Commission (CWC), ⊗ Central Pollution Control Board (CPCB), ⊗ State Pollution Control Board (SPCB), Central Water and Power Research Institute (CWPRS), Pune ⊗ State Irrigation Department ⊗ Hydel Power generation organizations such as NHPC, State SEBs
4. Ground Water- groundwater recharge rate/withdrawal rate, ground water potential groundwater levels (pre monsoon, post monsoon), ground water quality, changes observed in quality and quantity of ground water in last 15 years	<ul style="list-style-type: none"> ⊗ Central Ground Water Board (CGWB) ⊗ Central Ground Water Authority (CGWA) ⊗ State Ground Water Board (SGWB) ⊗ National Water Development Authority (NWDA)
5. Coastal waters- water quality, tide and current data, bathymetry	<ul style="list-style-type: none"> ⊗ Department of Ocean Development, New Delhi ⊗ State Maritime Boards ⊗ Naval Hydrographer's Office, Dehradun ⊗ Port Authorities ⊗ National Institute of Oceanography (NIO), Goa
Biological Environment	
6. Description of Biological Environment- inventory of flora and fauna in 7 km radius, endemic species, endangered species, Aquatic Fauna, Forest land, forest type and density of vegetation, biosphere, national parks, wild life sanctuaries, tiger reserve, elephant reserve, turtle nesting ground, core zone of biosphere reserve, habitat of migratory birds, routes of migratory birds	<ul style="list-style-type: none"> ⊗ District Gazetteers ⊗ National Remote Sensing Agency (NRSA), Hyderabad ⊗ Forest Survey of India, Dehradun ⊗ Wildlife Institute of India ⊗ World Wildlife Fund ⊗ Zoological Survey of India ⊗ Botanical Survey of India ⊗ Bombay Natural History Society, (BNHS), Mumbai ⊗ State Forest Departments ⊗ State Fisheries Department ⊗ Ministry of Environment and Forests ⊗ State Agriculture Departments ⊗ State Agriculture Universities
Land Environment	
7. Geographical Information-Latitude, Longitude, Elevation (above MSL)	<ul style="list-style-type: none"> ⊗ Toposheets of Survey of India, Pune ⊗ National Remote Sensing Agency (NRSA), Hyderabad ⊗ Space Application Centre (SAC), Ahmedabad

Information	Source
8. Nature of Terrain, topography map indicating contours (1:2500 scale)	<ul style="list-style-type: none"> ⑨ Survey of India Toposheets ⑨ National Remote Sensing Agency (NRSA), Hyderabad ⑨ State Remote Sensing Centre, ⑨ Space Application Centre (SAC), Ahmedabad
9. Hydrogeology- Hydrogeological report (in case of ground water is used/area is drought prone/wastewater is likely to discharged on land) Geomorphological analysis (topography and drainage pattern) Geological analysis (Geological Formations/Disturbances- geological and structural maps, geomorphological contour maps, structural features, including lineaments, fractures, faults and joints) Hydrogeological analysis (disposition of permeable formations, surface-ground water links, hydraulic parameter determination etc) Analysis of the natural soil and water to assess pollutant absorption capacity	<ul style="list-style-type: none"> ⑨ NRSA, Hyderabad ⑨ Survey of India Toposheets ⑨ Geological Survey of India ⑨ State Geology Departments ⑨ State Irrigation Department ⑨ Department of Wasteland Development, Ministry of Rural Areas ⑨ National Water Development Authority (NWDA)
10. Nature of Soil, permeability, erodibility classification of the land	<ul style="list-style-type: none"> ⑨ Agriculture Universities ⑨ State Agriculture Department ⑨ Indian Council for Agriculture Research ⑨ State Soil Conservation Departments ⑨ National Bureau of Soil Survey and Landuse Planning ⑨ Central Arid Zone Research Institute (CAZRI), Jodhpur
11. Landuse in the project area and 10 km radius of the periphery of the project	<ul style="list-style-type: none"> ⑨ Survey of India- Toposheets ⑨ All India Soil and Landuse Survey; Delhi ⑨ National Remote Sensing Agency (NRSA), Hyderabad ⑨ Town and County Planning Organisation ⑨ State Urban Planning Department ⑨ Regional Planning Authorities (existing and proposed plans) ⑨ Village Revenue Map- District Collectorate ⑨ Directorate of Economics and Statistics-State Government ⑨ Space Application Centre, Ahmedabad
12. Coastal Regulation Zones- CRZMP, CRZ classification, Demarcation of HTL and LTL*	<ul style="list-style-type: none"> ⑨ Urban Development Department ⑨ State Department of Environment ⑨ State Pollution Control Board ⑨ Space Application Centre* ⑨ Centre for Earth Sciences Studies, Thiruvanthapuram* ⑨ Institute of Remote Sensing, Anna University Chennai* ⑨ Naval Hydrographer's Office, Dehradun* ⑨ National Institute of Oceanography, Goa* ⑨ National Institute of Ocean Technology, Chennai ⑨ Centre for Earth Science Studies

* Agencies authorized for approval of demarcation of HTL and LTL

Information	Source
Social	
13. Socioeconomic - population, number of houses and present occupation pattern within 7 km from the periphery of the project	<ul style="list-style-type: none"> ⊗ Census Department ⊗ District Gazetteers- State Government ⊗ District Statistics- District Collectorate ⊗ International Institute of Population Sciences, Mumbai (limited data) ⊗ Central Statistical Organisation
14. Monuments and heritage sites	<ul style="list-style-type: none"> District Gazetteer Archeological Survey of India, INTACH District Collectorate Central and State Tourism Department State Tribal and Social Welfare Department
Natural Disasters	
15. Seismic data (Mining Projects)- zone no, no of earthquakes and scale, impacts on life, property existing mines	<ul style="list-style-type: none"> ⊗ Indian Meteorology Department, Pune ⊗ Geological Survey of India
16. Landslide prone zone, geomorphological conditions, degree of susceptibility to mass movement, major landslide history (frequency of occurrence/decade), area affected, population affected	<ul style="list-style-type: none"> ⊗ Space Application Centre
17. Flood/cyclone/droughts- frequency of occurrence per decade, area affected, population affected	<ul style="list-style-type: none"> ⊗ Natural Disaster Management Division in Department of Agriculture and Cooperation ⊗ Indian Meteorological Department
Industrial	
18. Industrial Estates/Clusters, Growth Centres	<ul style="list-style-type: none"> ⊗ State Industrial Corporation ⊗ Industrial Associations ⊗ State Pollution Control Boards ⊗ Confederation Indian Industries (CII) ⊗ FICCI
19. Physical and Chemical properties of raw material and chemicals (Industrial projects); fuel quality	<ul style="list-style-type: none"> ⊗ Material and Safety Data Sheets ⊗ ENVIS database of Industrial Toxicological Research Centre, Lucknow ⊗ Indian Institute Petroleum
20. Occupational Health and Industrial Hygiene-major occupational health and safety hazards, health and safety requirements, accident histories	<ul style="list-style-type: none"> ⊗ Central Labour Institute, Mumbai ⊗ Directorate of Industrial Safety ⊗ ENVIS Database of Industrial Toxicological Research Centre, Lucknow ⊗ National Institute of Occupational Health, Ahmedabad
21. Pollutant release inventories (Existing pollution sources in area within 10 km radius)	<ul style="list-style-type: none"> ⊗ Project proponents which have received EC and have commenced operations
22. Water requirement (process, cooling water, DM water, Dust suppression, drinking, green belt, fire service)	<ul style="list-style-type: none"> ⊗ EIA Reports ⊗ National and International Benchmarks

Annexure VIIIB: Summary of Available Data with Potential Data Sources for EIA

Agency	Information Available
1. Archaeological Survey of India Department of Culture Government of India Janpath, New Delhi - 110011 Asi@del3.vsnl.net.in	<ul style="list-style-type: none"> ⊙ Inventory of monuments and sites of national importance- Listing and documentation of monuments according to world heritage, pre historic, proto historic and secular, religious places and forts
2. Botanical Survey Of India P-8, Brabourne Road Calcutta 700001 Tel#033 2424922 Fax#033 2429330 Email: envis@cal2.vsnl.net.in . RO - Coimbatore, Pune, Jodhpur, Dehradun, Allahabad, Gantok, Itanagar, Port Blair	<ul style="list-style-type: none"> ⊙ Photodiversity documentation of flora at National, State and District level and flora of protected areas, hotspots, fragile ecosystems, sacred groves etc ⊙ Identification of threatened species including endemics, their mapping, population studies ⊙ Database related to medicinal plants, rare and threatened plant species ⊙ Red data book of Indian plants (Vol 1,2, and 3) ⊙ Manual for roadside and avenue plantation in India
3. Bureau of Indian Standards Manak Bhawan, 9 Bahadur Shah Zafar Marg, New Delhi 110 002 Tel#3230131, 3233375, 3239402 (10 lines) Fax : 91 11 3234062, 3239399, 3239382 Email- bis@vsnl.com	<ul style="list-style-type: none"> ⊙ Bureau of Indian Standards Committees on Earthquake Engineering and Wind Engineering have a Seismic Zoning Map and the Wind Velocity Map including cyclonic winds for the country
4. Central Water Commission (CWC) Sewa Bhawan, R.K.Puram New Delhi - 110066 cmanoff@niccwc.delhi.nic.in RO- Bangalore, Bhopal, Bhubaneshwar, Chandigarh, Coimbatore/Chennai, Delhi, Hyderabad, Lucknow, Nagpur, Patna, Shillong, Siliguri and Vadodara	<ul style="list-style-type: none"> ⊙ Central Data Bank -Collection, collation and Publishing of Hydrological, Hydrometeorological, Sediment and Water Quality data- ⊙ Basin wise Master Plans ⊙ Flood atlas for India ⊙ Flood Management and Development and Operation of Flood Forecasting System- CWC operate a network of forecasting stations Over 6000 forecasts are issued every year with about 95% of the forecasts within the permissible limit. ⊙ Water Year Books, Sediment Year Books and Water Quality Year Books. ⊙ Also actively involved in monitoring of 84 identified projects through National, State and Project level Environmental Committees for ensuring implementation of environmental safeguards
5. Central Ground Water Board (HO) N.H.IV, New CGO Complex, Faridabad - 121001 RO - Guwahati, Chandigarh, Ahemadabad, Trivandrum, Calcutta, Bhopal, Lucknow, Banglore, Nagpur, Jammu, Bhubneshwar, Raipur, Jaipur, Chennai, Hyderabad, Patna	<ul style="list-style-type: none"> ⊙ surveys, exploration, monitoring of ground water development

¹⁶ Based on web search and literature review

6.	Central Pollution Control Board Parivesh Bhawan, CBD-cum-Office Complex East Arjun Nagar, DELHI - 110 032 INDIA E-mail : cpcb@alpha.nic.in	<ul style="list-style-type: none"> ⊗ National Air Quality Monitoring Programme ⊗ National River Water Quality Monitoring Programme- Global Environment Monitoring , MINARS ⊗ Zoning Atlas Programme ⊗ Information on 17 polluting category industries (inventory, category wise distribution, compliance, implementation of pollution control programmes)
7.	Central Arid Zone Research Institute, Jodhpur Email : cazri@x400.nicgw.nic.in Regional Centre at Bhuj in Gujarat	<ul style="list-style-type: none"> ⊗ AGRIS database on all aspects of agriculture from 1975 to date ⊗ Also have cell on Agriculture Research Information System; ⊗ Working on ENVIS project on desertification ⊗ Repository of information on the state of natural resources and desertification processes and their control ⊗ The spectrum of activities involves researches on basic resource inventories; monitoring of desertification, rehabilitation and management of degraded lands and other areas
8.	Central Inland Capture Fisheries Research Institute, Barrackpore- 743101, Tel#033-5600177 Fax#033-5600388 Email : cicfri@x400.nicgw.nic.in	<ul style="list-style-type: none"> ⊗ Data Base on Ecology and fisheries of major river systems of India. Biological features of commercially important riverine and estuarine fish species. Production functions and their interactions in floodplain wetlands. ⊗ Activities - Environmental Impact Assessment for Resource Management ; Fisheries Resource surveys
9.	Central Institute of Brackish Water Aquaculture 141, Marshalls Road, Egmore , Chennai - 600 008, Tel# 044-8554866, 8554891, Director (Per) 8554851 Fax#8554851,	<ul style="list-style-type: none"> ⊗ Repository of information on brackish water fishery resources with systematic database of coastal fishery resources for ARIS ⊗ Agricultural Research Information System (ARIS) database covers State wise data on soil and water quality parameters, land use pattern, production and productivity trends, ⊗ Social, economic and environmental impacts of aquaculture farming, ⊗ Guidelines and effluent standards for aquaculture farming
10.	Central Marine Fisheries Research Institute (CMFRI), Cochin	<ul style="list-style-type: none"> ⊗ Assessing and monitoring of exploited and un-exploited fish stocks in Indian EEZ ⊗ Monitoring the health of the coastal ecosystems, particularly the endangered ecosystems in relation to artisanal fishing, mechanised fishing and marine pollution ⊗ The institute has been collecting data on the catch and effort and biological characteristics for nearly half a century based on scientifically developed sampling scheme, covering all the maritime States of the country ⊗ The voluminous data available with the institute is managed by the National Marine Living Resources Data Centre (NMLRDC)
11.	Central Water and Power Research Station, Pune Tel#020-4391801-14; 4392511; 4392825 Fax #020-4392004,4390189	<ul style="list-style-type: none"> ⊗ Numerical and Physical models for hydro-dynamic simulations
12.	Central Institute of Road Transport, Bhosari, Pune 411 026, India. Tel : +91 (20) 7125177, 7125292, 7125493, 7125494	<ul style="list-style-type: none"> ⊗ Repository of data on all aspects of performance of STUs and a host of other related road transport parameters

13. Department of Ocean Development	<ul style="list-style-type: none"> ⑨ Assessment of environment parameters and marine living resources (primary and secondary) in Indian EEZ (Nodal Agency NIO Kochi) ⑨ Stock assessment, biology and resource mapping of deep sea shrimps, lobsters and fishes in Indian EEZ (Nodal agency-Fisheries Survey of India) ⑨ Investigations of toxical algal blooms and benthic productivity in Indian EEZ (Nodal agency- Cochin University of Science and technology) ⑨ Coastal Ocean Monitoring and Prediction System (COMAP) - monitoring and modelling of marine pollution along entire Indian coast and islands. Parameters monitored are temp, salinity, DO, pH, SS, BOD, inorganic phosphate, nitrate, nitrite, ammonia, total phosphorus, total nitrite, total organic carbon, petroleum hydrocarbons, pathogenic vibrios, pathogenic E.coli, shigella, salmonella, heavy metals (Cd, Hg, Pb) and pesticide residues (DDT, BHC, Endosulfan). Monitoring is carried out along the ecologically sensitive zones and urban areas (NIO Mumbai- Apex coordinating agency). ⑨ Sea Level Measurement Programme (SELMAM)- sea level measurement at selected stations (Porbandar, Bombay, Goa, Cochin, Tuticorin, Madras, Machilipatnam, Visakhapatnam, Paradeep, Calcutta and Kavaratti (Lakshadweep Island)) along Indian coast and islands using modern tide gauges ⑨ Detailed coastal maps through Survey of India showing contour at 1/2 a metre interval in the scale of 1:25000. (Nellore- Machhalipatnam work already over) ⑨ Marine Data Centre (MDC) IMD for Ocean surface meteorology, GSI for marine geology, SOI for tide levels, Naval Hydrographic Office for bathymetry, NIO Goa for physical chemical and biological oceanography, NIO Mumbai for marine pollution, CMFRI for coastal fisheries, Institute of Ocean Management Madras for coastal geomorphology ⑨ DOD has setup Indian National Centre for Ocean Information Services (INCOIS) at Hyderabad for generation and dissemination of ocean data products (near real time data products such as sea surface temperature, potential fishing zones, upwelling zones, maps, eddies, chlorophyll, suspended sediment load etc). MDC will be integrated with INCOIS ⑨ Integrated Coastal and Marine Area Management (ICMAM) programme - GIS based information system for management of 11 critical habitats namely Pichavaram, Karwar, Gulf of Mannar, Gulf of Khambat, Gulf of Kutch, Malvan, Cochin, Coringa mangroves, Gahirmata, Sunderbans and Kadamat (Lakshadweep) ⑨ Wetland maps for Tamil Nadu and Kerala showing the locations of lagoons, backwaters, estuaries, mudflats etc (1:50000 scale) ⑨ Coral Reef Maps for Gulf of Kachch, Gulf of Mannar, Andaman and Nicobar and Lakshadweep Islands (1:50,000 scale) indicating the condition of corals, density etc
14. Environment Protection Training and Research Institute Gachibowli, Hyderabad - 500 019, India Phone: +91-40-3001241, 3001242, 3000489 Fax: +91-40- 3000361 E-mail: info@eptri.com	<ul style="list-style-type: none"> ⑨ Environment Information Centre- has appointed EPTRI as the Distributed Information Centre for the Eastern Ghats region of India. EIC Collaborates with the Stockholm Environment Institute Sweden Database on Economics of Industrial Pollution Prevention in India Database of Large and Medium Scale Industries of Andhra Pradesh Environmental Status of the Hyderabad Urban Agglomeration Study on 'water pollution-health linkages' for a few Districts of A.P

		<ul style="list-style-type: none"> ⑨ Environment Quality Mapping <ul style="list-style-type: none"> Macro level studies for six districts in the State of Andhra Pradesh Micro level studies for two study zones presenting the permissible pollutant load and scoping for new industrial categories Zonation of the IDA, Parwada which helped APIIC to promote the land for industrial development Disaster management plan for Visakhapatnam Industrial Bowl Area
15.	<p>Forest Survey of India (FSI) Kaulagarh Road, P.O., IPE Dehradun - 248 195 Tel# 0135-756139, 755037, 754507 Fax # 91-135-759104 E-Mail : fsidir@nde.vsnl.net.in fsihq@nde.vsnl.net.in</p> <p>RO- Banglore, Calcutta, Nagpur and Shimla</p>	<ul style="list-style-type: none"> ⑨ State of Forest Report (Biannual) ⑨ National Forest Vegetation Map (Biannual exercise) (on 1: 1 million scale) ⑨ Thematic mapping on 1:50,000 scale depicting the forest type, species composition, crown density of forest cover and other landuse National ⑨ Basic Forest Inventory System ⑨ Inventory survey of non forest area ⑨ Forest inventory report providing details of area estimates, topographic description, health of forest, ownership pattern, estimation of volume and other growth parameters such as height and diameter in different types of forest, estimation of growth, regeneration and mortality of important species, volume equation and wood consumption of the area studied
16.	<p>Geological Survey of India 27 Jawaharlal Nehru Road, Calcutta 700 016, India Telephone +91-33- 2496941 FAX 91-33-2496956 gsi_chq@vsnl.com</p>	<ul style="list-style-type: none"> ⑨ Environmental hazards zonation mapping in mineral sector ⑨ Codification of base line information of geo-environmental appreciation of any terrain and related EIA and EMP studies ⑨ Lineament and geomorphological map of India on 1:20,000 scale. ⑨ Photo-interpreted geological and structural maps of terrains with limited field checks.
17.	<p>Indian Council of Agriculture Research, Krishi Bhawan, New Delhi, Tel#011-338206</p> <p>– ICAR complex, Goa- Agro metrology – Central Arid Zone Research Institute- Agro forestry – Central Soil salinity Research Institute, – Indian Institute of Soil Science – Central Soil and Water Conservation Research and Training Institute – National Bureau of Soil Survey and Landuse Planning</p>	<ul style="list-style-type: none"> ⑨ A total of 80,000 profiles at 10 kms grid across the country were analyzed to characterize the soils of India. ⑨ Detailed soil maps of the Country (1:7 million), State (1:250,000) and districts map (1:50,000) depicting extent of degradation (1:4.4 millions) have been prepared. ⑨ Thematic maps depicting soil depth, texture drainage, calcareousness, salinity, pH, slope and erosion have been published ⑨ Agro-climate characterization of the country based on moisture, thermal and sunshine regimes ⑨ Agro-ecological zones (20) and sub-zones (60) for the country were delineated based on physiography, soils, climate, Length of Growing Period and Available Water Content, and mapped on 1:4.4 million scale. ⑨ Digitization of physiography and soil resource base on 1:50,000 scale for 14 States have been completed. ⑨ .Soil fertility maps of N,P,K,S and Zn have also been developed ⑨ Water quality guidelines for irrigation and naturally occurring saline/sodic water ⑨ Calibration and verification of ground water models for predicting water logging and salinity hazards in irrigation commands
18.	<p>Indian Bureau of Mines Indira Bhawan, Civil Lines Nagpur Ph no - 0712-533 631, Fax- 0712-533 041</p>	<ul style="list-style-type: none"> ⑨ National mineral inventory for 61 minerals and mineral maps ⑨ Studies on environmental protection and pollution control in regard to the mining and mineral beneficiation operations ⑨ Collection, processing and storage of data on mines, minerals and mineral-based industries, collection and maintenance of world mineral intelligence, foreign mineral legislation and other related matters

19.	Indian Meteorology Department Shivaji nagar, Pune 41100 RO- Mumbai, Chennai, Calcutta, New Delhi, Nagpur, Guwahati	<ul style="list-style-type: none"> ⊙ Meteorological data ⊙ Background air quality monitoring network under Global Atmospheric Watch Programme (operates 10 stations) ⊙ Seismicity map, seismic zoning map; seismic occurrences and cyclone hazard monitoring; list of major earthquakes ⊙ Climatological Atlas of India , Rainfall Atlas of India and Agroclimatic Atlas of India ⊙ Monthly bulletin of Climate Diagnostic Bulletin of India ⊙ Environmental Meteorological Unit of IMD at Delhi to provide specific services to MoEF
20.	INTACH Natural Heritage, 71 Lodi Estate, New Delhi-110 003 Tel. 91-11-4645482, 4632267/9, 4631818, 4692774, 4641304 Fax : 91- 11-4611290 E-mail : nh@intach.net	<ul style="list-style-type: none"> ⊙ Listing and documentation of heritage sites identified by municipalities and local bodies (Listing excludes sites and buildings under the purview of the Archaeological Survey of India and the State Departments of Archaeology)
21.	Industrial Toxicology Research Centre Post Box No. 80, Mahatma Gandhi Marg, Lucknow-226001, Phone: +91-522- 221856,213618,228227; Fax : +91- 522 228227 Email: itrc@itrcindia.org	<ul style="list-style-type: none"> ⊙ Activities include health survey on occupational diseases in industrial workers, air and water quality monitoring studies, ecotoxicological impact assessment, toxicity of chemicals, human health risk assessment ⊙ Five databases on CD-ROM in the area of environmental toxicology viz: TOXLINE, CHEMBANK, POISINDEX, POLTOX and PESTBANK. The Toxicology Information Centre provides information on toxic chemicals including household chemicals ⊙ ENVIS centre and created a full-fledged computerized database (DABTOC) on toxicity profiles of about 450 chemicals
22.	Indian Institute of Forest Management Post Box No. 357, Nehru Nagar Bhopal - 462 003 Phone # 0755-575716, 573799, 765125, 767851 Fax # 0755-572878	<ul style="list-style-type: none"> ⊙ Consultancy and research on joint forest management (Ford Foundation, SIDA, GTZ, FAO etc)
23.	Indian Institute of Petroleum Mohkampur , Dehradun, India, 248005 0135- 660113 to 116 0135- 671986	<ul style="list-style-type: none"> ⊙ Fuel quality characterisation ⊙ Emission factors
24.	Ministry of Environment and Forest	<ul style="list-style-type: none"> ⊙ Survey of natural resources ⊙ National river conservation directorate ⊙ Environmental research programme for eastern and western ghats ⊙ National natural resource management system ⊙ Wetlands conservation programme- survey, demarcation, mapping landscape planning, hydrology for 20 identified wetlands National wasteland identification programme
25.	Mumbai Metropolitan Regional Development Authority	<ul style="list-style-type: none"> ⊙ Mumbai Urban Transport Project ⊙ Mumbai Urban Development Project ⊙ Mumbai Urban Rehabilitation Project ⊙ Information on MMR; statistics on councils and corporations Regional Information Centre- Basic data on population, employment, industries and other sectors are regularly collected and processed

26.	Municipal Corporation of Greater Mumbai	<ul style="list-style-type: none"> ⊙ Air Quality Data for Mumbai Municipal Area ⊙ Water quality of lakes used for water supply to Mumbai
27.	Ministry of Urban Development Disaster Mitigation and Vulnerability Atlas of India Building Materials & Technology Promotion Council G-Wing, Nirman Bhavan, New Delhi-110011 Tel: 91-11-3019367 Fax: 91-11-3010145 E-Mail: bmtpc@del2.vsnl.net.in	<ul style="list-style-type: none"> ⊙ Identification of hazard prone area ⊙ Vulnerability Atlas showing areas vulnerable to natural disasters ⊙ Land-use zoning and design guidelines for improving hazard resistant construction of buildings and housing ⊙ State wise hazard maps (on cyclone, floods and earthquakes)
28.	Natural Disaster Management Division in Department of Agriculture and Cooperation	<ul style="list-style-type: none"> ⊙ Weekly situation reports on recent disasters, reports on droughts, floods, cyclones and earthquakes
29.	National Bureau Of Soil Survey & Land Use Planning P.O. Box No. 426, Shankar Nagar P.O., Nagpur-440010 Tel#91-712-534664,532438,534545 Fax#:91-712-522534 RO- Nagpur, New Delhi, Bangalore, Calcutta, Jorhat, Udaipur	<ul style="list-style-type: none"> ⊙ NBSS&LUP Library has been identified as sub centre of ARIC (ICAR) for input to AGRIS covering soil science literature generated in India ⊙ Research in weathering and soil formation, soil morphology, soil mineralogy, physicochemical characterisation, pedogenesis, and landscape-climate-soil relationship. ⊙ Soil Series of India- The soils are classified as per Soil Taxonomy. The described soil series now belong to 17 States of the country. ⊙ Landuse planning- watershed management, land evaluation criteria, crop efficiency zoning ⊙ Soil Information system is developed state-wise at 1:250,000 scale. Presently the soil maps of all the States are digitized, processed and designed for final output both digital and hardcopy. The thematic layers and interpreted layers of land evaluation (land capability, land irrigability and crop suitability), Agro-Ecological Zones and soil degradation themes are prepared. ⊙ Districts level information system is developed for about 15 districts at 1:50,000 scale. The soil information will be at soil series level in this system. Soil resource inventory of States, districts water-sheds (1:250,000; 1:50,000; 1:10,000/8000)
30.	National Institute of Ocean Technology, Velacherry-Tambaram main road Narayanapuram Chennai, Tamil Nadu Tel#91-44-2460063 / 2460064/ 2460066/ 2460067 Fax#91-44-2460645	<ul style="list-style-type: none"> ⊙ Waste load allocation in selected estuaries (Tapi estuary and Ennore creek) is one the components under the Integrated Coastal and Marine Area Management (ICMAM) programme of the Department of Ocean Development ICMAM is conducted with an IDA based credit to the Government of India under the Environmental Capacity Building project of MoEF (waste assimilation capacity of Ennore creek is over) ⊙ Physical oceanographic component of Coastal & Ocean monitoring Predictive System (COMAPS) a long term monitoring program under the Department of Ocean Development ⊙ Identification of suitable locations for disposal of dredge spoil using mathematical models & environmental criteria ⊙ EIA Manual and EIA guidelines for port and harbour projects
31.	National Institute of Oceanography, Goa RO- Mumbai, Kochi	<ul style="list-style-type: none"> ⊙ Coastal Ocean Monitoring and Predictions(COMAP)-Monitoring of coastal waters for physicochemical and biological parameters including petroleum hydrocarbons, trace metals, heavy metals, and biomass of primary (phytoplankton) and secondary (zooplankton, microbial and benthic organisms) ⊙ Marine Biodiversity of selected ecosystem along the West Coast of India

32.	National Botanical Research Institute, Post Box No 436 Rana Pratap Marg Lucknow- 226001, Tel: (+91) 522 271031-35 Fax: (+91) 522 282849, 282881 Lucknow	<ul style="list-style-type: none"> ⊗ Dust filtering potential of common avenue trees and roadside shrubs has been determined, besides studies have also been conducted on heavy-metals accumulation potential of aquatic plants supposedly useful as indicators of heavy metal pollution in water bodies and capable of reducing the toxic metals from water bodies. ⊗ Assessment of bio-diversity of various regions of India
33.	National Geophysical Research Institute, Uppal Road, Hyderabad Telephone:0091-40-7171124, FAX:0091-40-7171564	<ul style="list-style-type: none"> ⊗ Exploration, assessment and management of ground water resources including ground water modelling and pollution studies
34.	National Environmental Engineering Research Institute, Nagpur RO- Mumbai, Delhi, Chennai, Calcutta, Ahmedabad, Cochin, Hyderabad, Kanpur	<ul style="list-style-type: none"> ⊗ National Air Quality Monitoring (NAQM) for CPCB ⊗ Database on cleaner technologies of industrial productions
35.	National Hydrology Institute, Roorkee RO- Belgaum (Hard Rock Regional Centre), Jammu (Western Himalayan Regional Centre), Guwahati (North Eastern Regional Centre), Kakinada (Deltaic Regional Centre), Patna (Ganga Plains North Regional Centre), and Sagar (Ganga Plains South)	<ul style="list-style-type: none"> ⊗ Basin studies, hydrometeorological network improvement, hydrological year book, hydrological modelling, regional flood formulae, reservoir sedimentation studies, environmental hydrology, watershed development studies, tank studies, and drought studies.
36.	National Institute Of Urban Affairs, India Habitat Centre, New Delhi	<ul style="list-style-type: none"> ⊗ Urban Statistics Handbook
37.	National Institute of Occupational Health Meghaninagar, Ahmedabad RO- Banglore, Calcutta	<ul style="list-style-type: none"> ⊗ epidemiological studies and surveillance of hazardous occupations including air pollution, noise pollution, agricultural hazards, industrial hazards in organised sectors as well as small scale industries, carcinogenesis, pesticide toxicology, etc ⊗ WHO collaborative centre for occupational health for South East Asia region and the lead institute for the international programme on chemical safety under IPCS (WHO)
38.	NRSA Data Centre Department of Space, Balanagar, Hyderabad 500 037 Ph- 040-3078560 3078664 sales@nrsa.gov.in	<ul style="list-style-type: none"> ⊗ Satellite data products (raw data, partially processed (radiometrically corrected but geometrically uncorrected), standard data (radiometrically and geometrically corrected), geocoded data(1:50,000 and 1:25000 scale), special data products like mosaiced, merged and extracted) available on photographic (B&W and FCC in form of film of 240 mm X 240mm or enlargements/paper prints in scale varying between 1:1M and 1:12500 and size varying between 240mm and 1000mm) and digital media (CD-ROMs, 8 mm tapes)
39.	Rajiv Gandhi National Drinking Water Mission	<ul style="list-style-type: none"> ⊗ Database for groundwater using remote sensing technology (Regional Remote Sensing Service Centre involved in generation of ground water prospect maps at 1:50,000 scale for the State of Kerala, Karnataka, AP, MP and Rajasthan for RGNDWM)
40.	Space Application Centre Value Added Services Cell (VASC) Remote Sensing Application Area Ahmedabad 380 053 079-676 1188	<ul style="list-style-type: none"> ⊗ National Natural Resource Information System ⊗ Landuse mapping for coastal regulation zone (construction setback line) upto 1:12500 scale ⊗ Inventory of coastal wetlands, coral reefs, mangroves, seaweeds ⊗ Monitoring and condition assessment of protected coastal areas

	Fax- 079-6762735	<ul style="list-style-type: none"> ⊙ Wetland mapping and inventory ⊙ Mapping of potential hotspots and zoning of environmental hazards ⊙ General geological and geomorphological mapping in diverse terrain ⊙ Landslide risk zonation for Tehre area
41.	State Pollution Control Board	<ul style="list-style-type: none"> ⊙ State Air Quality Monitoring Programme ⊙ Inventory of polluting industries ⊙ Identification and authorization of hazardous waste generating industries ⊙ Inventory of biomedical waste generating industries ⊙ Water quality monitoring of water bodies receiving wastewater discharges ⊙ Inventory of air polluting industries ⊙ Industrial air pollution monitoring ⊙ Air consent, water consent, authorization, environment monitoring reports
42.	State Ground Water Board	
43.	Survey of India	<ul style="list-style-type: none"> ⊙ Topographical surveys on 1:250,000 scales, 1:50,000 and 1:25,000 scales ⊙ Digital Cartographical Data Base of topographical maps on scales 1:250,000 and 1:50,000 ⊙ Data generation and its processing for redefinition of Indian Geodetic Datum ⊙ Maintenance of National Tidal Data Centre and receiving/ processing of tidal data of various ports. ⊙ Coastal mapping along the Eastern coast line has been in progress to study the effect of submergence due to rise in sea-level and other natural phenomenon. Ground surveys have been completed for the proposed coastal region and maps are under printing. ⊙ District planning maps containing thematic information (135 maps) have been printed out of 249 maps covering half the districts of India. Districts planning maps for remaining half of the area are being processed by National Atlas and Thematic Mapping Organisation (NATMO)
44.	Town and Country Planning Organisation	<ul style="list-style-type: none"> ⊙ Urban mapping - Thematic maps and graphic database on towns (under progress in association with NRSA and State town planning department)
45.	Wildlife Institute of India Post Bag No. 18, Chandrabani Dehradun - 248 001, Uttaranchal Tel#0135 640111 -15, Fax#0135 640117 email : wii@wii .	<ul style="list-style-type: none"> ⊙ Provide information and advice on specific wildlife management problems. ⊙ National Wildlife Database
46.	Zoological Survey of India Prani Vigyan Bhawan 'M' Block, New Alipore Calcutta - 700 053 Phone # 91-33-4786893, 4783383 Fax # 91-33-786893 RO - Shillong, Pune, Dehradun, Jabalpur, Jodhpur, Chennai, Patna, Hyderabad, Canning, Behrampur, Kozikode, Itanagar, Digha, Port Blair, Solan	<ul style="list-style-type: none"> ⊙ Red Book for listing of endemic species ⊙ Survey of faunal resources

ANNEXURE IX
Impact Prediction Tools

Table 1: Choice of Models for Impact Prediction: Air Environment*

Model	Application	Remarks
ISCST 3	<ul style="list-style-type: none"> ▪ Appropriate for point, area and line sources ▪ Application for flat or rolling terrain ▪ Transport distance up to 50 km valid ▪ Computes for 1 hr to annual averaging periods 	<ul style="list-style-type: none"> ▪ Can take up to 99 sources ▪ Computes concentration on 600 receptors in Cartesian on polar coordinate system ▪ Can take receptor elevation ▪ Requires source data, meteorological and receptor data as input.
AERMOD with AERMET	<ul style="list-style-type: none"> ▪ Settling and dry deposition of particles; ▪ Building wake effects (excluding cavity region impacts); ▪ Point, area, line, and volume sources; ▪ Plume rise as a function of downwind distance; ▪ Multiple point, area, line, or volume sources; ▪ Limited terrain adjustment; ▪ Long-term and short-term averaging modes; ▪ Rural or urban modes; ▪ Variable receptor grid density; ▪ Actual hourly meteorology data 	<ul style="list-style-type: none"> ▪ Can take up to 99 sources ▪ Computes concentration on 600 receptors in Cartesian on polar coordinate system ▪ Can take receptor elevation ▪ Requires source data, meteorological and receptor data as input.
PTMAX	<ul style="list-style-type: none"> ▪ Screening model applicable for a single point source ▪ Computes maximum concentration and distance of maximum concentration occurrence as a function of wind speed and stability class 	<ul style="list-style-type: none"> ▪ Require source characteristics ▪ No met data required ▪ Used mainly for ambient air monitoring network design
PTDIS	<ul style="list-style-type: none"> ▪ Screening model applicable for a single point source ▪ Computes maximum pollutant concentration and its occurrences for the prevailing meteorological conditions 	<ul style="list-style-type: none"> ▪ Require source characteristics ▪ Average met data (wind speed, temperature, stability class <i>etc.</i>) required ▪ Used mainly to see likely impact of a single source
MPTER	<ul style="list-style-type: none"> ▪ Appropriate for point, area and line sources applicable for flat or rolling terrain ▪ Transport distance up to 50 km valid ▪ Computes for 1 hr to annual averaging periods ▪ Terrain adjustment is possible 	<ul style="list-style-type: none"> ▪ Can take 250 sources ▪ Computes concentration at 180 receptors up to 10 km ▪ Requires source data, meteorological data and receptor coordinates
CTDM PLUS (Complex Terrain Dispersion Model)	<ul style="list-style-type: none"> ▪ Point source steady state model, can estimate hrly average concentration in isolated hills/ array of hills 	<ul style="list-style-type: none"> ▪ Can take maximum 40 Stacks and computes concentration at maximum 400 receptors ▪ Does not simulate calm met conditions ▪ Hill slopes are assumed not to exceed 15 degrees ▪ Requires sources, met and terrain characteristics and receptor details
UAM (Urban Airshed Model)	<ul style="list-style-type: none"> ▪ 3-D grid type numerical simulation model ▪ Computes O₃ concentration short term episodic conditions lasting for 1 or 2 days resulting from NO_x and VOCs ▪ Appropriate for single urban area having significant O₃ problems 	<ul style="list-style-type: none"> ▪

Model	Application	Remarks
RAM (Rural Airshed Model)	<ul style="list-style-type: none"> ▪ Steady state Gaussian plume model for computing concentration of relatively stable pollutants for 1 hr to 1 day averaging time ▪ Application for point and area sources in rural and urban setting 	<ul style="list-style-type: none"> ▪ Suitable for flat terrains ▪ Transport distance less than 50 km.
CRESTER	<ul style="list-style-type: none"> ▪ Applicable for single point source either in rural or urban setting ▪ Computes highest and second highest concentration for 1hr, 3hr, 24hr and annual averaging times ▪ Tabulates 50 highest concentration for entire year for each averaging times 	<ul style="list-style-type: none"> ▪ Can take up to 19 Stacks simultaneously at a common site. ▪ Unsuitable for cool and high velocity emissions ▪ Do not account for tall buildings or topographic features ▪ Computes concentration at 180 receptor, circular wing at five downwind ring distance 36 radials ▪ Require sources, and met data
OCD (Offshore and coastal Dispersion Model)	<ul style="list-style-type: none"> ▪ It determines the impact of offshore emissions from point sources on the air quality of coastal regions ▪ It incorporates overwater plume transport and dispersion as well as changes that occur as the plume crosses the shore line ▪ Most suitable for overwater sources shore onshore receptors are below the lowest shore height 	<ul style="list-style-type: none"> ▪ Requires source emission data ▪ Require hrly met data at offshore and onshore locations like water surface temperature; overwater air temperature; relative humidity <i>etc.</i>
FDM (Fugitive Dust Model)	<ul style="list-style-type: none"> ▪ Suitable for emissions from fugitive dust sources ▪ Source may be point, area or line (up to 121 source) ▪ Require particle size classification max. up to 20 sizes ▪ Computes concentrations for 1 hr, 3hr, 8hr, 24hr or annual average periods 	<ul style="list-style-type: none"> ▪ Require dust source particle sizes ▪ Source coordinates for area sources, source height and geographic details ▪ Can compute concentration at max. 1200 receptors ▪ Require met data (wind direction, speed, Temperature, mixing height and stability class) ▪ Model do not include buoyant point sources, hence no plume rise algorithm
RTDM (Rough Terrain Diffusion Model)	<ul style="list-style-type: none"> ▪ Estimates GLC is complex/rough (or flat) terrain in the vicinity of one or more co-located point sources ▪ Transport distance max. up to 15 km to up to 50 km ▪ Computes for 1 to 24 hr. or annual average concentrations 	<ul style="list-style-type: none"> ▪ Can take up to 35 co-located point sources ▪ Require source data and hourly met data ▪ Computes concentration at maximum 400 receptors ▪ Suitable only for non reactive gases ▪ Do not include gravitational effects or depletion mechanism such as rain/ wash out, dry deposition
CDM(Climatologically Dispersion Model)	<ul style="list-style-type: none"> ▪ It is a climatologically steady state GPM for determining long term (seasonal or annual) ▪ Arithmetic average pollutant concentration at any ground level receptor in an urban area 	<ul style="list-style-type: none"> ▪ Suitable for point and area sources in urban region, flat terrain ▪ Valid for transport distance less than 50 km ▪ Long term averages: One month to one year or longer
PLUVUE-II (Plume Visibility Model)	<ul style="list-style-type: none"> ▪ Applicable to assess visibility impairment due to pollutants emitted from well defined point sources ▪ It is used to calculate visual range reduction 	<ul style="list-style-type: none"> ▪ Require source characteristics, met data and receptor coordinates & elevation ▪ Require atmospheric aerosols

Model	Application	Remarks
	<p>and atmospheric discoloration caused by plumes</p> <ul style="list-style-type: none"> It predicts transport, atmospheric diffusion, chemical, conversion, optical effects, and surface deposition of point source emissions. 	<p>(back ground & emitted) characteristics, like density, particle size</p> <ul style="list-style-type: none"> Require background pollutant concentration of SO₄, NO₃, NO_x, NO₂, O₃, SO₂ and deposition velocities of SO₂, NO₂ and aerosols
MESO-PUFF II (Meso scale Puff Model)	<ul style="list-style-type: none"> It is a Gaussian, Variable trajectory, puff superposition model designed to account for spatial and temporal variations in transport, diffusion, chemical transformation and removal mechanism encountered on regional scale. Plume is modeled as a series of discrete puffs and each puff is transported independently Appropriate for point and area sources in urban areas Regional scale model. 	<ul style="list-style-type: none"> Can model five pollutants simultaneously (SO₂, SO₄, NO_x, HNO₃ and NO₃) Require source characteristics Can take 20 point sources or 5 area source For area source – location, effective height, initial puff size, emission is required Computes pollutant concentration at max. 180 discrete receptors and 1600 (40 x 40) grided receptors Require hourly surface data including cloud cover and twice a day upper air data (pressure, temp, height, wind speed, direction) Do not include gravitational effects or depletion mechanism such as rain/ wash out, dry deposition

Table 2: Choice of Models for Impact Modeling: Noise Environment*

Model	Application
FHWA (Federal Highway Administration)	Noise Impact due to vehicular movement on highways
Dhwani	For predictions of impact due to group of noise sources in the industrial complex (multiple sound sources)
Hemispherical sound wave propagation Air Port	Fore predictive impact due to single noise source For predictive impact of traffic on airport and rail road

Table 3: Choice of Models for Impact Modeling: Land Environment*

Model	Application	Remarks
Digital Analysis Techniques	Provides land use / land cover distribution	
Ranking analysis for soil suitability criteria	Provides suitability criteria for developmental conversation activities	Various parameters viz. depth, texture, slope, erosion status, geomorphology, flooding hazards, GW potential, land use <i>etc.</i> , are used.

Table 4: Choice of Models for Impact Modeling: Water Environment*

Model	Application	Remarks
QUAL-II E	Wind effect is insignificant, vertical dispersive effects insignificant applicable to streams Data required Deoxygenation coefficients, re-aeration coefficients for carbonaceous, nitrogenous and benthic substances, dissolved oxygen deficit	Steady state or dynamic model
	The model is found excellent to generate water quality parameters Photosynthetic and respiration rate of suspended and attached algae	
	Parameters measured up to 15 component can be simulated in any combination, e.g. ammonia, nitrite, nitrate, phosphorous, carbonaceous BOD, benthic oxygen demand, DO, coliforms, conservative substances and temperature	
DOSAG-3, USEPA: (1-D) RECEIV – II, USEPA	Water quality simulation model for streams & canal A general Water quality model	Steady-state
Explore –I, USEPA	A river basin water quality model	Dynamic, Simple hydrodynamics
HSPE, USEPA	Hydrologic simulation model	Dynamic, Simple hydrodynamics
RECEIVE-II, USEPA	A general dynamic planning model for water quality management	
Stanford watershed model	This model simulates stream flows once historic precipitation data are supplied The major components of the hydrologic cycle are modeled including interception, surface detention, overland inflow, groundwater, evapo-transpiration and routing of channel flows, temperature, TDS, DO, carbonaceous BOD coliforms, algae, zooplanktons, nitrite, nitrate, ammonia, phosphate and conservative substances can be simulated	
Hydrocomp model	Long-term meteorological and wastewater characterization data is used to simulate stream flows and stream water quality	Time dependant (Dynamic)
Stormwater Management model (SWMM)	Runoff is modeled from overland flow, through surface channels, and through sewer network Both combined and separate sewers can be modeled. This model also enables to simulate water quality effects to stormwater or combined sewer discharges. This model simulates runoff resulting from individual rainfall events.	Time Dependent
Battelle Reservoir model	Water body is divided into segments along the direction of the flow and each segment is divided into number of horizontal layers. The model is found to generate excellent simulation of temperature and good prediction of water quality parameters. The model simulates temperature, DO, total and	Two Dimensional multi-segment model

Model	Application	Remarks
	benthic BOD, phytoplankton, zooplankton, organic and inorganic nitrogen, phosphorous, coliform bacteria, toxic substances and hydrodynamic conditions.	
TIDEP (Turbulent diffusion temperature model reservoirs)	Horizontal temperature homogeneity Coefficient of vertical turbulent diffusion constant for charge of area with depth negligible coefficient of thermal exchange constant Data required wind speed, air temperature, air humidity, net incoming radiation, surface water temperature, heat exchange coefficients and vertical turbulent diffusion coefficients.	Steady state model
BIOLAKE	Model estimates potential fish harvest from a take	Steady state model
Estuary models/ estuarial Dynamic model	It is simulates tides, currents, and discharge in shallow, vertically mixed estuaries excited by ocean tides, hydrologic influx, and wind action Tides, currents in estuary are simulated	Dynamic model
Dynamic Water Quality Model	It simulates the mass transport of either conservative or non-conservative quality constituents utilizing information derived from the hydrodynamic model Bay-Delta model is the programme generally used. Up to 10 independent quality parameters of either conservative or non-conservative type plus the BOD-DO coupled relationship can be handled	Dynamic model
HEC -2	To compute water surface profiles for steady, gradually: varying flow in both prismatic & non-prismatic channels	
SMS	Lake circulation, salt water intrusion, surface water profile simulation model	Surface water Modeling system Hydrodynamic model
RMA2	To compute flow velocities and water surface elevations	Hydrodynamic analysis model
RMA4	Solves advective-diffusion equations to model up to six non-interacting constituents	Constituent transport model
SED2D-WES	Model simulates transport of sediment	Sediment transport model
HIVEL2D	Model supports subcritical and supercritical flow analysis	A 2-dimensional hydrodynamic model
MIKE-II, DHI	Model supports, simulations of flows, water quality, and sediment transport in estuaries, rivers, irrigation systems, channels & other water bodies	Professional Engineering software package

Table 5: Choice of Models for Impact Modeling: Biological Environment*

Name	Relevance	Applications	Remarks
Flora			
Sample plot methods	Density and relative density	Average number of individuals species per unit area	The quadrant sampling technique is applicable in all types of plant communities and for the study of submerged, sessile (attached at the base) or
	Density and relative	Relative degree to which a	

Name	Relevance	Applications	Remarks
	dominance	species predominates a community by its sheer numbers, size bulk or biomass	sedentary plants
	Frequency and relative frequency importance value	Plant dispersion over an area or within a community	Commonly accepted plot size: 0.1 m ² - mosses, lichens & other mat-like plants
		Average of relative density, relative dominance and relative frequency	0.1 m ² - herbaceous vegetation including grasses
			10.20 m ² – for shrubs and saplings up to 3m tall, and
			100 m ² – for tree communities
Transects & line intercepts methods	Cover	Ratio of total amount of line intercepted by each species and total length of the line intercept given its cover	This methods allows for rapid assessment of vegetation transition zones, and requires minimum time or equipment of establish
	Relative dominance	It is the ratio of total individuals of a species and total individuals of all species	Two or more vegetation strata can be sampled simultaneously
Plot-less sampling methods	Mean point plant Mean area per plant	Mean point – plant distance Mean area per plant	Vegetation measurements are determined from points rather than being determined in an area with boundaries
	Density and relative density		Method is used in grass-land and open shrub and tree communities
	Dominance and relative dominance		It allows more rapid and extensive sampling than the plot method
	Importance value		Point- quarter method is commonly used in woods and forests.
Fauna			
Species list methods	Animal species list	List of animal communities observed directly	Animal species lists present common and scientific names of the species involved so that the faunal resources of the area are catalogued
Direct Contact Methods	Animal species list	List of animals communities observed directly	This method involves collection, study and release of animals
Count indices methods (Roadside and aerial count methods)	Drive counts Temporal counts	Observation of animals by driving them past trained observers	Count indices provide estimates of animal populations and are obtained from signs, calls or trailside counts or roadside counts
	Call counts	Count of all animals passing a fixed point during some stated	These estimates, through they do not provide absolute population

Name	Relevance	Applications	Remarks
		interval of time	numbers, Provide an index of the various species in an area
			Such indices allow comparisons through the seasons or between sites or habitats
Removal methods	Population size	Number of species captured	Removal methods are used to obtain population estimates of small mammals, such as, rodents through baited snap traps
Market capture methods	Population size estimate (M)	Number of species originally marked (T) Number of marked animals recaptured (t) and total number of animals captured during census (n) $N = nT/t$	It involves capturing a portion of the population and at some later date sampling the ratio of marked to total animals caught in the population

Table 6: Choice of Models for Impact Predictions: Socio-economic Environment*

Relevance		
Name	Application	Remarks
Extrapolative Methods	A prediction is made that is consistent with past and present socio-economic data, e.g. a prediction based on the linear extrapolation of current trends	
Intuitive Forecasting (Delphi techniques)	Delphi technique is used to determine environmental priorities and also to make intuitive predictions through the process of achieving group consensus	Conjecture Brainstorming Heuristic programming Delphi consensus
Trend extrapolation and correlation	Predictions may be obtained by extrapolating present trends Not an accurate method of making socio-economic forecasts, because a time series cannot be interpreted or extrapolated very far into the future with out some knowledge of the underlying physical, biological, and social factors	Trend breakthrough precursor events correlation and regression
Metaphors and analogies	The experience gained else where is used to predict the socio-economic impacts	Growth historical simulation commonsense forecasts
Scenarios	Scenarios are common-sense forecasts of data. Each scenario is logically constructed on model of a potential future for which the degrees of "confidence" as to progression and outcome remain undefined	Common-sense
Dynamic modeling (Input- Out model)	Model predicts net economic gain to the society after considering all inputs required for conversion of raw materials along with cost of finished product	
Normative Methods	Desired socio-economic goals are specified and an attempt is made to project the social environment backward in time to the present to examine whether existing or planned resources and	Morphological analysis technology scanning contextual mapping - functional array

Relevance		
Name	Application	Remarks
	environmental programmes are adequate to meet the goals	- graphic method Mission networks and functional arrays decision trees & relevance trees matrix methods scenarios

* **NOTE:** (i) If a project proponent prefer to use any model other than listed, can do so, with prior concurrence of concerned appraisal committee. (ii) Project-specific proposed prediction tools need to be identified by the project proponent and shall be incorporated in the draft ToR to be submitted to the Authority for the consideration and approval by the concerned EAC/SEAC.

ANNEXURE X

**Form through which the State Governments/Administration of
the Union Territories Submit Nominations for SEIAA and SEAC
for the Consideration and Notification by the
Central Government**

Form for Nomination of a professional/expert as Chairperson / Member / Secretary of the SEIAA / EAC / SEAC						
1 Name (in block letters)						
2 Address for communication						
3 Age & Date of Birth (Shall be less than 67 years for the members and 72 years for the Chairman)						
4 Area of Expertise (As per Appendix VI)						
5	Professional Qualifications (As per Appendix VI)	Qualification(s)	University	Year of passing	Percentage of marks	
6	Work experience (High light relevant experience as per Appendix VI)	Position	Years of association		Nature of work. If required, attach separate sheets	
			From	to		Period in years
7	Present position and nature of job	Serving Central / State Government Office?			Yes/No	
		Engaged in industry or their associations?			Yes/No	
		Associated with environmental activism?			Yes/No	
		If no is the answer for above three, please specify the present position and name of the organization				
8	Whether experienced in the process of prior environmental clearance?	Yes/No. If yes, please specify the experience in a separate sheet (Please restrict to 500 words)				
9	Whether any out-standing expertise has been acquired?	Yes/ No If yes, please provide details in a separate sheet (Please restrict to 500 words).				
10	Any other relevant information?	May like to attach separate sheets (Research projects, consultancy projects, publications, memberships in associations, trainings undergone, international exposure cum experience etc.)				

The Government of.....is pleased to forward the Nomination of Dr./Sh. for the position of Chairperson / Member / Secretary of the SEIAA / SEAC / EAC to the Ministry of Environment & Forests, the Government of India for the Notification.

(Authorized Signature with Seal)

ANNEXURE XI
Composition of EAC/SEAC

Composition of the EAC/SEAC

The Members of the EAC shall be Experts with the requisite expertise and experience in the following fields /disciplines. In the event that persons fulfilling the criteria of “Experts” are not available, Professionals in the same field with sufficient experience may be considered:

- Environment Quality Experts: Experts in measurement/monitoring, analysis and interpretation of data in relation to environmental quality
- Sectoral Experts in Project Management: Experts in Project Management or Management of Process/Operations/Facilities in the relevant sectors.
- Environmental Impact Assessment Process Experts: Experts in conducting and carrying out Environmental Impact Assessments (EIAs) and preparation of Environmental Management Plans (EMPs) and other Management plans and who have wide expertise and knowledge of predictive techniques and tools used in the EIA process
- Risk Assessment Experts
- Life Science Experts in floral and faunal management
- Forestry and Wildlife Experts
- Environmental Economics Expert with experience in project appraisal

ANNEXURE XII

Best Practices & Latest Technologies available and reference

Technological Aspects

Natural resource conservation

It includes protection and conservation of aquatic, land, material, food and agricultural resources for socio-economic benefits. Wastewater and other materials which are released during the manufacturing process should be recovered, recycled, and reused to minimize input material *i.e.*, water, raw material, energy requirement in the process. Such practices in chlor-alkali industry conserve resources and in turn reduce pollution through emission of mercury, chlorine, salt, and other material loss. Siting of chlor-alkali industry is a means to conserve fresh water resources *i.e.*, as far as possible restrict siting such industries in fresh water geographical region to avoid deterioration of groundwater due to disposal of high total dissolved solids (TDS) waste. Such industrial site may be more suitable in coastal areas.

The use of hydrogen gas (unutilized one), free-from-mercury, can be used as a fuel to save fossil fuel. Conservation of building, fabric material and agriculture may be given due care. Avoiding chlorine gas leaks in the vicinity of industry may also be taken care of. Adoption of cleaner technologies, which are more energy-efficient, should be encouraged. MBCP is more economical from energy & fossil fuel conservation point-of-view when compared to MRCP and DCP techniques.

Cleaner technologies

Implementation of cleaner processes and pollution prevention measures can yield both economic and environmental benefits.

In MBCP (membrane process), the chlorine (at the anode) and the hydrogen (at the cathode) are kept apart by a selective polymer membrane that allows sodium ions to pass into the cathodic compartment and react with the hydroxyl ions to form caustic soda. The depleted brine is de-chlorinated and recycled to the input stage. The major waste stream from the MBCP consists of brine mud - the sludge from the brine purification step, which may contain magnesium, calcium, iron, and other metal hydroxides, depending on the source and purity of the brine.

Pollution prevention technologies

The pollution emission target namely wastewater generation target of 0.1 m³ per tonne of chlorine produced can be achieved by adopting preventive measures such as:

- Having an emergency preparedness and response plan for potential uncontrolled chlorine and other releases.
- Using carbon tetrachloride with levels below 4% to avoid explosion.
- Using metal rather than graphite anodes in DCP to reduce lead and chlorinated organics.
- Re-saturate brine in closed vessels to reduce the generation of salt sprays.
- Use non-contact condensers to reduce the amount of process wastewater.
- Scrub chlorine tail-gases to reduce chlorine discharges and to produce hypochlorite. Scrub chlorine tail-gas using suitable quantity of water for preparation of caustic solution for pH maintenance to reduce chlorine discharge and to produce sodium hypo chloride
- Recycle condensates and waste process water to the brine system, if possible.
- Recycle brine wastes, if possible
- Preferable use of substitutes for carbon tetrachloride as this is hazardous

MBCP manufacturing process

For MBCP (membrane technology) the cleaner options include:

- Minimizing the discharge of chlorate and bromate to water by applying: acid conditions in the anolyte (pH:1-2) to minimize the formation of chlorate (ClO_3^-) and bromate (BrO_3^-) – chlorate destruction in the brine circuit to remove chlorate before purging.
- The acidity of the anolyte is a design parameter of membrane cell plants and cannot be adjusted without affecting the operation of the membrane cell. If this is not the chosen option, a chlorate decomposer may be necessary to remove chlorate before purging.
- The chlorate level associated with BAT in the brine circuit is 1-5 g/l and the associated bromate level is 2-10 mg/l (note that the bromate level depends on the bromide level in the salt).
- Appropriate handling of spent membranes and gaskets.

New emerging cleaner technologies

A number of new promising techniques are being developed with energy saving as the main driving force. Some of these new techniques for the MBCP and DCP techniques are described below:

- Fundamental research programmes related to mercury technology are not being developed since it is very unlikely that any new mercury plants will be built. The only recent improvements in mercury cells concerns the anode geometry with the aim of improving gas release in order to decrease electrical energy usage and increase anode coating life. In diaphragm technology, with the exception of non-asbestos technology referred earlier, improvements are minor and related to reducing power consumption in the cell. An interesting example is a specific development of activated cathode technology which is the pre-cathode concept.

- Oxygen depolarized cathodes in membrane cells have the potential to save around 500-600 kWh/tonne of chlorine produced and are now being tested at the industrial scale.
- The membrane is being developed that can produce high concentration (50%) caustic soda and believes that it could be available at an acceptable cost within a few years.

Waste minimization opportunities

Complete recycling of mercury-bearing effluent should be done. In order to minimize mercury concentration in the wastewater at 0.01 mg/l, online/automatic mercury monitoring may be put in place to take necessary measures for complete recycling of wastewater or maintaining the effluent requirement. Condensate from cooling of hydrogen and chlorine demister drainage water may be circulated to the brine system to minimize water use. To minimize mercury in brine mud, automatic short-circuiting prevention devices may be placed.

Proper measures may be taken to convert mercury into a soluble complex ion which does not precipitate and also not lost by evaporation. To minimize loss of mercury into air, the floor of the cell room may be provided with epoxy resin for good collection of spilled mercury by vacuum pump. Equipment such as end box, caustic exit of the composer, caustic receiver tank and end box washing water receiving tank should be kept under negative pressure and the resulting gas may be washed in the hypo chloride tower following further treatment by activated carbon/ion-exchange resin. The sludge from different parts contaminated with high-level of mercury should be subjected for mercury recovery by heating and distillation.

Shifting from MRCP to MBCP technique

When chlor-alkali plants replace mercury cells with alternative technologies, thousands of tonnes of mercury have to be disposed of as hazardous waste. There is currently no approved disposal method for mercury; only recovery/recycling of mercury is the best option.

The three major pollutants of MRCP air emissions are the (1) by-product hydrogen stream, (2) end box ventilation air and (3) cell room ventilation air.

The by-product hydrogen stream from the decomposer is saturated with mercury vapor and may also contain fine droplets of liquid mercury. The quantity of mercury emitted in the end box ventilation air depends on the degree of mercury saturation and the volumetric flow rate of the air. The amount of mercury in the cell room ventilation air varies widely because of fugitive nature from large number of sources, including, maintenance operations, mercury spills, equipment leaks, cell failure, *etc.* MRCP chlor-alkali facilities should first use pollution prevention methods to minimize fugitive mercury emissions to the environment. Concentrations are to be minimized through practice of good housekeeping methods and equipment maintenance procedures while taking care to keep the worker exposure levels to minimum. Mercury emissions via the cell room air circulation are not subject to specific emission control measures.

The control techniques that are typically used to reduce the level of mercury in the hydrogen streams and in the ventilation stream from the end boxes are these: (1) gas stream cooling, (2) mist eliminators, (3) scrubbers, and (4) adsorption on activated carbon or molecular sieves.

Sulfur and iodine-impregnated carbon adsorption systems are commonly used to reduce the mercury levels in the hydrogen gas stream if high removal efficiencies are desired. This method requires pre-treatment of the gas stream by primary or secondary cooling followed by mist eliminators to remove about 90% of the mercury content of the gas stream. As the gas stream passes through the carbon adsorber, the mercury vapor is initially adsorbed by the carbon and then reacts with sulfur or iodine, to form the corresponding mercury sulfides or iodides.

Pollution control technologies

As far as treatment of waste generated is concerned, the mud generated is normally filtered or settled, where as, the supernatant are recycled, and the mud is dried and land-filled. Chlorine is a highly toxic gas, and strict precautions are necessary to minimize risk to workers and possible fugitive releases during its handling.

There are number of point sources from where mercury emanates through wastewater. These are brine purification units and brine storage tank, cell room washing, cell cleaning & end box washing, mercury spillage during mercury handling and transfer, washing of caustic soda filter, washing of secondary cell components *etc.* Most of the mercury losses can be controlled by good housekeeping and in-plant control measures. The total mercury bearing effluents are to be segregated for cost-effective treatment for removal of mercury. There are a number of techniques used to control mercury emission from wastewater. These are mercury – amalgamation (reduction method, sulphide treatment, ion exchange resin and activated carbon column system for treatment. The ion exchange resin and activated carbon system for de-mercurisation are the most effective and economically feasible control technology, can be either adopted separately or in conjunction with each other to achieve the regulatory norms. This also follows the route of mercury recovery/recycling by chemical means or by heating mercury-laden resin in a retort followed by distillation.

The atmospheric emissions of mercury are from electrolytic cell room and hydrogen venting from hydrogen handling tank. The World Health Organization (WHO) has recommended the concentration of mercury in cell room not to exceed from 0.05 mg per m³ of air. The gas emissions from these sources may be properly collected and cooled following de-mercurisation by activated carbon or ion exchange resin. Mercury vapour is much higher than air and swiftly elutriates, and is carried away long distance by wind and descends on the earth contaminating water, air, land and vegetation and finally gets into mammal. Such heavy metals with high mobility and vapor pressure will try to escape into the environment despite precautions. Mercury vapor in cell room be monitored regularly for remedial action to control Hg loss by adopting the BAT which is practically achievable.

Brine mud demercurisation – during the brine purification addition of sodium hypochlorite (NaOCl) can prevent precipitation of mercury in brine and this reduces the level of mercury in brine sludge to a large extend. The sludge is further treated by sodium hydrochloride followed by vacuum drum filtration. The filtrate containing mercury, if required, may pass through ion exchange resin tower after filtration and removal of insoluble. The treated water can either be taken to brine system or discharge along with the segregated effluent after meeting the regulatory requirement. The use of poor quality salt results in large quantities of brine-mud which poses disposal problem and also groundwater contamination. The brine sludge from chlor-alkali industry is identified as hazardous waste as per HW (M&H) Rules notified by the government. The disposal of brine-mud should be in accordance with the rules and guidelines published by

the government in order to protect the groundwater and air around the disposal/dump site. In case the brine-mud leachate quality contains mercury concentration as per the proposed standards, the sludge is required to be pre-treated before disposal in order to avoid leachate generation and groundwater contamination. The chlor-alkali industry should use good quality of salt to minimize brine sludge generation and also loss of mercury through solid route which is huge (maximum) when compared to other sources. Many industries are using ISI grade salt to reduce loss of salt, as well as mercury.

Caustic soda generated from MRCP contains mercury. It should first be cooled and then filtered through a vertical leaves pre-coat filter (charcoal for removal and treatment of mercury from the product. Hydrogen gas from MRCP should also be cooled to lower the level of mercury content and then be passed through a treatment system comprising activated carbon and ion-exchange resin column.

REFERENCES

Documents

- **Ministry of Environment and Forest, GoI** - “Environment Impact Assessment Notification” S.O.1533 dated 14th September 2006.
- **Ministry of Environment and Forest, GoI** – “Environment Impact Assessment Notification 2006 – Amendment S.O. 195 (E)” consideration dated 1st December, 2009.
- **Ministry of Environment and Forest, GoI** – Charter on Corporate Responsibility for Environment Protection Action Points for 17 Categories of Industries, CPCB, March 2003.
- **Larry W. Canter**, “Environmental Impact Assessment”, Second Edition, McGraw Hill, University of Oklahoma, 1997.
- **International Association for Impact Assessment** – “Principles of Environmental Impact Assessment Best Practice”, Institute of Environmental Assessment, UK.
- **Integrated Pollution Prevention and Control (IPPC)** – Reference Document on Best available Techniques in the Chlor-Alkali Manufacturing Industry, European Commission December 2001.
- **European Environmental Agency** - “Continuity, Credibility and Comparability, Key challenges for corporate environmental performance measurement and communication”, The International Institute for Industrial Environmental Economics, Lund University, February, 1998.
- **Energy Conservation in Chlor-Alkali & Chemicals Industry through Instrumentation** – United Phosphorus Limited Consultant (EC & Technical), Gujarat Alkalied and Chemicals Ltd., Vadodara, India.
- **Office of Industrial Technologies Energy Efficiency and Renewable Energy** – U.S. Department of Energy, Washingto, DC 20585, ORNL 2002-03182/jcn.
- **Chlor-Alkali** – Asia Sustainable and Alternative Energy Program (ASTAE), U.S. Department of Energy.
- **REIA study for Chlor-Alkali plant of Meghmani Organics Limited** – San Envirotech Pvt. Ltd, Ahmedabad.
- **Mercury, membrane or diaphragm Introduction** – University of Glasgow
- **The Chlor-Alkali Industry and Mercury Cell Technology** - Arthur E. Dungan Vice President - Safety, Health and Environment The Chlorine Institute, Inc .May 30,2002.
- **Environmental Guidelines for Chlor-Alkali Industry** - Multilateral Investment Guarantee Agency.
- **Industrial IT for the Chlor-alkali Industry** – ABB Consultants



- *History of the Chlor-Alkali Industry* - Hand book of chlor - alkali technology

Websites

- <http://envfor.nic.in/divisions/iass/eia.htm>
- <http://eetd.lbl.gov/ea/ies/ieua/Pubs.html>
- <http://industrial-energy.lbl.gov/node/130>
- <http://www.cpcb.nic.in/>
- <http://www.epa.gov/>
- <http://www.iaia.org>
- http://aida.ineris.fr/bref/brefca/bref_gb_gen.htm
- http://findarticles.com/p/articles/mi_6960/is_2_1/ai_n28319187/
- http://multinationalmonitor.org/hyper/issues/1995/01/mm0195_11.html



IL&FS Ecosmart Limited
Flat # 408, Saptagiri Towers
Begumpet
Hyderabad – 500 016
Ph: + 91 40 40163016
Fax: + 91 40 40032220

For any queries or technical inputs kindly mail:

sateesh.babu@ifsecosmart.com

suman.thomas@ifsecosmart.com